

Complete Machining Solutions

GROOVE-TURN



TABLE OF CONTENTS

GROOVE-TURN	239
Selection Guide	242
External Tools and Inserts	
HELI-GRIP Tools and Inserts	249
TOP-GRIP Tools and Inserts	256
CUT-GRIP Tools and Inserts	258
Tools, Adapters and Blades (short pocket)	258
Tools, Adapters and Blades (long pocket)	268
Utility Inserts	271
Precision Ground Inserts	275
Inserts for Specific Applications and Materials	
Cast Iron	282
Hardened Steel	283
High Temperature Alloys	284
Aluminum	284
Next to Shoulder	286
Undercutting	287
Pulley V Grooves	288
T/L Grooves	289
GDMW Tools and Inserts	293
Multi-Corner Grooving Tools and Inserts	
PENTACUT (5 cutting edges)	295
GTGA (3 cutting edges)	311
Tools and Inserts for Heavy Duty Grooving and Turning	313

Internal Tools and Inserts	
CUT-GRIP Boring Bars Dmin 12.5 mm (GEPI inserts).....	323
CUT-GRIP Boring Bars Dmin 20 mm (GIPI/GIFI/GINI inserts).....	329
TOP-GRIP Boring Bars Dmin 20.5 mm	338
HELI-GRIP Boring Bars Dmin 26 mm	339
CUT-GRIP Boring Bars Dmin 64 mm (GDMY/F/N 8 mm inserts)	339
CUT-GRIP Blades Dmin 70 mm	339

Tools for Swiss-Type and Small Lathe Machines

External Tools and Inserts	
SWISSCUT.....	347
CUT-GRIP.....	356

Internal Boring Bars and Inserts	
PICCO (Dmin 0.6 mm).....	359
MINICHAM (Dmin 4 mm).....	372
MINCUT (Dmin 8 mm)	374
CHAMGROOVE (Dmin 8 mm)	375

Form Tools	343
------------------	-----

Broaching Tools.....	401
----------------------	-----

Tools for Machining Aluminum Wheels.....	405
--	-----

USER GUIDE.....	380
-----------------	-----

PARTING	417
----------------------	------------

FACE GROOVING AND TURNING	533
--	------------

TOOL BLOCKS	585
--------------------------	------------

EXCHANGEABLE HEAD HOLDERS	589
--	------------

Information to Select the Correct Insert

ISCAR has an extensive variety of Groove-Turn products. In many cases, you can perform your operation by using several different products. In order to make the optimal selection, these basic parameters need to be defined:

- Insert width [CW]
- Necessary tolerance on the insert
- Maximum depth of grooving [CDX]
- Application requirement grooving and turning, or only grooving (E-Type or not)

According to these parameters:

- Select the most suitable product according to the tables on pages 243-244
- Select the most suitable chipformer according to the information on pages 245-247

Utility Inserts

Pressed to Size Inserts

Width	± 0.05
Repeatability	± 0.10

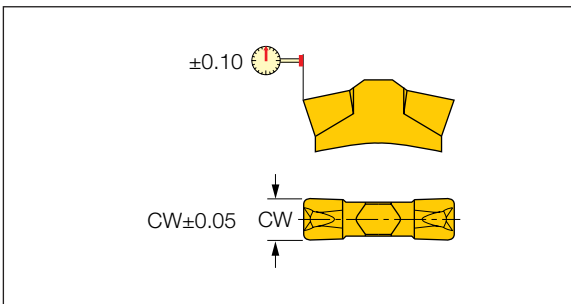

If you don't need the tight tolerance, save money and select a utility insert (less expensive).

Precision Grooving Inserts

Peripheral Ground Inserts

Width	± 0.02
Repeatability	± 0.025

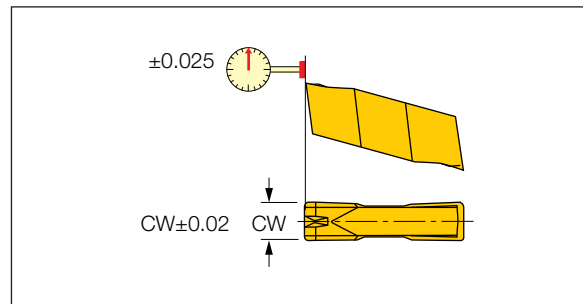

What is an E-type Groove-Turn Insert?

E-type inserts are precision ground grooving inserts with **turning** capability.

These inserts include the letter **E** in their description. (example: **GIP 3.00E-0.4**). This is to distinguish them from precision ground inserts which are not suitable for turning operations and don't include an **E** in their description. (example: **GIP 3.00-0.2**)

- E-type inserts usually have a larger corner radius
- E-type inserts have a larger honing size

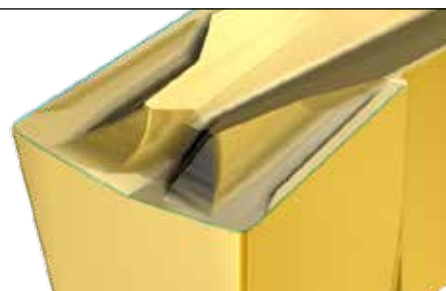

Precision Grooving Insert



E-Type Groove-Turn



External Groove-Turn Insert Type

	Insert	Properties				CW range	CDX	Page	
		Precision Ground	Utility	Number of Cutting Edges	Option for Turning				
PENTACUT	 PENTACUT Size 17	✓		5		0.25-3.18	4	295-297	
	 PENTACUT Size 24	✓		5		0.5-4.23	1-6.5	303-309	
	 PENTACUT Size 34	✓		5		1.5-4.0	5-10	310-311	
TOP-GRIP	 HELI-GRIP		✓	2	✓	3-6.35	No depth limit	254-255	
	 TOP-GRIP		✓	2	✓	3-6.35	10.5-18.6	257-258	
CUT-GRIP	 Short Pocket		✓	1	✓	3-12	No depth limit	271-275	
	 Short Pocket	✓		2	✓*	0.5-11.0	13**	276-287	
	 Long Pocket	Long Pocket		✓	2	✓*	8.0	27	271-275
		Long Pocket	✓		2	✓	8.0-11.0	27	276-287
HEAVY DUTY	 SUMO-GRIP		✓	1	✓	6-14	No depth limit	319	
	 TIGER		✓	1		10-20	No depth limit	315, 320	

* Not on all the products

** On most items

Internal Groove-Turn Insert Type

		Tool	Insert	Utility	Precision	DMIN	CDX	CW	Page
PICCO-CUT		PICCO/ MG PCO	PICCO		✓	2.0-7.0	0.4-2.5	0.5-2	362-372
CHAMGROOVE		MG/MGCH	GIQR 8		✓	8.0	0.7-1.5	0.5-4	376, 378-379
		MG/MGCH	GIQR 11		✓	11.0	1.5-2.3	0.75-5	377
		MGCH	GIQR 11-15		✓	15.0	6.3	1-3	378
CUTGRIP		GEHIR/L	GEPI/ GEMI	✓	✓	12.5-16	2.4-3.0	1-3.18	326-329
		GHIR/L	GIFI/GIPI/ GINI/GIMIY	✓	✓	20-49	2.5-8.0	1.53-6.35	322-327
TOPGRIP		TGIR/L	TGMF	✓		20.5-57	5.5-17.5	3-6.35	257-258
HELIGRIP		HELIIR/L	GRIP	✓		26-53	5-12	3-6.35	254-255
CUTGRIP		GHIR/L 40-8	GDMF/ GDMY/ GDMN...	✓	✓	65	15-20	8-11	271-277
		GHIC/CGHN	GIP/GIF/ GIMN/GIMF/ GIA...	✓	✓	70-250	10-26	2.8-6.35	271-287

Chipbreaker Selection

T-Type

- Optimal performance in wide range of materials and cutting conditions
- High efficiency in full grooving, partial grooving and turning applications
- Utility inserts only
- Width range
External: 2.39 - 6.35 mm



General Use

P-Type

- Very “open” geometry
- Medium to high feed in turning and grooving
- Large variety of standard sizes
- Precision ground inserts only
- Width range
External: 2.39 - 6.35 mm
Internal: 2.39 - 6.35 mm



F-Type

- First choice in grooving
- Low to medium feeds in grooving and turning
- Both precision ground and utility inserts
- Width range
External: 3.0 - 10 mm
Internal: 3 - 6 mm



G-Type

- Efficient chipbreaker for narrow width grooves
- Width range: 1 - 2.3 mm
- No option for turning

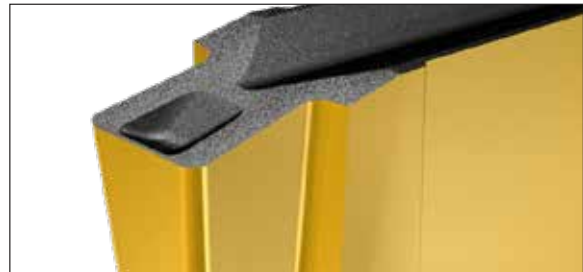

Y-Type

- General use in grooving and turning
- Positive top rake reduces cutting forces
- Excellent for long shafts
- Eliminates vibrations
- Both precision ground and utility inserts
- Width range
External: 8 - 20 mm



HG-Y-Type

- General use in grooving and turning
- Efficient for a wide range of materials and cutting conditions
- Utility inserts only
- Width range
External: 3 - 6.35 mm
Internal: 3 - 6.35 mm



Chipbreaker Selection

Problematic and Specific Materials

N-Type

- First choice in grooving of problematic, soft & gummy materials
- Very low to medium feeds (from 0.05 mm/rev)
- Both precision ground and utility inserts
- Option for turning
- Width range
External: 3 - 8 mm
Internal: 2 - 5 mm



M-Type

- Unique chipbreaker with splitter
Chips are split into 3 segments
- Efficient for problematic, soft & gummy materials
- Option for light turning
- Width - 8 mm



A-Type

- First choice for machining cast Iron
- Peripheral 15° T-land on a flat top
- Exerts high cutting forces, therefore suitable for stable conditions
- Precision ground inserts only
- Width range
External: 3 - 8 mm

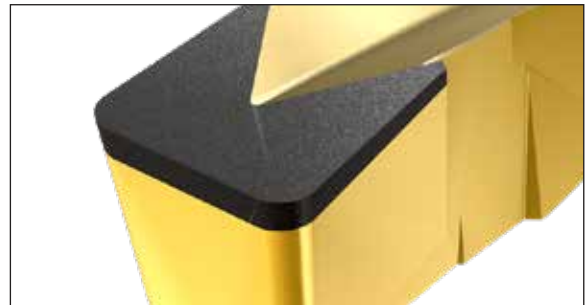

PA-Type

- First choice for machining aluminum
- High positive rake
- Peripheral ground and polished top rake with a very sharp edge
- Suitable also for finish operations on titanium and heat resistant alloys
- Width range
External: 3 - 8 mm



CW-Type

- Unique chipformer for heavy-duty grooving
- Very wide chipbreaking range on carbon and alloy steel
- Width range 14, 17 and 20 mm



Chipbreaker Selection

Profiling (Full radius)

Y-Type

- First choice in profiling
- Positive top rake reduces cutting forces
- Excellent for long shafts
- Eliminates vibrations
- Both precision ground and utility inserts
- Width range
External: 3 - 12 mm
Internal: 2 - 3 mm



YF-Type

- First choice for profiling ductile materials
- Utility inserts only
- Width range
External: 3 - 8 mm



PA-Type

- First choice for profiling aluminum
- High positive rake
- Peripheral ground and polished top rake with a very sharp edge
- Suitable also for finish operations on titanium and heat resistant alloys
- Width range
External: 3 - 8 mm



YZ-Type

- First choice for profiling ductile aluminum
- Peripheral ground and polished top rake with a very sharp edge
- Width range
External: 3 - 8 mm



H-Type

- Unique chipbreaker for heavy-duty profiling
- Negative T-land for extra edge toughness
- Suitable for heavy interrupted cuts and cast iron machining
- Width - 12 mm



Chipbreaker Width Range







External

Insert Width										
12				20						
11										
10										
9										
8										
7										
6		6.35				6.35				
5										
4										
3			3.48							
2	2.3	2.39								
1										
	G	P	F	Y	N	HG-Y	M	A	PA	T

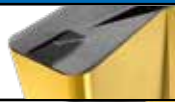
Internal

Insert Width				
7				
6	6.35			6.35
5				
4				
3				
2	2.39			
1				
	P	F	N	HG-Y

Suitable Chipbreaker and Required Feed Range for Workpiece Material



	Alloy Steel	Austenitic Stainless	High Temp. Alloys	Nonferrous Materials	Cast Iron
High	 P	P	P		
	 HG-Y	HG-Y	Y	PA*	A*
	 Y	Y	F	P	P
Feed	 F	F	PA (finish only)		HG
	 T*	T*	T	T	
Low	 N				F

* First Choice

C#-HELIR/L

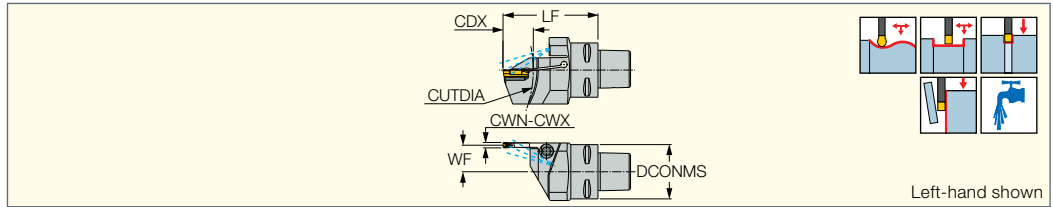
External Tools for Turning,
Grooving and Parting with
CAMFIX Exchangeable Shanks



Designation	DCONMS	CWN ⁽¹⁾	CWX ⁽²⁾	WF	LF	CUTDIA ⁽³⁾	Insert			
C4 HELIR/L 3T20	40.00	3.00	3.18	20.00	65.00	40.0	GRIP 3, HGN 3	SR M6X16 DIN912	HW 5.0	EZ 104
C4 HELIR/L 4T25	40.00	4.00	4.76	19.60	70.00	50.0	GRIP 4, DGN 4	SR M6X16 DIN912	HW 5.0	EZ 104
C5 HELIR/L 3T20	50.00	3.00	3.18	25.30	65.00	40.0	GRIP 3, HGN 3	SR M6X16 DIN912	HW 5.0	EZ 104
C5 HELIR/L 4T25	50.00	4.00	4.76	24.90	70.00	50.0	GRIP 4, DGN 4	SR M6X16 DIN912	HW 5.0	EZ 104
C5 HELIR/L 5T25	50.00	5.00	5.00	24.40	70.00	50.0	GRIP 5, DGN 5	SR M6X16 DIN912	HW 5.0	EZ 104
C6 HELIR/L 3T20	63.00	3.00	3.18	31.80	65.00	40.0	GRIP 3, HGN 3	SR M6X16 DIN912	HW 5.0	EZ 104
C6 HELIR/L 4T25	63.00	4.00	4.76	31.40	70.00	50.0	GRIP 4, DGN 4	SR M6X16 DIN912	HW 5.0	EZ 104
C6 HELIR/L 5T25	63.00	5.00	5.00	30.90	70.00	50.0	GRIP 5, DGN 5	SR M6X16 DIN912	HW 5.0	EZ 104
C6 HELIR/L 6T30	63.00	6.00	6.35	30.40	85.00	60.0	GRIP 6, DGN 6	SR M6X16 DIN912	HW 5.0	EZ 104

• The depth of cut (CDX) for grooving is limited by the part diameter CUTDIA, for grooving depth capacity, see table below

⁽¹⁾ Minimum cutting width

⁽²⁾ Maximum cutting width

⁽³⁾ Maximum parting diameter

For inserts, see pages: GRIP (254) • GRIP (full radius) (255) • DGN/DGNC/DGNM-C (438) • HGN-C (445) • DGR/L-C DGRC/LC-C (439) • DGN/DGNM-J/JS/JT (440) • HGN-J (446) • HGR/L-C (445) • HGR/L-J/JS (446) • DGR/L-J/JS (441) • DGN-MF (442) • DGN-UT/UA (443) • DGN-W (439) • HGN-UT (446)

Grooving Depth Capacity

Designation	CUTDIA																													
	∞	∞	∞	∞	1151	384	231	167	131	109	94	83	—	—	—	—	—	—	—	—	—	—	—	—	—	—	—	—	—	
C4 HELIR/L 3T20	∞	∞	∞	∞	∞	∞	∞	∞	∞	∞	∞	∞	1127	376	227	163	128	107	—	—	—	—	—	—	—	—	—	—	—	—
C4 HELIR/L 4T25	∞	∞	∞	∞	∞	∞	∞	∞	∞	∞	∞	∞	1301	434	261	188	148	122	105	—	—	—	—	—	—	—	—	—	—	—
C5 HELIR/L 3T20	∞	∞	∞	∞	∞	∞	∞	∞	∞	∞	∞	∞	1301	434	261	188	148	122	105	—	—	—	—	—	—	—	—	—	—	—
C5 HELIR/L 4T25	∞	∞	∞	∞	∞	∞	∞	∞	∞	∞	∞	∞	1301	434	261	188	148	122	105	—	—	—	—	—	—	—	—	—	—	—
C5 HELIR/L 5T25	∞	∞	∞	∞	∞	∞	∞	∞	∞	∞	∞	∞	1301	434	261	188	148	122	105	—	—	—	—	—	—	—	—	—	—	—
C6 HELIR/L 3T20	∞	787	394	264	199	161	136	118	105	95	87	81	—	—	—	—	—	—	—	—	—	—	—	—	—	—	—	—	—	—
C6 HELIR/L 4T25	∞	∞	∞	∞	∞	∞	∞	1957	653	393	282	221	182	156	137	122	111	102	—	—	—	—	—	—	—	—	—	—	—	—
C6 HELIR/L 5T25	∞	∞	∞	∞	∞	∞	∞	1957	653	393	282	221	182	156	137	122	111	102	—	—	—	—	—	—	—	—	—	—	—	—
C6 HELIR/L 6T30	∞	∞	∞	∞	∞	∞	∞	∞	∞	∞	∞	∞	1879	627	377	271	212	175	150	131	118	107	99	—	—	—	—	—	—	—
CDX	9	10	11	12	13	14	15	16	17	18	19	20	21	22	23	24	25	26	27	28	29	30	—	—	—	—	—	—	—	—



HELIR/L

External Holders for Turning, Grooving and Parting

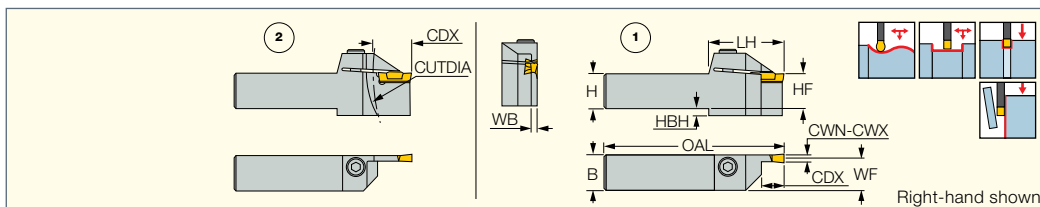

Designation	CDX ⁽²⁾	CWN ⁽³⁾	CWX ⁽⁴⁾	Fig.	CUTDIA ⁽⁵⁾	H	HF	B	WF	OAL	LH	WB	HBH	Insert
HELIR/L 1212-3T12	12.00	3.00	3.18	1.	-	12.0	12.0	12.0	10.80	135.00	30.0	2.40	4.0	GRIP-3..., HG.-3
HELIR/L 1616-3T12	12.00	3.00	3.18	1.	-	16.0	16.0	16.0	14.80	135.00	30.0	2.40	-	GRIP-3..., HG.-3
HELIR/L 2020-3T12	12.00	3.00	3.18	1.	-	20.0	20.0	20.0	18.80	135.00	29.0	2.40	-	GRIP-3..., HG.-3
HELIR/L 2525-3T12	12.00	3.00	3.18	1.	-	25.0	25.0	25.0	23.80	135.00	29.0	2.40	-	GRIP-3..., HG.-3
HELIR/L 1616-4T12	12.00	4.00	4.76	1.	-	16.0	16.0	16.0	14.40	135.00	29.0	3.20	-	GRIP-4..., DG.-4
HELIR/L 2020-4T12	12.00	4.00	4.76	1.	-	20.0	20.0	20.0	18.40	135.00	29.0	3.20	-	GRIP-4..., DG.-4
HELIR/L 2525-4T12	12.00	4.00	4.76	1.	-	25.0	25.0	25.0	23.40	135.00	29.0	3.20	-	GRIP-4..., DG.-4
HELIR/L 2020-5T12	12.00	5.00	5.00	1.	-	20.0	20.0	20.0	17.90	135.00	29.0	4.20	-	GRIP-5..., DG.-5
HELIR/L 2525-5T12	12.00	5.00	5.00	1.	-	25.0	25.0	25.0	22.90	135.00	29.0	4.20	-	GRIP-5..., DG.-5
HELIR/L 2525-6T12	12.00	6.00	6.35	1.	-	25.0	25.0	25.0	22.40	135.00	29.0	5.20	-	GRIP-6..., DG.-6
HELIR/L 1616-3T20 ⁽¹⁾	-	3.00	3.18	2.	40.0	16.0	16.0	16.0	14.80	140.00	36.4	2.40	-	GRIP-3..., HG.-3
HELIR/L 2020-3T20 ⁽¹⁾	-	3.00	3.18	2.	40.0	20.0	20.0	20.0	18.80	140.00	36.4	2.40	-	GRIP-3..., HG.-3
HELIR/L 2525-3T20 ⁽¹⁾	-	3.00	3.18	2.	40.0	25.0	25.0	25.0	23.80	140.00	36.4	2.40	-	GRIP-3..., HG.-3
HELIR/L 3232-3T20 ⁽¹⁾	-	3.00	3.18	2.	40.0	32.0	32.0	32.0	30.80	150.00	36.4	2.40	-	GRIP-3..., HG.-3
HELIR/L 1616-4T20	-	4.00	4.76	2.	40.0	16.0	16.0	16.0	14.40	140.00	38.0	3.20	4.0	GRIP-4..., DG.-4
HELIR/L 2020-4T25	-	4.00	4.76	2.	50.0	20.0	20.0	20.0	18.40	140.00	42.0	3.20	-	GRIP-4..., DG.-4
HELIR/L 2525-4T25	-	4.00	4.76	2.	50.0	25.0	25.0	25.0	23.40	140.00	42.0	3.20	-	GRIP-4..., DG.-4
HELIR/L 3232-4T25	-	4.00	4.76	2.	50.0	32.0	32.0	32.0	30.40	150.00	43.0	3.20	-	GRIP-4..., DG.-4
HELIR/L 2020-5T25	-	5.00	5.00	2.	50.0	20.0	20.0	20.0	17.90	140.00	42.0	4.20	-	GRIP-5..., DG.-5
HELIR/L 2525-5T25	-	5.00	5.00	2.	50.0	25.0	25.0	25.0	22.90	140.00	42.0	4.20	-	GRIP-5..., DG.-5
HELIR/L 3232-5T25	-	5.00	5.00	2.	50.0	32.0	32.0	32.0	29.90	150.00	43.0	4.20	-	GRIP-5..., DG.-5
HELIR/L 2525-6T30	-	6.00	6.35	2.	60.0	25.0	25.0	25.0	22.40	140.00	51.4	5.20	-	GRIP-6..., DG.-6
HELIR/L 3232-6T30	-	6.00	6.35	2.	60.0	32.0	32.0	32.0	29.40	150.00	51.4	5.20	-	GRIP-6..., DG.-6

- For tool type as shown in Fig.2, CDX for grooving is limited by the part diameter CUTDIA, for grooving depth capacity, see table below
- For user guide, see pages 380-395
- ⁽¹⁾ DGN inserts are not suitable for this tool
- ⁽²⁾ Does not depend on the workpiece diameter
- ⁽³⁾ Minimum cutting width
- ⁽⁴⁾ Maximum cutting width
- ⁽⁵⁾ Maximum parting diameter

Spare Parts

Designation		
HELIR/L 1212-3T12	SR M5X16 DIN912	HW 4.0
HELIR/L 1616-3T12	SR M5X16 DIN912	HW 4.0
HELIR/L 2020-3T12	SR M5X16 DIN912	HW 4.0
HELIR/L 2525-3T12	SR M5X16 DIN912	HW 4.0
HELIR/L 1616-4T12	SR M5X16 DIN912	HW 4.0
HELIR/L 2020-4T12	SR M5X16 DIN912	HW 4.0
HELIR/L 2525-4T12	SR M5X16 DIN912	HW 4.0
HELIR/L 2020-5T12	SR M6X16 DIN912	HW 5.0
HELIR/L 2525-5T12	SR M6X16 DIN912	HW 5.0
HELIR/L 2525-6T12	SR M6X16 DIN912	HW 5.0
HELIR/L 1616-3T20	SR M6X20 DIN912	HW 5.0
HELIR 2020-3T20	SR M6X20 DIN912	HW 5.0
HELIR 2020-3T20	SR M6X16 DIN912	HW 5.0
HELIR/L 2525-3T20	SR M6X20 DIN912	HW 5.0
HELIR/L 3232-3T20	SR M6X20 DIN912	HW 5.0
HELIR/L 1616-4T20	SR M6X20 DIN912	HW 5.0
HELIR/L 2020-4T25	SR M6X20 DIN912	HW 5.0
HELIR/L 2525-4T25	SR M6X20 DIN912	HW 5.0
HELIR/L 3232-4T25	SR M6X20 DIN912	HW 5.0
HELIR 2020-5T25	SR M6X20 DIN912	HW 5.0
HELIR 2020-5T25	SR M6X16 DIN912	HW 5.0
HELIR/L 2525-5T25	SR M6X20 DIN912	HW 5.0
HELIR/L 3232-5T25	SR M6X20 DIN912	HW 5.0
HELIR/L 2525-6T30	SR M6X20 DIN912	HW 5.0
HELIR/L 3232-6T30	SR M6X20 DIN912	HW 5.0

Depth Capacity

Designation	CUTDIA														
HELIR/L 1616-3T20	∞	∞	∞	∞	∞	∞	194	80	-	-	-	-	-	-	
HELIR/L 2020-3T20	∞	∞	∞	∞	∞	299	123	80	-	-	-	-	-	-	
HELIR/L 2525-3T20	∞	∞	∞	815	229	136	99	79	-	-	-	-	-	-	
HELIR/L 3232-3T20	∞	604	261	169	127	103	89	79	-	-	-	-	-	-	
HELIR/L 1616-4T20	∞	∞	∞	∞	∞	505	132	78	-	-	-	-	-	-	
HELIR/L 2020-4T20	∞	∞	∞	∞	∞	∞	∞	∞	∞	∞	185	98	-	-	
HELIR/L 2525-4T20	∞	∞	∞	∞	∞	∞	∞	368	233	136	98	-	-	-	
HELIR/L 3232-4T20	∞	∞	∞	∞	∞	626	270	175	149	-	98	-	-	-	
HELIR/L 2020-5T20	∞	∞	∞	∞	∞	∞	∞	∞	∞	∞	182	98	-	-	
HELIR/L 2525-5T20	∞	∞	∞	∞	∞	∞	∞	368	233	136	98	-	-	-	
HELIR/L 3232-5T20	∞	∞	∞	∞	∞	626	270	175	149	-	98	-	-	-	
HELIR/L 2525-6T20	∞	∞	∞	∞	∞	∞	∞	∞	∞	∞	354	135	98	-	
HELIR/L 3232-6T20	∞	∞	∞	∞	∞	∞	∞	∞	∞	∞	1718	345	194	121	98
CDX	6.5	8.0	10.0	12.0	14.0	16.0	18.0	20.0	21.0	23.0	25.0	28.0	30.0		

HGPAD

Adapters for Turning,
Grooving and Parting

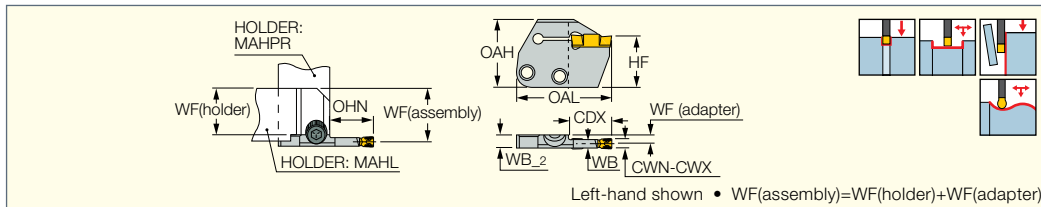

Designation	CWN ⁽¹⁾	CWX ⁽²⁾	CDX ⁽³⁾	OHN ⁽⁴⁾	WF ⁽⁵⁾	WB	WB_2	OAL	OAH	HF	Insert
HGPAD 3R/L-T12	3.00	3.20	12.00	15.2	4.80	2.50	6.0	39.70	32.0	24.0	GRIP 3, HGN 3
HGPAD 3R/L-T20	3.00	3.20	20.00	21.2	4.80	2.50	6.0	45.70	32.0	24.0	GRIP 3, HGN 3
HGPAD 4L-T12	4.00	4.76	12.00	18.7	4.40	3.30	6.0	43.20	32.0	24.0	GRIP 4, DGN 4
HGPAD 4L-T20	4.00	4.76	20.00	21.2	4.40	3.30	6.0	45.70	32.0	24.0	GRIP 4, DGN 4
HGPAD 5L-T12	5.00	5.00	12.00	18.7	3.90	4.20	6.0	43.20	32.0	24.0	GRIP 5, DGN 5
HGPAD 5L-T20	5.00	5.00	20.00	21.2	3.90	4.20	6.0	45.70	32.0	24.0	GRIP 5, DGN 5
HGPAD 6L-T12	6.00	6.35	12.00	18.7	3.40	5.20	6.0	43.20	32.0	24.0	GRIP 6, DGN 6
HGPAD 6R/L-T22	6.00	6.35	22.00	23.2	3.40	5.20	6.0	47.70	32.0	24.0	GRIP 6, DGN 6

• DO-GRIP DGN, HGN inserts can be used for grooving only • For user guide, see pages 380-395

- (1) Minimum cutting width
- (2) Maximum cutting width
- (3) Cutting depth maximum
- (4) Minimum overhang
- (5) WF(adapter)

HGPAD-JHP

Adapters with High Pressure
Coolant Channels Carrying
HELI-GRIP Inserts

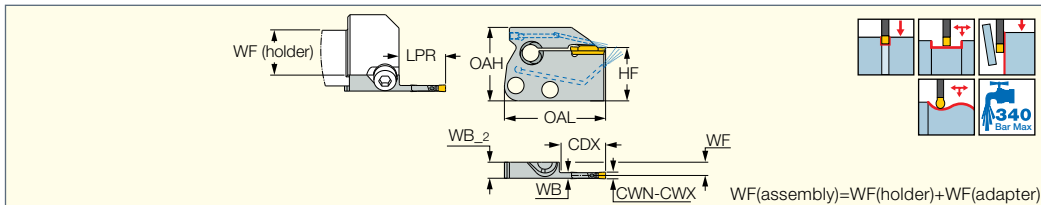

Designation	CWN ⁽¹⁾	CWX ⁽²⁾	CDX	LPR	WF	WB	WB_2	OAL	OAH	HF
HGPAD 3R/L-T20-JHP	3.00	3.20	20.00	21.0	5.95	2.50	7.2	45.70	33.0	24.0
HGPAD 4L-T20-JHP	4.00	4.76	20.00	21.0	5.55	3.30	7.2	45.70	33.0	24.0
HGPAD 5L-T20-JHP	5.00	5.00	20.00	21.0	5.10	4.20	7.2	45.70	33.0	24.0
HGPAD 6R/L-T22-JHP	6.00	6.35	22.00	23.0	4.60	5.20	7.2	47.70	33.0	24.0

• For user guide and accessories, see pages 380-400

- (1) Minimum cutting width
- (2) Maximum cutting width

For inserts, see pages: DGN-MF (442) • GRIP (254) • GRIP (full radius) (255) • DGN/DGNC/DGNM-C (438) • HGN-C (445) • DGN/DGNM-J/JS/JT (440) • HGN-J (446) • HGR/L-C (445) • HGR/L-J/JS (446) • DGN-UT/UA (443) • HGN-UT (446) • DGN-W (439)

For holders, see pages: C#-MAHD-JHP (593) • C#-MAHPD-JHP (593) • MAHR/L-JHP-MC (263) • MAHPR/L-JHP (264) • MAHR/L-JHP (263)

Flow Rate vs. Pressure

Designation	70 Bar	100 Bar	140 Bar
	Flow Rate (liters/min)	Flow Rate (liters/min)	Flow Rate (liters/min)
HGPAD 3R/L-T20-JHP	5-7	6-8	7-9
HGPAD 4R/L-T20-JHP	9-11	10-12	11-13
HGPAD 5R/L-T20-JHP	11-13	12-14	13-15
HGPAD 6R/L-T22-JHP	16-18	16-18	19-21

HGFH

Parting and Grooving Blades
for 3 mm GRIP Inserts

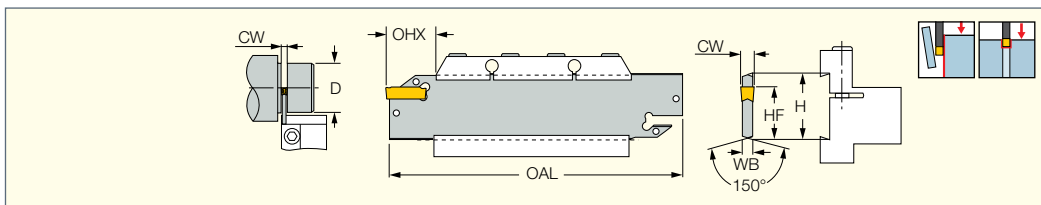

Designation	H	CW	WB	OAL	HF	OHX ⁽¹⁾	CUTDIA	Insert
HGFH 26-3	26.0	3.00	2.40	110.00	21.4	37.5	75.0	EDG 23B*
HGFH 32-3	32.0	3.00	2.40	150.00	24.8	50.0	100.0	EDG 23B*

(1) Maximum overhang

* Optional, should be ordered separately

For inserts, see pages: GRIP (254) • GRIP (full radius) (255) • HGN-C (445) • HGR/L-C (445) • HGN-J (446) • HGN-UT (446) • HGR/L-J/JS (446)

For holders, see pages: C#-TBK-R/L (591) • HSK A-WH-TBK-R/L (598) • SGTBF (587) • SGTBR/L (587) • SGTBU/SGTBN (586) • UBHCR/L (587)

DGFH

Parting and Grooving Blades with and without Coolant Channels Carrying DO-GRIP and HELI-GRIP Inserts

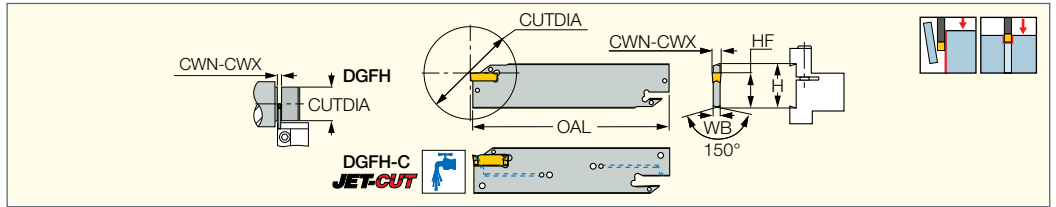

Designation	H	CWN ⁽⁴⁾	CWX ⁽⁵⁾	WB	OAL	HF	CUTDIA	Insert
DGFH 26-1.4	26.0	1.40	1.40	2.50 ⁽⁷⁾	110.00	21.4	26.0	DG. 14..
DGFH 26-2 ⁽¹⁾	26.0	1.90 ⁽⁶⁾	2.50	1.60	110.00	21.4	39.0 ⁽⁸⁾	DG. 1.../DG. 2...
DGFH 26-3 ⁽¹⁾	26.0	3.00 ⁽⁶⁾	3.18	2.40	110.00	21.4	39.0 ⁽⁸⁾	DG. 1.../DG. 3...
DGFH 26C-3 ⁽²⁾	26.0	3.00	3.18	2.40	110.00	21.4	39.0 ⁽⁸⁾	DGNC/DGRC/DGLC 3...
DGFH 26-4	26.0	4.00	4.00	3.20	110.00	21.4	80.0	DG. 4.../GRIP 4...
DGFH 32-1.4	32.0	1.40	1.40	2.50 ⁽⁷⁾	150.00	24.8	26.0	DG. 14
DGFH 32-2 ⁽¹⁾	32.0	1.90 ⁽⁶⁾	2.50	1.80	150.00	24.8	39.0 ⁽⁸⁾	DG. 1.../DG. 2...
DGFH 32-3 ⁽¹⁾	32.0	3.00 ⁽⁶⁾	3.18	2.40	150.00	24.8	39.0 ⁽⁸⁾	DG. 1.../DG. 3...
DGFH 32C-3 ⁽²⁾	32.0	3.00	3.18	2.40	150.00	24.8	39.0 ⁽⁸⁾	DGNC/DGRC/DGLC 3...
DGFH 32-4	32.0	4.00	4.00	3.20	150.00	24.8	100.0	DG. 4.../GRIP 4...
DGFH 32C-4 ⁽³⁾	32.0	4.00	4.00	3.20	150.00	24.8	69.0	DGNC/DGRC/DGLC 4...
DGFH 32-5	32.0	5.00	5.00	4.00	150.00	24.8	120.0	DG. 5.../GRIP 5...
DGFH 32-6	32.0	6.00	6.35	5.20	150.00	24.8	120.0	DG. 6.../GRIP 6...
DGFH 45-3	45.0	3.00 ⁽⁶⁾	3.18	2.40	225.00	38.0	160.0	DG. 1.../DG. 3...
DGFH 45-4	45.0	4.00	4.10	3.20	225.00	38.0	160.0	DG. 4.../GRIP 4...
DGFH 45-5	45.0	4.80	5.00	4.00	225.00	38.0	160.0	DG. 5.../GRIP 5...
DGFH 45-6	45.0	6.00	6.40	5.20	225.00	38.0	160.0	DG. 6.../GRIP 6...

• DG..1.0 insert can be mounted into pocket sizes 2 and 3, in which case the pocket width has to be modified • For user guide, see pages 380-395

⁽¹⁾ For CUTDIA 50 mm, use single-ended insert (should be modified by the user)

⁽²⁾ Blades with frontal coolant holes (JET-CUT) • For CUTDIA 50 mm, use single-ended insert (should be modified by the user)

⁽³⁾ These blades are suitable for turning, using GRIP 4 inserts • Blades with frontal coolant holes (JET-CUT)

⁽⁴⁾ Minimum cutting width

⁽⁵⁾ Maximum cutting width

⁽⁶⁾ For DG. 1... insert, modify holder

⁽⁷⁾ Thickness at the D.O.C. area is 1.0 mm

⁽⁸⁾ Maximum diameter with double-sided inserts.

For inserts, see pages: DGN-LF/LFT (441) • DGN-MF (442) • DGN/DGNC/DGNM-C (438) • DGR/L-C DGRC/LC-C (439) • DGN/DGNM-J/JS/JT (440) • DGR/L-J/JS (441) • DGN-P (444) • DGN-UT/UA (443) • DGN-W (439) • DGN-WP (444) • DGN-Z (442) • DGR-P (444) • DGR-WP (445) • DGR-Z/ZS (443) • GRIP (254) • GRIP (full radius) (255)

For holders, see pages: C#-TBK-R/L (591) • HSK A-WH-TBK-R/L (598) • SGTBF (587) • SGTBK (587) • SGTBR/L (587) • SGTBU/SGTBN (586) • UBHCR/L (587)

Spare Parts

Designation						
DGFH 26-1.4	EDG 23B*					
DGFH 26-2	EDG 23A*					
DGFH 26-3	EDG 23A*					
DGFH 26C-3	EDG 23A*	SGC 340	SGCU 341*	CGF 343*	CF 343*	CGM 343*
DGFH 26-4	EDG 23A*					
DGFH 32-1.4	EDG 23B*					
DGFH 32-2	EDG 33A*					
DGFH 32-3	EDG 33A*					
DGFH 32C-3	EDG 33A*	SGC 340	SGCU 341*	CGF 343*	CF 343*	CGM 343*
DGFH 32-4	EDG 33A*					
DGFH 32C-4	EDG 33A*	SGC 340	SGCU 341*	CGF 343*	CF 343*	CGM 343*
DGFH 32-5	EDG 33A*					
DGFH 32-6	EDG 33A*					
DGFH 45-3	EDG 33A*					
DGFH 45-4	EDG 33A*					
DGFH 45-5	EDG 33A*					
DGFH 45-6	EDG 33A*					

* Optional, should be ordered separately

DGFH-JHP

Parting and Grooving Blades with Channels for Low and High Pressure Coolant Carrying DO-GRIP Inserts

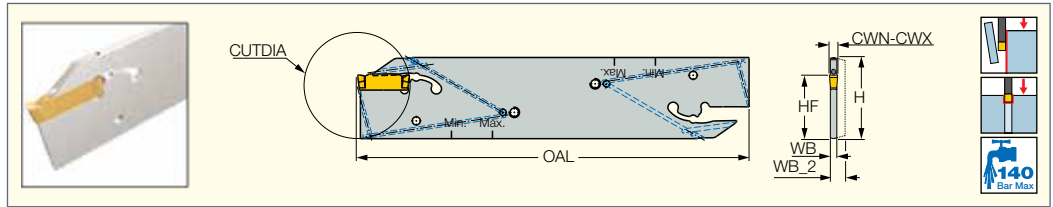

Designation	CWN ⁽²⁾	CWX ⁽³⁾	WB	WB_2	OAL	H	HF	CUTDIA	Insert			
DGFH 32-2-JHP ⁽¹⁾	1.90 ⁽⁴⁾	2.50	1.80	2.5	150.00	32.0	24.8	39.0	DG. 1.../DG. 2...		SGC 340	EDG 33A-JHP*
DGFH 32-3-JHP	3.00 ⁽⁴⁾	3.18	2.50	-	152.00	32.0	24.8	90.0	DG. 1.../DG. 3...	SR M2.0X2.5DIN916	SGC 340	EDG 33A-JHP*
DGFH 32-4-JHP	4.00	4.00	3.20	-	152.00	32.0	24.9	90.0	DG. 4.../GRIP 4...	SR M2.0X2.5DIN916	SGC 340	EDG 33A-JHP*
DGFH 32-5-JHP	5.00	5.00	4.00	-	152.00	32.0	24.9	90.0	DG. 5.../GRIP 5...	SR M2.0X2.5DIN916	SGC 340	EDG 33A-JHP*
DGFH 32-6-JHP ⁽¹⁾	6.00	6.35	5.20	-	160.00	32.0	24.9	90.0	DG. 6.../GRIP 6...		SGC 340	EDG 33A-JHP*

• For user guide and accessories, see pages 380-400

⁽¹⁾ Only an upper channel

⁽²⁾ Minimum cutting width

⁽³⁾ Maximum cutting width

⁽⁴⁾ For DG. 1... insert, modify holder

* Optional, should be ordered separately

For inserts, see pages: DGN-LF/LFT (441) • DGN-MF (442) • DGN-P (444) • DGN-UT/UA (443) • DGN-W (439) • DGN-WP (444) • DGN-Z (442)

• DGN/DGNC/DGNM-C (438) • DGN/DGNM-J/JS/JT (440) • DGR-P (444) • DGR-WP (445) • DGR-Z/ZS (443) • DGR/L-C DGRC/LC-C (439) • DGR/L-J/JS (441)

• GRIP (254) • GRIP (full radius) (255)

For holders, see pages: TGTBU-JHP (454)





GRIP

Utility Double-Ended Inserts for External, Internal and Face Machining

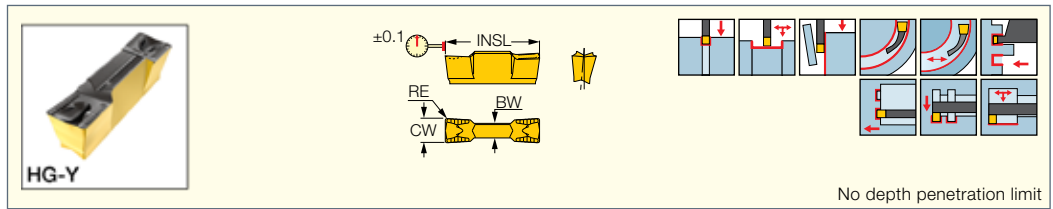

Designation	Dimensions						Tough ← Hard								Recommended Machining Data						
	CW	RE	CWTOL ⁽¹⁾	RETOL ⁽²⁾	INSL	BW	IC830	IC8250	IC08	IC808	IC908	IC418	IC5010	IC806	IC807	IC804	a _p (mm)	f turn (mm/rev)	f groove (mm/rev)	f face-groove (mm/rev)	f face-turn (mm/rev)
GRIP 3002Y	3.00	0.20	0.05	0.050	16.00	2.30	●	●	●	●	●	●	●	●	●	●	0.25-1.80	0.14-0.18	0.07-0.11	0.08-0.20	0.10-0.20
GRIP 3003Y	3.00	0.30	0.05	0.050	16.00	2.30	●	●	●	●	●	●	●	●	●	●	0.40-1.80	0.15-0.19	0.07-0.11	0.08-0.20	0.10-0.20
GRIP 318-040Y	3.18	0.40	0.05	0.050	16.00	2.30	●	●	●	●	●	●	●	●	●	●	0.50-1.90	0.17-0.22	0.07-0.12	0.08-0.20	0.10-0.20
GRIP 4002Y	4.00	0.20	0.05	0.050	19.00	2.80	●	●	●	●	●	●	●	●	●	●	0.25-2.40	0.16-0.21	0.09-0.14	0.10-0.24	0.15-0.30
GRIP 4004Y	4.00	0.40	0.05	0.050	19.00	2.80	●	●	●	●	●	●	●	●	●	●	0.50-2.40	0.18-0.24	0.09-0.15	0.10-0.24	0.15-0.30
GRIP 476-080Y	4.76	0.80	0.05	0.050	19.00	3.10	●	●	●	●	●	●	●	●	●	●	1.00-2.80	0.21-0.33	0.10-0.20	0.10-0.24	0.15-0.30
GRIP 5005Y	5.00	0.50	0.05	0.050	19.00	3.30	●	●	●	●	●	●	●	●	●	●	0.60-3.00	0.20-0.30	0.11-0.20	0.12-0.24	0.15-0.35
GRIP 5008Y	5.00	0.80	0.05	0.050	19.00	3.40	●	●	●	●	●	●	●	●	●	●	1.00-3.00	0.23-0.35	0.11-0.21	0.12-0.24	0.15-0.35
GRIP 6005Y	6.00	0.50	0.05	0.050	19.00	4.20	●	●	●	●	●	●	●	●	●	●	0.60-3.60	0.22-0.36	0.13-0.23	0.12-0.28	0.15-0.40
GRIP 6008Y	6.00	0.80	0.05	0.050	19.00	4.20	●	●	●	●	●	●	●	●	●	●	1.00-3.60	0.24-0.42	0.13-0.25	0.12-0.28	0.15-0.40
GRIP 635-080Y	6.35	0.80	0.05	0.050	19.00	4.20	●	●	●	●	●	●	●	●	●	●	1.00-3.80	0.25-0.44	0.14-0.27	0.12-0.28	0.15-0.40

• For cutting speed recommendations and user guide, see pages 380-395

⁽¹⁾ Cutting width tolerance (+/-)

⁽²⁾ Corner radius tolerance (+/-)

For tools, see pages: C#-HELIR/L (249) • C#-HFIR/L-MC (555) • CR HFIR-M (557) • D/HGAD RE/LE-JHP (437) • DGAD/HGAD (436) • DGFH (252) • DGFH-JHP (253) • DGFS (427) • DGTR/L (433) • HELIR/L (339) • HELIR/L (250) • HFAER/L-4 (551) • HFAER/L-5T, 6T (552) • HFAIR/L-4 (554) • HFAIR/L-DG (555) • HFFR/L-T (550) • HFHR/L-4T (548) • HFHR/L-5T (548) • HFIR/L-MC (556) • HFPAD-3 (549) • HFPAD-4 (549) • HFPAD-5 (550) • HFPAD-6 (550) • HGAER/L-3 (551) • HGAIR/L-3 (554) • HGFR (251) • HGHR/L-3 (547) • HGPAD (251) • HGPAD-JHP (251) • IM-HFIR-MC (556)

The Twisted Insert
for Face Machining

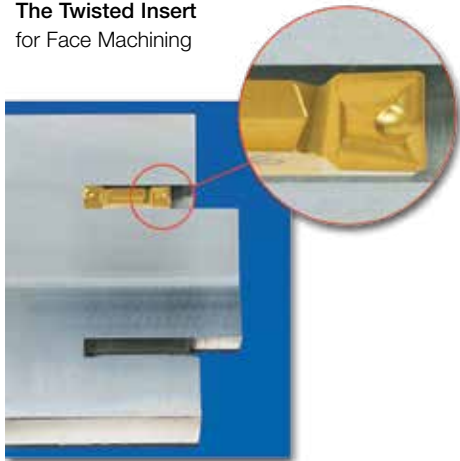

The double-ended, twisted insert body makes it possible to machine deeper than the inserts' length. A unique chipformer for controlled chip flow in axial and radial directions. The rear angle is slanted in relation to the frontal edge so it does not come into contact with the machined groove surface as the tool penetrates deeply into the workpiece.



GRIP (full radius)
Utility Double-Ended Full Radius Inserts for External, Internal and Face Machining

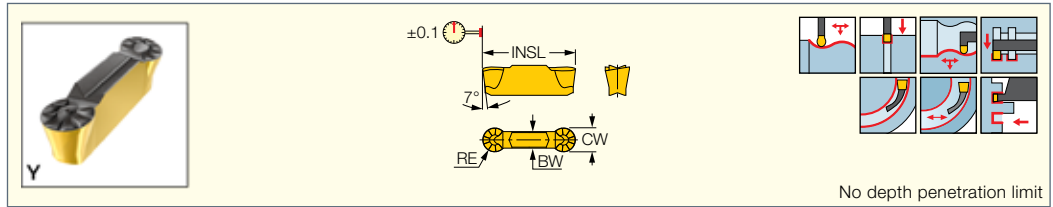

Designation	Dimensions						Tough ← Hard								Recommended Machining Data						
	CW	RE	CWTOL ⁽¹⁾	RETOL ⁽²⁾	INSL	BW	IC830	IC8250	IC08	IC808	IC908	IC418	IC5010	IC806	IC807	IC804	a _p (mm)	f turn (mm/rev)	f groove (mm/rev)	f face-groove (mm/rev)	f face-turn (mm/rev)
GRIP 3015Y	3.00	1.50	0.05	0.050	15.80	2.10	●	●	●	●	●	●	●	●	●	●	0.00-1.50	0.18-0.26	0.07-0.13	0.08-0.20	0.10-0.20
GRIP 318-159Y	3.18	1.59	0.05	0.050	16.00	2.30	●	●	●	●	●	●	●	●	●	●	0.00-1.50	0.19-0.28	0.07-0.13	0.08-0.20	0.10-0.20
GRIP 4020Y	4.00	2.00	0.05	0.050	19.00	2.80	●	●	●	●	●	●	●	●	●	●	0.00-2.00	0.20-0.34	0.09-0.17	0.10-0.24	0.15-0.30
GRIP 476-238Y	4.76	2.38	0.05	0.050	19.00	3.20	●	●	●	●	●	●	●	●	●	●	0.00-2.30	0.21-0.40	0.10-0.20	0.10-0.24	0.15-0.30
GRIP 5025Y	5.00	2.50	0.05	0.050	19.00	3.40	●	●	●	●	●	●	●	●	●	●	0.00-2.50	0.23-0.42	0.11-0.21	0.12-0.24	0.15-0.35
GRIP 6030Y	6.00	3.00	0.05	0.050	19.00	4.20	●	●	●	●	●	●	●	●	●	●	0.00-3.00	0.24-0.50	0.13-0.25	0.12-0.28	0.15-0.40
GRIP 635-318Y	6.35	3.18	0.05	0.050	19.00	4.00	●	●	●	●	●	●	●	●	●	●	0.00-3.10	0.25-0.53	0.14-0.27	0.12-0.28	0.15-0.40

• For cutting speed recommendations and user guide, see pages 380-395

⁽¹⁾ Cutting width tolerance (+/-)

⁽²⁾ Corner radius tolerance (+/-)

For tools, see pages: C#-HELIR/L (249) • C#-HFIR/L-MC (555) • CR HFIR-M (557) • D/HGAD RE/LE-JHP (437) • DGAD/HGAD (436) • DGFH (252) • DGFH-JHP (253) • DGFS (427) • DGTR/L (433) • HELIIR/L (339) • HELIR/L (250) • HFAER/L-4 (551) • HFAER/L-5T, 6T (552) • HFAIR/L-4 (554) • HFAIR/L-DG (555) • HFFR/L-T (550) • HFHR/L-4T (548) • HFHR/L-5T (548) • HFHR/L-6T (549) • HFIR/L-MC (556) • HFPAD-3 (549) • HFPAD-4 (549) • HFPAD-5 (550) • HFPAD-6 (550) • HGAER/L-3 (551) • HGAIIR/L-3 (554) • HGFH (251) • HGHR/L-3 (547) • HGPAD (251) • HGPAD-JHP (251) • IM-HFIR-MC (556)

TGDR/L
External Holders for Turning, Grooving and Profiling

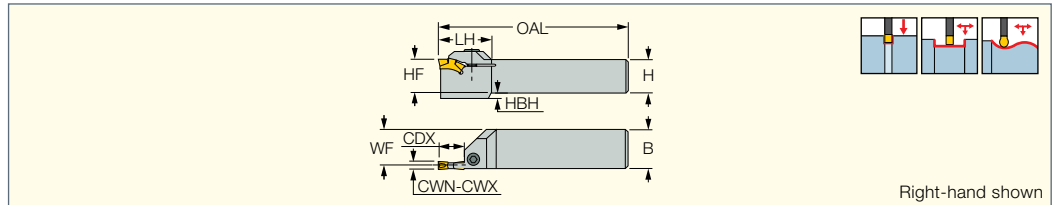

Designation	CWN ⁽¹⁾	CWX ⁽²⁾	CDX ⁽³⁾	H	HF	B	OAL	LH	WF	HBH	Insert		
TGDR/L 1616-3M	3.00	3.00	7.50	16.0	16.0	16.0	100.00	30.5	14.80	6.0	TGMF 3	SR M5X12 DIN912	HW 4.0
TGDR/L 2020-3M	3.00	3.00	7.50	20.0	20.0	20.0	125.00	30.5	18.70	-	TGMF 3	SR M5X12 DIN912	HW 4.0
TGDR/L 2525-3M	3.00	3.00	7.50	25.0	25.0	25.0	140.00	30.5	23.70	-	TGMF 3	SR M5X12 DIN912	HW 4.0
TGDR/L 1616-4M	4.00	5.00	9.00	16.0	16.0	16.0	100.00	32.2	14.20	6.0	TGMF 4/TGMF 5	SR M5X12 DIN912	HW 4.0
TGDR/L 2020-4M	4.00	5.00	9.00	20.0	20.0	20.0	125.00	32.2	18.20	6.0	TGMF 4/TGMF 5	SR M5X12 DIN912	HW 4.0
TGDR/L 2525-4M	4.00	5.00	15.50	25.0	25.0	25.0	140.00	34.0	23.20	-	TGMF 4/TGMF 5	SR M5X12 DIN912	HW 4.0
TGDR/L 2525-5M	5.00	5.00	18.00	25.0	25.0	25.0	140.00	37.0	22.70	-	TGMF 5	SR M5X12 DIN912	HW 4.0
TGDR/L 3232-5M	5.00	5.00	22.00	32.0	32.0	32.0	150.00	45.0	29.80	-	TGMF 5	SR M6X12 DIN912	HW 5.0
TGDR/L 2525-6M	6.00	6.35	22.00	25.0	25.0	25.0	150.00	43.0	22.50	-	TGMF 6	SR M6X16 DIN912	HW 5.0
TGDR/L 3232-6M	6.00	6.35	22.00	32.0	32.0	32.0	150.00	43.0	29.50	-	TGMF 6	SR M6X16 DIN912	HW 5.0

• For user guide, see pages 380-395

⁽¹⁾ Minimum cutting width

⁽²⁾ Maximum cutting width

⁽³⁾ Grooving depth is limited by the insert

TOP GRIP
MODULAR GRIP

TGPAD
Adapters Carrying TGMF /
TGMP Groove-Turn Inserts

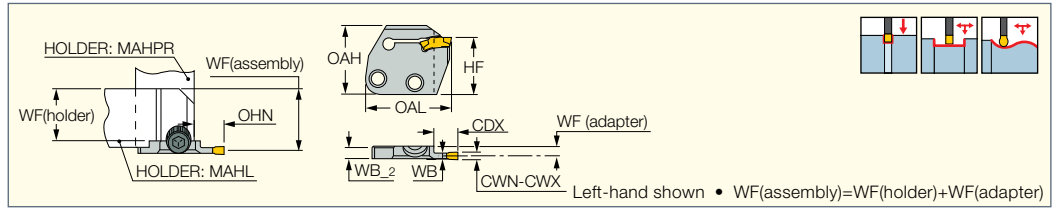

Designation	CWN ⁽¹⁾	CWX ⁽²⁾	CDX ⁽³⁾	WF ⁽⁴⁾	WB	WB_2	OHN ⁽⁵⁾	OAL	HF	OAH
TGPAD 3R/L-T9	3.00	3.00	9.00	4.00	2.40	5.2	12.7	37.20	24.0	30.0
TGPAD 4R/L-T16	4.00	5.00	16.00	3.50	3.40	5.2	17.2	41.70	24.0	30.0
TGPAD 5L-T16	5.00	5.00	16.00	3.00	4.40	5.2	17.2	41.70	24.0	30.0
TGPAD 6R/L-T22	6.00	6.35	22.00	3.50	5.00	6.0	23.2	47.10	24.0	32.0

- For user guide, see pages 380-395
- (1) Minimum cutting width
- (2) Maximum cutting width
- (3) Grooving depth is limited by the insert
- (4) WF(adapter)
- (5) Minimum overhang

TOP GRIP JETCUT
MODULAR GRIP

TGPAD-JHP
Adapters with Channels for High
Pressure Coolant Carrying TGMF
/ TGMP Groove-Turn Inserts

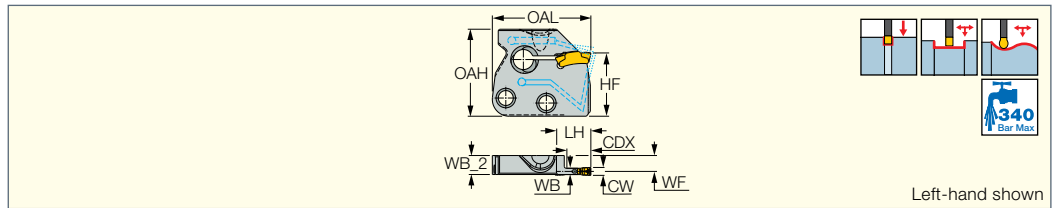

Designation	CWN ⁽¹⁾	CWX ⁽²⁾	CDX ⁽³⁾	WF	WB	WB_2	LH	OAL	HF	OAH
TGPAD 3R/L-T9-JHP	3.00	3.00	9.00	4.00	2.40	5.2	12.7	37.20	24.0	30.0
TGPAD 4R/L-T16-JHP	4.00	5.00	16.00	3.50	3.40	5.2	17.2	41.70	24.0	30.0
TGPAD 5L-T16-JHP	5.00	5.00	16.00	3.00	4.40	5.2	17.2	41.70	24.0	30.0
TGPAD 6R/L-T22-JHP	6.00	6.35	22.00	3.50	5.00	6.0	23.2	47.10	24.0	32.0

- For user guide, see pages 380-400
- (1) Minimum cutting width
- (2) Maximum cutting width
- (3) Grooving depth is limited by the insert

Flow Rate vs. Pressure

Designation	70 Bar	100 Bar	140 Bar
	Flow Rate (liters/min)	Flow Rate (liters/min)	Flow Rate (liters/min)
TGPAD 3R/L-T9-JHP	11-17	17-23	23-26
TGPAD 4R/L-T16-JHP	20-25	25-31	31-34
TGPAD 5R/L-T16-JHP	27-33	33-39	39-43
TGPAD 6R/L-T22-JHP	30-35	35-41	41-44



TOP GRIP

TGHN-D
Double-Ended Blades
Carrying Utility Inserts for
Grooving and Turning

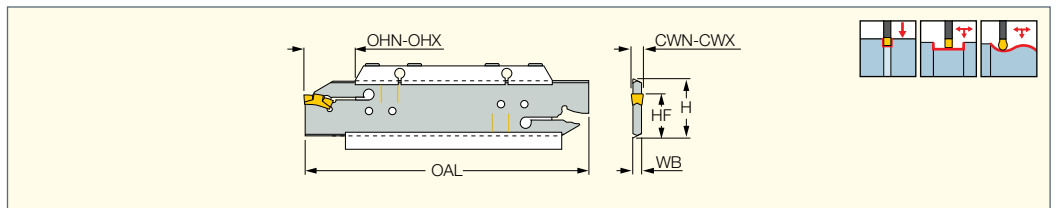

Designation	H	CWN ⁽¹⁾	CWX ⁽²⁾	OHN ⁽³⁾	OHX ⁽⁴⁾	HF	OAL	WB	Insert
TGHN 26-3D	26.0	3.00	3.00	10.0	15.0	21.4	110.00	2.40	TGMF 3
TGHN 26-4D	26.0	4.00	5.00	10.0	15.0	21.4	110.00	3.20	TGMF 4, TGMF/P 5
TGHN 26-5D	26.0	5.00	5.00	10.0	20.0	21.4	110.00	4.00	TGMF/P 5
TGHN 32-3D	32.0	3.00	3.00	10.0	18.0	24.8	150.00	2.40	TGMF 3
TGHN 32-4D	32.0	4.00	5.00	12.0	21.0	24.8	150.00	3.20	TGMF 4, TGMF/P 5
TGHN 32-5D	32.0	5.00	5.00	12.0	26.0	24.8	150.00	4.00	TGMF/P 5
TGHN 32-6D	32.0	6.00	6.35	16.0	26.0	24.8	150.00	5.20	TGMF 6

- Use the drilled holes on blade for min. and max. overhang
- Grooving depth is limited by the insert
- For user guide, see pages 380-395
- (1) Minimum cutting width
- (2) Maximum cutting width
- (3) Minimum overhang
- (4) Maximum overhang

For inserts, see pages: TGMA (258) • TGMF (full radius) (257) • TGMF/P (257)
For holders, see pages: SGTBU/SGTBN (586) • UBHCR/L (587)

TOP GRIP

TGHN-S

Single-Ended Blades
Carrying Utility Inserts for
Grooving and Turning

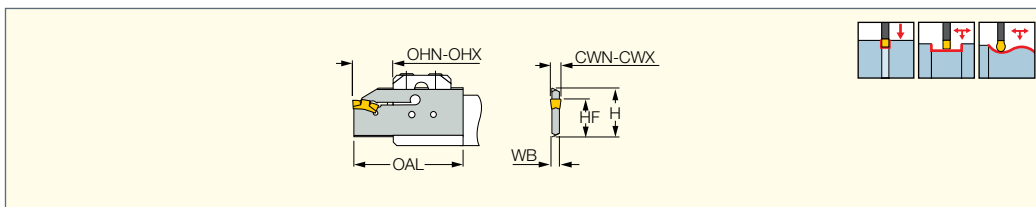

Designation	H	CWN ⁽¹⁾	CWX ⁽²⁾	OHN ⁽³⁾	OHX ⁽⁴⁾	HF	OAL	WB	Insert
TGHN 32-3S	32.0	3.00	3.00	10.0	18.0	24.8	48.30	2.40	TGMF 3
TGHN 32-5S	32.0	5.00	5.00	12.0	25.0	24.8	54.00	4.00	TGMF/P 5
TGHN 32-6S	32.0	6.00	6.35	16.0	25.0	24.8	55.70	5.20	TGMF 6

• Use the drilled holes on blade for min. and max. overhang • Grooving depth is limited by the insert • For user guide, see pages 380-395

- (1) Minimum cutting width
- (2) Maximum cutting width
- (3) Minimum overhang
- (4) Maximum overhang

For inserts, see pages: TGMA (258) • TGMF (full radius) (257) • TGMF/P (257)

For holders, see pages: C#-TBU (591) • IM-TBU (598) • UBHCR/L (587)

TOP GRIP

TGMF/P

Utility Double-Ended Inserts
for External and Internal
Grooving and Turning

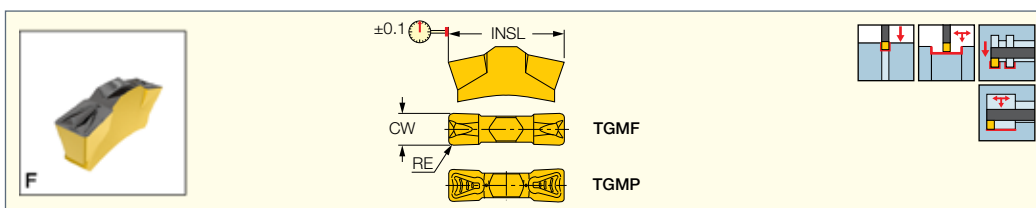

Designation	Dimensions						Tough ↔ Hard						Recommended Machining Data		
	CW	RE	CWTOL ⁽¹⁾	RETOL ⁽²⁾	INSL	CDX	IC830	IC8250	IC808	IC20	IC20N	IC428	a _p (mm)	f turn (mm/rev)	f groove (mm/rev)
TGMF 302	3.00	0.20	0.05	0.050	13.50	10.50	●	●	●	●	●	●	0.25-1.80	0.14-0.18	0.07-0.11
TGMF 304	3.00	0.40	0.05	0.050	13.55	10.30	●	●	●	●	●	●	0.50-1.80	0.16-0.20	0.07-0.12
TGMF 402	4.00	0.20	0.05	0.050	17.70	14.70	●	●	●	●	●	●	0.20-2.40	0.16-0.21	0.09-0.14
TGMF 404	4.00	0.40	0.05	0.050	17.70	14.60	●	●	●	●	●	●	0.50-2.40	0.18-0.24	0.09-0.15
TGMF 508	5.00	0.80	0.05	0.050	17.80	14.20	●	●	●	●	●	●	1.00-3.00	0.23-0.35	0.11-0.21
TGMP 506	5.00	0.60	0.05	0.050	17.60	15.00	●	●	●	●	●	●	0.75-3.00	0.21-0.32	0.11-0.20
TGMF 635-080	6.35	0.80	0.05	0.050	22.15	18.60	●	●	●	●	●	●	1.00-3.80	0.25-0.44	0.14-0.27

• DMIN for internal application=20.5 mm • For cutting speed recommendations and user guide, see pages 380-395

- (1) Cutting width tolerance (+/-)
- (2) Corner radius tolerance (+/-)

For tools, see pages: TGDR/L (255) • TGHN 26-M (338) • TGHN-D (256) • TGHN-S (257) • TGIR/L-C (338) • TGPAD (256) • TGPAD-JHP (256)

TOP GRIP

TGMF (full radius)

Utility Double-Ended Full
Radius Inserts for External and
Internal Grooving and Profiling

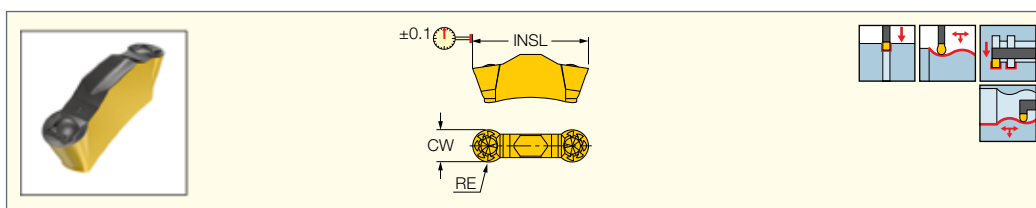

Designation	Dimensions						Tough ↔ Hard						Recommended Machining Data		
	CW	RE	CWTOL ⁽¹⁾	RETOL ⁽²⁾	INSL	CDX	IC830	IC8250	IC808	IC20	IC5010	IC428	a _p (mm)	f turn (mm/rev)	f groove (mm/rev)
TGMF 315	3.00	1.50	0.05	0.050	13.50	11.40	●	●	●	●	●	●	0.00-1.50	0.18-0.26	0.07-0.13
TGMF 420	4.00	2.00	0.05	0.050	17.80	14.90	●	●	●	●	●	●	0.00-2.00	0.20-0.34	0.09-0.17
TGMF 525	5.00	2.50	0.05	0.050	17.75	14.30	●	●	●	●	●	●	0.00-2.50	0.23-0.42	0.11-0.21
TGMF 630	6.00	3.00	0.05	0.050	22.15	18.30	●	●	●	●	●	●	0.00-3.00	0.24-0.50	0.13-0.25

• Can cut arcs to 250° • DMIN for internal application=20.5 mm • For cutting speed recommendations and user guide, see pages 380-395

- (1) Cutting width tolerance (+/-)
- (2) Corner radius tolerance (+/-)

For tools, see pages: TGDR/L (255) • TGHN 26-M (338) • TGHN-D (256) • TGHN-S (257) • TGIR/L-C (338) • TGPAD (256) • TGPAD-JHP (256)

TOPGRIP

TGMA

Utility Double-Ended Inserts for External and Internal Grooving and Turning of Cast Iron

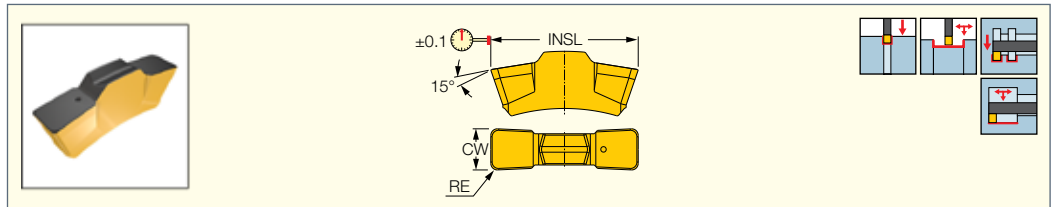

Designation	Dimensions						IC5010	Recommended Machining Data		
	CW	RE	CWTOL ⁽¹⁾	RETOL ⁽²⁾	INSL	CDX		ap (mm)	f turn (mm/rev)	f groove (mm/rev)
TGMA 304K	3.00	0.40	0.05	0.050	13.50	10.30	●	0.50-1.80	0.12-0.20	0.07-0.13
TGMA 404K	4.00	0.40	0.05	0.050	18.00	14.80	●	0.50-2.40	0.16-0.27	0.09-0.18
TGMA 408K	4.00	0.80	0.05	0.050	18.00	14.50	●	1.00-2.40	0.18-0.32	0.09-0.19
TGMA 508K	5.00	0.80	0.05	0.050	18.00	15.00	●	1.00-3.00	0.23-0.40	0.11-0.24
TGMA 608K	6.00	0.80	0.05	0.050	22.40	18.60	●	1.00-3.60	0.27-0.48	0.14-0.29

⁽¹⁾ Cutting width tolerance (+/-)

⁽²⁾ Corner radius tolerance (+/-)

For tools, see pages: TGDR/L (255) • TGHN 26-M (338) • TGHN-D (256) • TGHN-S (257) • TGIR/L-C (338) • TGPAD (256)

CUTGRIP

GHMR/L

Toolholders for Shallow Radial and Axial Grooving with Narrow and Special Profile Inserts

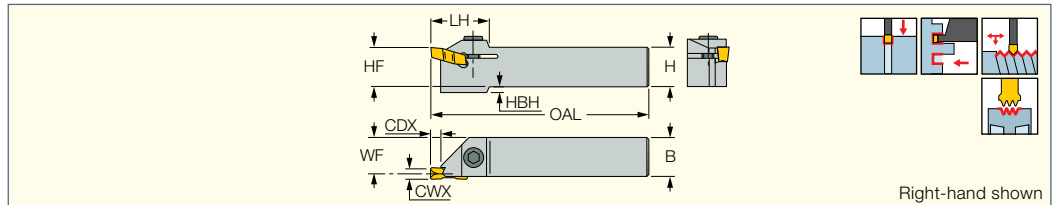

Right-hand shown

Designation	CWX ⁽²⁾	CDX ⁽³⁾	H	HF	B	OAL	LH	WF	HBH		
GHMR/L 12	4.00	4.80	12.0	12.0	12.0	110.00	25.0	10.80	4.0	SR M6X16 DIN912	T-20/5
GHMR/L 16	4.80	4.80	16.0	16.0	16.0	115.00	25.0	14.50	-	SR M6X16 DIN912	HW 5.0
GHMR 16-3 ST ⁽¹⁾	5.00	4.80	16.0	16.0	16.0	78.00	25.0	15.00	-	SR M6X16 DIN912	HW 5.0
GHMR/L 20	6.40	4.80	20.0	20.0	20.0	125.00	25.0	18.50	-	SR M6X16 DIN912	HW 5.0
GHMR/L 25	6.40	4.80	25.0	25.0	25.0	140.00	25.0	23.50	-	SR M6X16 DIN912	HW 5.0
GHMR/L 32	6.40	4.80	32.0	32.0	32.0	150.00	25.0	30.20	-	SR M6X16 DIN912	HW 5.0

• Use for recessing: light turning, small depth of cut (ap=0.1-0.5 mm) and small feed (f=0.1 mm/rev) • For user guide, see pages 380-395

⁽¹⁾ For Star and multi-spindle machines

⁽²⁾ Maximum cutting width

⁽³⁾ Cutting depth maximum

CUTGRIP

GHMPR/L

Perpendicular Toolholders for Shallow Radial and Axial Grooving with Narrow and Special Profile Inserts

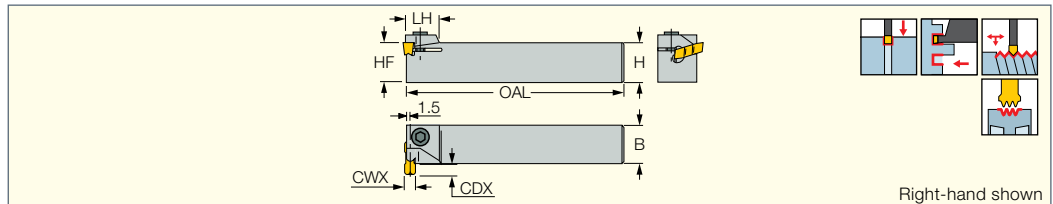

Right-hand shown

Designation	CWX ⁽¹⁾	CDX ⁽²⁾	H	HF	B	OAL	LH		
GHMPR/L 16	4.80	4.80	16.0	16.0	16.0	110.00	17.0	SR M6X16 DIN912	HW 5.0
GHMPR/L 20	6.40	4.80	20.0	20.0	20.0	120.00	17.0	SR M6X16 DIN912	HW 5.0
GHMPR/L 25	6.40	4.80	25.0	25.0	25.0	135.00	17.0	SR M6X16 DIN912	HW 5.0

• Use for recessing: light turning, small depth of cut (ap=0.1-0.5 mm) and small feed (f=0.1 mm/rev) • For user guide, see pages 380-395

⁽¹⁾ Maximum cutting width

⁽²⁾ Cutting depth maximum

CUTGRIP CAMFIX

C#-GHDR/L

External Grooving, Turning and Parting Toolholders with CAMFIX Exchangeable Tapered Shanks

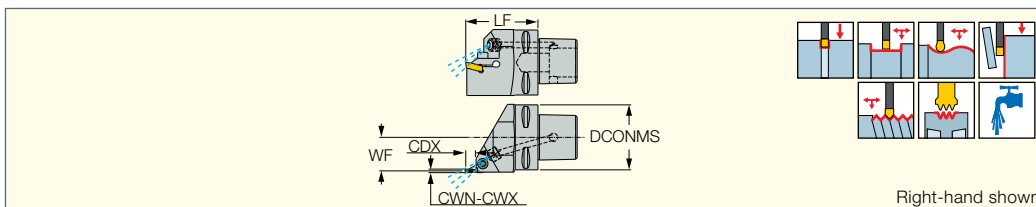

Designation	CWN ⁽²⁾	CWX ⁽³⁾	DCONMS	CDX	LF	WF			
C4 GHDR/L-3	2.80	4.00	40	9.00	55.00	20.00	SR M5X20DIN912	HW 4.0	EZ 104
C5 GHDR/L-3	2.80	4.00	50	9.00	55.00	24.00	SR M5X20DIN912	HW 4.0	EZ 104
C6 GHDR/L-3	2.80	4.00	63	9.00	55.00	32.00	SR M5X16 DIN912	HW 4.0	EZ 125
C4 GHDR/L-4	4.00	5.00	40	10.00	55.00	20.00	SR M6X20 DIN912	HW 5.0	EZ 104
C5 GHDR/L-4	4.00	5.00	50	10.00	55.00	24.00	SR M6X20 DIN912	HW 5.0	EZ 104
C6 GHDR/L-4	4.00	5.00	63	10.00	55.00	32.00	SR M6X16 DIN912	HW 5.0	EZ 125
C5 GHDR/L-5	5.00	6.40	50	12.00	55.00	24.00	SR M6X25 DIN912	HW 5.0	EZ 104
C6 GHDR/L-5	5.00	6.40	63	12.00	55.00	32.00	SR M6X16 DIN912	HW 5.0	EZ 125
C6 GHDR/L-8 ⁽¹⁾	7.00	8.40	63	25.00	70.00	30.00	SR M6X20 DIN912	HW 5.0	EZ 146

• When using GPV and TIP inserts, toolholder must be modified according to insert profile to ensure clearance

⁽¹⁾ Used with GIF 8, GIA 8, GIPA 8, GDMM, GIDA, GDMY, GDMF, GDMU inserts

⁽²⁾ Minimum cutting width

⁽³⁾ Maximum cutting width

For inserts, see pages: GDMF (271) • GDMM-CC (565) • GDMN (273) • GDMU (273) • GDMY (272) • GDMY (full radius) (274) • GDMY-F (275) • GIA-K (long pocket) (282) • GIA-K (W=3-6) (282) • GIF (281) • GIF (full radius) (282) • GIF (long pocket) (281) • GIF-E (W=4-6 full radius) (277) • GIF-E (W=4-6) (275) • GIF-E (W=8,10 full radius) (277) • GIF-E (W=8,10) (276) • GIM-C (473) • GIM-J (473) • GIM-J-RA/LA (474) • GIM-UT (475) • GIM-UT-RA/LA (475) • GIM-W (474) • GIM-W-RA/LA (475) • GIMF (271) • GIMN (272) • GIMT (271) • GIMY (272) • GIMY (full radius) (273) • GIMY-F (274) • GIP (280) • GIP (full radius) (280) • GIP-E (276) • GIP-E (full radius) (278) • GIP-UN (287) • GIPA (full radius W=3-6) (285) • GIPA (W=3-6) (284) • GIPA/GIDA 8 (full radius) (286) • GIPM-A46 / GIP-1250 (358) • GIPY (284) • GITM (283) • GITM (full radius) (283) • GPV (288) • TIP-MT (290) • TIP-P-BSPT (293) • TIP-P-BSW (292) • TIP-P-ISO (291) • TIP-P-NPT (292) • TIP-P-UN (291) • TIP-WT (290)

CUTGRIP

GHDR/L (short pocket)

External Tools for Turning, Grooving and Parting

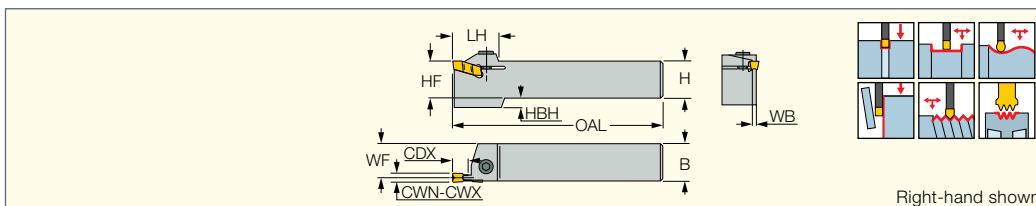

Designation	CWN ⁽⁴⁾	CWX ⁽⁵⁾	CDX ⁽⁶⁾	H	HF	B	OAL	LH	WF	WB	HBH		
GHDR/L 12-3	2.80	4.00	8.00	12.0	12.0	12.0	110.00	25.0	10.80	2.40	4.0	SR 76-1021	T-20/5
GHDR/L 16-3	2.80	4.00	9.00	16.0	16.0	16.0	110.00	26.0	14.80	2.40	4.0	SR M5X16 DIN912	HW 4.0
GHDR/L 16-3 ST ⁽¹⁾	2.80	4.00	9.00	16.0	16.0	16.0	78.00	24.0	15.00	2.20	4.0	SR M5X16 DIN912	HW 4.0
GHDR/L 20-3	2.80	4.00	9.00	20.0	20.0	20.0	120.00	26.0	18.80	2.40	-	SR M5X16 DIN912	HW 4.0
GHDR/L 25-3	2.80	4.00	9.00	25.0	25.0	25.0	135.00	26.0	23.80	2.40	-	SR M5X16 DIN912	HW 4.0
GHDR/L 16-4	4.00	5.00	10.00	16.0	16.0	16.0	110.00	26.0	14.40	3.20	4.0	SR M6X16 DIN912	HW 5.0
GHDR 16-4 ST ⁽¹⁾	4.00	5.40	10.00	16.0	16.0	16.0	78.00	24.6	14.00	3.40	4.0	SR M6X16 DIN912	HW 5.0
GHDR/L 20-4	4.00	5.00	10.00	20.0	20.0	20.0	120.00	26.0	18.40	3.20	-	SR M6X16 DIN912	HW 5.0
GHDR/L 25-4	4.00	5.00	10.00	25.0	25.0	25.0	135.00	27.0	23.40	3.20	-	SR M6X16 DIN912	HW 5.0
GHDR/L 32-4	4.00	5.00	10.00	32.0	32.0	32.0	150.00	27.0	30.40	3.20	-	SR M6X16 DIN912	HW 5.0
GHDR/L 20-5	5.00	6.40	12.00	20.0	20.0	20.0	120.00	29.0	17.90	4.20	-	SR M6X16 DIN912	HW 5.0
GHDR/L 25-5	5.00	6.40	12.00	25.0	25.0	25.0	135.00	29.0	22.90	4.20	-	SR M6X16 DIN912	HW 5.0
GHDR/L 32-5	5.00	6.40	12.00	32.0	32.0	32.0	150.00	29.0	29.90	4.20	-	SR M6X16 DIN912	HW 5.0
GHDR/L 25-6	6.00	6.40	12.00	25.0	25.0	25.0	135.00	29.0	22.30	5.40	-	SR M6X16 DIN912	HW 5.0
GHDR/L 25-P8 ⁽²⁾	7.00	10.00	16.50	25.0	25.0	25.0	150.00	35.7	21.80	6.50	-	SR M8X20 DIN912	HW 6.0
GHDR/L 32-P8 ⁽³⁾	7.00	10.00	16.50	32.0	32.0	32.0	170.00	35.7	28.80	6.50	-	SR M8X20 DIN912	HW 6.0

• For using TIP and GPV inserts, toolholder seat needs to be modified according to insert profile to ensure clearance. • For user guide, see pages 380-395

⁽¹⁾ For Star and multi-spindle machines.

⁽²⁾ Used with GIMF, GIMY, GIPY, GIMM, GITM, GPV inserts.

⁽³⁾ Used with GIMT, GIMN, GIMF, GIMY, GIPY, GIMM, GITM, GPV inserts

⁽⁴⁾ Minimum cutting width

⁽⁵⁾ Maximum cutting width

⁽⁶⁾ Cutting depth maximum

For inserts, see pages: GIA-K (W=3-6) (282) • GIF (281) • GIF (full radius) (282) • GIF-E (W=4-6 full radius) (277) • GIF-E (W=4-6) (275) • GIG (279) • GIM-C (473) • GIM-J (473) • GIM-J-RA/LA (474) • GIM-UT (475) • GIM-UT-RA/LA (475) • GIM-W (474) • GIM-W-RA/LA (475) • GIMF (271) • GIMM 8CC (565) • GIMN (272) • GIMT (271) • GIMY (272) • GIMY (full radius) (273) • GIMY-F (274) • GIP (280) • GIP (flat top W<M) (278) • GIP (full radius W<M) (279) • GIP (full radius) (280) • GIP-E (276) • GIP-E (full radius) (278) • GIP-UN (287) • GIPA (full radius W=3-6) (285) • GIPA (W=3-6) (284) • GIPM-A46 / GIP-1250 (358) • GIPY (284) • GITM (283) • GITM (full radius) (283) • GPV (288) • TIP-MT (290) • TIP-P-BSPT (293) • TIP-P-BSW (292) • TIP-P-ISO (291) • TIP-P-NPT (292) • TIP-P-UN (291) • TIP-WT (290)

For holders, see pages: C#-ASHR/L-45-HPMC (675) • C#-ASHR/L-HPMC (675)

CUTGRIP JETCUT

GHDR/L-JHP (short pocket)

Grooving and Turning
Tools with Channels for
High Pressure Coolant

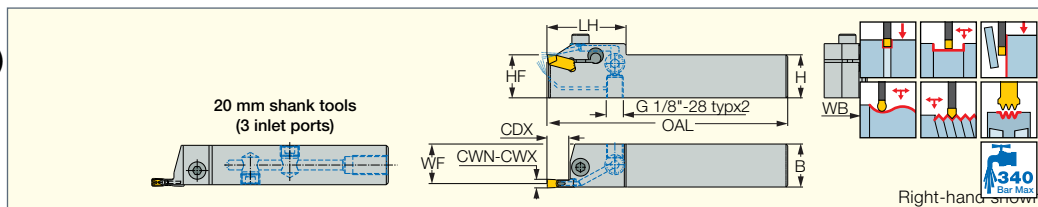

Designation	CWN ⁽²⁾	CWX ⁽³⁾	H	CDX ⁽⁴⁾	B	OAL	LH	WF	WB	HF
GHDR/L 20-3-JHP	2.80	4.00	20.0	9.00	20.0	120.00	29.0	18.80	2.40	20.0
GHDR/L 25-3-JHP	2.80	4.00	25.0	9.00	25.0	140.00	44.0	23.80	2.40	25.0
GHDR/L 20-4-JHP	4.00	5.00	20.0	10.00	20.0	120.00	29.0	18.40	3.20	20.0
GHDR/L 25-4-JHP	4.00	5.00	25.0	10.00	25.0	140.00	45.0	23.40	3.20	25.0
GHDR/L 25-5-JHP	5.00	6.40	25.0	12.00	25.0	140.00	46.0	22.90	4.20	25.0
GHDR/L 25-P8-JHP ⁽¹⁾	7.00	10.00	25.0	16.50	25.0	150.00	50.0	21.80	6.50	25.0

• For using TIP and GPV inserts, toolholder seat needs to be modified according to insert profile to ensure clearance • For user guide and accessories see pages 380-400

⁽¹⁾ Used with GIMF, GIMY, GIPY, GIMM, GITM, GPV, GIMY-F, GIMM 8CC, GIMT, GIMN, GITM (full radius), GIMY (full radius) inserts.

⁽²⁾ Minimum cutting width

⁽³⁾ Maximum cutting width

⁽⁴⁾ Cutting depth maximum



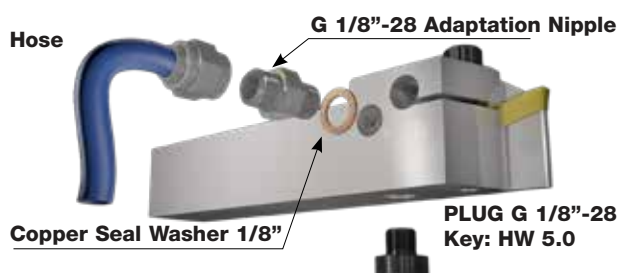

Flow Rate vs. Pressure

Designation	70 Bar	100 Bar	140 Bar
	Flow Rate (liters/min)	Flow Rate (liters/min)	Flow Rate (liters/min)
GHDR/L 20-3-JHP	5-7	7-9	9-11
GHDR/L 20-4-JHP	6-8	10-12	12-14
GHDR/L 25-3-JHP	6-8	8-10	10-12
GHDR/L 25-4-JHP	10-12	14-16	16-18
GHDR/L 25-5-JHP	13-16	19-21	22-24

GHDR...-JHP



Spare Parts

Designation				
GHDR/L 20-3-JHP	SR M5X16 DIN912	HW 4.0	PLUG G1/8-6.5 TL360	HW 5.0
GHDR/L 25-3-JHP	SR M5X20 DIN912	HW 4.0	PLUG G1/8ISO1179	HW 5.0
GHDR/L 20-4-JHP	SR M6X16 DIN912		PLUG G1/8-6.5 TL360	HW 5.0
GHDR/L 25-4-JHP	SR M6X20 DIN912		PLUG G1/8ISO1179	HW 5.0
GHDR/L 25-5-JHP	SR M6X20 DIN912		PLUG G1/8ISO1179	HW 5.0
GHDR/L 25-P8-JHP	SR M6X20 DIN912		PLUG G1/8ISO1179	HW 5.0



GHDR/L-JHP-MC (short pocket)

Grooving and Turning Tools with Bottom Inlet Coolant Channels

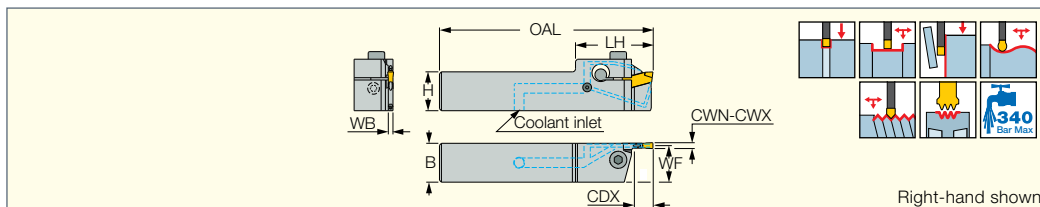

Designation	CWN ⁽¹⁾	CWX ⁽²⁾	H	CDX	B	OAL	LH	WF	WB
GHDR/L 20-3-JHP-MC	2.80	4.00	20.0	9.00	20.0	110.00	40.0	18.80	2.40
GHDR/L 25-3-JHP-MC	2.80	4.00	25.0	9.00	25.0	123.00	37.0	23.80	2.40
GHDR/L 20-4-JHP-MC	4.00	5.00	20.0	10.00	20.0	110.00	40.0	18.40	3.20
GHDR/L 25-4-JHP-MC	4.00	5.00	25.0	10.00	25.0	123.00	37.0	23.40	3.20
GHDR/L 25-5-JHP-MC	5.00	6.40	25.0	12.00	25.0	123.00	37.0	22.90	4.20



• For using TIP and GPV inserts, toolholder seat needs to be modified according to insert profile to ensure clearance • For user guide and accessories see pages 380-400

⁽¹⁾ Minimum cutting width

⁽²⁾ Maximum cutting width

For inserts, see pages: GIA-K (W=3-6) (282) • GIF (281) • GIF (full radius) (282) • GIF-E (W=4-6 full radius) (277) • GIF-E (W=4-6) (275) • GIM-C (473) • GIM-J (473) • GIM-J-RA/LA (474) • GIM-UT (475) • GIM-UT-RA/LA (475) • GIM-W (474) • GIM-W-RA/LA (475) • GIMF (271) • GIMM 8CC (565) • GIMN (272) • GIMT (271) • GIMY (272) • GIMY (full radius) (273) • GIMY-F (274) • GIP (280) • GIP (full radius) (280) • GIP-E (276) • GIP-E (full radius) (278) • GIP-UN (287) • GIPA (full radius W=3-6) (285) • GIPA (W=3-6) (284) • GIPM-A46 / GIP-1250 (358) • GIPY (284) • GITM (283) • GITM (full radius) (283) • GPV (288) • TIP-MT (290) • TIP-P-BSPT (293) • TIP-P-BSW (292) • TIP-P-ISO (291) • TIP-P-NPT (292) • TIP-P-UN (291) • TIP-WT (290)

Spare Parts

Designation		
GHDL 20-3-JHP-MC	SR M5X16 DIN912	HW 4.0
GHDR 20-3-JHP-MC	SR M5X16 DIN912	HW 4.0
GHDL 25-3-JHP-MC	SR M5X20DIN912	HW 4.0
GHDR 25-3-JHP-MC	SR M5X20DIN912	HW 4.0
GHDL 20-4-JHP-MC	SR M6X20 DIN912	HW 5.0
GHDR 20-4-JHP-MC	SR M6X20 DIN912	HW 5.0
GHDL 25-4-JHP-MC	SR M6X20 DIN912	HW 5.0
GHDR 25-4-JHP-MC	SR M6X20 DIN912	HW 5.0
GHDL 25-5-JHP-MC	SR M6X20 DIN912	HW 5.0
GHDR 25-5-JHP-MC	SR M6X20 DIN912	HW 5.0



CUTGRIP

GHGR/L

External Holders for Deep Grooving and Parting

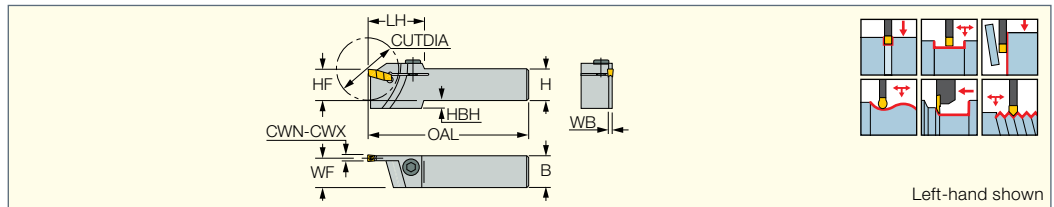

Designation	CWN ⁽³⁾	CWX ⁽⁴⁾	CUTDIA ⁽⁵⁾	H	HF	B	OAL	LH	WF	WB	HBH		
GHGR/L 20-2 ⁽¹⁾	0.40	2.40	34.0	20.0	20.0	20.0	120.00	33.0	19.20	1.70	-	SR M5X16 DIN912	HW 4.0
GHGR/L 25-2 ⁽¹⁾	0.40	2.40	34.0	25.0	25.0	25.0	140.00	33.0	24.20	1.70	-	SR M5X16 DIN912	HW 4.0
GHGR/L 16-3	3.00	4.00	40.0	16.0	16.0	16.0	110.00	36.0	14.70	2.50	4.0	SR M6X16 DIN912	HW 5.0
GHGR/L 16-3 ST ⁽²⁾	3.00	4.00	34.0	16.0	16.0	16.0	78.00	33.0	15.00	2.40	4.0	SR M6X16 DIN912	HW 5.0
GHGR/L 20-3	3.00	4.00	40.0	20.0	20.0	20.0	120.00	36.0	18.70	2.50	-	SR M6X16 DIN912	HW 5.0
GHGR/L 25-3	3.00	4.00	40.0	25.0	25.0	25.0	140.00	36.0	23.70	2.50	-	SR M6X16 DIN912	HW 5.0
GHGR 16-4	4.00	5.00	40.0	16.0	16.0	16.0	110.00	36.0	14.40	3.20	4.0	SR M6X16 DIN912	HW 5.0
GHGR/L 20-4	4.00	5.00	40.0	20.0	20.0	20.0	120.00	36.0	18.20	3.50	-	SR M6X16 DIN912	HW 5.0
GHGR/L 25-4	4.00	5.00	40.0	25.0	25.0	25.0	140.00	36.0	23.20	3.50	-	SR M6X16 DIN912	HW 5.0
GHGR/L 25-425	4.00	5.00	50.0	25.0	25.0	25.0	140.00	41.0	23.20	3.50	-	SR M6X16 DIN912	HW 5.0
GHGR/L 25-5	5.00	6.40	50.0	25.0	25.0	25.0	140.00	41.0	22.90	4.20	-	SR M6X16 DIN912	HW 5.0
GHGR/L 32-5	5.00	6.40	50.0	32.0	32.0	32.0	150.00	41.0	29.90	4.20	-	SR M6X16 DIN912	HW 5.0
GHGR/L 25-630	6.00	8.00	60.0	25.0	25.0	25.0	140.00	45.0	22.30	5.40	-	SR M6X16 DIN912	HW 5.0
GHGR/L 32-632	6.00	8.00	64.0	32.0	32.0	32.0	170.00	50.0	29.40	5.40	-	SR M6X16 DIN912	HW 5.0

• For machining depth over 13 mm, a single-ended insert is required (GIM, GIMF,GIMY,GIMT,GIMN) • CDX for grooving depth depends on part diameter CUTDIA • For grooving a part with a diameter larger than CUTDIA, see next table • For using TIP inserts, tool holder seat needs to be modified according to insert profile to ensure clearance

• For user guide, see pages 380-395

⁽¹⁾ In the case of inserts with CW<2 mm, tool pocket should be ground to 0.3 mm thinner than the insert's grooving width.

⁽²⁾ For Star and multi-spindle machines.

⁽³⁾ Minimum cutting width

⁽⁴⁾ Maximum cutting width

⁽⁵⁾ Maximum parting diameter

Depth Capacity*

Designation	CUTDIA												
	20	25	32	40	50	63	80	100	125	160	200	250	320
GHGR/L 16-3	—	—	—	—	40	50	68	80	120	290	1000	—	—
GHGR/L 20-2	—	—	—	—	—	—	66	80	120	270	1000	—	—
GHGR/L 20-3	—	—	—	—	40	50	68	80	120	290	1000	—	—
GHGR/L 20-4	—	—	—	—	40	50	68	80	120	290	1000	—	—
GHGR/L 25-2	—	—	—	—	—	—	66	72	86	110	130	220	320
GHGR/L 25-3	—	—	—	—	40	80	105	120	190	450	1500	—	—
GHGR/L 25-4	—	—	—	—	40	80	105	120	190	450	1500	—	—
GHGR/L 25-425	—	—	99	135	350	700	—	—	—	—	—	—	—
GHGR/L 25-5	—	—	50	130	300	600	—	—	—	—	—	—	—
GHGR/L 25-630	—	100	350	—	—	—	—	—	—	—	—	—	—
GHGR/L 32-5	—	—	50	130	300	600	—	—	—	—	—	—	—
GHGR 32-632	—	—	—	—	—	—	—	—	—	—	—	—	—
CDX	32	30	25	23	20	19	17	16	14	12	11	9	8

* For over 13 mm depth: GIM, GIMF,GIMT,GIMN and GIMY, GPV (single ended insert) only.

MODULARGRIP

MAHR/L

Adapter Holders for all GRIP Systems

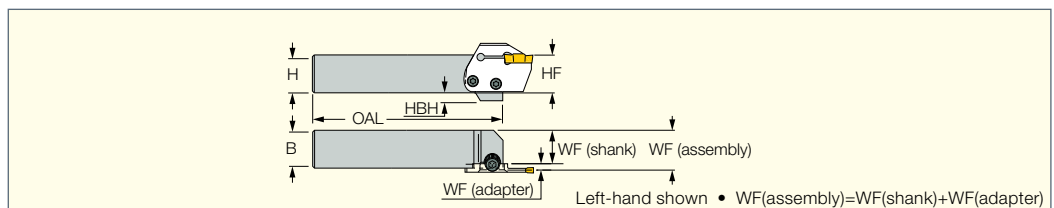

Designation	H	B	HF	OAL	HBH	WF ⁽¹⁾
MAHR/L 20	20.0	20.0	20.0	130.00	10.0	17.1
MAHR/L 25	25.0	25.0	25.0	130.00	5.0	22.1
MAHR/L 32	32.0	32.0	32.0	140.00	-	29.1

⁽¹⁾ WF(shank)

For tools, see pages: CGPAD (265) • DGAD-B-D (436) • DGAD/HGAD (436) • HFPAD-3 (549) • HFPAD-4 (549) • HFPAD-5 (550) • HFPAD-6 (550) • HGPAD (251) • PCADR/L (300) • SCLCR-PAD (50) • SDJCR-PAD (54) • SVJCR-PAD (60) • SWAPR-PAD (66) • TGAD (455) • TGPAD (256) • TTADR/L-JHP (651)

Spare Parts

Designation						
MAHR/L	SR M5-04451	T-20/5	SR 14-519	SR M6X20-XT ^(a)	HW 5.0	SR M6X6 DIN551 14H/22H

^(a) For CGPAD, HGPAD, TGPAD and HFPAD adapters; supplied with the tools

MAHR/L-JHP

Holders with High Pressure Coolant Channels for MODULAR-GRIP Adapters

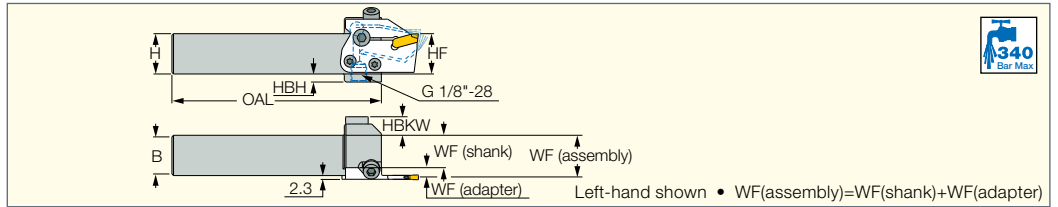

Designation	H	B	OAL	HBH	WF ⁽¹⁾	HBKW	HF
MAHR/L 20-JHP	20.0	20.0	130.00	10.0	15.1	16.50	20.0
MAHR/L 25-JHP	25.0	25.0	130.00	5.0	20.1	11.50	25.0
MAHR/L 32-JHP	32.0	32.0	140.00	-	27.1	4.50	32.0

• For user guide and accessories, see pages 380-400

⁽¹⁾ WF(shank)

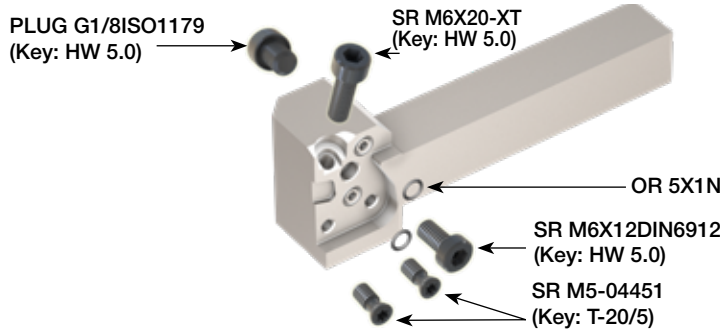

Spare Parts

Designation							
MAHR/L-JHP	SR M5-04451	T-20/5	SR M6X12DIN6912	SR M6X20-XT	HW 5.0	OR 5X1N	PLUG G1/8ISO1179

MAHR/L-JHP-MC

Holders with Bottom Inlets for High Pressure Coolant Channels Carrying MODULAR-GRIP Grooving and Turning Adapters

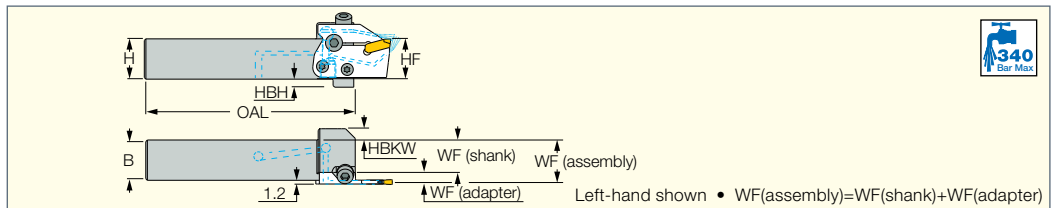

Designation	H	B	OAL	HBH	WF ⁽¹⁾	HBKW	HF
MAHR/L 20-JHP-MC	20.0	20.0	98.00	10.0	14.0	6.00	20.0
MAHR/L 25-JHP-MC	25.0	25.0	98.00	5.0	19.0	-	25.0

• For CDX, refer to the adapters data.

⁽¹⁾ WF(shank)

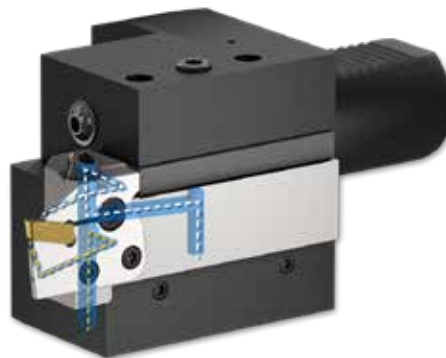

Spare Parts

Designation						
MAHR/L-JHP-MC	SR M6X20-XT	HW 5.0	SR M5-04451	T-20/5	SR M6X12DIN6912	OR 5X1N

MODULAR GRIP

MAHPR/L

Holders for Perpendicularly Mounted Adapters for all GRIP Systems

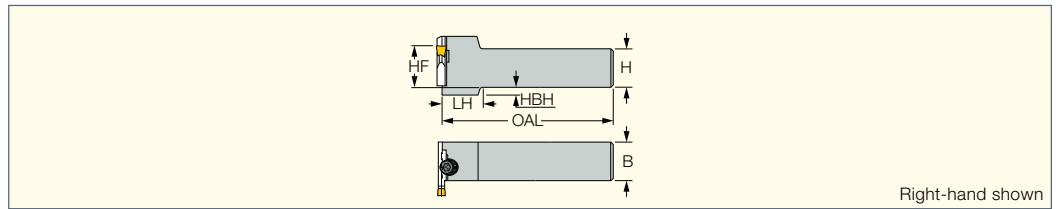

Designation	H	B	HF	OAL	LH	HBH
MAHPR/L 20	20.0	20.0	20.0	140.00	25.0	10.0
MAHPR/L 25	25.0	25.0	25.0	140.00	25.0	5.0
MAHPR/L 32	32.0	32.0	32.0	150.00	25.0	-

Spare Parts

Designation						
MAHPR/L	SR M5-04451	T-20/5	SR 14-519	SR M6X20-XT ^(a)	HW 5.0	SR M6X6 DIN551 14H/22H

^(a) For CGPAD, HGPAD, TGPAD and HFPAD adapters. Supplied with the tools.

MODULAR GRIP

JET CUT

MAHPR/L-JHP

Holders with High Pressure Coolant Channels for MODULAR-GRIP Perpendicularly Mounted Adapters

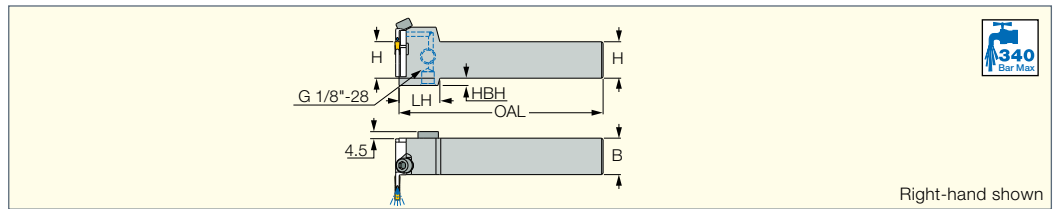

Designation	H	B	OAL	LH	HBH
MAHPR/L 20-JHP	20.0	20.0	140.00	28.0	10.0
MAHPR/L 25-JHP	25.0	25.0	140.00	28.0	5.0
MAHPR/L 32-JHP	32.0	32.0	150.00	-	-

• For user guide and accessories, see pages 380-400

For tools, see pages: DGPAD-JHP (437) • TAGPAD-JHP (456) • TGPAD-JHP (256) • TTADR/L-JHP (651) • CGPAD-JHP (265) • HGPAD-JHP (251) • PCADR/L-JHP (301) • CGPAD (265) • DGAD-B-D (436) • DGAD/HGAD (436) • HFPAD-3 (549) • HFPAD-4 (549) • HFPAD-5 (550) • HFPAD-6 (550) • HGPAD (251) • PCADR/L (300) • SCLCR-PAD (50) • SDJCR-PAD (54) • SVJCR-PAD (60) • SWAPR-PAD (66) • TGAD (455) • TGPAD (256)

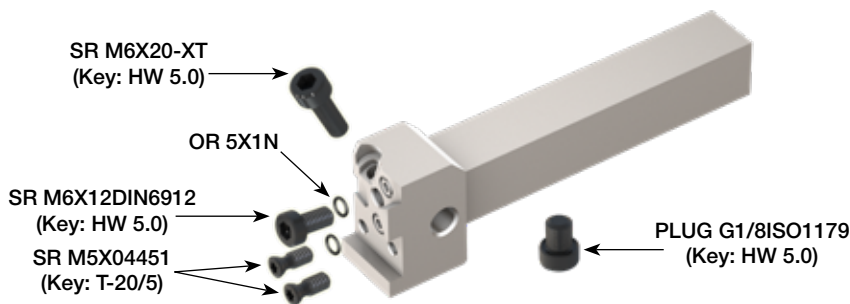

Spare Parts

Designation							
MAHPR/L-JHP	SR M5-04451	T-20/5	SR M6X12DIN6912	SR M6X20-XT	HW 5.0	OR 5X1N	PLG 1/8ISO1179

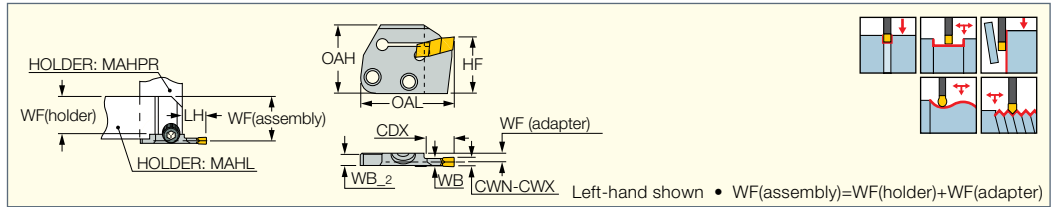

Designation	CWN ⁽¹⁾	CWX ⁽²⁾	CDX ⁽³⁾	LH	WF ⁽⁴⁾	WB	WB_2	OAL	OAH	HF
CGPAD 3R/L-T16	2.80	4.00	16.00	17.3	4.00	2.40	5.2	42.00	30.0	24.0
CGPAD 3R/L-T22	2.80	4.00	22.00	23.0	4.00	2.40	5.2	47.70	30.0	24.0
CGPAD 4L-T16	4.00	5.00	16.00	17.3	3.60	3.50	5.2	42.00	30.0	24.0
CGPAD 4L-T22	4.00	5.00	22.00	23.0	3.50	3.50	5.2	47.70	30.0	24.0
CGPAD 5L-T16	5.00	6.40	16.00	17.3	3.10	4.50	5.2	42.00	30.0	24.0
CGPAD 5L-T22	5.00	6.40	22.00	23.0	3.00	4.50	5.2	47.70	30.0	24.0
CGPAD 8L-T16	6.40	8.00	16.00	17.3	3.00	6.00	6.0	42.00	30.0	24.0
CGPAD 8L-T22	6.40	8.00	22.00	23.0	3.00	6.00	6.0	47.70	30.0	24.0

• For using TIP insert, toolholder seat needs to be modified according to insert profile to ensure clearance • For user guide, see pages 380-395

- (1) Minimum cutting width
- (2) Maximum cutting width
- (3) Cutting depth maximum
- (4) WF(adapter)

For inserts, see pages: GIF (281) • GIF (full radius) (282) • GIF-E (W=4-6 full radius) (277) • GIF-E (W=4-6) (275) • GIM-C (473) • GIM-J (473) • GIM-J-RA/LA (474) • GIM-UT (475) • GIM-UT-RA/LA (475) • GIM-W (474) • GIM-W-RA/LA (475) • GIMF (271) • GIMM 8CC (565) • GIMN (272) • GIMT (271) • GIMY (272) • GIMY (full radius) (273) • GIMY-F (274) • GIP (280) • GIP (full radius) (280) • GIP-E (276) • GIP-E (full radius) (278) • GIP-UN (287) • GIPA (full radius W=3-6) (285) • GIPA (W=3-6) (284) • GIPM-A46 / GIP-1250 (358) • GIPY (284) • GITM (283) • GITM (full radius) (283) • TIP-MT (290) • TIP-P-BSPT (293) • TIP-P-BSW (292) • TIP-P-ISO (291) • TIP-P-NPT (292) • TIP-P-UN (291) • TIP-WT (290)

For holders, see pages: C#-MAHD-JHP (593) • C#-MAHPD-JHP (593) • MAHR/L-JHP-MC (263) • MAHPR/L-JHP (264) • MAHR/L-JHP (263) • MAHR/L (262) • MAHPR/L (264) • C#-MAHD (592) • C#-MAHPD (593) • C#-MAHUR/L (592) • C#-MAHDR-45 (591) • HSK A63WH-MAHUR/L (598) • HSK A63WH-MAHDR-45 (597) • HSK A63WH-MAHDOR (597) • IM-MAHD (599) • IM-MAHPD (599)

CUTGRIP JETCUT
MODULARGRIP

CGPAD-JHP

Adapters with High Pressure Coolant Channels Carrying CUT-GRIP Inserts

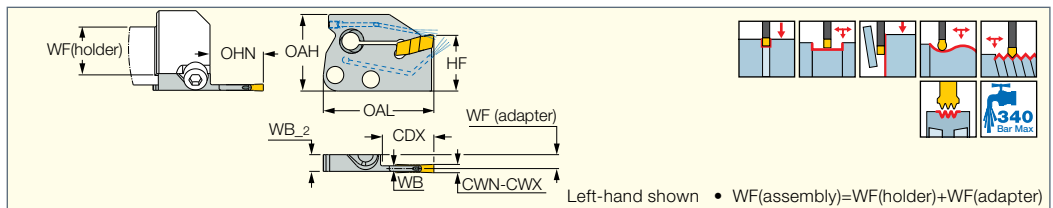

Designation	CWN ⁽¹⁾	CWX ⁽²⁾	CDX ⁽³⁾	OHN ⁽⁴⁾	WF ⁽⁵⁾	WB	WB_2	OAL	OAH	HF
CGPAD 3R/L-T16-JHP	2.80	4.00	16.00	17.3	6.00	2.40	7.2	42.00	33.0	24.0
CGPAD 3R-T22-JHP	2.80	4.00	22.00	23.0	6.00	2.40	7.2	47.70	33.0	24.0
CGPAD 4L-T16-JHP	4.00	5.00	16.00	17.3	5.45	3.50	7.2	42.00	33.0	24.0
CGPAD 5L-T16-JHP	5.00	6.40	16.00	17.3	4.95	4.50	7.2	42.00	33.0	24.0
CGPAD 8R/L-T22-JHP	6.40	8.00	22.00	23.0	4.20	6.00	7.2	47.00	33.0	24.0

• For using TIP insert, toolholder seat needs to be modified according to insert profile to ensure clearance • For user guide and accessories see pages 380-400

- (1) Minimum cutting width
- (2) Maximum cutting width
- (3) Cutting depth maximum
- (4) Minimum overhang
- (5) WF(adapter)

Flow Rate vs. Pressure

Designation	70 Bar	100 Bar	140 Bar
	Flow Rate (liters/min)	Flow Rate (liters/min)	Flow Rate (liters/min)
CGPAD 3R/L-T16-JHP	6-8	7-9	8-10
CGPAD 3R-T22-JHP	5-7	6-8	7-9
CGPAD 4R/L-T16-JHP	10-12	11-13	12-14
CGPAD 5R/L-T16-JHP	12-14	16-18	19-21

CUTGRIP

CGHN-S

External Machining
Single-Ended Blades

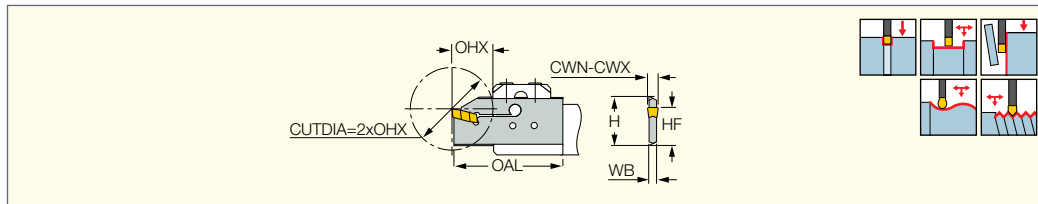

Designation	H	CWN ⁽¹⁾	CWX ⁽²⁾	OHN ⁽³⁾	OHX ⁽⁴⁾	HF	OAL	WB
CGHN 32-3S	32.0	2.80	4.00	10.0	19.0	24.8	51.00	2.40
CGHN 32-4S	32.0	3.50	5.00	12.0	21.0	24.8	53.00	3.20
CGHN 32-5S	32.0	4.40	6.40	12.0	25.0	24.8	56.00	4.00
CGHN 32-6S	32.0	5.50	6.40	12.0	25.0	24.8	56.00	5.20

• For user guide, see pages 380-395

- (1) Minimum cutting width
- (2) Maximum cutting width
- (3) Minimum overhang • When using a double-ended insert, grooving depth is limited by the insert
- (4) Maximum overhang

For inserts, see pages: GIA-K (W=3-6) (282) • GIF (281) • GIF (full radius) (282) • GIF-E (W=4-6 full radius) (277) • GIF-E (W=4-6) (275) • GIM-C (473) • GIM-J (473) • GIM-J-RA/LA (474) • GIM-UT (475) • GIM-UT-RA/LA (475) • GIM-W (474) • GIM-W-RA/LA (475) • GIMF (271) • GIMN (272) • GIMT (271) • GIMY (272) • GIMY (full radius) (273) • GIMY-F (274) • GIP (280) • GIP (full radius) (280) • GIP-E (276) • GIP-E (full radius) (278) • GIPA (full radius W=3-6) (285) • GIPA (W=3-6) (284) • GIPM-A46 / GIP-1250 (358) • GIPY (284) • GITM (283) • GITM (full radius) (283) • TIP-MT (290) • TIP-P-BSPT (293) • TIP-P-BSW (292) • TIP-P-ISO (291) • TIP-P-NPT (292) • TIP-P-UN (291) • TIP-WT (290)

For holders, see pages: C#-TBU (591) • IM-TBU (598) • UBHCR/L (587)

CUTGRIP

CGHN-D

Double-Ended Blades for
External Grooving and Turning

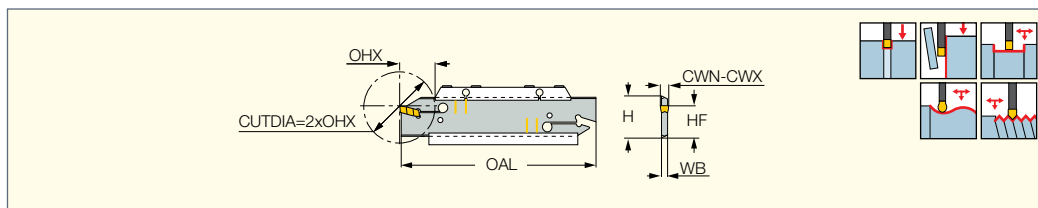

Designation	H	CWN ⁽¹⁾	CWX ⁽²⁾	OHN ⁽³⁾	OHX ⁽⁴⁾	HF	OAL	WB
CGHN 26-3D	26.0	2.80	4.00	10.0	15.0	21.4	110.00	2.40
CGHN 26-4D	26.0	3.50	4.50	10.0	15.0	21.4	110.00	3.20
CGHN 26-5D	26.0	4.40	6.40	10.0	20.0	21.4	110.00	4.00
CGHN 32-3D	32.0	2.80	4.00	10.0	19.0	24.8	150.00	2.40
CGHN 32-4D	32.0	3.50	5.00	12.0	21.0	24.8	150.00	3.20
CGHN 32-5D	32.0	4.40	6.40	12.0	26.0	24.8	150.00	4.00
CGHN 32-6D	32.0	5.50	6.40	12.0	26.0	24.8	150.00	5.20

• For user guide, see pages 380-395

- (1) Minimum cutting width
- (2) Maximum cutting width
- (3) Minimum overhang • When using a double-ended insert, grooving depth is limited by the insert
- (4) Maximum overhang

For inserts, see pages: GIA-K (W=3-6) (282) • GIF (281) • GIF (full radius) (282) • GIF-E (W=4-6 full radius) (277) • GIF-E (W=4-6) (275) • GIM-C (473) • GIM-J (473) • GIM-J-RA/LA (474) • GIM-UT (475) • GIM-UT-RA/LA (475) • GIM-W (474) • GIM-W-RA/LA (475) • GIMF (271) • GIMN (272) • GIMT (271) • GIMY (272) • GIMY (full radius) (273) • GIMY-F (274) • GIP (280) • GIP (full radius) (280) • GIP-E (276) • GIP-E (full radius) (278) • GIPA (full radius W=3-6) (285) • GIPA (W=3-6) (284) • GIPM-A46 / GIP-1250 (358) • GIPY (284) • GITM (283) • GITM (full radius) (283) • TIP-MT (290) • TIP-P-BSPT (293) • TIP-P-BSW (292) • TIP-P-ISO (291) • TIP-P-NPT (292) • TIP-P-UN (291) • TIP-WT (290)

For holders, see pages: SGTBU/SGTBN (586) • UBHCR/L (587)

CUTGRIP

CGHN-DG

Double-Ended Blades for External Grooving and Turning Self-Clamped Inserts

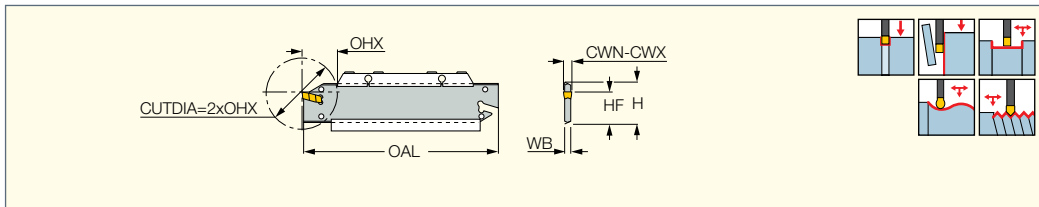

Designation	H	CWN ⁽¹⁾	CWX ⁽²⁾	OHX ⁽³⁾	OHX_2 ⁽⁴⁾	HF	OAL	WB	
CGHN 32-3DG	32.0	2.80	4.00	50.0	25.0	24.8	150.00	2.40	EDG 44A*
CGHN 32-4DG	32.0	3.50	5.00	50.0	30.0	24.8	150.00	3.20	EDG 44A*
CGHN 32-5DG	32.0	4.40	6.40	60.0	33.0	24.8	150.00	4.00	EDG 44A*
CGHN 32-6DG	32.0	5.50	6.40	60.0	35.0	24.8	150.00	5.20	EDG 44A*

- DO-GRIP clamping insert is self-retained for long overhang
- When using TIP inserts, toolholder seat needs to be modified according to insert profile to ensure clearance
- When using a double-ended insert, grooving depth is limited by the insert
- For user guide, see pages 380-395

- ⁽¹⁾ Minimum cutting width
- ⁽²⁾ Maximum cutting width
- ⁽³⁾ Maximum overhang for grooving
- ⁽⁴⁾ Maximum overhang for turning

* Optional, should be ordered separately

For inserts, see pages: GIA-K (W=3-6) (282) • GIF (281) • GIF (full radius) (282) • GIF-E (W=4-6 full radius) (277) • GIF-E (W=4-6) (275) • GIM-C (473) • GIM-J (473) • GIM-J-RA/LA (474) • GIM-UT (475) • GIM-UT-RA/LA (475) • GIM-W (474) • GIM-W-RA/LA (475) • GIMF (271) • GIMN (272) • GIMT (271) • GIMY (272) • GIMY (full radius) (273) • GIMY-F (274) • GIP (280) • GIP (full radius) (280) • GIP-E (276) • GIP-E (full radius) (278) • GIP-UN (287) • GIPA (full radius W=3-6) (285) • GIPA (W=3-6) (284) • GIPM-A46 / GIP-1250 (358) • GIPY (284) • GITM (283) • GITM (full radius) (283) • TIP-MT (290) • TIP-P-BSPT (293) • TIP-P-BSW (292) • TIP-P-ISO (291) • TIP-P-NPT (292) • TIP-P-UN (291) • TIP-WT (290)

For holders, see pages: C#-TBK-R/L (591) • HSK A-WH-TBK-R/L (598) • SGTBU/SGTBN (586) • UBHCR/L (587)

CUTGRIP

CGHN-P8

Blades for Deep Grooving and Turning

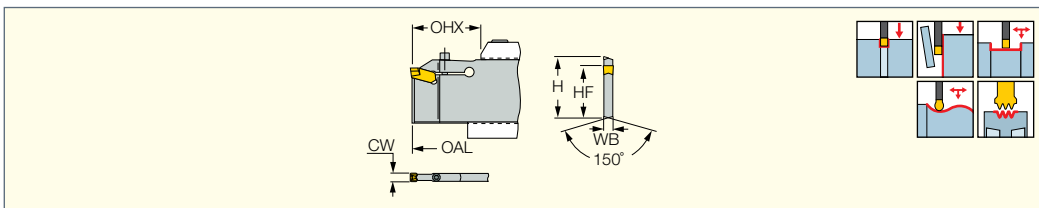

Designation	CW	OHX ⁽³⁾	CDX ⁽⁴⁾	WB	HF	H	OAL		
CGHN 52-P8 ⁽¹⁾	8.00	50.0	43.00	7.40	45.0	52.6	190.00	SR 76-1637	HW 4.0
CGHN 53-P8 ⁽²⁾	8.00	70.0	63.00	7.40	45.0	52.6	260.00	SR 76-1637	HW 4.0

• For user guide, see pages 380-395

⁽¹⁾ If CUTDIA (workpiece) is smaller than 200 mm, then CDX=48; if CUTDIA (workpiece) is larger than 200 mm, then CDX=43

⁽²⁾ If CUTDIA (workpiece) is smaller than 200 mm, then CDX=68; if CUTDIA (workpiece) is larger than 200 mm, then CDX=63

- ⁽³⁾ Maximum overhang
- ⁽⁴⁾ Cutting depth maximum

For inserts, see pages: GIMF (271) • GIMM 8CC (565) • GIMY (272) • GIMY (full radius) (273) • GIMY-F (274) • GIPY (284)

For holders, see pages: SGTBK (587) • SGTBU/SGTBN (586)

CUTGRIP

CGHR/L-P8DG

Double-Ended Heavy Duty Self-Clamped Grooving and Turning Blades

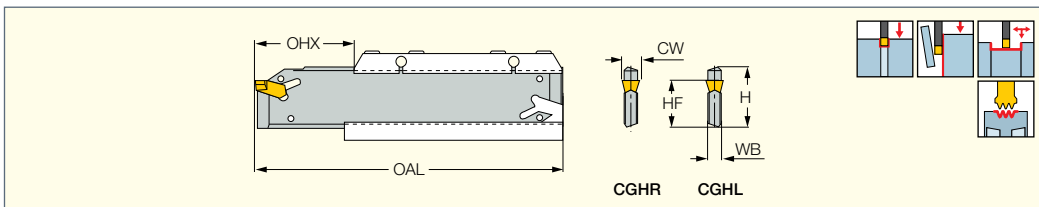

Designation	CW	OHX ⁽¹⁾	WB	HF	H	OAL	
CGHR/L 32-P8DG	8.00	40.0	6.80	24.8	32.0	150.00	EDG 44A*

• For user guide, see pages 380-395

⁽¹⁾ Minimum cutting width * Optional, should be ordered separately

For inserts, see pages: GIMF (271) • GIMM 8CC (565) • GIMY (272) • GIMY (full radius) (273) • GIMY-F (274) • GIPY (284)

For holders, see pages: C#-TBK-R/L (591) • HSK A-WH-TBK-R/L (598) • SGTBK (587) • SGTBU/SGTBN (586)

CUTGRIP

WHISPERLINE ANTI-VIBRATION

Anti-Vibration Blades
Anti-Vibration Blades for Deep Grooving and Turning

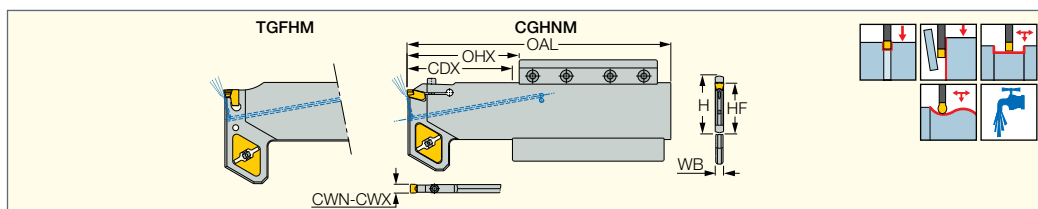

Designation	CWN ⁽¹⁾	CWX ⁽²⁾	OHX ⁽³⁾	CDX	WB	HF	H	OAL	Insert		
CGHNM 53-6DG-AV	5.50	6.40	100.0	93.00	5.20	45.0	52.6	235.00	GIMF/N/T/Y 6 GIM 6	SGCU 341*	EDG 44A*
TGFHM 53K-8-AV	7.70	9.00	100.0	93.00	7.40	45.0	52.6	235.00	TAG/TAGB 8	SGCU 341*	ETG 8-12*
CGHNM 53-P8-AV	8.00	8.00	100.0	93.00 ⁽⁴⁾	7.40	45.0	52.6	235.00	GIMY/F/MM 8	SGCU 341*	HW 4.0

• For user guide, see pages 380-395

⁽¹⁾ Minimum cutting width

⁽²⁾ Maximum cutting width

⁽³⁾ Maximum overhang

⁽⁴⁾ Cutting depth maximum * Optional, should be ordered separately

For inserts, see pages: GIA-K (W=3-6) (282) • GIF (281) • GIF (full radius) (282) • GIF-E (W=4-6 full radius) (277) • GIF-E (W=4-6) (275) • GIM-C (473) • GIMF (271) • GIMM 8CC (565) • GIMN (272) • GIMT (271) • GIMY (272) • GIMY (full radius) (273) • GIMY-F (274) • GIP (280) • GIP-E (276) • GIPA (full radius W=3-6) (285) • GIPA (W=3-6) (284) • GIPY (284) • GITM (283) • GITM (full radius) (283) • TAG N-C/W/M (463) • TAGB/TAGBA (319)

For holders, see pages: SGTBK (587) • SGTBU/SGTBN (586)

CUTGRIP

GHDR/L (long pocket)

External Tools for Grooving, Turning and Parting

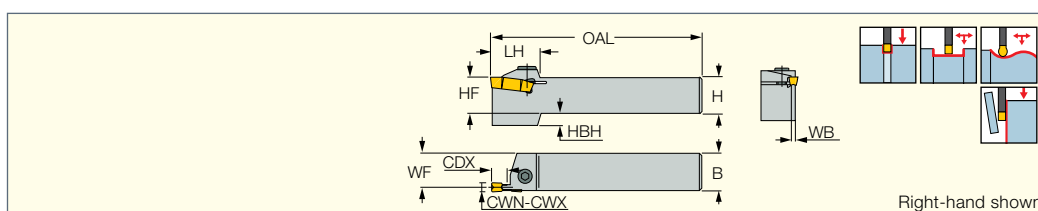

Designation	CWN ⁽¹⁾	CWX ⁽²⁾	CDX ⁽³⁾	H	B	OAL	WF	WB	LH	HBH	HF		
GHDR/L 25-8	6.60	8.30	25.00	25.0	25.0	150.00	22.00	6.00	40.0	7.6	25.0	SR M6X16 DIN912	HW 5.0
GHDR/L 3225-8	6.60	8.30	25.00	32.0	25.0	168.50	22.00	5.90	40.0	-	32.0	SR M6X16 DIN912	HW 5.0
GHDR/L 25-812	6.60	8.30	12.00	25.0	25.0	140.00	22.00	5.90	33.0	-	25.0	SR M6X16 DIN912	HW 5.0
GHDR/L 32-8	6.60	8.30	25.00	32.0	32.0	170.00	29.00	6.00	40.0	-	32.0	SR M6X16 DIN912	HW 5.0
GHDR/L 32-812	6.60	8.30	12.00	32.0	32.0	160.00	29.00	5.90	33.0	-	32.0	SR M6X16 DIN912	HW 5.0
GHDR/L 32-836	7.00	8.30	36.00	32.0	32.0	170.00	28.90	6.30	56.0	8.0	32.0	SR M8X20 DIN912	HW 6.0
GHDR/L 25-10	8.60	11.10	25.00	25.0	25.0	150.00	21.30	7.40	43.0	7.6	25.0	SR M8X20 DIN912	HW 6.0
GHDR/L 32-10	8.60	11.10	25.00	32.0	32.0	170.00	28.30	7.40	43.0	-	32.0	SR M8X20 DIN912	HW 6.0
GHDR/L 40-10	8.60	11.10	25.00	40.0	40.0	200.00	36.30	7.40	43.0	-	40.0	SR M8X20 DIN912	HW 6.0

• For user guide, see pages 380-395

⁽¹⁾ Minimum cutting width

⁽²⁾ Maximum cutting width

⁽³⁾ Cutting depth maximum

CUTGRIP JETCUT

GHDR/L-JHP (long pocket)

Grooving and Turning CUT-GRIP Tools with Channels for High Pressure Coolant

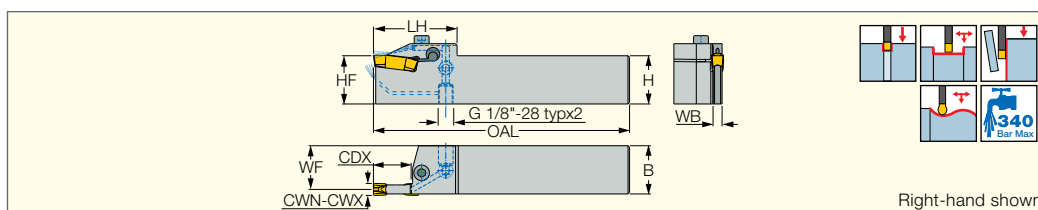

Designation	CWN ⁽¹⁾	CWX ⁽²⁾	CDX ⁽³⁾	H	B	OAL	LH	WF	WB	HF
GHDR/L 32-8-JHP	6.60	8.30	25.00	32.0	32.0	170.00	55.0	29.00	6.00	32.0

• For user guide and accessories see pages 380-400

⁽¹⁾ Minimum cutting width

⁽²⁾ Maximum cutting width

⁽³⁾ Cutting depth maximum

Flow Rate vs. Pressure

Designation	70 Bar Flow Rate (liters/min)	100 Bar Flow Rate (liters/min)	140 Bar Flow Rate (liters/min)
GHDR/L 32-8-JHP	13-16	19-21	22-24

Spare Parts

Designation			
GHDR/L 32-8-JHP	SR M6X25 DIN912	HW 5.0	PLUG G1/8ISO1179



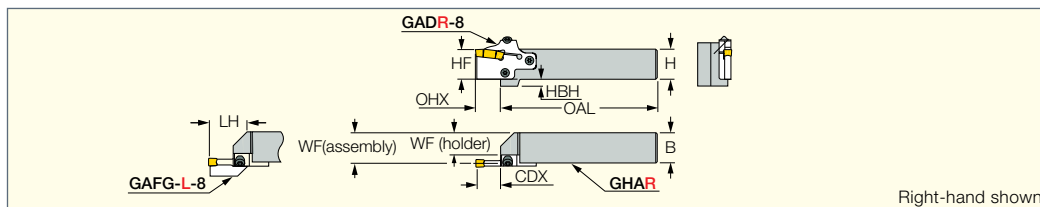

CUTGRIP

GHAR/L-8

External Holders for Grooving and Turning Adapters



Right-hand shown

Designation	H	HF	B	WF ⁽¹⁾	OAL	LH	OHX ⁽²⁾	HBH	TGA ⁽³⁾	CDX ⁽⁴⁾	FG ⁽⁵⁾				
GHAR/L 25-8	25.0	25.0	25.0	16.0	124.50	45.0	25.50	14.0	GADR/L 8	25.50	GAFG...R/L-8	SR 14-519	T-20/5	SR M6X25 DIN912	HW 5.0
GHAR/L 32-8	32.0	32.0	32.0	23.0	144.50	45.0	25.50	7.0	GADR/L 8	25.50	GAFG...R/L-8	SR 14-519	T-20/5	SR M6X25 DIN912	HW 5.0

• Adapters GADR/L-8 for turning and grooving, GAFG-R/L-8 for face-grooving (to be ordered separately)

⁽¹⁾ WF(holder)

⁽²⁾ Maximum overhang

⁽³⁾ Adapter for Turning & Grooving

⁽⁴⁾ See specific adapter dimensions

⁽⁵⁾ Adapter for Face Grooving



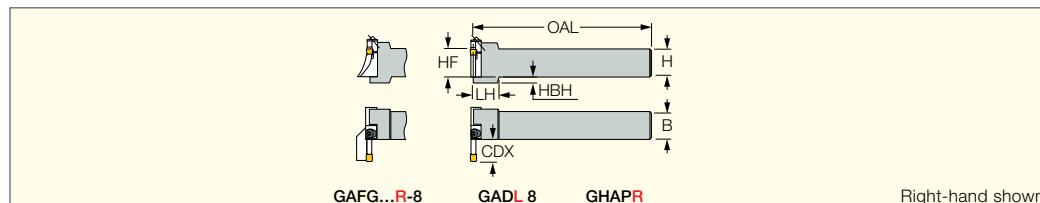

CUTGRIP

GHAPR/L-8

External Holders for Grooving and Turning Perpendicularly Oriented Adapters



Right-hand shown

Designation	H	HF	B	OAL	LH	HBH	TGA ⁽¹⁾	CDX ⁽²⁾	FG ⁽³⁾				
GHAPR/L 32-8	32.0	32.0	32.0	155.00	30.0	7.0	GADR/L 8	25.50	GAFG...R/L-8	SR 14-519	T-20/5	SR M6X25 DIN912	HW 5.0

• Adapters GADR/L-8 for turning and grooving, GAFG-R/L-8 for face-grooving (to be ordered separately)

⁽¹⁾ Adapter for Turning & Grooving

⁽²⁾ See specific adapter dimensions

⁽³⁾ Adapter for Face Grooving

CUTGRIP

GADR/L-8

Adapters for up to 25 mm Deep Machining

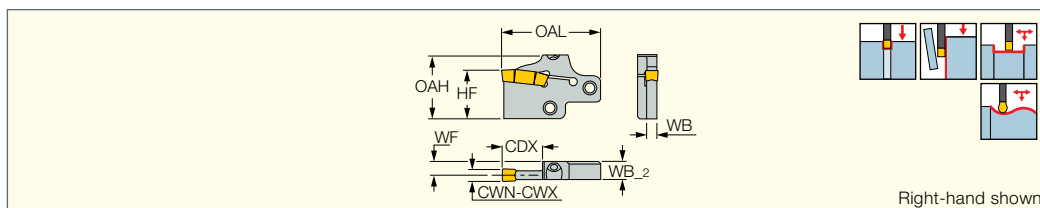

Right-hand shown

Designation	CWN ⁽¹⁾	CWX ⁽²⁾	CDX ⁽³⁾	WB	HF	OAH	OAL	WB_2	WF
GADR/L 8	6.60	8.30	25.50	6.00	32.0	42.0	63.00	12.0	9.00

• For user guide, see pages 380-395

⁽¹⁾ Minimum cutting width

⁽²⁾ Maximum cutting width

⁽³⁾ Cutting depth maximum

For inserts, see pages: GDMA (284) • GDMF (271) • GDMM-CC (565) • GDMN (273) • GDMU (273) • GDMY (272) • GDMY (full radius) (274) • GDMY-F (275) • GIA-K (long pocket) (282) • GIF-E (W=8,10 full radius) (277) • GIF-E (W=8,10) (276) • GIPA/GIDA 8 (full radius) (286)

For holders, see pages: C#-GHAD-8 (594) • C#-GHAPR/L-8 (594) • GHAPR/L-8 (269) • GHAR/L-8 (269) • IM-GHAD-8 (599) • IM-GHAPR/L-8 (600)

CUTGRIP JETCUT

GHAR/L-JHP

Holders with High Pressure Coolant Channels for Grooving and Turning Adapters

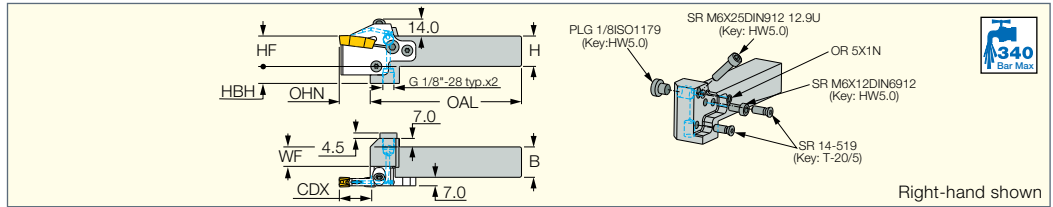

Right-hand shown

Designation	H	HF	B	WF	OAL	OHN ⁽¹⁾	HBH	CDX ⁽²⁾
GHAR/L 25-8-JHP	25.0	25.0	25.0	16.0	124.50	25.00	14.0	25.50

• For user guide and accessories see pages 380-400

⁽¹⁾ Minimum overhang

⁽²⁾ See specific adapter dimensions

Spare Parts

Designation							
GHAR/L-JHP	SR 14-519	T-20/5	OR 5X1N	SR M6X12DIN6912	SR M6X25 DIN912	PLUG G1/8ISO1179	HW 5.0X120 MM

CUTGRIP JETCUT

GADR/L-JHP

Adapters for up to 25 mm Deep Machining with High Pressure Coolant Channels Carrying Groove-Turn Inserts

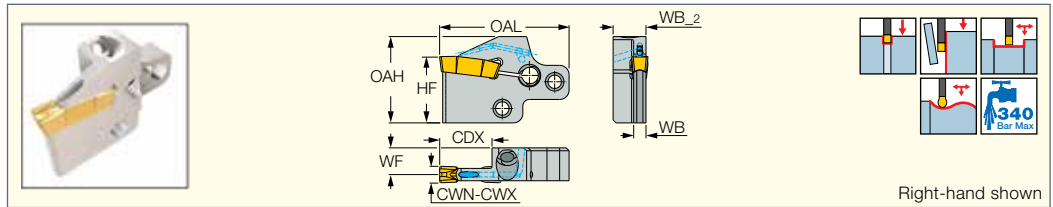

Right-hand shown

Designation	CWN ⁽¹⁾	CWX ⁽²⁾	CDX ⁽³⁾	WB	HF	OAH	OAL	WB_2	WF
GADR/L 8-JHP	6.60	8.30	25.50	6.00	32.0	42.0	63.00	17.0	14.00
GADR/L 10-JHP	8.60	10.30	25.50	7.40	32.0	42.0	63.00	17.7	14.00

• For user guide and accessories see pages 380-400

⁽¹⁾ Minimum cutting width

⁽²⁾ Maximum cutting width

⁽³⁾ Cutting depth maximum

For inserts, see pages: GDMA (284) • GDMF (271) • GDMM-CC (565) • GDMN (273) • GDMU (273) • GDMY (272) • GDMY (full radius) (274) • GDMY-F (275) • GDPY (277) • GIA-K (long pocket) (282) • GIF (long pocket) (281) • GIF-E (W=8,10 full radius) (277) • GIF-E (W=8,10) (276) • GIPA/GIDA 8 (full radius) (286)

Flow Rate vs. Pressure

Designation	70 Bar Flow Rate (liters/min)	100 Bar Flow Rate (liters/min)	140 Bar Flow Rate (liters/min)
GADR/L-JHP	15-17	23-25	27-29

CUTGRIP

CGHN-8-10D

Heavy Duty Deep Grooving and Turning Blades

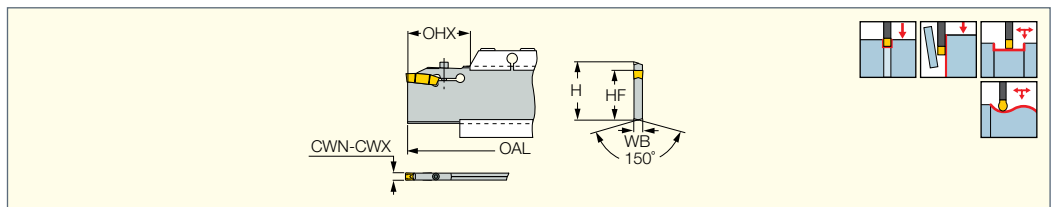

Designation	CWN ⁽¹⁾	CWX ⁽²⁾	OHX ⁽³⁾	WB	HF	H	OAL		
CGHN 52-8D	8.00	8.30	50.0	7.40	45.0	52.6	190.00	SR 76-1637	HW 4.0
CGHN 53-8D	8.00	8.30	70.0	7.40	45.0	52.6	260.00	SR 76-1637	HW 4.0
CGHN 52-10D	10.00	11.00	70.0	9.20	45.0	52.6	190.00	SR 76-1289	HW 5.0
CGHN 53-10D	10.00	11.00	100.0	9.20	45.0	52.6	260.00	SR 76-1289	HW 5.0

• For user guide, see pages 380-395

⁽¹⁾ Minimum cutting width

⁽²⁾ Maximum cutting width

⁽³⁾ Minimum overhang • When using a double-ended insert, grooving depth is limited by the insert

For inserts, see pages: GDMF (271) • GDMN (273) • GDMU (273) • GDMY (272) • GDMY (full radius) (274) • GDMY-F (275) • GDPY (277) • GIA-K (long pocket) (282) • GIF (long pocket) (281) • GIF-E (W=8,10 full radius) (277) • GIF-E (W=8,10) (276) • GIPA/GIDA 8 (full radius) (286)

For holders, see pages: SGTBK (587) • SGTBU/SGTBN (586)

CUTGRIP

GIMT
Utility Single-Ended Inserts
for Grooving and Turning

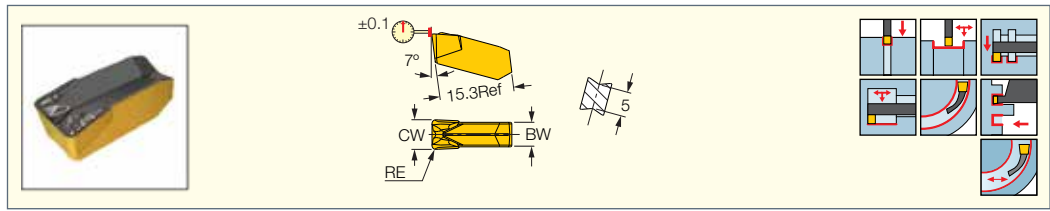

Designation	Dimensions					Tough ↔ Hard				Recommended Machining Data		
	CW	RE	CWTOL ⁽¹⁾	RETOL ⁽²⁾	BW	IC830	IC808	IC07	IC806	a _p (mm)	f turn (mm/rev)	f groove (mm/rev)
GIMT 304	3.00	0.40	0.05	0.050	2.40	●	●	●	●	0.50-1.80	0.10-0.22	0.07-0.15
GIMT 404	4.00	0.40	0.05	0.050	3.40	●	●	●	●	0.50-2.40	0.15-0.25	0.09-0.20
GIMT 508	5.00	0.80	0.05	0.050	4.00	●	●	●	●	1.00-3.00	0.20-0.35	0.11-0.22
GIMT 608	6.00	0.80	0.05	0.050	5.00	●	●	●	●	1.00-3.60	0.22-0.40	0.13-0.25

• DMIN for internal applications = 70 mm • For cutting speed recommendations and user guide, see pages 380-395

⁽¹⁾ Cutting width tolerance (+/-)

⁽²⁾ Corner radius tolerance (+/-)

For tools, see pages: Anti-Vibration Blades (268) • C#-GHDR/L (259) • CGHN 26-M (340) • CGHN 32-DGM (342) • CGHN 32-M (341) • CGHN-D (266) • CGHN-DG (267) • CGHN-S (266) • CGPAD (265) • CGPAD-JHP (265) • GHDR/L (short pocket) (259) • GHDR/L-JHP (short pocket) (260) • GHDR/L-JHP-MC (short pocket) (261) • GHGR/L (262) • GHMPRL (258) • GHMR/L (258)

CUTGRIP

GIMF
Utility Single-Ended Inserts
for Grooving and Turning

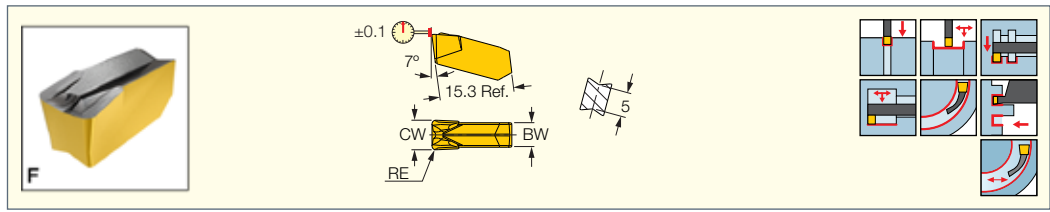

Designation	Dimensions					Tough ↔ Hard										Recommended Machining Data					
	CW	RE	CWTOL ⁽¹⁾	RETOL ⁽²⁾	BW	IC830	IC1030	IC8250	IC1010	IC808	IC908	IC20	IC5010	IC428	IC806	IC907	IC4	IC804	a _p (mm)	f turn (mm/rev)	f groove (mm/rev)
GIMF 406	4.00	0.60	0.05	0.050	3.40	●				●	●	●	●	●	●	●	●	●	0.75-2.40	0.19-0.25	0.09-0.16
GIMF 502	5.00	0.20	0.05	0.050	4.00			●											0.25-3.00	0.18-0.26	0.11-0.18
GIMF 508	5.00	0.80	0.05	0.050	4.00	●				●	●	●	●	●	●	●	●	●	1.00-3.00	0.23-0.35	0.11-0.21
GIMF 605	6.00	0.50	0.05	0.050	5.00	●				●	●	●	●	●	●	●	●	●	0.60-3.60	0.22-0.36	0.13-0.23
GIMF 608	6.00	0.80	0.05	0.050	5.00	●	●	●	●	●	●	●	●	●	●	●	●	●	1.00-3.60	0.24-0.42	0.13-0.25
GIMF 808	8.00	0.80	0.05	0.050	6.00	●		●		●	●	●	●	●	●	●	●	●	1.00-4.80	0.32-0.56	0.18-0.34

• DMIN for internal applications = 70 mm • For cutting speed recommendations and user guide, see pages 380-395

⁽¹⁾ Cutting width tolerance (+/-)

⁽²⁾ Corner radius tolerance (+/-)

For tools, see pages: Anti-Vibration Blades (268) • C#-GHDR/L (259) • CGFG 51-P8 (563) • CGHN 26-M (340) • CGHN 32-DGM (342) • CGHN 32-M (341) • CGHN-D (266) • CGHN-DG (267) • CGHN-P8 (267) • CGHN-S (266) • CGHR/L-P8DG (267) • CGPAD (265) • CGPAD-JHP (265) • GHDR/L (short pocket) (259) • GHDR/L-JHP (short pocket) (260) • GHDR/L-JHP-MC (short pocket) (261) • GHGR/L (262) • GHMPRL (258) • GHMR/L (258)

CUTGRIP

GDMF
Utility Double-Ended Inserts
for Grooving and Turning

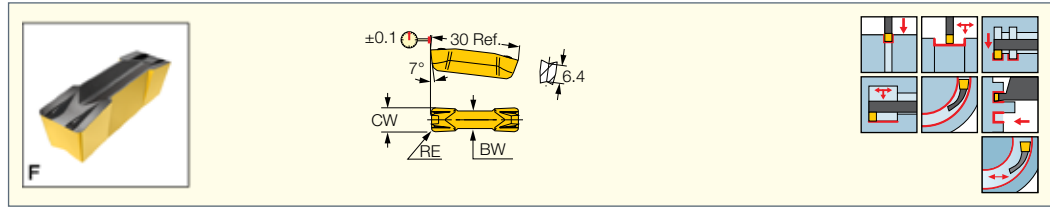

Designation	Dimensions						Tough ↔ Hard					Recommended Machining Data		
	CW	RE	CWTOL ⁽¹⁾	RETOL ⁽²⁾	CDX	BW	IC830	IC8250	IC808	IC5010	IC428	a _p (mm)	f turn (mm/rev)	f groove (mm/rev)
GDMF 808	8.00	0.80	0.05	0.050	27.00	6.00	●	●	●	●	●	1.00-4.80	0.32-0.56	0.18-0.34

• DMIN for internal machining = 65 mm • For cutting speed recommendations and user guide, see pages 380-395

⁽¹⁾ Cutting width tolerance (+/-)

⁽²⁾ Corner radius tolerance (+/-)

For tools, see pages: C#-GHDR/L (259) • CGHN-8-10D (270) • GADR/L-8 (269) • GADR/L-JHP (270) • GAFG-R/L-8 (562) • GHDR/L (long pocket) (268) • GHDR/L-JHP (long pocket) (268) • GHFG-R/L-8 (561) • GHFGR/L-8 (561) • GHIR/L (W=7.0-8.3) (339)

CUTGRIP

GIMY

Utility Single-Ended Inserts for Grooving and Turning

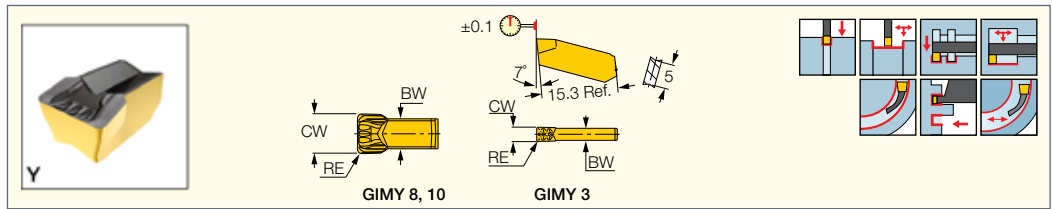

Designation	Dimensions					Tough ↔ Hard								Recommended Machining Data		
	CW	RE	CWTOL ⁽¹⁾	RETOL ⁽²⁾	BW	IC830	IC8250	IC808	IC908	IC20	IC806	IC4	IC804	a _p (mm)	f turn (mm/rev)	f groove (mm/rev)
GIMY 304	3.00	0.40	0.05	0.050	2.40	●	●			●	●	●	●	0.50-1.80	0.16-0.20	0.07-0.12
GIMY 808	8.00	0.80	0.05	0.050	6.00	●	●	●	●	●	●			1.00-4.80	0.32-0.56	0.18-0.34
GIMY 1008	10.00	0.80	0.05	0.050	8.00	●		●						1.00-6.00	0.35-0.65	0.22-0.40

• DMIN for internal applications = 70 mm • For cutting speed recommendations and user guide, see pages 380-395

⁽¹⁾ Cutting width tolerance (+/-)

⁽²⁾ Corner radius tolerance (+/-)

For tools, see pages: Anti-Vibration Blades (268) • C#-GHDR/L (259) • CGFG 51-P8 (563) • CGHN 26-M (340) • CGHN 32-DGM (342) • CGHN 32-M (341) • CGHN-D (266) • CGHN-DG (267) • CGHN-P8 (267) • CGHN-S (266) • CGHR/L-P8DG (267) • CGPAD (265) • CGPAD-JHP (265) • GHDR/L (short pocket) (259) • GHDR/L-JHP (short pocket) (260) • GHDR/L-JHP-MC (short pocket) (261) • GHGR/L (262) • GHMPR/L (258) • GHMR/L (258) • GHSR/L (357) • GHSR/L-JHP-SL (358)

CUTGRIP

GDMY

Utility Double-Ended Inserts for Grooving and Turning

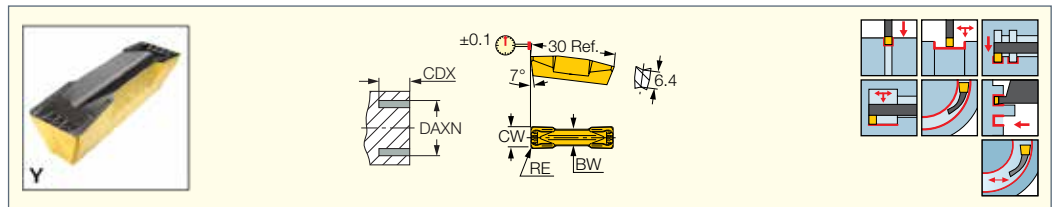

Designation	Dimensions						Tough ↔ Hard						Recommended Machining Data			
	CW	RE	CWTOL ⁽¹⁾	RETOL ⁽²⁾	BW	DAXN ⁽³⁾	CDX	IC830	IC8250	IC808	IC20	IC5010	IC428	a _p (mm)	f turn (mm/rev)	f groove (mm/rev)
GDMY 808	8.00	0.80	0.05	0.050	6.00	50.0	27.00	●	●	●	●	●	●	1.00-4.80	0.32-0.56	0.18-0.34

• DMIN for internal machining = 65 mm • For cutting speed recommendations and user guide, see pages 380-395

⁽¹⁾ Cutting width tolerance (+/-)

⁽²⁾ Corner radius tolerance (+/-)

⁽³⁾ Minimum axial grooving diameter

For tools, see pages: C#-GHDR/L (259) • CGHN-8-10D (270) • GADR/L-8 (269) • GADR/L-JHP (270) • GAFG-R/L-8 (562) • GHDR/L (long pocket) (268) • GHDR/L-JHP (long pocket) (268) • GHFG-R/L-8 (561) • GHFGR/L-8 (561) • GHIR/L (W=7.0-8.3) (339)

CUTGRIP

GIMN

Utility Single-Ended Inserts for Grooving and Turning Ductile Materials

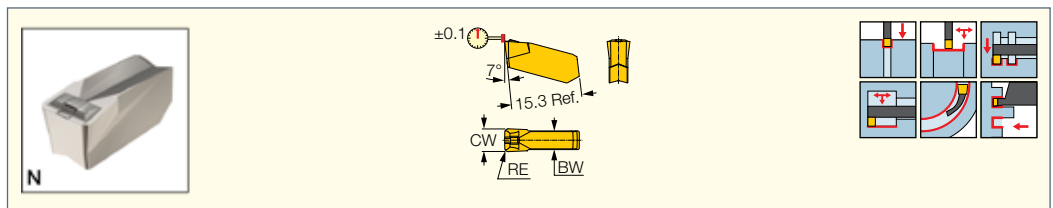

Designation	Dimensions					Tough ↔ Hard		Recommended Machining Data		
	CW	RE	CWTOL ⁽¹⁾	RETOL ⁽²⁾	BW	IC908	IC907	a _p (mm)	f turn (mm/rev)	f groove (mm/rev)
GIMN 302	3.00	0.20	0.05	0.050	2.40		●	0.30-1.20	0.07-0.11	0.04-0.09
GIMN 406	4.00	0.60	0.05	0.050	3.40		●	0.75-1.60	0.11-0.18	0.05-0.14
GIMN 508	5.00	0.80	0.05	0.050	4.10	●	●	1.00-2.00	0.15-0.25	0.06-0.18
GIMN 608	6.00	0.80	0.05	0.050	5.00		●	1.00-2.40	0.18-0.30	0.07-0.22

• DMIN for internal applications = 70 mm • For cutting speed recommendations and user guide, see pages 380-395

⁽¹⁾ Cutting width tolerance (+/-)

⁽²⁾ Corner radius tolerance (+/-)

For tools, see pages: Anti-Vibration Blades (268) • C#-GHDR/L (259) • CGHN 26-M (340) • CGHN 32-DGM (342) • CGHN 32-M (341) • CGHN-D (266) • CGHN-DG (267) • CGHN-S (266) • CGPAD (265) • CGPAD-JHP (265) • GHDR/L (short pocket) (259) • GHDR/L-JHP (short pocket) (260) • GHDR/L-JHP-MC (short pocket) (261) • GHGR/L (262) • GHMPR/L (258) • GHMR/L (258)

CUTGRIP

GDMN

Utility Double-Ended Inserts, for Grooving and Turning Ductile Materials

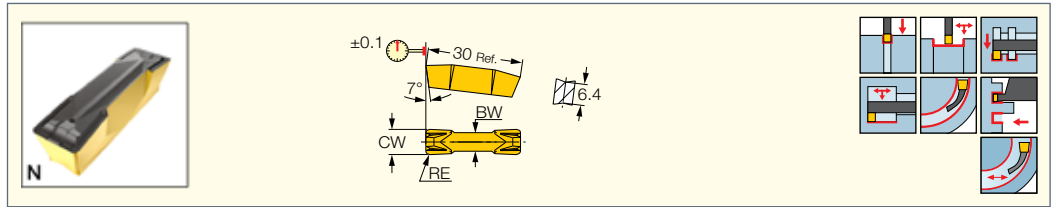

Designation	Dimensions						Tough ↔ Hard				Recommended Machining Data		
	CW	RE	CWTOL ⁽¹⁾	RETOL ⁽²⁾	CDX	BW	IC830	IC8250	IC808	IC907	a _p (mm)	f turn (mm/rev)	f groove (mm/rev)
GDMN 808	8.00	0.80	0.05	0.050	27.00	6.00	●	●	●	●	1.00-3.20	0.20-0.35	0.10-0.30

• DMIN for internal machining = 65 mm • For cutting speed recommendations and user guide, see pages 380-395

⁽¹⁾ Cutting width tolerance (+/-)

⁽²⁾ Corner radius tolerance (+/-)

For tools, see pages: C#-GHDR/L (259) • CGHN-8-10D (270) • GADR/L-8 (269) • GADR/L-JHP (270) • GAFG-R/L-8 (562) • GHDR/L (long pocket) (268) • GHDR/L-JHP (long pocket) (268) • GHFG-R/L-8 (561) • GHFGR/L-8 (561) • GHIR/L (W=7.0-8.3) (339)

CUTGRIP

GDMU

Utility Inserts for Heavy Grooving on Ductile Materials

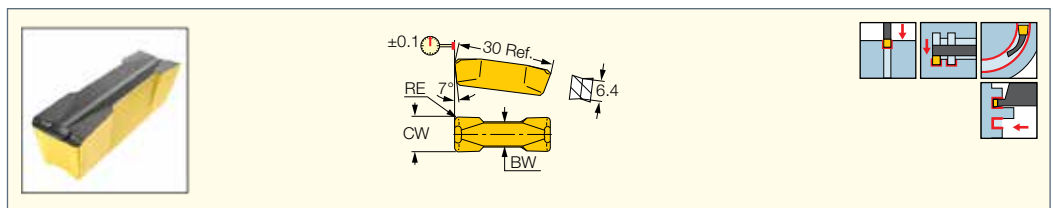

Designation	Dimensions					Tough ↔ Hard		Recommended Machining Data
	CW	RE	CWTOL ⁽¹⁾	RETOL ⁽²⁾	BW	IC830	IC8250	f groove (mm/rev)
GDMU 808	8.00	0.80	0.05	0.050	6.00	●	●	0.10-0.24

• For cutting speed recommendations and user guide, see pages 380-395

⁽¹⁾ Cutting width tolerance (+/-)

⁽²⁾ Corner radius tolerance (+/-)

For tools, see pages: C#-GHDR/L (259) • CGHN-8-10D (270) • GADR/L-8 (269) • GADR/L-JHP (270) • GAFG-R/L-8 (562) • GHDR/L (long pocket) (268) • GHDR/L-JHP (long pocket) (268) • GHFG-R/L-8 (561) • GHFGR/L-8 (561) • GHIR/L (W=7.0-8.3) (339)

CUTGRIP

GIMY (full radius)

Utility Single-Ended Inserts for Grooving and Profiling

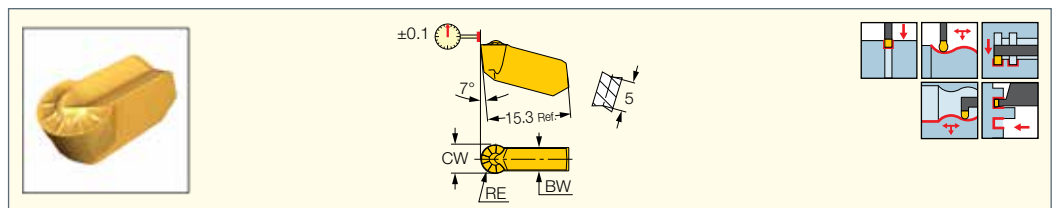

Designation	Dimensions					Tough ↔ Hard								Recommended Machining Data		
	CW	RE	CWTOL ⁽¹⁾	RETOL ⁽²⁾	BW	IC830	IC8250	IC808	IC908	IC20	IC20N	IC806	IC804	a _p (mm)	f turn (mm/rev)	f groove (mm/rev)
GIMY 315	3.00	1.50	0.05	0.050	2.40	●	●	●	●	●	●	●	●	0.00-1.50	0.18-0.26	0.07-0.13
GIMY 420	4.00	2.00	0.05	0.050	3.20	●	●	●	●	●	●	●	●	0.00-2.00	0.20-0.28	0.09-0.17
GIMY 525	5.00	2.50	0.05	0.050	3.90	●	●	●	●	●	●	●	●	0.00-2.50	0.23-0.42	0.11-0.21
GIMY 630	6.00	3.00	0.05	0.050	5.00	●	●	●	●	●	●	●	●	0.00-3.00	0.24-0.50	0.13-0.25
GIMY 635-318	6.35	3.18	0.05	0.050	5.10	●	●	●	●	●	●	●	●	0.00-3.10	0.25-0.53	0.14-0.27
GIMY 840	8.00	4.00	0.05	0.050	5.60	●	●	●	●	●	●	●	●	0.00-4.00	0.32-0.67	0.18-0.34

• DMIN for internal application=70 mm • Can cut arcs to 250° • For cutting speed recommendations and user guide, see pages 380-395

⁽¹⁾ Cutting width tolerance (+/-)

⁽²⁾ Corner radius tolerance (+/-)

For tools, see pages: Anti-Vibration Blades (268) • C#-GHDR/L (259) • CGFG 51-P8 (563) • CGHN 26-M (340) • CGHN 32-DGM (342) • CGHN 32-M (341) • CGHN-D (266) • CGHN-DG (267) • CGHN-P8 (267) • CGHN-S (266) • CGHR/L-P8DG (267) • CGPAD (265) • CGPAD-JHP (265) • GHDR/L (short pocket) (259) • GHDR/L-JHP (short pocket) (260) • GHDR/L-JHP-MC (short pocket) (261) • GHGR/L (262) • GHMPR/L (258) • GHMR/L (258) • GHSR/L (357) • GHSR/L-JHP-SL (358)

CUTGRIP

GIMY 1260

Utility Single-Ended Inserts for External Grooving and Profiling

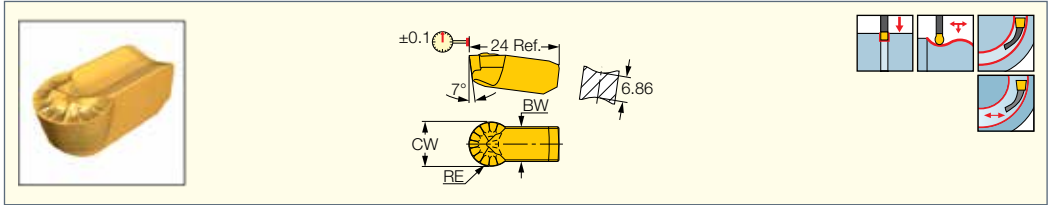

Designation	Dimensions					Tough ↔ Hard					Recommended Machining Data		
	CW	RE	CWTOL ⁽¹⁾	RETOL ⁽²⁾	BW	IC830	IC8250	IC808	IC908	IC20	a _p (mm)	f turn (mm/rev)	f groove (mm/rev)
GIMY 1260	12.00	6.00	0.05	0.050	9.50	●	●	●	●	●	0.00-6.00	0.42-0.86	0.26-0.45

• Toolholder seat needs to be modified according to insert profile to ensure clearance • For cutting speed recommendations and user guide, see pages 380-395

⁽¹⁾ Cutting width tolerance (+/-)
⁽²⁾ Corner radius tolerance (+/-)

For tools, see pages: CGHR/L-12-14D (319) • GHDR/L/N 12/14 (319)

CUTGRIP

GDMY (full radius)

Utility Double-Ended Full Radius Inserts for Grooving and Profiling

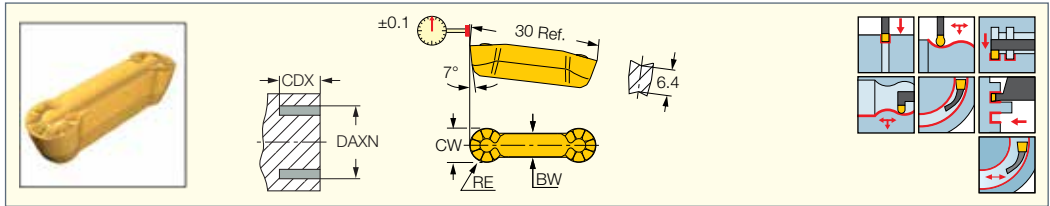

Designation	Dimensions							Tough ↔ Hard						Recommended Machining Data			
	CW	RE	CWTOL ⁽¹⁾	RETOL ⁽²⁾	BW	DAXN ⁽³⁾	CDX	IC830	IC8250	IC808	IC20	IC5010	IC428	IC806	a _p (mm)	f turn (mm/rev)	f groove (mm/rev)
GDMY 840	8.00	4.00	0.05	0.050	5.60	50.0	25.00	●	●	●	●	●	●	●	0.00-4.00	0.32-0.67	0.18-0.34

• Can cut arcs to 250° • DMIN for internal machining = 65 mm • For cutting speed recommendations and user guide, see pages 380-395

⁽¹⁾ Cutting width tolerance (+/-)
⁽²⁾ Corner radius tolerance (+/-)
⁽³⁾ Minimum axial grooving diameter

For tools, see pages: C#-GHDR/L (259) • CGHN-8-10D (270) • GADR/L-8 (269) • GADR/L-JHP (270) • GAFG-R/L-8 (562) • GHDKR/L (407) • GHDR/L (long pocket) (268) • GHDR/L-JHP (long pocket) (268) • GHFG-R/L-8 (561) • GHFGR/L-8 (561) • GHIR/L (W=7.0-8.3) (339)

CUTGRIP

GIMY-F

Utility Single-Ended Inserts for Grooving and Profiling Ductile Materials

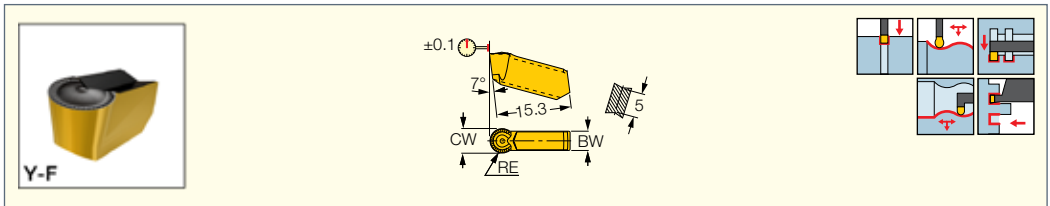

Designation	Dimensions					Tough ↔ Hard					Recommended Machining Data		
	CW	RE	CWTOL ⁽¹⁾	RETOL ⁽²⁾	BW	IC8250	IC808	IC908	IC806	IC804	a _p (mm)	f turn (mm/rev)	f groove (mm/rev)
GIMY 315F	3.00	1.50	0.00	0.050	2.40		●				0.00-1.50	0.18-0.26	0.07-0.13
GIMY 525F	5.00	2.50	0.00	0.050	3.90		●		●		0.00-2.50	0.23-0.42	0.11-0.21
GIMY 630F	6.00	3.00	0.00	0.050	5.00		●	●	●	●	0.00-3.00	0.24-0.50	0.13-0.25
GIMY 840F	8.00	4.00	0.05	0.050	5.60	●					0.00-4.00	0.32-0.67	0.18-0.34

• DMIN for internal applications = 70 mm • Can cut arcs to 250° • For cutting speed recommendations and user guide, see pages 380-395

⁽¹⁾ Cutting width tolerance (+/-)
⁽²⁾ Corner radius tolerance (+/-)

For tools, see pages: Anti-Vibration Blades (268) • C#-GHDR/L (259) • CGFG 51-P8 (563) • CGHN 26-M (340) • CGHN 32-DGM (342) • CGHN 32-M (341) • CGHN-D (266) • CGHN-DG (267) • CGHN-P8 (267) • CGHN-S (266) • CGHR/L-P8DG (267) • CGPAD (265) • CGPAD-JHP (265) • GHDR/L (short pocket) (259) • GHDR/L-JHP (short pocket) (260) • GHDR/L-JHP-MC (short pocket) (261) • GHGR/L (262) • GHMPR/L (258) • GHMR/L (258) • GHSLR/L (357) • GHSLR/L-JHP-SL (358)

CUTGRIP

GDMY-F

Utility Double-Ended Inserts for Grooving and Profiling Ductile Materials

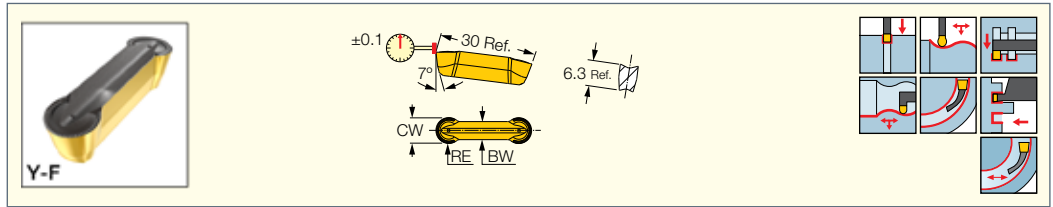

Designation	Dimensions						Tough ↔ Hard		Recommended Machining Data		
	CW	RE	CWTOL ⁽¹⁾	RETOL ⁽²⁾	BW	CDX	IC808	IC908	a _p (mm)	f turn (mm/rev)	f groove (mm/rev)
GDMY 840F	8.00	4.00	0.05	0.050	5.60	25.00	●	●	0.00-4.00	0.32-0.67	0.18-0.34

• DMIN for internal applications = 65 mm • For cutting speed recommendations and user guide, see pages 380-395

⁽¹⁾ Cutting width tolerance (+/-)

⁽²⁾ Corner radius tolerance (+/-)

For tools, see pages: C#-GHDR/L (259) • CGHN-8-10D (270) • GADR/L-8 (269) • GADR/L-JHP (270) • GAFG-R/L-8 (562) • GHDR/L (long pocket) (268) • GHDR/L-JHP (long pocket) (268) • GHFG-R/L-8 (561) • GHFGR/L-8 (561) • GHIR/L (W=7.0-8.3) (339)

CUTGRIP

GIF-E (W=4-6)

Precision Double-Ended Inserts for Grooving and Turning

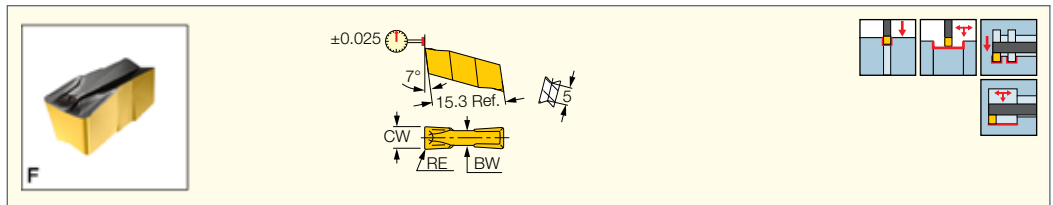

Designation	Dimensions						Tough ↔ Hard					Recommended Machining Data		
	CW	RE	CWTOL ⁽¹⁾	RETOL ⁽²⁾	BW	CDX	IC830	IC8250	IC808	IC20	IC807	a _p (mm)	f turn (mm/rev)	f groove (mm/rev)
GIF 4.00E-0.40	4.00	0.40	0.02	0.030	3.20	13.00	●	●	●	●	●	0.50-2.40	0.18-0.24	0.09-0.15
GIF 4.00E-0.60	4.00	0.60	0.02	0.050	3.20	13.00	●	●	●	●	●	0.75-2.40	0.19-0.25	0.09-0.16
GIF 4.00E-0.80	4.00	0.80	0.02	0.050	3.20	13.00	●	●	●	●	●	1.00-2.40	0.20-0.28	0.09-0.17
GIF 5.00E-0.40	5.00	0.40	0.02	0.030	4.00	13.00	●	●	●	●	●	0.50-3.00	0.20-0.30	0.11-0.19
GIF 5.00E-0.60	5.00	0.60	0.02	0.050	4.00	13.00	●	●	●	●	●	0.75-3.00	0.21-0.32	0.11-0.20
GIF 5.00E-0.80	5.00	0.80	0.02	0.050	4.00	13.00	●	●	●	●	●	1.00-3.00	0.23-0.35	0.11-0.21
GIF 6.00E-0.40	6.00	0.40	0.02	0.030	4.80	13.00	●	●	●	●	●	0.50-3.60	0.22-0.36	0.13-0.23
GIF 6.00E-0.80	6.00	0.80	0.02	0.050	4.80	13.00	●	●	●	●	●	1.00-3.60	0.24-0.42	0.13-0.25
GIF 6.00E-1.20	6.00	1.20	0.02	0.050	4.80	13.00	●	●	●	●	●	1.45-3.60	0.24-0.46	0.13-0.25

• DMIN for internal machining = 70 mm • For cutting speed recommendations and user guide, see pages 380-395

⁽¹⁾ Cutting width tolerance (+/-)

⁽²⁾ Corner radius tolerance (+/-)

For tools, see pages: Anti-Vibration Blades (268) • C#-GHDR/L (259) • CGHN 26-M (340) • CGHN 32-DGM (342) • CGHN 32-M (341) • CGHN-D (266) • CGHN-DG (267) • CGHN-S (266) • CGPAD (265) • CGPAD-JHP (265) • GHDR/L (short pocket) (259) • GHDR/L-JHP (short pocket) (260) • GHDR/L-JHP-MC (short pocket) (261) • GHGR/L (262) • GHMPR/L (258) • GHMR/L (258)

CUTGRIP

GIF-E (W=8,10)

Precision Double-Ended Inserts for Grooving and Turning

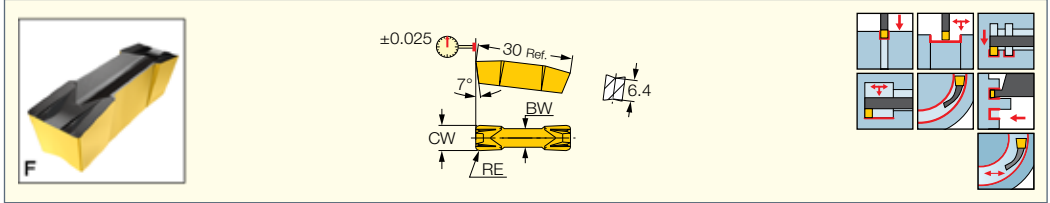

Designation	Dimensions						Tough ↔ Hard								Recommended Machining Data		
	CW	RE	CWTOL ⁽¹⁾	RETOL ⁽²⁾	BW	CDX	IC830	IC8250	IC808	IC20	IC5010	IC428	IC806	IC807	a _p (mm)	f turn (mm/rev)	f groove (mm/rev)
GIF 8.00E-0.40	8.00	0.40	0.02	0.030	6.00	27.00	●	●	●						0.50-4.80	0.29-0.48	0.18-0.31
GIF 8.00E-0.80	8.00	0.80	0.02	0.050	6.00	27.00	●	●	●	●	●	●	●	●	1.00-4.80	0.32-0.56	0.18-0.34
GIF 8.00E-1.20	8.00	1.20	0.02	0.050	6.00	27.00	●	●	●	●	●	●	●	●	1.45-4.80	0.32-0.62	0.18-0.34
GIF 10.00E-0.80	10.00	0.80	0.02	0.050	8.00	27.00	●	●	●	●	●	●	●	●	1.00-6.00	0.35-0.65	0.22-0.40
GIF 10.00E-1.20	10.00	1.20	0.02	0.050	8.00	27.00	●	●	●	●	●	●	●	●	1.45-6.00	0.35-0.72	0.22-0.40

• DMIN for internal machining = 65 mm • For cutting speed recommendations and user guide, see pages 380-395

⁽¹⁾ Cutting width tolerance (+/-)

⁽²⁾ Corner radius tolerance (+/-)

For tools, see pages: C#-GHDR/L (259) • CGHN-8-10D (270) • GADR/L-8 (269) • GADR/L-JHP (270) • GAFG-R/L-8 (562) • GHDR/L (long pocket) (268) • GHDR/L-JHP (long pocket) (268) • GHFG-R/L-8 (561) • GHFGR/L-8 (561) • GHIR/L (W=7.0-8.3) (339)

CUTGRIP

GIP-E

Precision Double-Ended Inserts for Grooving and Turning

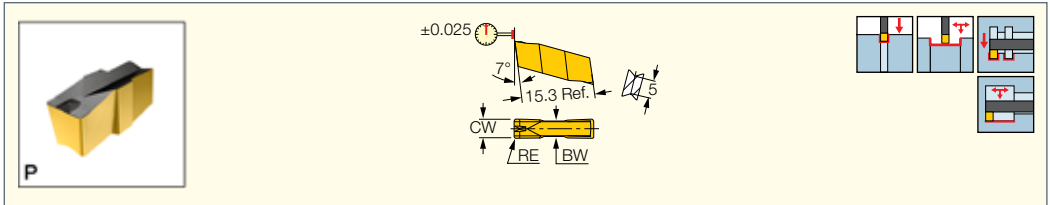

Designation	Dimensions						Tough ↔ Hard										Recommended Machining Data			
	CW	RE	CWTOL ⁽¹⁾	RETOL ⁽²⁾	BW	CDX	IC830	IC8250	IC808	IC908	IC20	IC20N	IC5010	IC428	IC806	IC807	IC804	a _p (mm)	f turn (mm/rev)	f groove (mm/rev)
GIP 3.00E-0.00	3.00	0.00	0.02	0.030	2.40	13.00	●											0.00-1.80	0.12-0.16	0.07-0.11
GIP 3.00E-0.20	3.00	0.20	0.02	0.030	2.40	13.00	●	●			●							0.25-1.80	0.15-0.20	0.08-0.13
GIP 3.00E-0.40	3.00	0.40	0.02	0.030	2.40	13.00	●	●	●	●	●	●	●	●	●	●	●	0.50-1.80	0.17-0.22	0.08-0.14
GIP 3.00E-0.80	3.00	0.80	0.02	0.050	2.40	13.00	●	●										1.00-1.80	0.19-0.26	0.08-0.15
GIP 4.00E-0.40	4.00	0.40	0.02	0.030	3.20	13.00	●	●	●		●	●	●	●	●	●	●	0.50-2.40	0.19-0.26	0.10-0.18
GIP 4.00E-0.60	4.00	0.60	0.02	0.050	3.20	13.00	●	●	●	●		●	●	●	●	●	●	0.75-2.40	0.21-0.28	0.10-0.19
GIP 4.00E-0.80	4.00	0.80	0.02	0.050	3.20	13.00	●	●	●	●		●	●	●	●	●	●	1.00-2.40	0.22-0.31	0.10-0.20
GIP 4.78E-0.55	4.78	0.55	0.02	0.050	4.00	13.00	●	●	●	●		●	●					0.70-2.80	0.21-0.31	0.12-0.20
GIP 5.00E-0.40	5.00	0.40	0.02	0.030	4.00	13.00	●	●	●	●					●			0.50-3.00	0.22-0.33	0.13-0.21
GIP 5.00E-0.60	5.00	0.60	0.02	0.050	4.00	13.00	●	●	●	●	●							0.75-3.00	0.23-0.35	0.13-0.22
GIP 5.00E-0.80	5.00	0.80	0.02	0.050	4.00	13.00	●	●	●	●		●	●					1.00-3.00	0.24-0.39	0.13-0.23
GIP 5.55E-0.55	5.55	0.55	0.02	0.050	4.80	13.00		●										0.70-3.30	0.21-0.36	0.14-0.23
GIP 6.00E-0.80	6.00	0.80	0.02	0.050	4.80	13.00		●				●	●					1.00-3.60	0.26-0.46	0.15-0.27
GIP 6.00E-1.20	6.00	1.20	0.02	0.050	4.80	13.00		●		●								1.45-3.60	0.26-0.51	0.15-0.27
GIP 6.35E-0.80	6.35	0.80	0.02	0.050	4.80	13.00	●	●	●	●								1.00-3.80	0.27-0.49	0.16-0.29

• DMIN for internal machining = 70 mm • For cutting speed recommendations and user guide, see pages 380-395

⁽¹⁾ Cutting width tolerance (+/-)

⁽²⁾ Corner radius tolerance (+/-)

For tools, see pages: Anti-Vibration Blades (268) • C#-GHDR/L (259) • CGHN 26-M (340) • CGHN 32-DGM (342) • CGHN 32-M (341) • CGHN-D (266) • CGHN-DG (267) • CGHN-S (266) • CGPAD (265) • CGPAD-JHP (265) • GHDR/L (short pocket) (259) • GHDR/L-JHP (short pocket) (260) • GHDR/L-JHP-MC (short pocket) (261) • GHGR/L (262) • GHMPR/L (258) • GHMR/L (258) • GHSR/L (357) • GHSR/L-JHP-SL (358)

CUTGRIP

GDPY

Precision Double-Ended Inserts for External Heavy-Duty Grooving and Turning

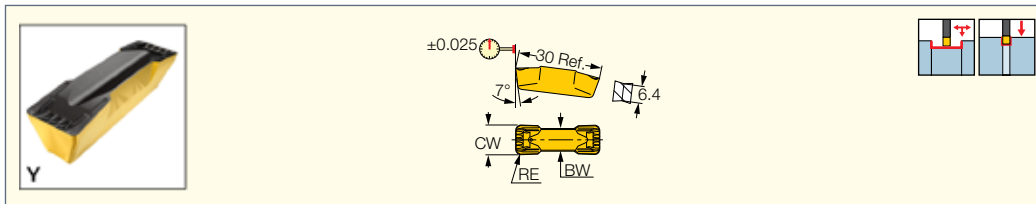

Designation	Dimensions					Tough ↔ Hard			Recommended Machining Data		
	CW	RE	CWTOL ⁽¹⁾	RETOL ⁽²⁾	BW	IC830	IC8250	IC20	a _p (mm)	f turn (mm/rev)	f groove (mm/rev)
GDPY 10.00-0.80	10.00	0.80	0.02	0.050	8.00	●	●	●	1.00-6.00	0.35-0.65	0.22-0.40
GDPY 10.00-1.20	10.00	1.20	0.02	0.050	8.00	●			1.45-6.00	0.45-0.80	0.22-0.40
GDPY 10.00-2.00	10.00	2.00	0.02	0.050	8.00	●		●	2.40-6.00	0.35-0.78	0.22-0.40
GDPY 11.00-1.20	11.00	1.20	0.02	0.050	8.00	●			1.45-6.60	0.39-0.73	0.24-0.41
GDPY 11.00-2.00	11.00	2.00	0.02	0.050	8.00	●			2.40-6.60	0.39-0.79	0.24-0.41

• For cutting speed recommendations and user guide, see pages 380-395

⁽¹⁾ Cutting width tolerance (+/-)

⁽²⁾ Corner radius tolerance (+/-)

For tools, see pages: CGHN-8-10D (270) • GADR/L-JHP (270) • GHDR/L (long pocket) (268)

CUTGRIP

GIF-E (W=4-6 full radius)

Precision Double-Ended Full Radius Inserts for Profiling and Grooving

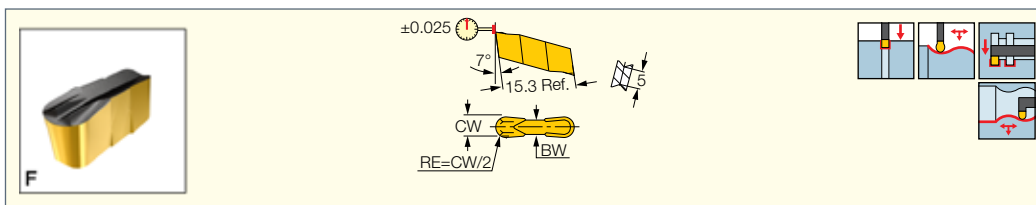

Designation	Dimensions							Tough ↔ Hard				Recommended Machining Data		
	CW	RE	CWTOL ⁽¹⁾	RETOL ⁽²⁾	BW	CDX	IC830	IC8250	IC808	IC20	a _p (mm)	f turn (mm/rev)	f groove (mm/rev)	
GIF 4.00E-2.00	4.00	2.00	0.02	0.050	3.20	11.80	●	●	●	●	0.00-2.00	0.20-0.34	0.09-0.17	
GIF 5.00E-2.50	5.00	2.50	0.02	0.050	4.00	11.30	●	●		●	0.00-2.50	0.23-0.42	0.11-0.21	
GIF 6.00E-3.00	6.00	3.00	0.02	0.050	4.80	10.80	●	●		●	0.00-3.00	0.24-0.50	0.13-0.25	

• DMIN for internal machining = 70 mm • For cutting speed recommendations and user guide, see pages 380-395

⁽¹⁾ Cutting width tolerance (+/-)

⁽²⁾ Corner radius tolerance (+/-)

For tools, see pages: Anti-Vibration Blades (268) • C#-GHDR/L (259) • CGHN 26-M (340) • CGHN 32-DGM (342) • CGHN 32-M (341) • CGHN-D (266) • CGHN-DG (267) • CGHN-S (266) • CGPAD (265) • CGPAD-JHP (265) • GHDR/L (short pocket) (259) • GHDR/L-JHP (short pocket) (260) • GHDR/L-JHP-MC (short pocket) (261) • GHGR/L (262) • GHMPRL (258) • GHMR/L (258)

CUTGRIP

GIF-E (W=8,10 full radius)

Precision Double-Ended Full Radius Inserts for Profiling and Grooving

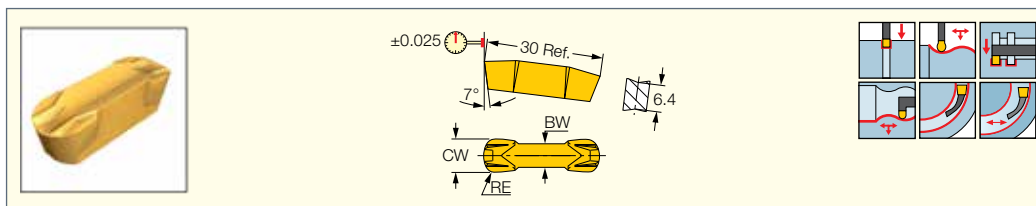

Designation	Dimensions					Tough ↔ Hard		Recommended Machining Data		
	CW	RE	CWTOL ⁽¹⁾	RETOL ⁽²⁾	BW	IC830	IC8250	a _p (mm)	f turn (mm/rev)	f groove (mm/rev)
GIF 8.00E-4.00	8.00	4.00	0.02	0.050	6.00		●	0.00-4.00	0.32-0.67	0.18-0.34
GIF 10.00E-5.00	10.00	5.00	0.02	0.050	8.00	●	●	0.00-5.00	0.35-0.78	0.22-0.40

• DMIN for internal machining = 65 mm • For cutting speed recommendations and user guide, see pages 380-395

⁽¹⁾ Cutting width tolerance (+/-)

⁽²⁾ Corner radius tolerance (+/-)

For tools, see pages: C#-GHDR/L (259) • CGHN-8-10D (270) • GADR/L-8 (269) • GADR/L-JHP (270) • GAFG-R/L-8 (562) • GHDR/L (long pocket) (268) • GHDR/L-JHP (long pocket) (268) • GHFG-R/L-8 (561) • GHFGR/L-8 (561) • GHIR/L (W=7.0-8.3) (339)

CUTGRIP

GIP-E (full radius)
Precision Double-Ended
Full Radius Inserts for
Profiling and Grooving

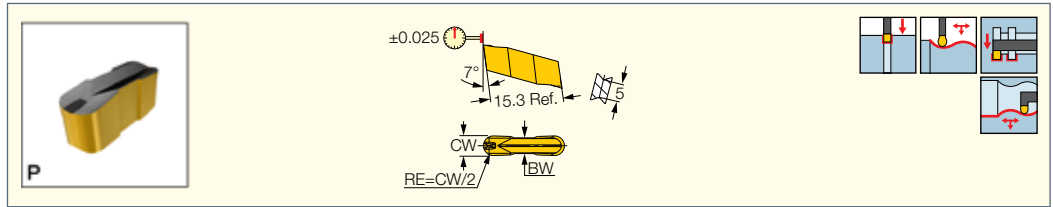

Designation	Dimensions						Tough ← Hard								Recommended Machining Data			
	CW	RE	CWTOL ⁽¹⁾	RETOL ⁽²⁾	BW	CDX	IC830	IC8250	IC808	IC908	IC20	IC5010	IC428	IC807	IC804	a _p (mm)	f turn (mm/rev)	f groove (mm/rev)
GIP 3.00E-1.50	3.00	1.50	0.02	0.050	2.40	12.30	●	●	●	●	●	●	●	●	●	0.00-1.50	0.18-0.28	0.08-0.15
GIP 4.00E-2.00	4.00	2.00	0.02	0.050	3.20	11.80	●	●	●	●	●	●	●	●	●	0.00-2.00	0.20-0.34	0.10-0.20
GIP 5.00E-2.50	5.00	2.50	0.02	0.050	4.00	11.30	●	●	●	●	●	●	●	●	●	0.00-2.50	0.25-0.42	0.13-0.23
GIP 6.00E-3.00	6.00	3.00	0.02	0.050	4.80	10.80	●	●	●	●	●	●	●	●	●	0.00-3.00	0.27-0.54	0.15-0.27
GIP 6.35E-3.18	6.35	3.18	0.02	0.050	4.80	10.63	●	●	●	●	●	●	●	●	●	0.00-3.10	0.29-0.57	0.16-0.29

• DMIN for internal machining = 70 mm • For cutting speed recommendations and user guide, see pages 380-395

⁽¹⁾ Cutting width tolerance (+/-)

⁽²⁾ Corner radius tolerance (+/-)

For tools, see pages: C#-GHDR/L (259) • CGHN 26-M (340) • CGHN 32-DGM (342) • CGHN 32-M (341) • CGHN-D (266) • CGHN-DG (267) • CGHN-S (266) • CGPAD (265) • CGPAD-JHP (265) • GHDR/L (short pocket) (259) • GHDR/L-JHP (short pocket) (260) • GHDR/L-JHP-MC (short pocket) (261) • GHGR/L (262) • GHMPR/L (258) • GHMR/L (258) • GHSR/L (357) • GHSR/L-JHP-SL (358)

CUTGRIP

GIP (flat top W<M)
Flat Top Precision Double-Ended
Inserts for Grooving

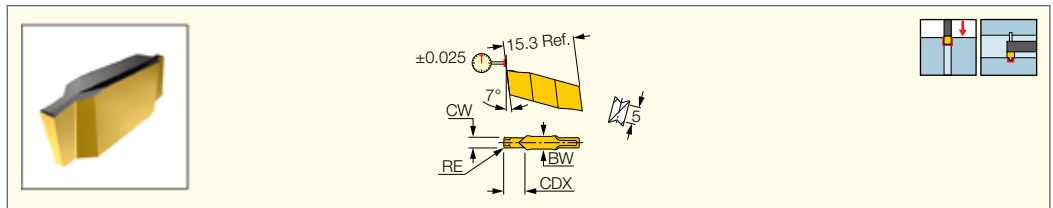

Designation	Dimensions						Tough ← Hard						Recommended Machining Data
	CW	RE	CWTOL ⁽¹⁾	RETOL ⁽²⁾	CDX	BW	IC830	IC808	IC908	IC20	IC20N	IC807	f groove (mm/rev)
GIP 0.50-0.00	0.50	0.00	0.02	0.030	1.00	2.20		●		●			0.02-0.04
GIP 0.80-0.00	0.80	0.00	0.02	0.030	1.60	2.20		●		●			0.02-0.04
GIP 1.04-0.00	1.04	0.00	0.02	0.030	2.00	2.20	●	●		●		●	0.02-0.05
GIP 1.20-0.00	1.20	0.00	0.02	0.030	2.00	2.20	●	●	●	●		●	0.03-0.05
GIP 1.40-0.00	1.40	0.00	0.02	0.030	2.00	2.20	●	●	●	●		●	0.03-0.06
GIP 1.47-0.00	1.47	0.00	0.02	0.030	2.50	2.20	●	●	●	●		●	0.03-0.06
GIP 1.57-0.15	1.57	0.15	0.02	0.030	2.70	2.20	●	●	●	●		●	0.04-0.06
GIP 1.70-0.10	1.70	0.10	0.02	0.030	3.00	2.20	●	●		●	●	●	0.04-0.07
GIP 1.78-0.18	1.78	0.18	0.02	0.030	3.00	2.20	●	●		●	●	●	0.04-0.07
GIP 1.96-0.15	1.96	0.15	0.02	0.030	3.00	2.20	●	●		●	●	●	0.04-0.08

• DMIN for internal machining = 70 mm • For cutting speed recommendations and user guide, see pages 380-395

⁽¹⁾ Cutting width tolerance (+/-)

⁽²⁾ Corner radius tolerance (+/-)

For tools, see pages: GHDR/L (short pocket) (259) • GHGR/L (262) • GHMPR/L (258) • GHMR/L (258)

CUTGRIP

GIP (full radius W<M)

Flat Top Precision Double-Ended Inserts with Full Radius for Grooving

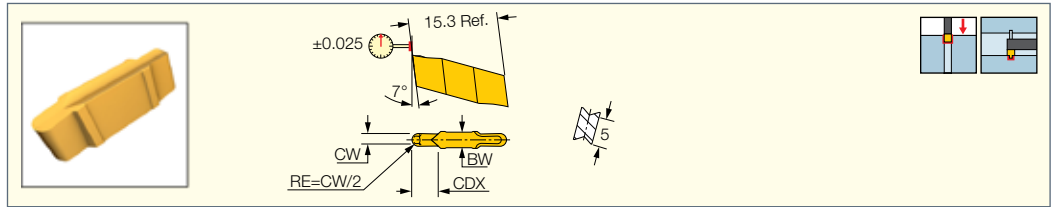

Designation	Dimensions						Tough ↔ Hard					Recommended Machining Data f groove (mm/rev)	
	CW	RE	CWTOL ⁽¹⁾	RETOL ⁽²⁾	CDX	BW	IC830	IC808	IC908	IC20	IC806		IC807
GIP 1.00-0.50	1.00	0.50	0.02	0.050	2.00	2.20		●				●	0.03-0.06
GIP 1.40-0.70	1.40	0.70	0.02	0.050	2.00	2.20		●				●	0.04-0.07
GIP 1.57-0.79	1.57	0.79	0.02	0.050	2.70	2.20	●	●	●	●		●	0.04-0.08
GIP 2.00-1.00	2.00	1.00	0.02	0.050	3.00	2.20	●	●		●	●	●	0.05-0.11
GIP 2.39-1.20	2.39	1.20	0.02	0.050	4.70	2.40		●		●		●	0.06-0.12

• DMIN for internal machining = 70 mm • For cutting speed recommendations and user guide, see pages 380-395

⁽¹⁾ Cutting width tolerance (+/-)

⁽²⁾ Corner radius tolerance (+/-)

For tools, see pages: GHDR/L (short pocket) (259) • GHGR/L (262) • GHMPR/L (258) • GHMR/L (258) • GHSR/L (357) • GHSR/L-JHP-SL (358)

CUTGRIP

GIG

Precision Double-Ended Inserts for Grooving

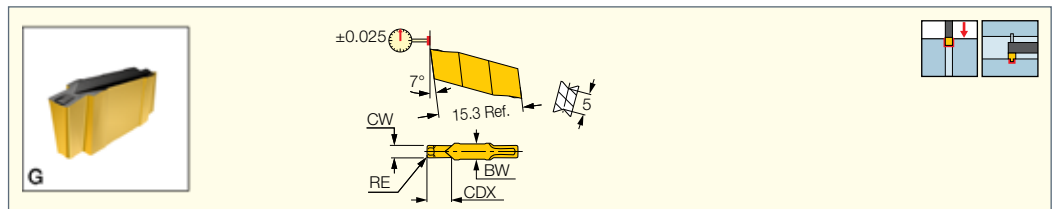

Designation	Dimensions						Tough ↔ Hard			Recommended Machining Data f groove (mm/rev)
	CW	RE	CWTOL ⁽¹⁾	RETOL ⁽²⁾	CDX	BW	IC830	IC808	IC20	
GIG 1.04-0.00	1.04	0.00	0.02	0.030	2.00	2.20		●		0.02-0.03
GIG 1.20-0.00	1.20	0.00	0.02	0.030	2.00	2.20		●		0.02-0.03
GIG 1.25-0.10	1.25	0.10	0.02	0.030	2.00	2.20	●	●		0.02-0.04
GIG 1.40-0.00	1.40	0.00	0.02	0.030	2.00	2.20		●		0.02-0.04
GIG 1.45-0.10	1.45	0.10	0.02	0.030	2.00	2.20	●	●		0.02-0.04
GIG 1.47-0.00	1.47	0.00	0.02	0.030	2.50	2.20		●		0.02-0.04
GIG 1.50-0.10	1.50	0.10	0.02	0.030	2.50	2.20	●	●		0.02-0.04
GIG 1.57-0.15	1.57	0.15	0.02	0.030	2.70	2.20		●		0.03-0.05
GIG 1.70-0.10	1.70	0.10	0.02	0.030	3.00	2.20		●		0.03-0.05
GIG 1.78-0.18	1.78	0.18	0.02	0.030	3.00	2.20		●		0.03-0.05
GIG 1.85-0.15	1.85	0.15	0.02	0.030	3.00	2.20	●	●		0.03-0.05
GIG 1.86-0.15	1.86	0.15	0.02	0.030	3.00	2.20		●		0.03-0.05
GIG 1.96-0.15	1.96	0.15	0.02	0.030	3.00	2.20		●		0.03-0.06
GIG 2.00-0.20	2.00	0.20	0.02	0.030	3.00	2.20	●	●	●	0.04-0.06
GIG 2.22-0.15	2.22	0.15	0.02	0.030	3.50	2.20		●		0.04-0.06
GIG 2.30-0.20	2.30	0.20	0.02	0.030	3.50	2.20	●	●		0.04-0.07

• DMIN for internal machining = 70 mm • For cutting speed recommendations and user guide, see pages 380-395

⁽¹⁾ Cutting width tolerance (+/-)

⁽²⁾ Corner radius tolerance (+/-)

For tools, see pages: GHDR/L (short pocket) (259) • GHGR/L (262) • GHMPR/L (258) • GHMR/L (258) • GHSR/L (357) • GHSR/L-JHP-SL (358)

CUTGRIP

GIP
Precision Double-Ended
Inserts for Grooving

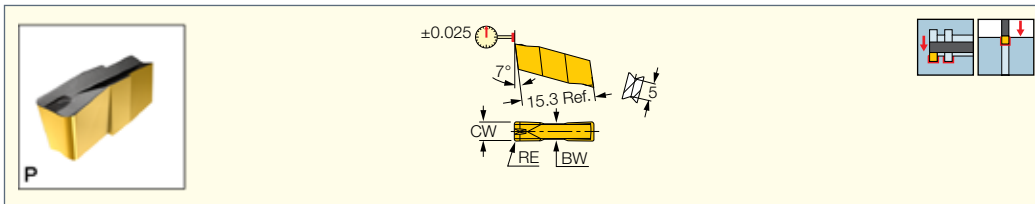

Designation	Dimensions						Tough ↔ Hard							Recommended Machining Data f groove (mm/rev)
	CW	RE	CWTOL ⁽¹⁾	RETOL ⁽²⁾	CDX	BW	IC830	IC8250	IC808	IC20	IC20N	IC806	IC807	
GIP 2.22-0.15	2.22	0.15	0.02	0.030	3.50	2.20	●		●	●			●	0.05-0.09
GIP 2.39-0.15	2.39	0.15	0.02	0.030	4.70	2.40	●		●	●	●		●	0.05-0.09
GIP 2.47-0.20	2.47	0.20	0.02	0.030	5.00	2.40	●		●	●	●		●	0.06-0.10
GIP 2.70-0.10	2.70	0.10	0.02	0.030	13.00	2.40	●		●	●			●	0.06-0.10
GIP 2.70-0.20	2.70	0.20	0.02	0.030	13.00	2.40		●	●	●				0.07-0.11
GIP 2.87-0.20	2.87	0.20	0.02	0.030	13.00	2.40	●		●	●				0.07-0.12
GIP 3.00-0.00	3.00	0.00	0.02	0.030	13.00	2.40	●		●	●				0.07-0.11
GIP 3.00-0.20	3.00	0.20	0.02	0.030	13.00	2.40	●		●	●		●	●	0.08-0.13
GIP 3.00-0.40	3.00	0.40	0.02	0.030	13.00	2.40			●	●				0.08-0.14
GIP 3.15-0.15	3.15	0.15	0.02	0.030	13.00	2.40	●	●	●	●	●			0.07-0.12
GIP 3.18-0.20	3.18	0.20	0.02	0.030	13.00	2.40	●	●	●	●			●	0.08-0.13
GIP 3.30-0.10	3.30	0.10	0.02	0.030	13.00	2.40	●	●	●	●				0.07-0.12
GIP 3.48-0.20	3.48	0.20	0.02	0.030	13.00	3.20		●	●	●				0.09-0.15
GIP 3.56-0.20	3.56	0.20	0.02	0.030	13.00	3.20		●	●	●				0.09-0.15
GIP 3.74-0.20	3.74	0.20	0.02	0.030	13.00	3.20		●	●	●				0.09-0.16
GIP 3.98-0.20	3.98	0.20	0.02	0.030	13.00	3.20	●	●	●	●			●	0.10-0.17
GIP 4.00-0.80	4.00	0.80	0.02	0.050	13.00	3.20			●	●				0.10-0.20
GIP 4.23-0.10	4.23	0.10	0.02	0.030	13.00	3.20	●	●	●	●				0.10-0.16
GIP 5.00-0.40	5.00	0.40	0.02	0.030	13.00	4.00			●	●				0.13-0.21
GIP 6.00-0.40	6.00	0.40	0.02	0.030	13.00	4.80			●	●				0.15-0.25
GIP 6.00-0.80	6.00	0.80	0.02	0.050	13.00	4.80			●	●				0.15-0.27

• DMIN for internal machining = 70 mm • For cutting speed recommendations and user guide, see pages 380-395

⁽¹⁾ Cutting width tolerance (+/-)

⁽²⁾ Corner radius tolerance (+/-)

For tools, see pages: Anti-Vibration Blades (268) • C#-GHDR/L (259) • CGHN 26-M (340) • CGHN 32-DGM (342) • CGHN 32-M (341) • CGHN-D (266) • CGHN-DG (267) • CGHN-S (266) • CGPAD (265) • CGPAD-JHP (265) • GHDR/L (short pocket) (259) • GHDR/L-JHP (short pocket) (260) • GHDR/L-JHP-MC (short pocket) (261) • GHGR/L (262) • GHMPR/L (258) • GHMR/L (258) • GHSR/L (357) • GHSR/L-JHP-SL (358)

CUTGRIP

GIP (full radius)
Precision Double-Ended Full
Radius Inserts for Grooving

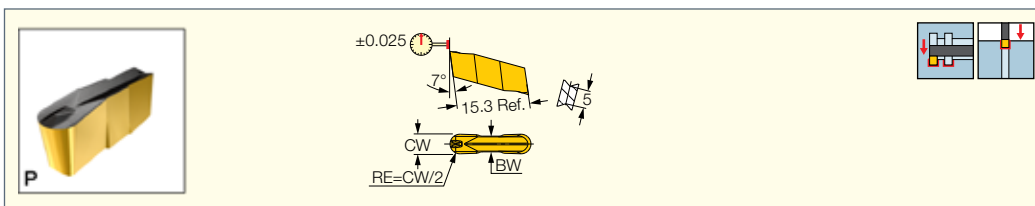

Designation	Dimensions						Tough ↔ Hard					Recommended Machining Data f groove (mm/rev)
	CW	RE	CWTOL ⁽¹⁾	RETOL ⁽²⁾	CDX	BW	IC830	IC8250	IC808	IC20	IC804	
GIP 3.00-1.50	3.00	1.50	0.02	0.050	12.30	2.40				●	●	0.08-0.15
GIP 3.18-1.59	3.18	1.59	0.02	0.050	12.20	2.40	●		●	●		0.08-0.16
GIP 3.98-1.99	3.98	1.99	0.02	0.050	11.80	3.20		●	●	●		0.10-0.20
GIP 4.78-2.39	4.78	2.39	0.02	0.050	11.40	4.80			●	●		0.12-0.22
GIP 5.00-2.50	5.00	2.50	0.02	0.050	11.30	4.00				●		0.13-0.23

• For cutting speed recommendations and user guide, see pages 380-395

⁽¹⁾ Cutting width tolerance (+/-)

⁽²⁾ Corner radius tolerance (+/-)

For tools, see pages: C#-GHDR/L (259) • CGHN 26-M (340) • CGHN 32-DGM (342) • CGHN 32-M (341) • CGHN-D (266) • CGHN-DG (267) • CGHN-S (266) • CGPAD (265) • CGPAD-JHP (265) • GHDR/L (short pocket) (259) • GHDR/L-JHP (short pocket) (260) • GHDR/L-JHP-MC (short pocket) (261) • GHGR/L (262) • GHMPR/L (258) • GHMR/L (258) • GHSR/L (357) • GHSR/L-JHP-SL (358)

GIF
Precision Double-Ended
Inserts for Grooving

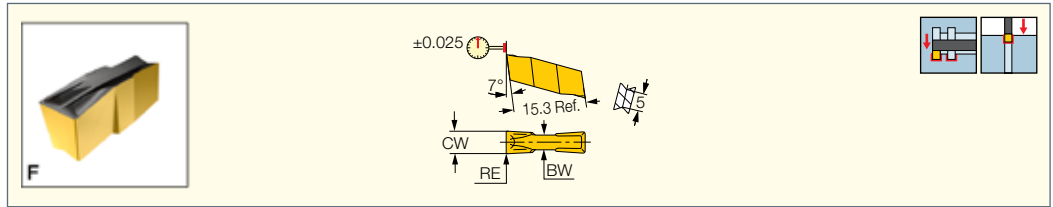

Designation	Dimensions						Tough ↔ Hard				Recommended Machining Data	
	CW	RE	CWTOL ⁽¹⁾	RETOL ⁽²⁾	BW	CDX	IC830	IC8250	IC808	IC20	f groove (mm/rev)	
GIF 3.48-0.20	3.48	0.20	0.02	0.030	3.20	13.00	●	●	●	●	0.08-0.12	
GIF 3.56-0.20	3.56	0.20	0.02	0.030	3.20	13.00		●	●		0.08-0.13	
GIF 3.74-0.20	3.74	0.20	0.02	0.030	3.20	13.00		●	●		0.08-0.13	
GIF 3.98-0.20	3.98	0.20	0.02	0.030	3.20	13.00	●	●	●	●	0.09-0.14	
GIF 4.23-0.10	4.23	0.10	0.02	0.030	3.20	13.00	●	●	●		0.08-0.13	
GIF 4.45-0.15	4.45	0.15	0.02	0.030	4.00	13.00	●	●	●	●	0.09-0.14	
GIF 4.78-0.55	4.78	0.55	0.02	0.050	4.00	13.00	●	●	●	●	0.11-0.18	
GIF 4.86-0.30	4.86	0.30	0.02	0.030	4.00	13.00		●	●	●	0.11-0.18	
GIF 5.28-0.20	5.28	0.20	0.02	0.030	4.00	13.00		●	●	●	0.12-0.18	
GIF 5.39-0.20	5.39	0.20	0.02	0.030	4.00	13.00		●	●	●	0.12-0.19	
GIF 5.90-0.20	5.90	0.20	0.02	0.030	4.80	13.00		●	●		0.12-0.21	
GIF 6.35-0.50	6.35	0.50	0.02	0.050	4.80	13.00		●	●	●	0.14-0.24	
GIF 6.35-0.55	6.35	0.55	0.02	0.050	4.80	13.00		●	●		0.14-0.24	

• DMIN for internal machining = 70 mm • For cutting speed recommendations and user guide, see pages 380-395

⁽¹⁾ Cutting width tolerance (+/-)

⁽²⁾ Corner radius tolerance (+/-)

For tools, see pages: Anti-Vibration Blades (268) • C#-GHDR/L (259) • CGHN 26-M (340) • CGHN 32-DGM (342) • CGHN 32-M (341) • CGHN-D (266) • CGHN-DG (267) • CGHN-S (266) • CGPAD (265) • CGPAD-JHP (265) • GHDR/L (short pocket) (259) • GHDR/L-JHP (short pocket) (260) • GHDR/L-JHP-MC (short pocket) (261) • GHGR/L (262) • GHMPR/L (258) • GHMR/L (258)

GIF (long pocket)
Precision Double-Ended
Inserts for Grooving

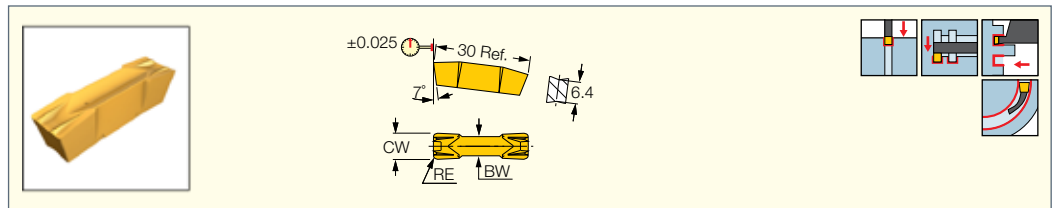

Designation	Dimensions						Tough ↔ Hard		Recommended Machining Data	
	CW	RE	CWTOL ⁽¹⁾	RETOL ⁽²⁾	BW	CDX	IC20	IC806	f groove (mm/rev)	f face-groove (mm/rev)
GIF 8.00-0.40	8.00	0.40	0.02	0.030	6.00	27.00	●	●	0.18-0.31	0.14-0.23
GIF 8.00-0.80	8.00	0.80	0.02	0.050	6.00	27.00	●	●	0.18-0.34	0.14-0.25

• DMIN for internal machining = 65 mm • For cutting speed recommendations and user guide, see pages 380-395

⁽¹⁾ Cutting width tolerance (+/-)

⁽²⁾ Corner radius tolerance (+/-)

For tools, see pages: C#-GHDR/L (259) • CGHN-8-10D (270) • GADR/L-JHP (270) • GAFG-R/L-8 (562) • GHDR/L (long pocket) (268) • GHDR/L-JHP (long pocket) (268) • GHFG-R/L-8 (561) • GHFGR/L-8 (561)

CUTGRIP

GIF (full radius)

Precision Double-Ended Full Radius Inserts for Grooving

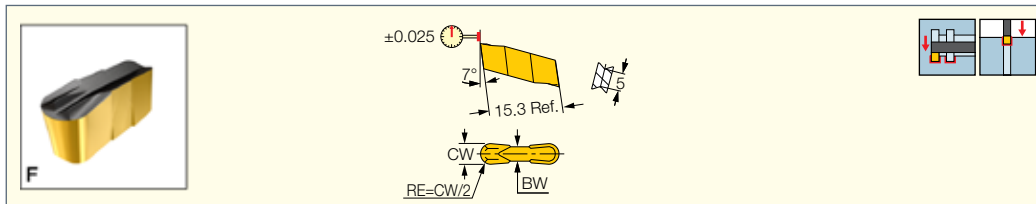

Designation	Dimensions						Tough ↔ Hard			Recommended Machining Data
	CW	RE	CWTOL ⁽¹⁾	RETOL ⁽²⁾	BW	CDX	IC8250	IC808	IC20	
GIF 4.78-2.39	4.78	2.39	0.02	0.050	4.00	11.40	●	●		f groove (mm/rev) 0.11-0.20
GIF 6.35-3.18	6.35	3.18	0.02	0.050	4.80	10.60			●	0.14-0.27

• DMIN for internal machining = 70 mm • For cutting speed recommendations and user guide, see pages 380-395

⁽¹⁾ Cutting width tolerance (+/-)

⁽²⁾ Corner radius tolerance (+/-)

For tools, see pages: Anti-Vibration Blades (268) • C#-GHDR/L (259) • CGHN 26-M (340) • CGHN 32-DGM (342) • CGHN 32-M (341) • CGHN-D (266) • CGHN-DG (267) • CGHN-S (266) • CGPAD (265) • CGPAD-JHP (265) • GHDR/L (short pocket) (259) • GHDR/L-JHP (short pocket) (260) • GHDR/L-JHP-MC (short pocket) (261) • GHGR/L (262) • GHMPR/L (258) • GHMR/L (258)

CUTGRIP

GIA-K (W=3-6)

Flat Top Precision Double-Ended Inserts with T-Land for Machining Cast Iron

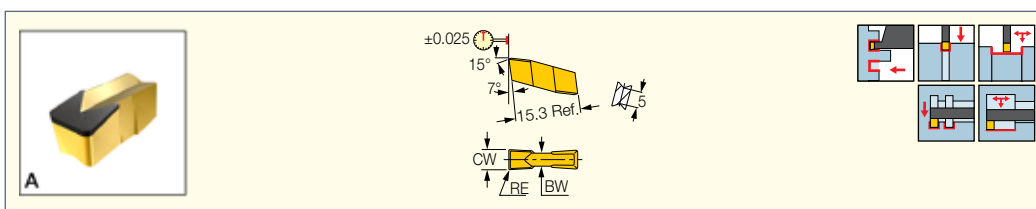

Designation	Dimensions						Tough ↔ Hard		Recommended Machining Data		
	CW	RE	CWTOL ⁽¹⁾	RETOL ⁽²⁾	BW	CDX	IC5010	IC428	a _p (mm)	f turn (mm/rev)	f groove (mm/rev)
GIA 3.00K-0.40	3.00	0.40	0.02	0.030	2.40	13.00	●	●	0.50-1.80	0.12-0.20	0.07-0.13
GIA 4.00K-0.40	4.00	0.40	0.02	0.030	3.20	13.00	●	●	0.50-2.40	0.16-0.27	0.09-0.18
GIA 4.00K-0.80	4.00	0.80	0.02	0.050	3.20	13.00	●	●	1.00-2.40	0.18-0.32	0.09-0.19
GIA 5.00K-0.80	5.00	0.80	0.02	0.050	4.00	13.00	●	●	1.00-3.00	0.23-0.40	0.11-0.24
GIA 6.00K-0.80	6.00	0.80	0.02	0.050	4.80	13.00	●	●	1.00-3.60	0.27-0.48	0.14-0.29

• DMIN for internal machining = 70 mm • For cutting speed recommendations and user guide, see pages 380-395

⁽¹⁾ Cutting width tolerance (+/-)

⁽²⁾ Corner radius tolerance (+/-)

For tools, see pages: Anti-Vibration Blades (268) • C#-GHDR/L (259) • CGHN 26-M (340) • CGHN 32-DGM (342) • CGHN 32-M (341) • CGHN-D (266) • CGHN-DG (267) • CGHN-S (266) • CGPAD-JHP (265) • GHDR/L (short pocket) (259) • GHDR/L-JHP (short pocket) (260) • GHDR/L-JHP-MC (short pocket) (261) • GHGR/L (262) • GHMPR/L (258) • GHMR/L (258)

CUTGRIP

GIA-K (long pocket)

Flat Top Precision Double-Ended Inserts with T-Land for Machining Cast Iron

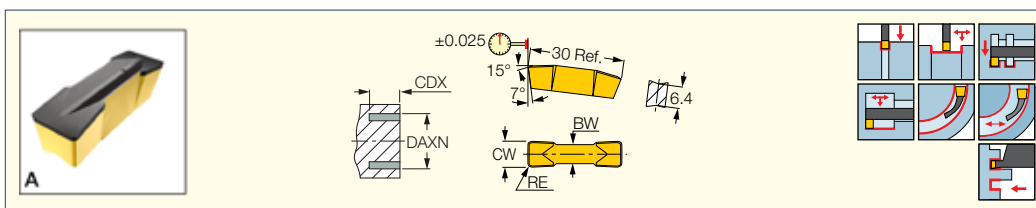

Designation	Dimensions							Tough ↔ Hard		Recommended Machining Data		
	CW	RE	CWTOL ⁽¹⁾	RETOL ⁽²⁾	BW	CDX ⁽³⁾	DAXN ⁽⁴⁾	IC5010	IC428	a _p (mm)	f turn (mm/rev)	f groove (mm/rev)
GIA 8.00K-0.80	8.00	0.80	0.02	0.050	6.00	25.00	160.0	●	●	1.00-4.80	0.36-0.64	0.18-0.38
GIA 8.00K-1.20	8.00	1.20	0.02	0.050	6.00	25.00	160.0	●	●	1.45-4.80	0.36-0.70	0.18-0.38

• DMIN for internal machining = 65 mm • For cutting speed recommendations and user guide, see pages 380-395

⁽¹⁾ Cutting width tolerance (+/-)

⁽²⁾ Corner radius tolerance (+/-)

⁽³⁾ Cutting depth maximum

⁽⁴⁾ Minimum axial grooving diameter

For tools, see pages: C#-GHDR/L (259) • CGHN-8-10D (270) • GADR/L-8 (269) • GADR/L-JHP (270) • GAFG-R/L-8 (562) • GHDR/L (long pocket) (268) • GHDR/L-JHP (long pocket) (268) • GHFG-R/L-8 (561) • GHFGR/L-8 (561) • GHIR/L (W=7.0-8.3) (339)

GITM

CBN Tipped Inserts for Turning and Grooving on Hard Ferrous Materials

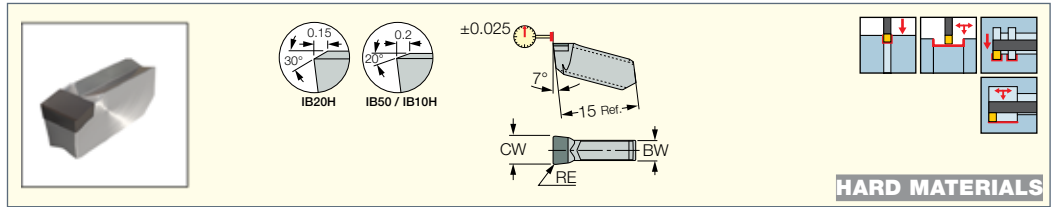

Designation	Dimensions					Tough ↔ Hard			Recommended Machining Data		
	CW	RE	RETOL ⁽¹⁾	CWTOL ⁽²⁾	BW	IB20H	IB50	IB10H	a _p (mm)	f turn (mm/rev)	f groove (mm/rev)
GITM 3.00K-0.20	3.00	0.20	0.050	0.02	2.40	●	●	●	0.00-0.30	0.02-0.07	0.02-0.05
GITM 4.00K-0.20	4.00	0.20	0.050	0.02	3.20	●	●	●	0.00-0.40	0.03-0.09	0.02-0.07
GITM 5.00K-0.40	5.00	0.40	0.050	0.02	4.00	●	●	●	0.00-0.50	0.05-0.13	0.03-0.10
GITM 6.00K-0.40	6.00	0.40	0.050	0.02	4.95	●	●	●	0.00-0.60	0.05-0.15	0.04-0.12
GITM 8.00K-0.40	8.00	0.40	0.050	0.02	6.00	●	●	●	0.00-0.80	0.07-0.20	0.05-0.16

• DMIN for internal machining = 70 mm • For cutting speed recommendations and user guide, see pages 380-395

⁽¹⁾ Corner radius tolerance (+/-)

⁽²⁾ Cutting width tolerance (+/-)

For tools, see pages: Anti-Vibration Blades (268) • C#-GHDR/L (259) • CGHN 26-M (340) • CGHN 32-DGM (342) • CGHN 32-M (341) • CGHN-D (266) • CGHN-DG (267) • CGHN-S (266) • CGPAD (265) • CGPAD-JHP (265) • GHDR/L (short pocket) (259) • GHDR/L-JHP (short pocket) (260) • GHDR/L-JHP-MC (short pocket) (261) • GHGR/L (262) • GHMPR/L (258) • GHMR/L (258) • GHSR/L (357) • GHSR/L-JHP-SL (358)

GITM (full radius)

Full Radius CBN Tipped Inserts for Grooving and Turning on Hard Ferrous Materials

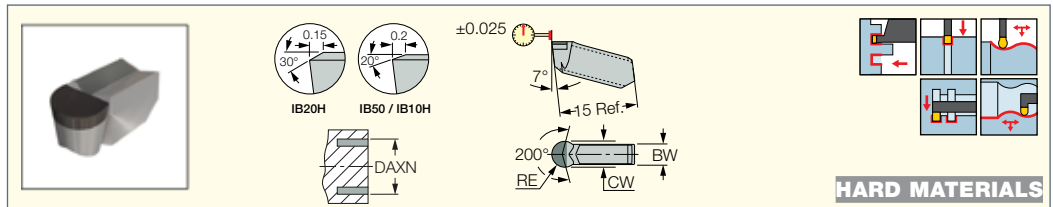

Designation	Dimensions						Tough ↔ Hard			Recommended Machining Data		
	CW	RE	CWTOL ⁽¹⁾	RETOL ⁽²⁾	BW	DAXN ⁽³⁾	IB20H	IB50	IB10H	a _p (mm)	f turn (mm/rev)	f groove (mm/rev)
GITM 3.00K-1.50	3.00	1.50	0.02	0.050	2.40	160.0	●	●	●	0.00-0.30	0.03-0.10	0.02-0.06
GITM 4.00K-2.00	4.00	2.00	0.02	0.050	3.20	160.0	●	●	●	0.00-0.40	0.04-0.14	0.02-0.09
GITM 5.00K-2.50	5.00	2.50	0.02	0.050	3.90	160.0	●	●	●	0.00-0.50	0.05-0.18	0.03-0.11
GITM 6.00K-3.00	6.00	3.00	0.02	0.050	5.00	160.0	●	●	●	0.00-0.60	0.06-0.22	0.04-0.13
GITM 8.00K-4.00	8.00	4.00	0.02	0.050	5.60	160.0	●	●	●	0.00-0.80	0.08-0.29	0.05-0.17

• DMIN for internal machining = 70 mm • For cutting speed recommendations and user guide, see pages 380-395

⁽¹⁾ Cutting width tolerance (+/-)

⁽²⁾ Corner radius tolerance (+/-)

⁽³⁾ Minimum axial grooving diameter

For tools, see pages: Anti-Vibration Blades (268) • C#-GHDR/L (259) • CGHN 26-M (340) • CGHN 32-DGM (342) • CGHN 32-M (341) • CGHN-D (266) • CGHN-DG (267) • CGHN-S (266) • CGPAD (265) • CGPAD-JHP (265) • GHDR/L (short pocket) (259) • GHDR/L-JHP (short pocket) (260) • GHDR/L-JHP-MC (short pocket) (261) • GHGR/L (262) • GHMPR/L (258) • GHMR/L (258) • GHSR/L (357) • GHSR/L-JHP-SL (358)

CUTGRIP

GIPI

Single-Ended Full Radius
Sharp Edged Precision
Inserts for Profiling of High
Temperature Alloys

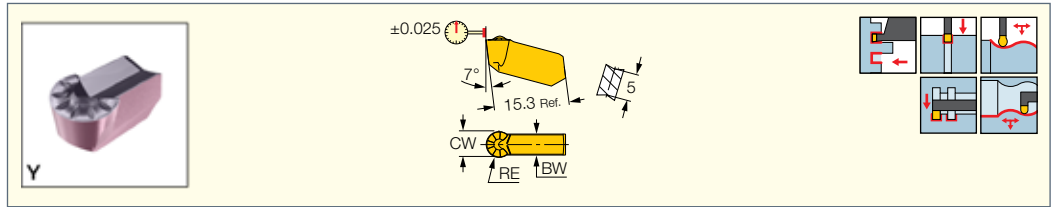

Designation	Dimensions					Tough ↔ Hard						Recommended Machining Data	
	CW	RE	CWTOL ⁽¹⁾	RETOL ⁽²⁾	BW	IC20	IC07	IC806	IC907	IC4	IC804	f turn (mm/rev)	f groove (mm/rev)
GIPI 3.00-1.50	3.00	1.50	0.00	0.050	2.40	●	●	●	●	●	●	0.19-0.28	0.08-0.15
GIPI 4.00-2.00	4.00	2.00	0.00	0.050	3.20	●		●	●	●	●	0.22-0.37	0.10-0.20
GIPI 5.00-2.50	5.00	2.50	0.00	0.050	3.90	●		●	●	●	●	0.24-0.46	0.13-0.23
GIPI 6.00-3.00	6.00	3.00	0.00	0.050	5.00	●		●	●	●		0.26-0.55	0.15-0.27
GIPI 8.00-4.00	8.00	4.00	0.02	0.050	5.60	●	●	●	●			0.34-0.74	0.20-0.36

• Can cut arcs to 250° • DMIN for internal machining = 70 mm • For cutting speed recommendations and user guide, see pages 380-395

⁽¹⁾ Cutting width tolerance (+/-)

⁽²⁾ Corner radius tolerance (+/-)

For tools, see pages: Anti-Vibration Blades (268) • C#-GHDR/L (259) • CGFG 51-P8 (563) • CGHN 26-M (340) • CGHN 32-DGM (342) • CGHN 32-M (341) • CGHN-D (266) • CGHN-DG (267) • CGHN-P8 (267) • CGHN-S (266) • CGHR/L-P8DG (267) • CGPAD (265) • CGPAD-JHP (265) • GHDR/L (short pocket) (259) • GHDR/L-JHP (short pocket) (260) • GHDR/L-JHP-MC (short pocket) (261) • GHGR/L (262) • GHMPR/L (258) • GHMR/L (258) • GHSR/L (357) • GHSR/L-JHP-SL (358)

CUTGRIP

GIPA (W=3-6)

Double-Ended Precision Ground
Inserts with a Polished Top
Rake for Machining Aluminum

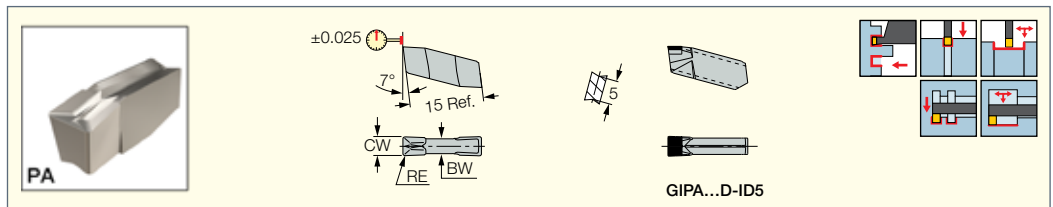

Designation	Dimensions					Tough ↔ Hard		Recommended Machining Data		
	CW	RE	CWTOL ⁽²⁾	RETOL ⁽³⁾	BW	IC20	ID5	a _p (mm)	f turn (mm/rev)	f groove (mm/rev)
GIPA 3.00-0.20	3.00	0.20	0.02	0.030	2.40	●		0.25-1.80	0.12-0.20	0.08-0.14
GIPA 3.00-0.20-D ⁽¹⁾	3.00	0.20	0.02	0.030	2.40		●	0.25-1.80	0.12-0.25	0.09-0.16
GIPA 4.00-0.40	4.00	0.40	0.02	0.030	3.20	●		0.50-2.40	0.14-0.31	0.10-0.20
GIPA 5.00-0.40	5.00	0.40	0.02	0.030	4.00	●		0.50-3.00	0.16-0.34	0.11-0.23
GIPA 6.00-0.40	6.00	0.40	0.02	0.030	4.80	●		0.50-3.60	0.19-0.41	0.11-0.26

• DMIN for internal machining = 70 mm • For cutting speed recommendations and user guide, see pages 380-395

⁽¹⁾ Single-ended PCD tipped insert

⁽²⁾ Cutting width tolerance (+/-)

⁽³⁾ Corner radius tolerance (+/-)

For tools, see pages: Anti-Vibration Blades (268) • C#-GHDR/L (259) • CGHN 26-M (340) • CGHN 32-DGM (342) • CGHN 32-M (341) • CGHN-D (266) • CGHN-DG (267) • CGHN-S (266) • CGPAD (265) • CGPAD-JHP (265) • GHDR/L (short pocket) (259) • GHDR/L-JHP (short pocket) (260) • GHDR/L-JHP-MC (short pocket) (261) • GHGR/L (262) • GHMPR/L (258) • GHMR/L (258) • GHSR/L (357) • GHSR/L-JHP-SL (358)

CUTGRIP

GDMA

Utility Double-Ended Insert
with a Polished Top Rake
for Machining Aluminum

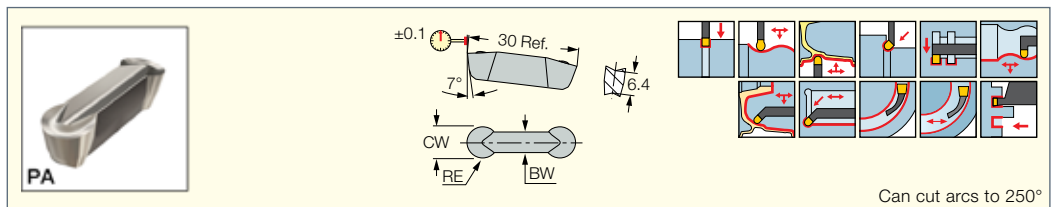

Can cut arcs to 250°

Designation	Dimensions					Tough ↔ Hard		Recommended Machining Data		
	CW	RE	CWTOL ⁽¹⁾	RETOL ⁽²⁾	BW	IC07	IC507	a _p (mm)	f turn (mm/rev)	f groove (mm/rev)
GDMA 840	8.00	4.00	0.05	0.050	5.60	●	●	0.00-4.00	0.24-0.67	0.14-0.38

• For heavy-duty machining • DMIN for internal machining = 65 mm • For cutting speed recommendations and user guide, see pages 380-395

⁽¹⁾ Cutting width tolerance (+/-)

⁽²⁾ Corner radius tolerance (+/-)

For tools, see pages: GADR/L-8 (269) • GADR/L-JHP (270) • GAFG-R/L-8 (562) • GHDKR/L (407) • GHIFR/L-A (406) • GHIR/L (W=7.0-8.3) (339) • GHIUR/L-C-A (15° & 27.5°) Bars (406) • GHIUR/L-UC (406)

GIPA (full radius W=3-6)
Precision Double-Ended
Inserts with Polished Top Rake
for Machining Aluminum

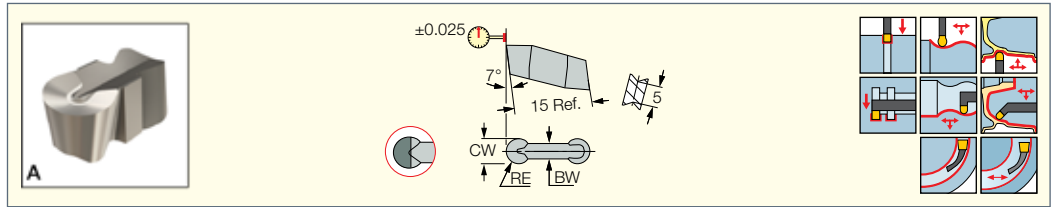

Designation	Dimensions					Tough ↔ Hard				Recommended Machining Data		
	CW	RE	CWTOL ⁽⁴⁾	RETOL ⁽⁵⁾	BW	IC20	IC806	IC4	ID5	a _p (mm)	f turn (mm/rev)	f groove (mm/rev)
GIPA 3.00-1.50	3.00	1.50	0.02	0.050	2.40	●				0.00-1.50	0.15-0.30	0.08-0.16
GIPA 3.00-1.50-D ⁽¹⁾	3.00	1.50	0.02	0.050	2.40				●	0.00-1.50	0.19-0.36	0.09-0.19
GIPA 3.00-1.50YZ-D ⁽²⁾	3.00	1.50	0.02	0.050	2.40				●	0.00-1.50	0.19-0.36	0.09-0.19
GIPA 4.00-2.00	4.00	2.00	0.02	0.050	3.20	●	●			0.00-2.00	0.20-0.43	0.10-0.22
GIPA 4.00-2.00-D ⁽¹⁾	4.00	2.00	0.02	0.050	3.20				●	0.00-2.00	0.25-0.53	0.12-0.26
GIPA 4.00-2.00YZ-D ⁽²⁾	4.00	2.00	0.02	0.050	3.20				●	0.00-2.00	0.25-0.53	0.12-0.26
GIPA 5.00-2.50	5.00	2.50	0.02	0.050	3.90	●	●			0.00-2.50	0.21-0.48	0.09-0.24
GIPA 5.00-2.50-D ⁽¹⁾	5.00	2.50	0.02	0.050	3.90				●	0.00-2.50	0.22-0.60	0.11-0.30
GIPA 5.00-2.50YZ-D ⁽²⁾	5.00	2.50	0.02	0.050	3.90				●	0.00-2.50	0.22-0.60	0.11-0.30
GIPA 6.00-3.00	6.00	3.00	0.02	0.050	4.80	●		●		0.00-3.00	0.21-0.58	0.11-0.29
GIPA 6.00-3.00-D ⁽¹⁾	6.00	3.00	0.02	0.050	4.80				●	0.00-3.00	0.26-0.72	0.13-0.36
GIPA 6.00-3.00YZ	6.00	3.00	0.02	0.050	4.80	●				0.00-3.00	0.21-0.58	0.11-0.29
GIPA 6.00-3.00YZ-D ⁽²⁾	6.00	3.00	0.02	0.050	4.80				●	0.00-3.00	0.26-0.72	0.13-0.36
GIPA 6.00-3.00CB ⁽³⁾	6.00	3.00	0.02	0.050	4.80				●	0.00-3.00	0.21-0.58	0.11-0.29

• For cutting speed recommendations and user guide, see pages 380-395

⁽¹⁾ Single-ended PCD tipped insert

⁽²⁾ Single-ended molded PCD chipformer tipped insert

⁽³⁾ Single-ended flat PCD tipped insert with chip deflector

⁽⁴⁾ Cutting width tolerance (+/-)

⁽⁵⁾ Corner radius tolerance (+/-)

For tools, see pages: Anti-Vibration Blades (268) • C#-GHDR/L (259) • CGHN 26-M (340) • CGHN 32-DGM (342) • CGHN 32-M (341) • CGHN-D (266) • CGHN-DG (267) • CGHN-S (266) • CGPAD (265) • CGPAD-JHP (265) • GHDKR/L (407) • GHDR/L (short pocket) (259) • GHDR/L-JHP (short pocket) (260) • GHDR/L-JHP-MC (short pocket) (261) • GHGR/L (262) • GHIFR/L-A (406) • GHIUR/L-C-A (15° & 27.5°) Bars (406) • GHMPR/L (258) • GHMR/L (258) • GHSR/L (357) • GHSR/L-JHP-SL (358)



CUTGRIP

GIPA/GIDA 8 (full radius)

Precision Double-Ended
Inserts with Polished Top Rake
for Machining Aluminum

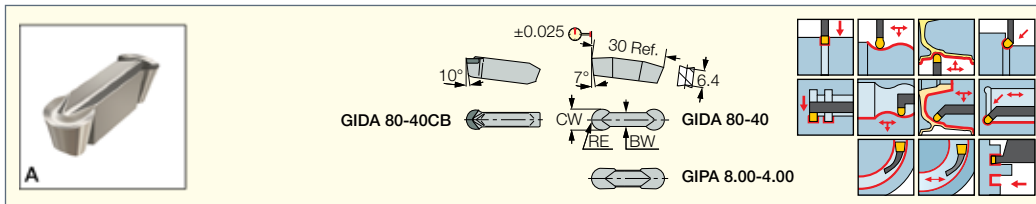

Designation	Dimensions					Tough ↔ Hard			Recommended Machining Data		
	CW	RE	CWTOL ⁽²⁾	RETOL ⁽³⁾	BW	IC20	IC4	ID5	a _p (mm)	f turn (mm/rev)	f groove (mm/rev)
GIDA 80-40	8.00	4.00	0.02	0.050	5.60	●	●		0.00-4.00	0.24-0.67	0.14-0.38
GIDA 80-40-D	8.00	4.00	0.02	0.050	5.60			●	0.00-4.00	0.24-0.67	0.14-0.38
GIDA 80-40CB-D (1)	8.00	4.00	0.02	0.050	5.60			●	0.00-4.00	0.24-0.67	0.14-0.38
GIDA 80-40YZ	8.00	4.00	0.02	0.050	5.60	●	●		0.00-4.00	0.24-0.67	0.14-0.38
GIDA 80-40YZ-D	8.00	4.00	0.02	0.050	5.60			●	0.00-4.00	0.35-0.96	0.18-0.48
GIPA 8.00-4.00	8.00	4.00	0.02	0.050	6.00	●			0.00-4.00	0.24-0.67	0.14-0.38

• ID5 is a single-ended PCD tipped insert • For cutting speed recommendations and user guide, see pages 380-395

⁽¹⁾ Should not be clamped on tools with "A" suffix

⁽²⁾ Cutting width tolerance (+/-)

⁽³⁾ Corner radius tolerance (+/-)

For tools, see pages: C#-GHDR/L (259) • CGHN-8-10D (270) • GADR/L-8 (269) • GADR/L-JHP (270) • GAFG-R/L-8 (562) • GHDKR/L (407) • GHDR/L (long pocket) (268) • GHDR/L-8A (407) • GHDR/L-JHP (long pocket) (268) • GHFR/L-8 (561) • GHFR/L-A (406) • GHIR/L (W=7.0-8.3) (339) • GHIUR/L-C-A (15° & 27.5°) Bars (406) • GHIUR/L-UC (406)

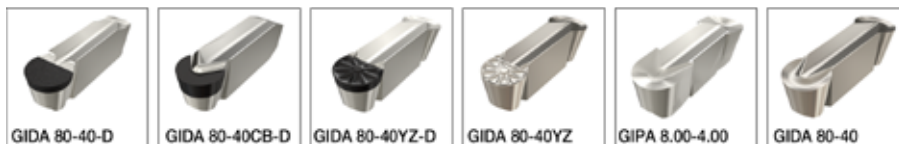

CUTGRIP

GIP-RX/LX

Precision Double-Ended
Inserts for External Grooving
Next to a Shoulder

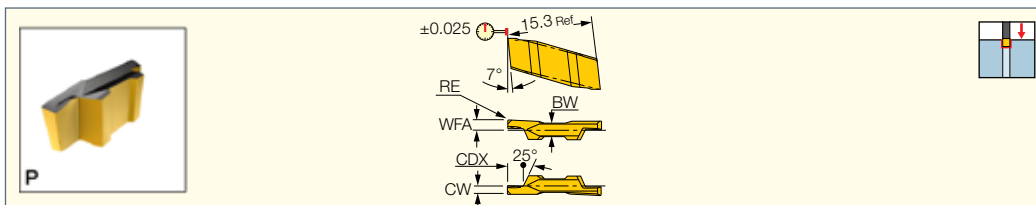

Designation	Dimensions							Tough ↔ Hard		Recommended Machining Data
	CW	RE	CWTOL ⁽¹⁾	RETOL ⁽²⁾	CDX	BW	WFA	IC830	IC808	
GIP 0.80-0.00R/LX	0.80	0.00	0.02	0.030	1.60	2.40	1.6	●		0.02-0.04
GIP 1.00-0.00R/LX	1.00	0.00	0.02	0.030	2.00	2.40	1.6	●		0.02-0.05
GIP 1.19-0.1RX	1.19	0.10	0.02	0.030	2.00	2.40	1.6		●	0.03-0.05
GIP 1.57-0.15 R/LX	1.57	0.15	0.02	0.030	2.70	2.40	1.7	●		0.04-0.06
GIP 1.57-0.79RX	1.57	0.79	0.02	0.030	2.80	2.40	1.7		●	0.04-0.08
GIP 2.00-0.15 R/LX	2.00	0.15	0.02	0.030	3.00	2.40	1.7	●		0.05-0.08
GIP 2.39-0.15 RX	2.39	0.15	0.02	0.030	3.50	2.40	1.7	●		0.05-0.09
GIP 2.39-1.19RX	2.39	1.19	0.02	0.050	3.90	2.40	1.7		●	0.06-0.12

• Toolholder seat needs to be modified according to insert profile to ensure clearance. • For cutting speed recommendations and user guide, see pages 380-395

⁽¹⁾ Cutting width tolerance (+/-)

⁽²⁾ Corner radius tolerance (+/-)

For tools, see pages: GHMPR/L (258) • GHMR/L (258)

CUTGRIP

GHMUR/L
External Holders for
45° Undercutting

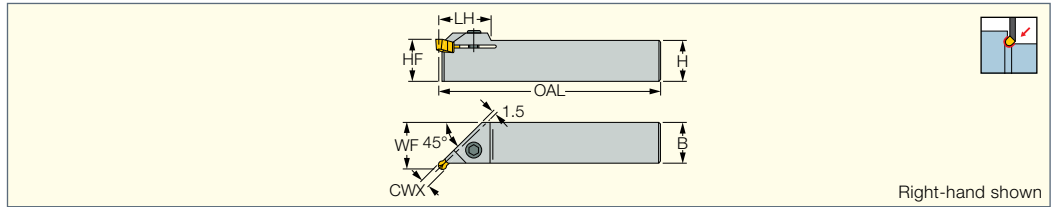

Right-hand shown

Designation	CWX ⁽¹⁾	H	HF	B	OAL	LH	WF		
GHMUR/L 16	4.80	16.0	16.0	16.0	112.00	25.0	19.00	SR M6X16 DIN912	HW 5.0
GHMUR/L 20	6.40	20.0	20.0	20.0	122.00	25.0	23.00	SR M6X16 DIN912	HW 5.0
GHMUR/L 25	6.40	25.0	25.0	25.0	137.00	25.0	28.00	SR M6X16 DIN912	HW 5.0

• For D>100 mm, GIP/GIF inserts can be used (clearance types UN, D or G are not required).

⁽¹⁾ Maximum cutting width

CUTGRIP

GIMY-UN
Utility Single-Ended Inserts,
for External Undercutting

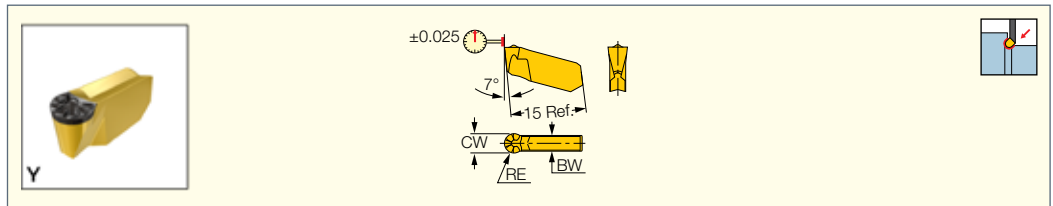

Designation	Dimensions						IC8250	Recommended Machining Data
	CW	RE	CWTOL ⁽¹⁾	RETOL ⁽²⁾	BW	CDX		f groove (mm/rev)
GIMY 315-UN	3.00	1.50	0.05	0.050	2.40	2.00	•	0.05-0.15
GIMY 420-UN	4.00	2.00	0.05	0.050	3.20	2.50	•	0.05-0.15

• For 45° undercutting on D 100 mm, regular GIMY inserts may be used. • For cutting speed recommendations and user guide, see pages 380-395

⁽¹⁾ Cutting width tolerance (+/-)

⁽²⁾ Corner radius tolerance (+/-)

For tools, see pages: GHMUR/L (287)

CUTGRIP

GIP-UN
Precision Double-Ended Inserts
for External Undercutting

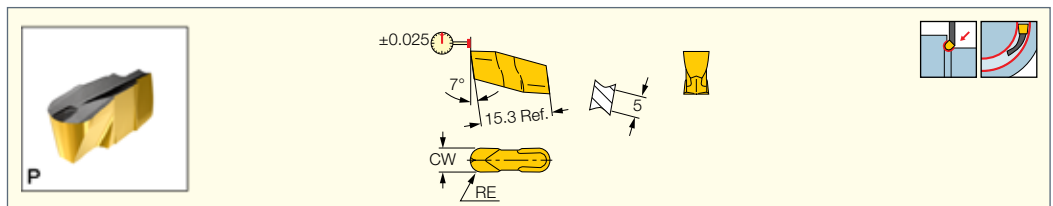

Designation	Dimensions							Tough ← Hard				Recommended Machining Data
	CW	RE	CWTOL ⁽¹⁾	RETOL ⁽²⁾	DMIN	BW	CDX	IC830	IC8250	IC808	IC20	f groove (mm/rev)
GIP 3.00-1.50UN	3.00	1.50	0.05	0.050	35.00	2.40	4.00	•	•	•	•	0.05-0.15
GIP 4.00-2.00UN	4.00	2.00	0.05	0.050	35.00	3.20	4.00	•	•	•	•	0.05-0.15

• Not recommended for turning. • For undercutting at 45° and D100 mm, other GIP inserts apply as well

• For cutting speed recommendations and user guide, see pages 380-395

⁽¹⁾ Cutting width tolerance (+/-)

⁽²⁾ Corner radius tolerance (+/-)

For tools, see pages: C#-GHDR/L (259) • CGHN-DG (267) • CGPAD (265) • CGPAD-JHP (265) • GHDR/L (short pocket) (259) • GHDR/L-JHP (short pocket) (260) • GHDR/L-JHP-MC (short pocket) (261) • GHMPR/L (258) • GHMR/L (258) • GHMUR/L (287)

CUTGRIP

GPV

Precision Inserts for Grooving
Multi V-Ribbed Pulleys

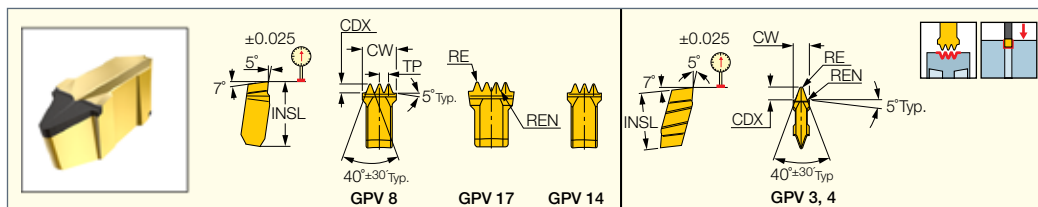

Designation	Dimensions							Tough ↔ Hard			Recommended Machining Data
	CW	TP	CDX	RE	REN	NT	INSL	IC8250	IC5010	IC428	
GPV 3-2.34-1 (1)	2.80	2.34	2.21	0.32	0.20	1	15.30	●	●		0.06-0.15
GPV 4-3.56-1 (1)	4.03	3.56	3.42	0.45	0.30	1	15.30	●	●	●	0.06-0.15
GPV 8-2.34-3 (2)	7.48	2.34	2.21	0.32	0.20	3	15.30	●	●	●	0.06-0.15
GPV 14-2.34-4 (3)	9.82	2.34	2.21	0.32	0.20	4	24.00	●	●	●	0.06-0.15
GPV 14-3.56-3 (3)	11.14	3.56	3.42	0.45	0.30	3	24.00	●	●	●	0.06-0.15
GPV 17-3.56-4 (4)	14.68	3.56	3.42	0.45	0.30	4	24.00	●	●	●	0.06-0.15

• Toolholder seat needs to be modified according to insert profile to ensure clearance. • For cutting speed recommendations and user guide, see pages 380-395

(1) Use holders which are suitable for GIP 3 / GIP 4

(2) Use holders which are suitable for GIMY 808

(3) Use holders which are suitable for TIGER 14

(4) Use holders which are suitable for TIGER 17

For tools, see pages: C#-GHDR/L (259) • CGPAD-JHP (265) • GHDR/L (short pocket) (259) • GHDR/L-JHP (short pocket) (260) • GHDR/L-JHP-MC (short pocket) (261)

• GHDR/L/N 12/14 (319) • GHMPR/L (258) • GHMR/L (258)

CUTGRIP

GDK

Inserts for Rough Grooving
V-Shaped Piston Grooves

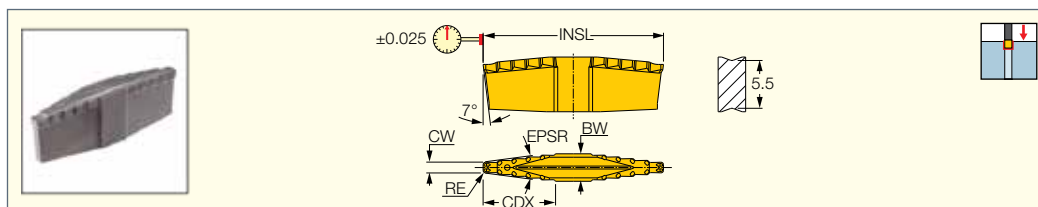

Designation	Dimensions								Tough ↔ Hard		Recommended Machining Data
	CW	RE	CWTOL(2)	RETOL(3)	CDX	EPSR	INSL	BW	IC808	IC908	
GDK 1.5-MS (1)	1.50	0.50	0.02	0.000	8.40	14.0	21.00	3.50	●	●	0.15-0.25
GDK 1.81-MS	1.81	0.50	0.02	0.000	8.40	12.0	19.70	3.50	●		0.15-0.25

• For steel grooves

(1) For steel grooves

(2) Cutting width tolerance (+/-)

(3) Corner radius tolerance (+/-)

CUTGRIP

GDP

Inserts for Precision Grooving
of V-Shaped Piston Grooves

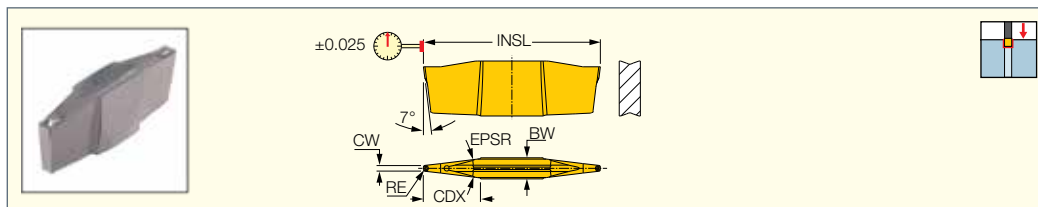

Designation	Dimensions								Tough ↔ Hard		Recommended Machining Data
	CW	RE	CWTOL(1)	RETOL(2)	CDX(3)	EPSR	INSL	BW	IC308	IC908	
GDP 1.20-0.30-4768V2Q	1.20	0.30	0.02	0.000	6.50	11.0	25.00	2.40	●	●	0.12-0.18
GDP 1.55-0.30-1404Q	1.55	0.30	0.02	0.000	6.50	10.0	20.90	3.50		●	0.12-0.18
GDP 1.75-1406Q	1.75	0.30	0.02	0.000	7.50	- (4)	20.95	3.50	●		0.12-0.18

(1) Cutting width tolerance (+/-)

(2) Corner radius tolerance (+/-)

(3) Cutting depth maximum

(4) Left edge 7.17° + right edge 7.83°

HLPGR/L

Tools for L-Type LPGIR/L Inserts

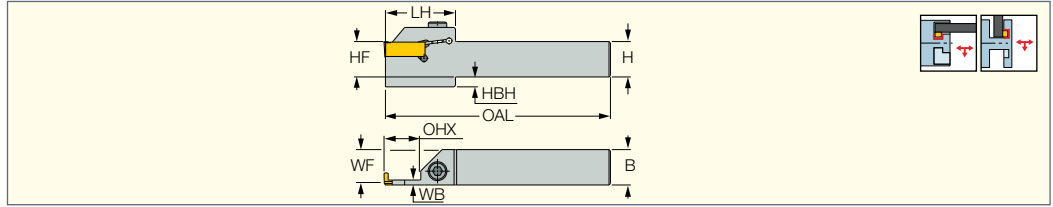

Designation	OHX ⁽¹⁾	H	HF	HBH	B	WB	WF	OAL	LH	Insert		
HLPGR/L 2525-12-A3.5-T25	25.00	25.0	25.0	7.0	25.0	3.50	23.30	160.00	50.0	LPGIR/L 12	SR M6X20 DIN912	HW 5.0
HLPGR/L 3225-12-A3.5-T25	25.00	32.0	32.0	-	25.0	3.50	23.30	160.00	50.0	LPGIR/L 12	SR M6X20 DIN912	HW 5.0
HLPGR/L 2525-12-A4.5-T30	30.00	25.0	25.0	7.0	25.0	4.50	22.80	160.00	55.0	LPGIR/L 12	SR M6X20 DIN912	HW 5.0
HLPGR/L 3225-12-A4.5-T30	30.00	32.0	32.0	-	25.0	4.50	22.80	160.00	55.0	LPGIR/L 12	SR M6X20 DIN912	HW 5.0
HLPGR/L 2525-16-A6-T30	30.00	25.0	25.0	7.0	25.0	6.00	22.00	160.00	55.0	LPGIR/L 16	SR M6X20 DIN912	HW 5.0
HLPGR/L 3225-16-A6-T30	30.00	32.0	32.0	-	25.0	6.00	22.00	160.00	55.0	LPGIR/L 16	SR M6X20 DIN912	HW 5.0

- In case of face penetration prior to radial grooving, please check that the lower insert support is relieved from the groove's outer diameter
- ⁽¹⁾ Cutting depth maximum

For inserts, see pages: LPGIR/L (289)

LPGIR/L

Inserts for Axial Grooves Inside Radial Grooves and for Radial Grooves Inside Axial Grooves

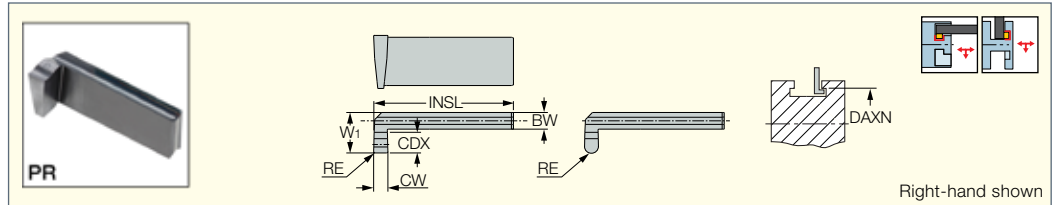

Designation	Dimensions									IC907
	CW	RE	CWTOL ⁽¹⁾	RETOL ⁽²⁾	BW	CDX	INSL	W ₁	DAXN ⁽³⁾	
LPGIR/L 12-8-2T4PR	2.00	0.20	0.02	0.030	4.00	3.50	30.00	8.00	200.0	●
LPGIR/L 12-8-210T4	2.00	1.00	0.02	0.030	4.00	3.50	30.00	8.00	200.0	●
LPGIR/L 12-8.5-3T5PR	3.00	0.30	0.02	0.030	3.50	4.50	30.00	8.50	200.0	●
LPGIR/L 12-8.5-315T5	3.00	1.50	0.02	0.030	3.50	4.50	30.00	8.50	200.0	●
LPGIR/L 12-9.5-4T6PR	4.00	0.40	0.02	0.030	3.50	5.50	30.00	9.50	200.0	●
LPGIR/L 12-9.5-420T6	4.00	2.00	0.02	0.030	3.50	5.50	30.00	9.50	200.0	●
LPGIR/L 12-11-5T6.5PR	5.00	0.40	0.02	0.030	4.50	6.00	30.00	11.00	200.0	●
LPGIR/L 12-11-525T6.5	5.00	2.50	0.02	0.030	4.50	6.00	30.00	11.00	200.0	●
LPGIR/L 16-15.5-3T9PR	3.00	0.30	0.02	0.030	6.00	8.50	30.60	15.50	200.0	●
LPGIR/L 16-15.5-315T9	3.00	1.50	0.02	0.030	6.00	8.50	30.60	15.50	200.0	●
LPGIR/L 16-15.5-4T9PR	4.00	0.40	0.02	0.030	6.00	8.50	30.60	15.50	200.0	●
LPGIR/L 16-15.5-420T9	4.00	2.00	0.02	0.030	6.00	8.50	30.60	15.50	200.0	●
LPGIR/L 16-15.5-5T9PR	5.00	0.40	0.02	0.030	6.00	8.50	30.60	15.50	200.0	●
LPGIR/L 16-15.5-525T9	5.00	2.50	0.02	0.030	6.00	8.50	30.60	15.50	200.0	●

- For cutting speed recommendations and user guide, see pages 380-395
- ⁽¹⁾ Cutting width tolerance (+/-)
- ⁽²⁾ Corner radius tolerance (+/-)
- ⁽³⁾ Minimum axial grooving diameter

For tools, see pages: HLPGR/L (289)

ISCAR**THREAD**

CUTGRIP

TIP-WT

Precision Ground Double-Ended Threading Inserts with a 55° Partial Profile and a Chipformer

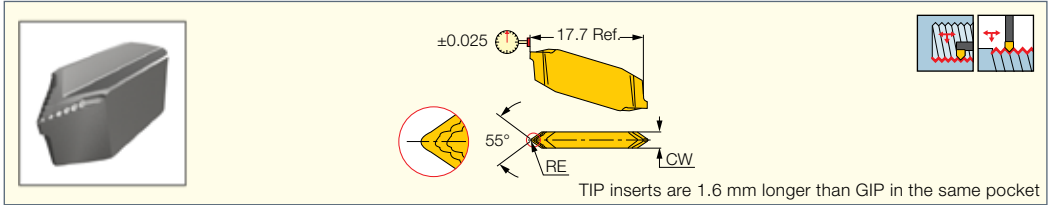

Designation	Dimensions					Tough ↔ Hard	
	CW	RE	RETOL ⁽²⁾	TPIX ⁽³⁾	TPIN ⁽⁴⁾	IC08	IC908
TIP 2WT-0.05 ⁽¹⁾	2.40	0.05	0.030	54.00	6.40	●	●
TIP 4WT-0.15 ⁽¹⁾	4.00	0.15	0.030	19.00	6.40	●	●
TIP 5WT-0.25 ⁽¹⁾	5.50	0.25	0.030	12.00	6.40	●	●

• Toolholder seat needs to be modified according to insert profile to ensure clearance • Pitch max 0.187xD

⁽¹⁾ TPIN(thread per inch minimum) = D/6.4 • D-Diameter of thread (inch)

⁽²⁾ Corner radius tolerance (+/-)

⁽³⁾ Threads per inch maximum

⁽⁴⁾ Threads per inch minimum

For tools, see pages: C#-GHDR/L (259) • CGHN 26-M (340) • CGHN 32-DGM (342) • CGHN 32-M (341) • CGHN-D (266) • CGHN-DG (267) • CGHN-S (266) • CGPAD (265) • CGPAD-JHP (265) • GHDR/L (short pocket) (259) • GHDR/L-JHP (short pocket) (260) • GHDR/L-JHP-MC (short pocket) (261) • GHGR/L (262) • GHMPR/L (258) • GHMR/L (258) • GHSR/L (357) • GHSR/L-JHP-SL (358)

ISCAR**THREAD**

CUTGRIP

TIP-MT

Precision Ground Double-Ended Threading Inserts with a 60° Partial Profile and Chipformer

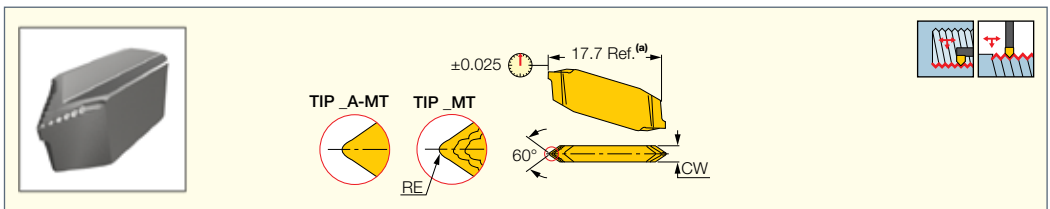

Designation	Dimensions					Tough ↔ Hard	
	CW	RE	RETOL ⁽²⁾	TPN ⁽³⁾	TPIX ⁽⁴⁾	IC08	IC908
TIP 2A-MT-0.05 ⁽¹⁾	2.40	0.05	0.030	0.450	56.00		●
TIP 2MT-0.05	2.40	0.05	0.030	0.450	56.00	●	●
TIP 2MT-0.14	2.40	0.14	0.030	1.110	23.00	●	●
TIP 4A-MT-0.15 ⁽¹⁾	4.00	0.15	0.030	1.250	20.00		●
TIP 4MT-0.15	4.00	0.15	0.030	1.250	20.00		●
TIP 4MT-0.20	4.00	0.20	0.030	1.630	16.00	●	●
TIP 5MT-0.25	5.50	0.25	0.030	1.940	13.00	●	●

• (a) TIP inserts are 1.6 mm longer than GIP in the same pocket • Toolholder seat needs to be modified according to insert profile to ensure clearance

⁽¹⁾ Without chipformer (flat rake)

⁽²⁾ Corner radius tolerance (+/-)

⁽³⁾ Thread pitch minimum (mm)

⁽⁴⁾ Threads per inch maximum

For tools, see pages: C#-GHDR/L (259) • CGHN 26-M (340) • CGHN 32-DGM (342) • CGHN 32-M (341) • CGHN-D (266) • CGHN-DG (267) • CGHN-S (266) • CGPAD (265) • CGPAD-JHP (265) • GHDR/L (short pocket) (259) • GHDR/L-JHP (short pocket) (260) • GHDR/L-JHP-MC (short pocket) (261) • GHGR/L (262) • GHMPR/L (258) • GHMR/L (258) • GHSR/L (357) • GHSR/L-JHP-SL (358)

TIP-P-ISO

Precision Ground ISO
Metric Full Profile Double-
Ended External Threading
Inserts with a Chipformer

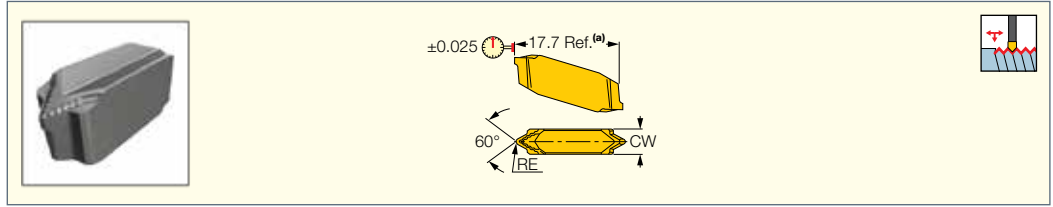

Designation	Dimensions				Tough ← Hard	
	TP	CW	RE	RETOL ⁽¹⁾	IC08	IC908
TIP 2P0.5-ISO	0.500	2.40	0.08	0.030	●	●
TIP 2P0.75-ISO	0.750	2.40	0.11	0.030	●	●
TIP 2P0.8-ISO	0.800	2.40	0.12	0.030	●	●
TIP 2P1.0-ISO	1.000	2.40	0.14	0.030	●	●
TIP 2P1.25-ISO	1.250	2.40	0.18	0.030	●	●
TIP 2P1.5-ISO	1.500	2.40	0.22	0.030	●	●
TIP 2P1.75-ISO	1.750	2.40	0.25	0.030	●	●
TIP 4P2.0-ISO	2.000	4.00	0.28	0.030	●	●
TIP 4P2.5-ISO	2.500	4.00	0.35	0.050	●	●
TIP 4P3.0-ISO	3.000	4.00	0.42	0.050		●
TIP 4P3.5-ISO	3.500	4.00	0.48	0.050		●
TIP 5P4.0-ISO	4.000	5.50	0.55	0.050		●
TIP 5P5.0-ISO	5.000	5.50	0.68	0.050		●

• (a) TIP inserts are 1.6 mm longer than GIP in the same pocket • Toolholder seat needs to be modified according to insert profile to ensure clearance

⁽¹⁾ Thread pitch

For tools, see pages: C#-GHDR/L (259) • CGHN-D (266) • CGHN-DG (267) • CGHN-S (266) • CGPAD (265) • CGPAD-JHP (265) • GHDR/L (short pocket) (259)
• GHDR/L-JHP (short pocket) (260) • GHDR/L-JHP-MC (short pocket) (261) • GHGR/L (262) • GHMPR/L (258) • GHMR/L (258) • GHSR/L (357) • GHSR/L-JHP-SL (358)

TIP-P-UN

American UN (UNC,UNF,UNEF)
Precision Ground External Double-
Ended Full Profile Threading
Inserts with a Chipformer

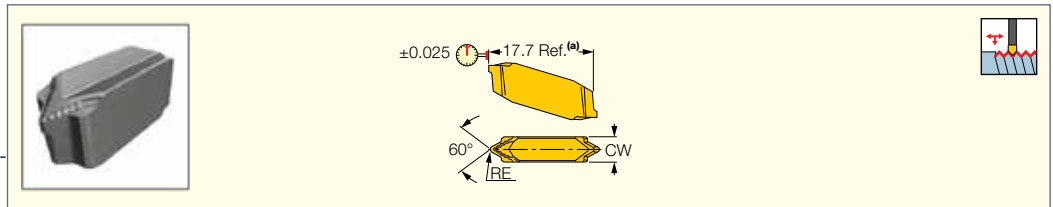

Designation	Dimensions				Tough ← Hard		
	CW	RE	RETOL ⁽¹⁾	TPI	IC08	IC808	IC908
TIP 2P32-UN	2.40	0.10	0.030	32.0	●		●
TIP 2P28-UN	2.40	0.11	0.030	28.0	●		●
TIP 2P24-UN	2.40	0.13	0.030	24.0	●		●
TIP 2P20-UN	2.40	0.16	0.030	20.0	●		●
TIP 2P18-UN	2.40	0.18	0.030	18.0	●		●
TIP 2P16-UN	2.40	0.20	0.030	16.0	●		●
TIP 2P14-UN	2.40	0.23	0.030	14.0	●		●
TIP 2P13-UN	2.40	0.25	0.030	13.0	●		●
TIP 2P12-UN	2.40	0.27	0.030	12.0	●		●
TIP 4P11-UN	4.00	0.30	0.030	11.0			●
TIP 4P10-UN	4.00	0.33	0.050	10.0		●	●
TIP 4P08-UN	4.00	0.41	0.050	8.0			●

• (a) TIP inserts are 1.6 mm longer than GIP in the same pocket • Toolholder seat needs to be modified according to insert profile to ensure clearance

⁽¹⁾ Corner radius tolerance (+/-)

For tools, see pages: C#-GHDR/L (259) • CGHN-D (266) • CGHN-DG (267) • CGHN-S (266) • CGPAD (265) • CGPAD-JHP (265) • GHDR/L (short pocket) (259)
• GHDR/L-JHP (short pocket) (260) • GHDR/L-JHP-MC (short pocket) (261) • GHGR/L (262) • GHMPR/L (258) • GHMR/L (258) • GHSR/L (357) • GHSR/L-JHP-SL (358)

ISCAR THREAD

CUTGRIP

TIP-P-BSW

American (BSW, BSF, BSP)
Precision Ground External
Double-Ended Full Profile
Threading Inserts with a Chipformer

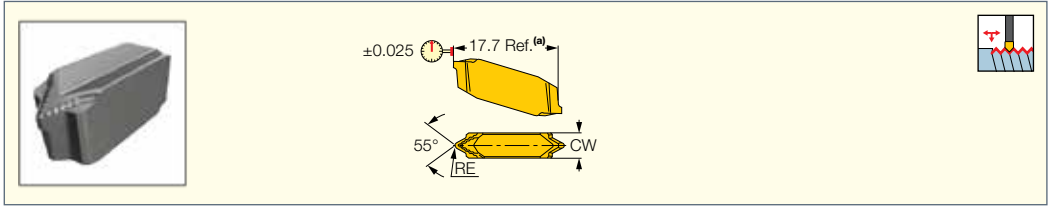

Designation	Dimensions			Tough ↔ Hard	
	CW	RE	TPI	IC08	IC908
TIP 2P28-BSW	2.40	0.11	28.0	●	●
TIP 2P26-BSW	2.40	0.12	26.0	●	●
TIP 2P-24BSW	2.40	0.12	24.0	●	●
TIP 2P24-BSW	2.40	0.12	24.0	●	●
TIP 2P-20BSW	2.40	0.16	20.0	●	●
TIP 2P20-BSW	2.40	0.16	20.0	●	●
TIP 2P19-BSW	2.40	0.16	19.0	●	●
TIP 2P-18BSW	2.40	0.17	18.0	●	●
TIP 2P18-BSW	2.40	0.17	18.0	●	●
TIP 2P-16BSW	2.40	0.19	16.0	●	●
TIP 2P16-BSW	2.40	0.19	16.0	●	●
TIP 2P14-BSW	2.40	0.22	14.0	●	●
TIP 4P12-BSW	4.00	0.25	12.0	●	●
TIP 4P11-BSW	4.00	0.28	11.0	●	●
TIP 4P10-BSW	4.00	0.31	10.0	●	●

• (a) TIP inserts are 1.6 mm longer than GIP in the same pocket • Toolholder seat needs to be modified according to insert profile to ensure clearance
For tools, see pages: C#-GHDR/L (259) • CGHN-D (266) • CGHN-DG (267) • CGHN-S (266) • CGPAD (265) • CGPAD-JHP (265) • GHDR/L (short pocket) (259)
 • GHDR/L-JHP (short pocket) (260) • GHDR/L-JHP-MC (short pocket) (261) • GHGR/L (262) • GHMPR/L (258) • GHMR/L (258) • GHSR/L (357) • GHSR/L-JHP-SL (358)

ISCAR THREAD

CUTGRIP

TIP-P-NPT

NPT (National Pipe Threads)
Precision Ground Double-Ended
External Full Profile Threading
Inserts with a Chipformer

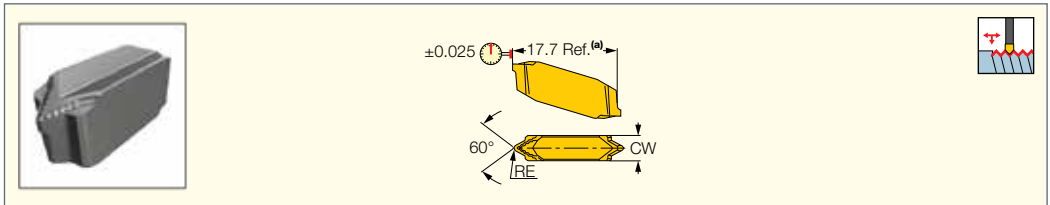

Designation	Dimensions				Tough ↔ Hard	
	CW	RE	RETOL ⁽¹⁾	TPI ⁽²⁾	IC08	IC908
TIP 2P27-NPT	2.40	0.05	0.030	27.0	●	●
TIP 2P18-NPT	2.40	0.07	0.030	18.0	●	●
TIP 2P14-NPT	2.40	0.09	0.030	14.0	●	●
TIP 4P11.5-NPT	4.00	0.10	0.030	11.5	●	●
TIP 4P8-NPT	4.00	0.13	0.030	8.0	●	●

• (a) TIP inserts are 1.6 mm longer than GIP in the same pocket • Toolholder seat needs to be modified according to insert profile to ensure clearance

⁽¹⁾ Corner radius tolerance (+/-)

⁽²⁾ Threads per inch

For tools, see pages: C#-GHDR/L (259) • CGHN-D (266) • CGHN-DG (267) • CGHN-S (266) • CGPAD (265) • CGPAD-JHP (265) • GHDR/L (short pocket) (259)
 • GHDR/L-JHP (short pocket) (260) • GHDR/L-JHP-MC (short pocket) (261) • GHGR/L (262) • GHMPR/L (258) • GHMR/L (258) • GHSR/L (357) • GHSR/L-JHP-SL (358)

TIP-P-BSPT

Precision Ground BSPT (British Standard Pipe) External Double-Ended Full Profile Threading Inserts with a Chipformer

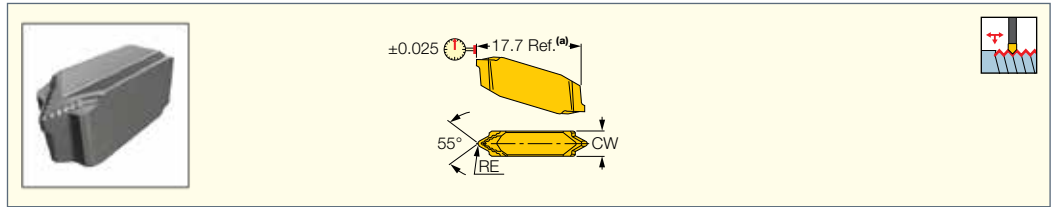

Designation	Dimensions				Tough ↔ Hard	
	CW	RE	RETOL ⁽¹⁾	TPI ⁽²⁾	IC08	IC908
TIP 2P28-BSPT	2.40	0.11	0.030	28.0	●	●
TIP 2P19-BSPT	2.40	0.16	0.030	19.0	●	●
TIP 2P14-BSPT	2.40	0.22	0.030	14.0	●	●
TIP 4P11-BSPT	4.00	0.28	0.030	11.0	●	●

• (a) TIP inserts are 1.6 mm longer than GIP in the same pocket • Toolholder seat needs to be modified according to insert profile to ensure clearance

⁽¹⁾ Corner radius tolerance (+/-)

⁽²⁾ Threads per inch

For tools, see pages: C#-GHDR/L (259) • CGHN-D (266) • CGHN-DG (267) • CGHN-S (266) • CGPAD (265) • CGPAD-JHP (265) • GHDR/L (short pocket) (259) • GHDR/L-JHP (short pocket) (260) • GHDR/L-JHP-MC (short pocket) (261) • GHGR/L (262) • GHMPR/L (258) • GHMR/L (258) • GHSR/L (357) • GHSR/L-JHP-SL (358)

PHGR/L

Holders for External Grooving and Turning

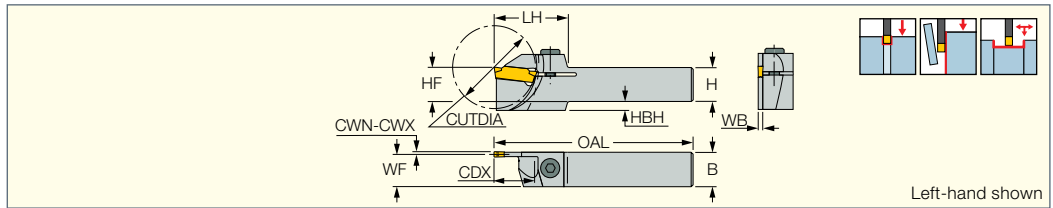

Designation	CWN ⁽¹⁾	CWX ⁽²⁾	CUTDIA ⁽³⁾	CDX ⁽⁴⁾	H	HF	B	OAL	LH	WF	HBH	WB	Insert		
PHGR/L 20-2.4	2.40	3.18	34.0	17.00	20.0	20.0	20.0	120.00	33.0	19.10	-	1.90	GDMW 2.4	SR M5X16 DIN912	HW 4.0
PHGR/L 25-2.4	2.40	3.18	34.0	17.00	25.0	25.0	25.0	140.00	33.0	24.10	-	1.90	GDMW 2.4	SR M5X16 DIN912	HW 4.0
PHGR/L 16-2.4	2.40	3.18	34.0	17.00	16.0	16.0	16.0	110.00	33.0	15.10	5.5	1.90	GDMW 2.4	SR M5X16 DIN912	HW 4.0

• For user guide, see pages 380-395

⁽¹⁾ Minimum cutting width

⁽²⁾ Maximum cutting width

⁽³⁾ Maximum parting diameter.

⁽⁴⁾ Cutting depth maximum

PHAR/L

External Machining Holders for PADR/L Adapters

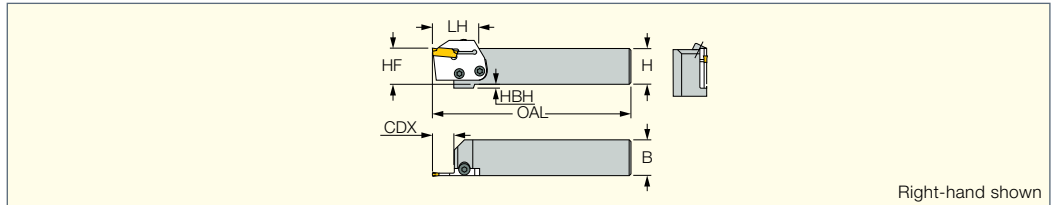

Designation	CDX ⁽¹⁾	H	HF	B	OAL	HBH	Adapter ⁽²⁾				
PHAR/L 20	16.30	20.0	20.0	20.0	140.00	10.0	PADR/L 2.4	SR 76-1368	HW 4.0	SR M5-04451	T-20/5
PHAR/L 25	16.30	25.0	25.0	25.0	140.00	5.0	PADR/L 2.4	SR 76-1368	HW 4.0	SR M5-04451	T-20/5

⁽¹⁾ Cutting depth maximum

⁽²⁾ Adapters to be ordered separately.

CUTGRIP

PADR/L

Adapters for GDMW/GDMY
Groove-Turn Inserts

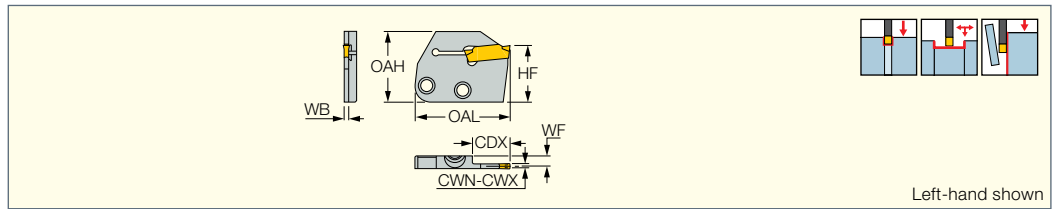

Designation	CWN ⁽¹⁾	CWX ⁽²⁾	CDX	OAL	WB	HF	OAH	WF	Insert
PADR/L 2.4	2.40	3.18	16.30	41.00	1.90	24.0	30.0	4.20	GDMW 2.4

• For user guide, see pages 380-395

⁽¹⁾ Minimum cutting width

⁽²⁾ Maximum cutting width

For inserts, see pages: GDMW 2.4 (294)

For holders, see pages: PHAR/L (293)

CUTGRIP

GDMW 2.4

Utility Double-Ended
Inserts for External Turning,
Grooving and Parting

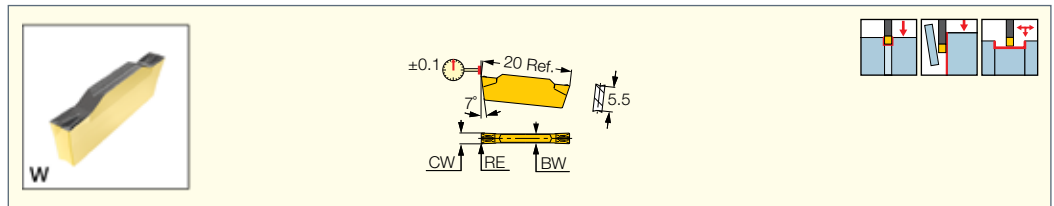

Designation	Dimensions						Tough ↔ Hard					Recommended Machining Data		
	CW	RE	CWTOL ⁽¹⁾	RETOL ⁽²⁾	BW	CDX	IC830	IC808	IC908	IC20	IC20N	a ₀ (mm)	f turn (mm/rev)	f groove (mm/rev)
GDMW 2.4	2.40	0.18	0.04	0.030	2.00	18.00	●	●	●	●	●	0.25-1.50	0.07-0.12	0.05-0.08

• For cutting speed recommendations and user guide, see pages 380-395

⁽¹⁾ Cutting width tolerance (+/-)

⁽²⁾ Corner radius tolerance (+/-)

For tools, see pages: PADR/L (294) • PHGR/L (293) • PHSR/L (357)

PCHRS/LS-17

Tools Carrying Inserts with 5
Cutting Edges for Grooving,
Parting and Recessing
Next to High Shoulders

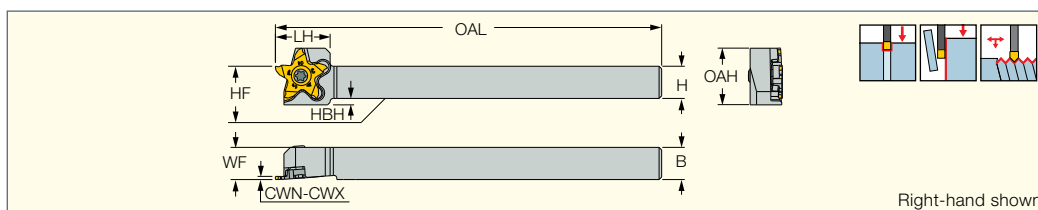



Designation	H	B	CWN ⁽¹⁾	CWX ⁽²⁾	WF	OAL	LH	HBH	OAH	HF
PCHR/LS 10-17	10.0	10.0	0.25	3.18	10.00	120.00	17.0	2.0	17.6	10.0
PCHR/LS 12-17	12.0	12.0	0.25	3.18	12.00	120.00	17.0	-	17.6	12.0
PCHR/LS 16-17	16.0	16.0	0.25	3.18	16.00	120.00	17.0	-	21.6	16.0
PCHR/LS 20-17	20.0	20.0	0.25	3.18	20.00	120.00	17.0	-	25.6	20.0

• Use right-hand inserts on right-hand tools and vice versa

⁽¹⁾ Minimum cutting width

⁽²⁾ Maximum cutting width

Spare Parts

Designation		
PCHLS 10-17	SR M4-39432	T-1508/5
PCHRS 10-17	SR M4-39432L	T-1508/5
PCHLS 12-17	SR M4-39432	T-1508/5
PCHRS 12-17	SR M4-39432L	T-1508/5
PCHLS 16-17	SR M4-39432	T-1508/5
PCHRS 16-17	SR M4-39432L	T-1508/5
PCHLS 20-17	SR M4-39432	T-1508/5
PCHRS 20-17	SR M4-39432L	T-1508/5

PENTA 17-P-RS/LS

Pentagonal Inserts for Grooving
and Parting Soft Materials,
Thin and Miniature Parts

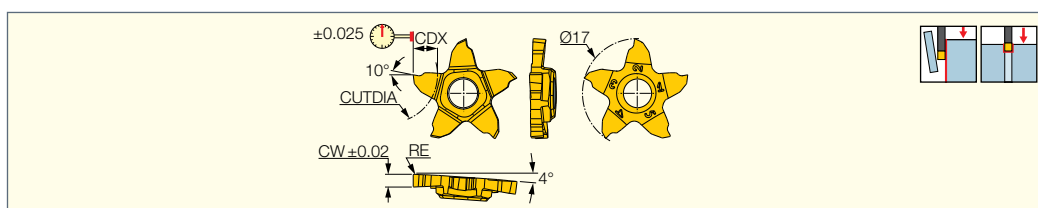

Designation	Dimensions					IC1008	Recommended Machining Data
	CW	RE	CDX	CUTDIA	f groove (mm/rev)		
PENTA 17N025P000R/LS	0.25	0.00	0.60	1.2	●	0.02-0.03	
PENTA 17N030P000R/LS	0.30	0.00	0.60	1.2	●	0.02-0.03	
PENTA 17N033P000R/LS	0.33	0.00	0.60	1.2	●	0.02-0.03	
PENTA 17N043P000R/LS	0.43	0.00	1.00	2.0	●	0.02-0.04	
PENTA 17N050P000R/LS	0.50	0.00	2.00	4.0	●	0.02-0.04	
PENTA 17N075P000R/LS	0.75	0.00	2.50	5.0	●	0.02-0.04	
PENTA 17N080P000R/LS	0.80	0.00	2.50	5.0	●	0.02-0.04	
PENTA 17N095P000R/LS	0.95	0.00	3.00	6.0	●	0.02-0.05	
PENTA 17N100P010R/LS	1.00	0.10	3.00	6.0	●	0.02-0.05	
PENTA 17N120P010R/LS	1.20	0.10	3.00	6.0	●	0.02-0.05	
PENTA 17N140P010R/LS	1.40	0.10	3.00	6.0	●	0.02-0.05	
PENTA 17N150P010R/LS	1.50	0.10	4.00	8.0	●	0.02-0.07	
PENTA 17N157P010R/LS	1.57	0.10	4.00	8.0	●	0.02-0.07	
PENTA 17N170P010R/LS	1.70	0.10	4.00	8.0	●	0.02-0.07	
PENTA 17N178P010R/LS	1.78	0.10	4.00	8.0	●	0.02-0.07	
PENTA 17N196P010R/LS	1.96	0.10	4.00	8.0	●	0.02-0.08	
PENTA 17N200P010R/LS	2.00	0.10	4.00	8.0	●	0.02-0.08	
PENTA 17N222P010R/LS	2.22	0.10	4.00	8.0	●	0.02-0.08	
PENTA 17N230P010R/LS	2.30	0.10	4.00	8.0	●	0.02-0.08	
PENTA 17N239P010R/LS	2.39	0.10	4.00	8.0	●	0.02-0.08	
PENTA 17N247P010R/LS	2.47	0.10	4.00	8.0	●	0.02-0.08	
PENTA 17N250P010R/LS	2.50	0.10	4.00	8.0	●	0.02-0.08	
PENTA 17N270P010R/LS	2.70	0.10	4.00	8.0	●	0.02-0.09	
PENTA 17N287P010R/LS	2.87	0.10	4.00	8.0	●	0.02-0.10	
PENTA 17N300P010R/LS	3.00	0.10	4.00	8.0	●	0.02-0.10	
PENTA 17N318P010R/LS	3.18	0.10	4.00	8.0	●	0.02-0.10	

• For cutting speed recommendations and user guide, see pages 380-395

For tools, see pages: PCHRS/LS-17 (295)



PENTA 17-NP-RS/LS
 Pentagonal Inserts for Precision Grooving and Turning Next to High Shoulder Applications

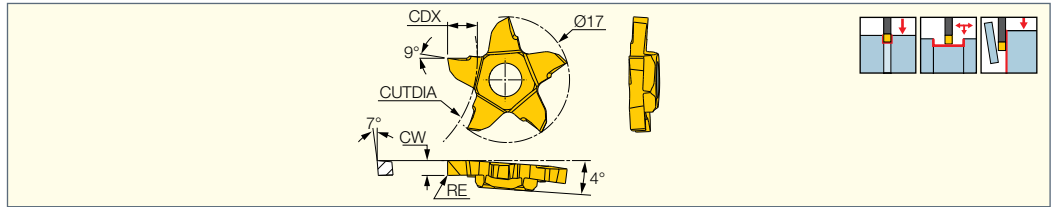

Designation	Dimensions				IC1008	Recommended Machining Data		
	CW	RE	CDX	CUTDIA		a_p (mm)	f turn (mm/rev)	f groove (mm/rev)
PENTA 17-100NP08R/LS	1.00	0.08	3.00	32.0	●	0.05-0.70	0.02-0.06	0.03-0.06
PENTA 17-200NP08R/LS	2.00	0.08	4.00	32.0	●	0.05-2.50	0.05-0.15	0.05-0.09
PENTA 17-300NP08R/LS	3.00	0.08	4.00	32.0	●	0.05-3.10	0.05-0.19	0.05-0.11

• When turning to the opposite side of chipformer, maximum CDX is 0.5 mm • For cutting speed recommendations and user guide, see pages 380-395
 For tools, see pages: PCHRS/LS-17 (295)

Designation	Dimensions			CUTDIA as a function of depth of cut (CDX)				
	CW	RE	CDX	CDX ≤ 2.5	CDX ≤ 3.0	CDX ≤ 3.5	CDX ≤ 3.8	CDX ≤ 4.0
PENTA 17-100NP08-L/RS	1.00	0.08	3.00	N.L.	100	-	-	-
PENTA 17-200NP08-L/RS	2.00	0.08	4.00	N.L.	100	75	45	32
PENTA 17-300NP08-L/RS	3.00	0.08	4.00	N.L.	100	75	45	32



PENTA 17-ER/EL
 Back Turning Pentagonal Inserts for Short Chipping Materials

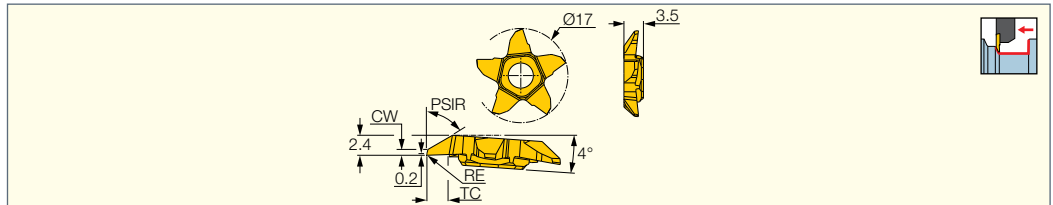

Designation	Dimensions				IC1008	Recommended Machining Data	
	CW	RE	PSIR	Tc		a_p (mm)	f turn (mm/rev)
PENTA 17EL00-07K0LS	0.70	0.00	60.0	4.0	●	0.05-2.50	0.01-0.15
PENTA 17ER00-07K0RS	0.70	0.00	60.0	4.0	●	0.05-2.50	0.01-0.15
PENTA 17EL08-07K0LS	0.70	0.08	60.0	4.0	●	0.05-2.50	0.01-0.15
PENTA 17ER08-07K0RS	0.70	0.08	60.0	4.0	●	0.05-2.50	0.01-0.15

• For cutting speed recommendations and user guide, see pages 380-395
 For tools, see pages: PCHRS/LS-17 (295)



PENTA 17-MT-RS/LS
 Precision Ground Pentagonal External Threading Inserts with a 60° Partial Profile

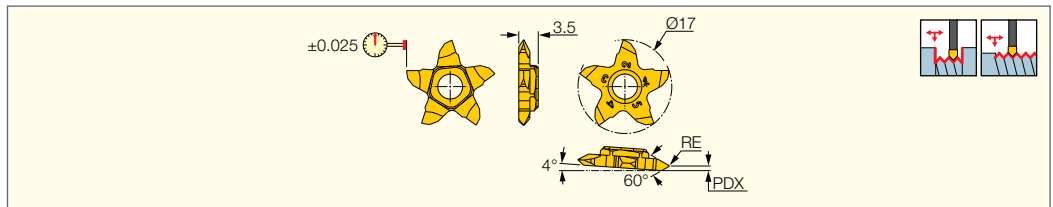

Designation	Dimensions				IC1008
	TPN ⁽¹⁾	TPX ⁽²⁾	RE	PDX	
PENTA 17-MTL003LS	0.300	1.750	0.03	0.8	●
PENTA 17-MTR003RS	0.300	1.750	0.03	0.8	●
PENTA 17-MTL008LS	0.700	3.500	0.08	1.4	●
PENTA 17-MTR008RS	0.700	3.500	0.08	1.4	●

⁽¹⁾ Thread pitch minimum (mm)
⁽²⁾ Thread pitch maximum (mm)

For tools, see pages: PCHRS/LS-17 (295)

PENTA 17-WT-RS/LS
Precision Ground Pentagonal
External Threading Inserts
with a 55° Partial Profile

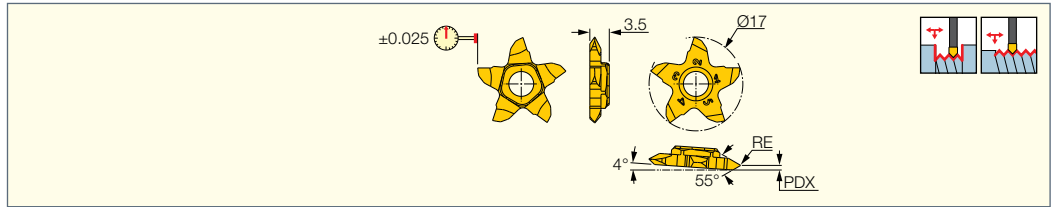

Designation	Dimensions				IC1008
	TPIX ⁽¹⁾	TPIN ⁽²⁾	RE	PDX	
PENTA 17-WTL003LS	72.00	17.00	0.03	0.8	●
PENTA 17-WTR003RS	72.00	17.00	0.03	0.8	●
PENTA 17-WTL008LS	31.00	7.00	0.08	1.4	●
PENTA 17-WTR008RS	31.00	7.00	0.08	1.4	●

⁽¹⁾ Threads per inch maximum
⁽²⁾ Threads per inch minimum

For tools, see pages: PCHRS/LS-17 (295)

PCHR/L-24
Grooving, Parting and
Recessing Holders Carrying
Inserts with 5 Cutting Edges

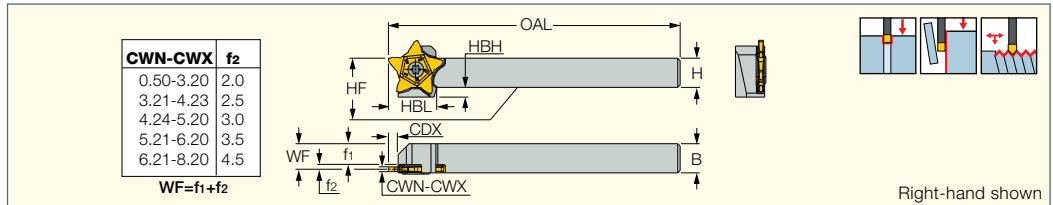

Designation	H	HF	B	CWN ⁽²⁾	CWX ⁽³⁾	f ₁	CDX ⁽⁴⁾	OAL	LH	HBH		
PCHR/L 10-24	10.0	10.0	10.0	0.50	3.20	6.5	6.50	120.00	19.5	6.0	SR 16-212-01397L	T-2010/5
PCHR/L 12-24	12.0	12.0	12.0	0.50	3.20	8.5	6.50	120.00	19.5	4.0	SR 16-212-01397L	T-2010/5
PCHR/L 16-24	16.0	16.0	16.0	0.50	3.20	12.5	6.50	120.00	19.5	-	SR 16-212-01397L	T-2010/5
PCHR/L 20-24	20.0	20.0	20.0	0.50	3.20	16.5	6.50	120.00	19.5	-	SR 16-212-01397L	T-2010/5
PCHR/L 25-24	25.0	25.0	25.0	0.50	3.20	21.5	6.50	135.00	19.5	-	SR 16-212-01397L	T-2010/5
PCHR/L 16-24-5	16.0	16.0	16.0	3.21	5.20	11.5	6.40	120.00	21.5	4.0	SR PCHL-8-06642	T-15/5
PCHR/L 20-24-5	20.0	20.0	20.0	3.21	5.20	15.5	6.40	120.00	21.5	-	SR PCHL-8-06642	T-15/5
PCHR/L 25-24-5	25.0	25.0	25.0	3.21	5.20	20.5	6.40	135.00	21.5	-	SR PCHL-8-06642	T-15/5
PCHR/L 25-24-8 ⁽¹⁾	25.0	25.0	25.0	5.21	8.20	18.5	6.50	135.00	19.5	-	SR PCHL-8-06642	T-15/5

• WF=f₁+f₂ (according to insert width (CW) being used)
⁽¹⁾ Used with special inserts only
⁽²⁾ Minimum cutting width
⁽³⁾ Maximum cutting width
⁽⁴⁾ For specific information, refer to insert data



PCHR/L-24-JHP
Grooving, Parting and Recessing Tools Carrying PENTA Inserts with Channels for High Pressure Coolant

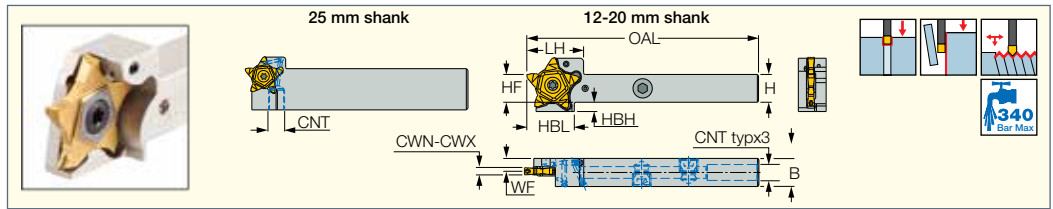

Designation	H	HF	B	CWN ⁽¹⁾	CWX ⁽²⁾	CDX ⁽³⁾	WF	OAL	LH	HBL	HBH	CNT	Insert
PCHR/L 12-24-JHP	12.0	12.0	12.0	0.50	3.20	6.50	5.50	100.00	24.5	20.50	4.0	UNF 5/16-24	PENTA 24
PCHR/L 16-24-JHP	16.0	16.0	16.0	0.50	3.20	6.50	9.50	120.00	24.5	-	-	UNF 5/16-24	PENTA 24
PCHR/L 20-24-JHP	20.0	20.0	20.0	0.50	3.20	6.50	13.50	135.00	24.5	-	-	G 1/8-28	PENTA 24
PCHR/L 25-24-JHP	25.0	25.0	25.0	0.50	3.20	6.50	18.50	135.00	24.5	-	-	G 1/8-28	PENTA 24

- For user guide and accessories see pages 380-400
- ⁽¹⁾ Minimum cutting width
- ⁽²⁾ Maximum cutting width • Up to 6.2 mm width may be ordered on request.
- ⁽³⁾ For specific information, refer to insert data.

Flow Rate vs. Pressure

Designation	70 Bar Flow Rate (liters/min)	100 Bar Flow Rate (liters/min)	140 Bar Flow Rate (liters/min)
PCHR/L 12-24-	5-8	9-11	11-13
PCHR/L 16/20/25-	12-14	14-16	16-18

Coolant Holes

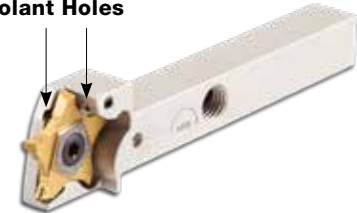

(2) Grooving Depth CDX Relative to CUTDIA

CDX	3.5	4	4.5	5
Dmax	No-limit	210	135	50

Cut-off to Center

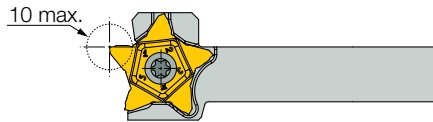

Groove Capacity

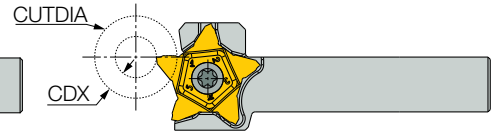

Spare Parts

Designation				
PCHL 12-24-JHP	SR 16-212-01397L-L8.5	T-2010/5	SR 5/16UNF TL360	HW 5/32"
PCHR 12-24-JHP	SR 16-212-01397-L8.5	T-2010/5	SR 5/16UNF TL360	HW 5/32"
PCHL 16-24-JHP	SR 16-212-01397L	T-2010/5	SR 5/16UNF TL360	HW 5/32"
PCHR 16-24-JHP	SR 16-212-01397	T-2010/5	SR 5/16UNF TL360	HW 5/32"
PCHL 20-24-JHP	SR 16-212-01397L	T-2010/5	PLUG G1/8-6.5 TL360	HW 5.0
PCHR 20-24-JHP	SR 16-212-01397	T-2010/5	PLUG G1/8-6.5 TL360	HW 5.0
PCHL 25-24-JHP	SR 16-212-01397L	T-2010/5		
PCHR 25-24-JHP	SR 16-212-01397	T-2010/5		



PCHR/L-24-JHP-MC
Grooving, Parting and Recessing Tools Carrying PENTA Inserts with Bottom Inlets for High Pressure Coolant

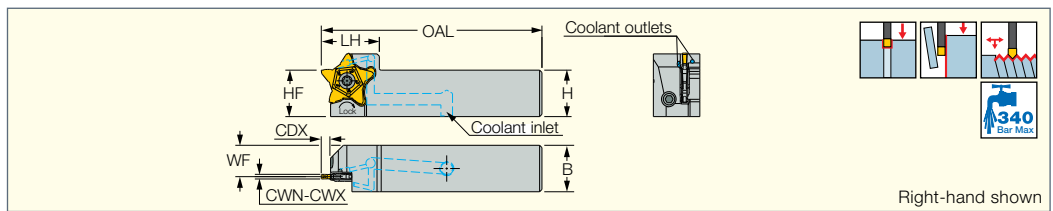

Designation	H	HF	B	CWN ⁽¹⁾	CWX ⁽²⁾	CDX ⁽³⁾	WF	OAL	LH	Insert
PCHR/L 20-24-JHP-MC	20.0	20.0	20.0	0.50	3.20	6.50	13.50	95.00	25.0	PENTA 24
PCHR/L 25-24-JHP-MC	25.0	25.0	25.0	0.50	3.20	6.50	18.50	110.00	25.0	PENTA 24

- For user guide and accessories see pages 380-400
- ⁽¹⁾ Minimum cutting width
- ⁽²⁾ Maximum cutting width • Up to 6.2 mm width may be ordered on request.
- ⁽³⁾ For specific information, refer to insert data.

Spare Parts

Designation		
PCHL 20-24-JHP-MC	SR 16-212-01397L	T-2010/5
PCHR 20-24-JHP-MC	SR 16-212-01397	T-2010/5
PCHL 25-24-JHP-MC	SR 16-212-01397L	T-2010/5
PCHR 25-24-JHP-MC	SR 16-212-01397	T-2010/5

PCHRS/LS

Holders Carrying Inserts with 5 Cutting Edges for Grooving, Parting and Recessing Next to High Shoulders

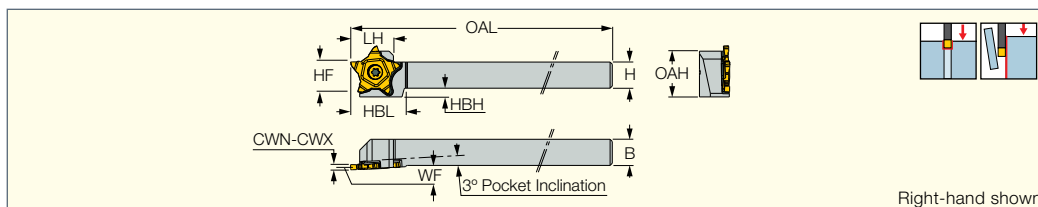

Designation	H	B	CWN ⁽¹⁾	CWX ⁽²⁾	OAL	LH	HBL	HBH	OAH	HF		
PCHR/LS 12-24	12.0	12.0	0.80	4.80	120.00	19.5	24.50	4.0	21.0	999.0	SR 16-212-01397LS	T-2010/5
PCHR/LS 16-24	16.0	16.0	0.80	4.80	120.00	19.5	-	-	21.0	999.0	SR 16-212-01397LS	T-2010/5
PCHR/LS 20-24	20.0	20.0	0.80	4.80	120.00	19.5	-	-	25.0	999.0	SR 16-212-01397LS	T-2010/5
PCHR/LS 25-24	25.0	25.0	0.80	4.80	135.00	19.5	-	-	30.0	999.0	SR 16-212-01397LS	T-2010/5

⁽¹⁾ Minimum cutting width
⁽²⁾ Maximum cutting width



PCHR/L-34

Grooving, Parting and Recessing Holders Carrying Inserts with 5 Cutting Edges

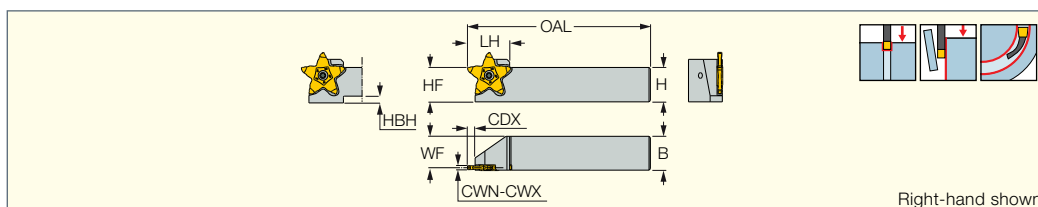

Designation	H	HF	B	CWN ⁽²⁾	CWX ⁽³⁾	WF	CDX ⁽⁴⁾	OAL	LH	HBH		
PCHR/L 16-34	16.0	16.0	16.0	1.50	4.00	14.20	10.00	120.00	31.0	9.0	SR 16-212-01397	T-2010/5
PCHR/L 20-34	20.0	20.0	20.0	1.50	4.00	18.20	10.00	120.00	31.0	6.0	SR 16-212-01397	T-2010/5
PCHR/L 25-34	25.0	25.0	25.0	1.50	4.00	23.20	10.00	135.00	31.0	-	SR 16-212-01397	T-2010/5
PCHR/L 25-34-8 ⁽¹⁾	25.0	25.0	25.0	3.19	8.20	22.50	10.00	135.00	31.0	-	SR PCHR-8-06642	T-15/5
PCHR/L 32-34	32.0	32.0	32.0	1.50	4.00	30.10	10.00	135.00	31.0	-	SR 16-212-01397	T-2010/5

⁽¹⁾ Used with special inserts only
⁽²⁾ Minimum cutting width
⁽³⁾ Maximum cutting width
⁽⁴⁾ For specific information, refer to insert data

PCHR/L-34-JHP

Grooving, Parting and Recessing Tools Carrying PENTA Inserts with Channels for High Pressure Coolant

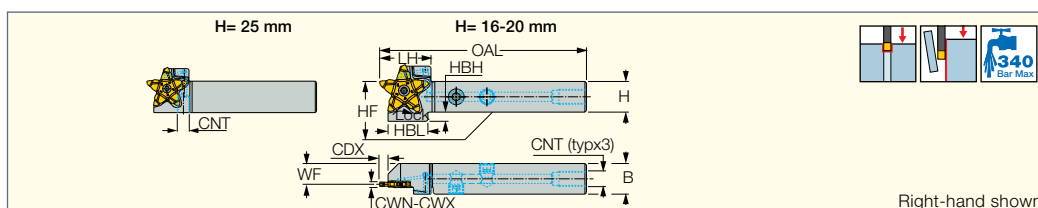

Designation	H	HF	B	CWN ⁽¹⁾	CWX ⁽²⁾	CDX ⁽³⁾	WF	OAL	LH	HBH	CNT	Insert
PCHR/L 16-34-JHP	16.0	16.0	16.0	1.50	4.00	10.00	9.60	120.00	33.5	9.0	UNF 5/16-24	PENTA 34
PCHR/L 20-34-JHP	20.0	20.0	20.0	1.50	4.00	10.00	13.60	135.00	33.5	6.0	G1/8-28	PENTA 34
PCHR/L 25-34-JHP	25.0	25.0	25.0	1.50	4.00	10.00	18.60	135.00	33.5	-	G1/8-28	PENTA 34

• For user guide and accessories, see pages 380-400
⁽¹⁾ Minimum cutting width
⁽²⁾ Maximum cutting width
⁽³⁾ For specific information, refer to insert data

Spare Parts

Designation				
PCHR/L 16-34-JHP	SR 16-212-01397	T-2010/5	SR 5/16UNF TL360	HW 5/32"
PCHR/L 20-34-JHP	SR 16-212-01397	T-2010/5	PLUG G1/8-6.5 TL360	HW 5.0
PCHR/L 25-34-JHP	SR 16-212-01397	T-2010/5		

PENTACUT JETCUT
PARTING & GROOVING LINE

PCHR/L-34-JHP-MC
Grooving, Parting and Recessing
Tools Carrying PENTA
Inserts with Bottom Inlets
for High Pressure Coolant

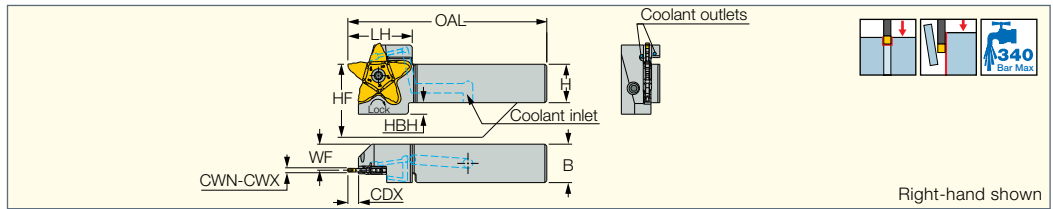



Right-hand shown

Designation	H	HF	B	CWN ⁽¹⁾	CWX ⁽²⁾	CDX ⁽³⁾	WF	OAL	LH	HBH	Insert
PCHR/L 20-34-JHP-MC	20.0	20.0	20.0	1.50	4.00	10.00	13.55	103.50	33.5	6.0	PENTA 34
PCHR/L 25-34-JHP-MC	25.0	25.0	25.0	1.50	4.00	10.00	18.55	118.50	33.5	-	PENTA 34

• For user guide and accessories, see pages 380-400

- (1) Minimum cutting width
- (2) Maximum cutting width
- (3) For specific information, refer to insert data

Spare Parts



Designation		
PCHR/L-34-JHP-MC	SR 16-212-01397	T-2010/5

PENTACUT
PARTING & GROOVING LINE

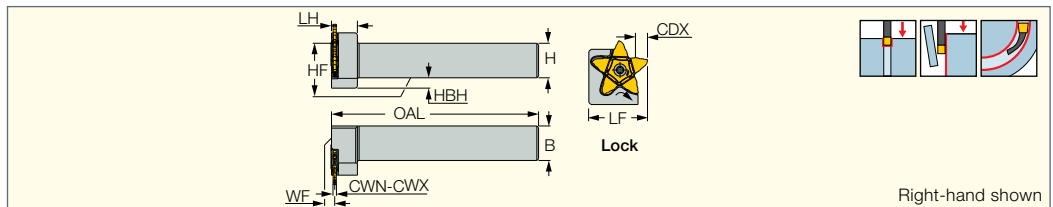
PCHPR/L
Perpendicular Holders
Carrying Inserts with 5 Cutting
Edges for Facing, Grooving,
Parting and Recessing



Right-hand shown

Designation	H	B	CWN ⁽¹⁾	CWX ⁽²⁾	CDX ⁽³⁾	HF	WF	LF	OAL	LH	HBH		
PCHPR/L 16-24	16.0	16.0	0.50	3.20 ⁽⁴⁾	6.50	16.0	1.50 ⁽⁵⁾	23.5	120.00	11.5	-	SR 16-212-01397	T-20/5
PCHPR/L 20-24	20.0	20.0	0.50	3.20 ⁽⁴⁾	6.50	20.0	1.50 ⁽⁵⁾	28.0	120.00	11.5	-	SR 16-212-01397	T-20/5
PCHPR/L 25-24	25.0	25.0	0.50	3.20 ⁽⁴⁾	6.50	25.0	1.50 ⁽⁵⁾	33.0	135.00	11.5	-	SR 16-212-01397	T-20/5
PCHPR/L 20-34	20.0	20.0	1.40	4.00	10.00	20.0	1.90	34.0	120.00	15.0	6.0	SR 16-212-01397	T-20/5
PCHPR/L 25-34	25.0	25.0	1.40	4.00	10.00	25.0	1.90	34.0	135.00	15.0	-	SR 16-212-01397	T-20/5



- (1) Minimum cutting width
- (2) Maximum cutting width
- (3) For specific information, refer to insert data.
- (4) Up to 6.2 mm width may be ordered on request.
- (5) Valid for inserts with CW<3.2 mm

PENTACUT
PARTING & GROOVING LINE
MODULAR GRIP

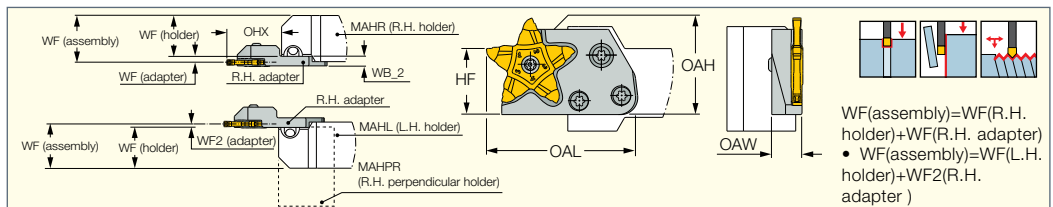
PCADR/L
Adapters for PENTACUT
Grooving Inserts



WF(assembly)=WF(R.H. holder)+WF(R.H. adapter)
• WF(assembly)=WF(L.H. holder)+WF2(R.H. adapter)

Designation	CWN ⁽¹⁾	CWX ⁽²⁾	OHX ⁽³⁾	OAL	WF ⁽⁴⁾	WF ₂	OAW	WB_2	HF	H		
PCADR/L 24N	0.50	3.18 ⁽⁵⁾	17.00	41.50	3.20	2.00	9.00	5.2	24.0	30.3	SR 16-212-01397L ^(a)	T-2010/5
PCADR/L 34N	1.50	4.00	29.60	54.20	3.35	1.85	11.00	5.2	24.0	31.0	SR 16-212-01397	T-2010/5

- CDX and CUTDIA according to insert limitation
- (1) Minimum cutting width
- (2) Maximum cutting width
- (3) Maximum overhang
- (4) WF (adapter)
- (5) Up to 6.2 mm width may be ordered on request

(a) For left-hand holders

PCADR/L-JHP

Adapters with High Pressure Coolant Holes for PENTACUT Grooving Inserts

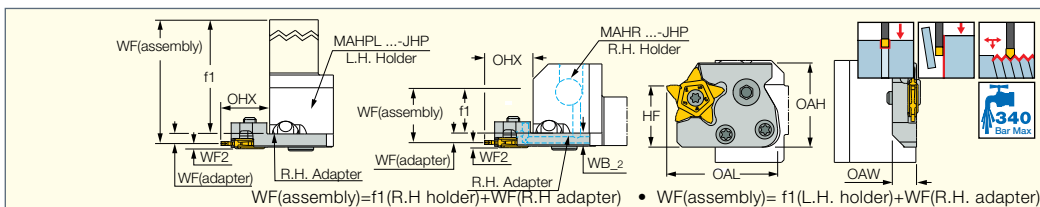

Designation	CWN ⁽¹⁾	CWX ⁽²⁾	OHX ⁽³⁾	OAL	WF ⁽⁴⁾	WF ₂	OAW	WB_2	HF	OAH	Insert		
PCADR/L 24-JHP	0.50	3.18 ⁽⁵⁾	19.30	43.80	5.20	2.00	10.00	7.2	24.0	33.0	PENTA 24	SR 16-212-01397L	T-2010/5

• CDX and CUTDIA according to insert limitation • For user guide and accessories, see pages 380-400

- ⁽¹⁾ Minimum cutting width
- ⁽²⁾ Maximum cutting width
- ⁽³⁾ Maximum overhang
- ⁽⁴⁾ WF(adapter)
- ⁽⁵⁾ Up to 6.2 mm width can be ordered on request

Flow Rate vs. Pressure

Designation	70 Bar Flow Rate (liters/min)	100 Bar Flow Rate (liters/min)	140 Bar Flow Rate (liters/min)
PCADR/L 24-JHP	9-11	11-13	12-14

PCAD RE/LE-JHP

Parting and Grooving Adapters with Channels for High Pressure Coolant Carrying PENTA 24 Inserts

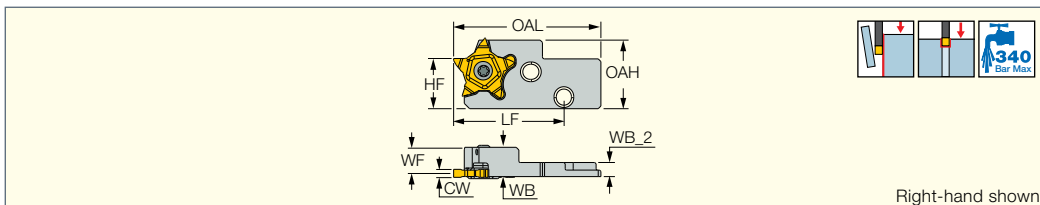

Designation	CWN ⁽¹⁾	CWX ⁽²⁾	WF	WB	WB_2	LF	OAL	OAH	HF	Insert
PCAD 24R/LE-JHP	0.50	3.18	5.20	11.00	5.3	41.40	55.30	25.8	18.9	PENTA 24

• For user guide and accessories, see pages 380-400

- ⁽¹⁾ Minimum cutting width
- ⁽²⁾ Maximum cutting width

For inserts, see pages: PENTA 24-BSPT (309) • PENTA 24-ISO (308) • PENTA 24-MT (309) • PENTA 24-NPT (630) • PENTA 24-UN (308) • PENTA 24-W (308) • PENTA 24-WT (309) • PENTA 24N-C (304) • PENTA 24N-C (full radius) (305) • PENTA 24N-J (303) • PENTA 24N-J (full radius) (304) • PENTA 24N-PF (full radius) (306) • PENTA 24N-PF/P (305) • PENTA 24N-Z (306) • PENTA 24R-C (480) • PENTA 24R-P (482) • PENTA 24R/L-J (480) • PENTA 24R/L-Z (481)

For holders, see pages: NMAHR/L-JHP (458)

Spare Parts

Designation		
PCAD 24LE-JHP	SR 16-212-01397L ^(a)	T-2010/5
PCAD 24RE-JHP	SR 16-212-01397 ^(a)	T-2010/5

^(a) Recommended tightening torque: 2.5 N*m (22 lbf*in)

PENTACUT
PARTING & GROOVING LINE
PCADR/L 34N-RE
Reinforced Adapters for PENTACUT Grooving Inserts

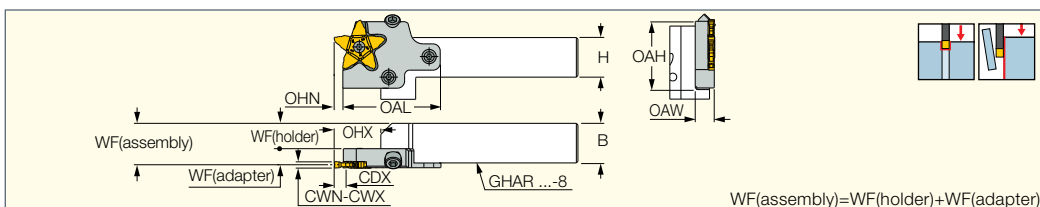

Designation	CWN ⁽¹⁾	CWX ⁽²⁾	OHN ⁽³⁾	OHX ⁽⁴⁾	OAL	WF ⁽⁵⁾	OAH	OAW		
PCADR/L 34N-RE	1.50	4.00	5.50	29.50	61.50	10.15	42.0	12.00	SR 16-212-01397	T-2010/5



• CDX and CUTDIA according to insert limitation • H, B, and WF(holder) according to holder being used

- ⁽¹⁾ Minimum cutting width
- ⁽²⁾ Maximum cutting width
- ⁽³⁾ Minimum overhang
- ⁽⁴⁾ Maximum overhang
- ⁽⁵⁾ WF(adapter)

PCHBR/L

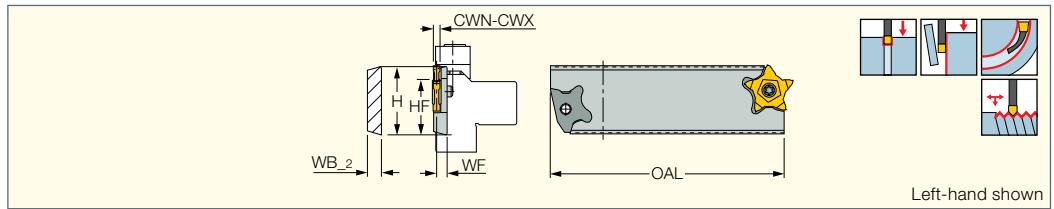
Double-Ended Parting and Grooving Blades for PENTACUT Inserts



Designation	H	CWN ⁽²⁾	CWX ⁽³⁾	HF	WF ⁽⁴⁾	OAL	WB_2	Insert		
PCHBR/L 26-24R	26.0	0.50	6.20	21.4	7.00	110.00	8.5	PENTA 24	SR 16-212-01397L	T-2010/5
PCHBL 32-24R	32.0	0.50	6.20	24.8	7.00	110.00	8.5	PENTA 24	SR 16-212-01397L	T-2010/5
PCHBR 26-24L	26.0	0.50	6.20	21.4	7.00	110.00	8.5	PENTA 24	SR 16-212-01397	T-2010/5
PCHBR 32-24L	32.0	0.50	6.20	24.8	7.00	110.00	8.5	PENTA 24	SR 16-212-01397	T-2010/5
PCHBR/L 26-34R⁽¹⁾	26.0	1.50	4.00	21.4	7.15	110.00	8.5	PENTA 34	SR 16-212-01397	T-2010/5
PCHBL 32-34R	32.0	1.50	4.00	24.8	7.15	110.00	8.5	PENTA 34	SR 16-212-01397	T-2010/5
PCHBR 26-34L⁽¹⁾	26.0	1.50	4.00	21.4	7.15	110.00	8.5	PENTA 34	SR 16-212-01397	T-2010/5
PCHBR 32-34L	32.0	1.50	4.00	24.8	7.15	110.00	8.5	PENTA 34	SR 16-212-01397	T-2010/5

• For insert/blade orientation, see the following drawings

⁽¹⁾ Single pocket blade

⁽²⁾ Minimum cutting width

⁽³⁾ Maximum cutting width

⁽⁴⁾ To the center of inserts up to 4.15 mm width

For inserts, see pages: PENTA 24-BSPT (309) • PENTA 24-ISO (308) • PENTA 24-MT (309) • PENTA 24-NPT (630) • PENTA 24-UN (308) • PENTA 24-W (308) • PENTA 24-WT (309) • PENTA 24N-C (304) • PENTA 24N-C (full radius) (305) • PENTA 24N-J (303) • PENTA 24N-J (full radius) (304) • PENTA 24N-PF (full radius) (306) • PENTA 24N-PF/P (305) • PENTA 24N-Z (306) • PENTA 24R-C (480) • PENTA 24R-P (482) • PENTA 24R/L-J (480) • PENTA 24R/L-Z (481) • PENTA 34F-R/L (670) • PENTA 34N-C (310) • PENTA 34N-J (311) • PENTA 34N-PB (310) • PENTA 34R/L-C (482) • PENTA 34R/L-J (483) • PENTA 34R/L-PB (483)

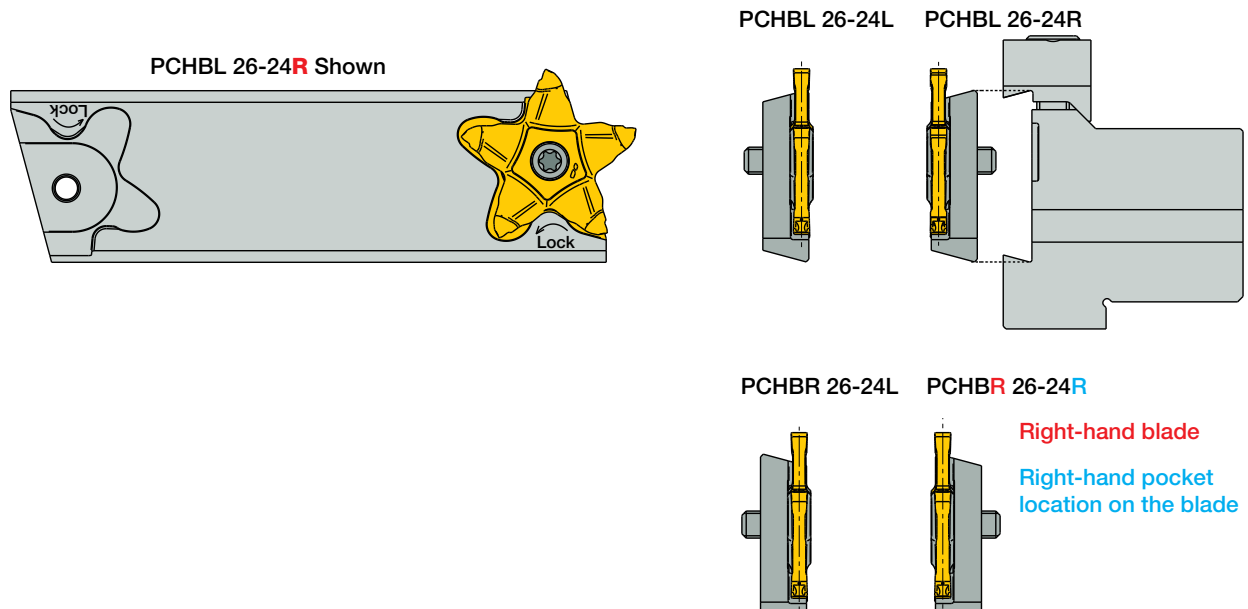

Identification System for Standard Inserts

PENTA

Family name

24

Circular circumference of the insert

N

Insert lead angle (K)
N, R, L

150

Cutting edge width CW(mm)x100

J

Chipbreaker style **J, Z**

010

Corner radius RE (mm)x100 for neutral insert. (k=0)
Or lead angle for right- or left-hand inserts. (eg. 15D=15°)



PENTA 24N-J

Inserts with 5 Cutting Edges for Parting and Grooving Soft Materials, Tubes, Small and Thin-Walled Parts

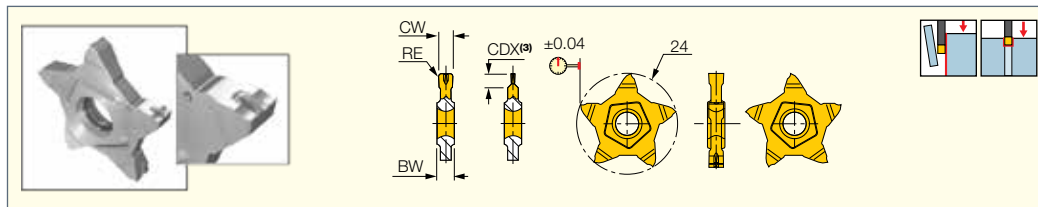

Designation	Dimensions						Tough ↔ Hard			Recommended Machining Data f groove (mm/rev)
	CW	RE	CWTOL ⁽¹⁾	RETOL ⁽²⁾	BW	CDX ⁽³⁾	IC1008	IC908	IC807G	
PENTA 24N050J000	0.50	0.00	0.02	0.020	4.00	1.00		•		0.02-0.04
PENTA 24N050J004	0.50	0.04	0.02	0.020	4.00	2.50	•			0.02-0.05
PENTA 24N080J000	0.80	0.00	0.02	0.020	4.00	1.60		•		0.02-0.05
PENTA 24N100J004	1.00	0.04	0.02	0.020	4.00	3.50		•		0.03-0.07
PENTA 24N100J006	1.00	0.06	0.02	0.020	4.00	3.50	•		•	0.03-0.07
PENTA 24N104J000	1.04	0.00	0.02	0.020	4.00	2.00		•		0.02-0.07
PENTA 24N120J000	1.20	0.00	0.02	0.020	4.00	2.00		•	•	0.03-0.07
PENTA 24N125J010	1.25	0.10	0.02	0.020	4.00	2.00		•		0.03-0.07
PENTA 24N140J000	1.40	0.00	0.02	0.020	4.00	2.00		•		0.03-0.08
PENTA 24N147J000	1.47	0.00	0.02	0.020	4.00	2.50		•		0.03-0.08
PENTA 24N150J010	1.50	0.10	0.00	0.020	4.00	5.00	•	•	•	0.03-0.10
PENTA 24N157J015	1.57	0.15	0.02	0.030	4.00	3.00		•	•	0.00-0.12
PENTA 24N170J010	1.70	0.10	0.02	0.030	4.00	3.00		•	•	0.03-0.12
PENTA 24N178J018	1.78	0.18	0.02	0.030	4.00	3.00		•	•	0.04-0.12
PENTA 24N185J015	1.85	0.15	0.02	0.030	4.00	3.00		•		0.04-0.12
PENTA 24N196J015	1.96	0.15	0.02	0.030	4.00	3.00		•	•	0.04-0.12
PENTA 24N200J020	2.00	0.20	0.02	0.030	4.00	6.00	•	•	•	0.04-0.12
PENTA 24N222J015	2.22	0.15	0.02	0.030	4.00	3.50		•	•	0.04-0.16
PENTA 24N230J020	2.30	0.20	0.02	0.030	4.00	3.50		•	•	0.04-0.16
PENTA 24N239J015	2.39	0.15	0.02	0.030	4.00	5.00		•	•	0.04-0.16
PENTA 24N247J020	2.47	0.20	0.02	0.030	4.00	5.00		•	•	0.04-0.16
PENTA 24N270J010	2.70	0.10	0.02	0.020	4.00	5.00		•		0.04-0.16
PENTA 24N287J020	2.87	0.20	0.02	0.030	4.00	6.50		•		0.04-0.16
PENTA 24N300J000	3.00	0.00	0.02	0.020	4.00	6.50		•		0.04-0.10
PENTA 24N300J020	3.00	0.20	0.02	0.030	4.00	6.50		•	•	0.04-0.16
PENTA 24N300J040	3.00	0.40	0.02	0.030	4.00	6.50		•	•	0.04-0.16
PENTA 24N315J015	3.15	0.15	0.02	0.030	4.00	6.50		•		0.04-0.16
PENTA 24N318J020	3.18	0.20	0.02	0.030	4.00	6.50		•	•	0.04-0.16
PENTA 24N330J010	3.30	0.10	0.02	0.030	5.00	6.40		•		0.04-0.16
PENTA 24N348J020	3.48	0.20	0.02	0.030	5.00	6.40		•		0.04-0.18
PENTA 24N356J020	3.56	0.20	0.02	0.030	5.00	6.40		•		0.04-0.18
PENTA 24N374J020	3.74	0.20	0.02	0.030	5.00	6.40		•		0.04-0.18
PENTA 24N398J020	3.98	0.20	0.02	0.030	5.00	6.20		•		0.04-0.18
PENTA 24N400J040	4.00	0.40	0.02	0.030	5.00	6.20		•		0.04-0.18
PENTA 24N423J010	4.23	0.10	0.02	0.030	5.00	6.20		•		0.04-0.18

• (1)Recessing is possible only with 2.39 mm and wider inserts • For cutting speed recommendations and user guide, see pages 380-395

(1) Cutting width tolerance (+/-)

(2) Corner radius tolerance (+/-)

(3) For grooving and parting depth relative to part diameter, see page 306

For tools, see pages: PCAD RE/LE-JHP (301) • PCADR/L (300) • PCADR/L-JHP (301) • PCHBR/L (302) • PCHPR/L (300) • PCHR/L-24 (297) • PCHR/L-24-JHP (298) • PCHR/L-24-JHP-MC (298)



PENTA 24N-J (full radius)

Precision Grooving
 Pentagonal Full Radius
 Inserts for Soft Materials

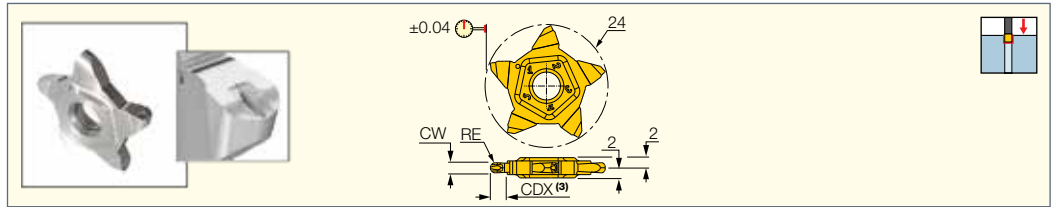

Designation	Dimensions					Tough ↔ Hard		Recommended Machining Data
	CW	RE	CWTOL ⁽¹⁾	RETOL ⁽²⁾	CDX ⁽³⁾	IC908	IC807G	
PENTA 24N100J050	1.00	0.50	0.02	0.050	3.50	●		f groove (mm/rev) 0.03-0.07
PENTA 24N120J060	1.20	0.60	0.02	0.050	2.00	●		0.03-0.07
PENTA 24N140J070	1.40	0.70	0.02	0.050	2.00	●		0.05-0.08
PENTA 24N157J079	1.57	0.79	0.02	0.050	3.00	●	●	0.05-0.08
PENTA 24N200J100	2.00	1.00	0.02	0.050	3.00	●	●	0.05-0.12
PENTA 24N239J120	2.39	1.20	0.02	0.050	5.00	●		0.06-0.16
PENTA 24N300J150	3.00	1.50	0.02	0.050	6.50	●	●	0.06-0.20
PENTA 24N318J159	3.18	1.59	0.02	0.050	6.50	●		0.06-0.20
PENTA 24N400J200	4.00	2.00	0.02	0.050	6.25	●		0.06-0.20

• Recessing is possible only with 2.39 mm and wider inserts. • For cutting speed recommendations and user guide, see pages 380-395

⁽¹⁾ Cutting width tolerance (+/-)

⁽²⁾ Corner radius tolerance (+/-)

⁽³⁾ For grooving depth relative to part diameter, see page 306

For tools, see pages: PCAD RE/LE-JHP (301) • PCADR/L (300) • PCADR/L-JHP (301) • PCHBR/L (302) • PCHPR/L (300) • PCHR/L-24 (297) • PCHR/L-24-JHP (298) • PCHR/L-24-JHP-MC (298)



PENTA 24N-C

Parting and Grooving Inserts
 with 5 Cutting Edges for
 Parting Bars, Hard Materials
 and Tough Applications

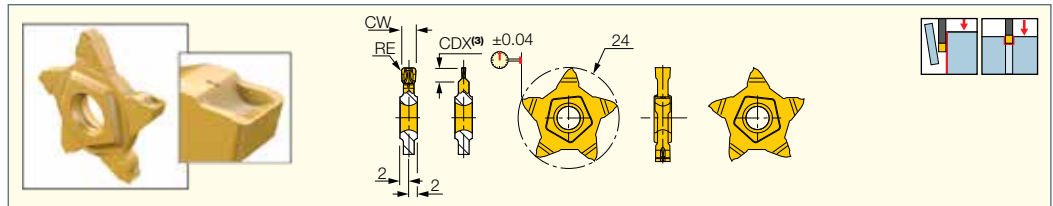

Designation	Dimensions					IC908	Recommended Machining Data
	CW	RE	CWTOL ⁽¹⁾	RETOL ⁽²⁾	CDX ⁽³⁾		
PENTA 24N150C010	1.50	0.10	0.02	0.050	5.00	●	f groove (mm/rev) 0.05-0.11
PENTA 24N157C015	1.57	0.15	0.02	0.050	3.00	●	0.05-0.12
PENTA 24N170C010	1.70	0.10	0.02	0.050	3.00	●	0.05-0.13
PENTA 24N178C018	1.78	0.18	0.02	0.050	3.00	●	0.05-0.14
PENTA 24N196C015	1.96	0.15	0.02	0.050	3.00	●	0.05-0.15
PENTA 24N200C020	2.00	0.20	0.02	0.050	6.00	●	0.05-0.16
PENTA 24N222C015	2.22	0.15	0.02	0.050	3.50	●	0.05-0.16
PENTA 24N230C020	2.30	0.20	0.02	0.050	3.50	●	0.06-0.17
PENTA 24N239C015	2.39	0.15	0.02	0.050	5.00	●	0.07-0.18
PENTA 24N247C020	2.47	0.20	0.02	0.050	5.00	●	0.08-0.18
PENTA 24N270C010	2.70	0.10	0.02	0.050	6.20	●	0.09-0.18
PENTA 24N287C020	2.87	0.20	0.02	0.050	6.20	●	0.10-0.18
PENTA 24N300C020	3.00	0.20	0.02	0.050	6.20	●	0.10-0.20
PENTA 24N300C040	3.00	0.40	0.02	0.050	6.20	●	0.10-0.20
PENTA 24N318C020	3.18	0.20	0.02	0.050	6.20	●	0.10-0.20
PENTA 24N478C055	4.78	0.55	0.02	0.050	6.20	●	0.10-0.25
PENTA 24N486C040	4.86	0.40	0.02	0.050	6.20	●	0.10-0.25
PENTA 24N500C040	5.00	0.40	0.02	0.050	6.20	●	0.10-0.25

• (1)Recessing is possible only with 2.39 mm and wider inserts • For cutting speed recommendations and user guide, see pages 380-395

⁽¹⁾ Cutting width tolerance (+/-)

⁽²⁾ Corner radius tolerance (+/-)

⁽³⁾ For grooving and parting depths relative to part diameter, see page 306

For tools, see pages: PCAD RE/LE-JHP (301) • PCADR/L (300) • PCADR/L-JHP (301) • PCHBR/L (302) • PCHPR/L (300) • PCHR/L-24 (297) • PCHR/L-24-JHP (298) • PCHR/L-24-JHP-MC (298)

PENTA 24N-C (full radius)

Full Radius Grooving Inserts with 5 Cutting Edges for Hard Materials and Tough Applications

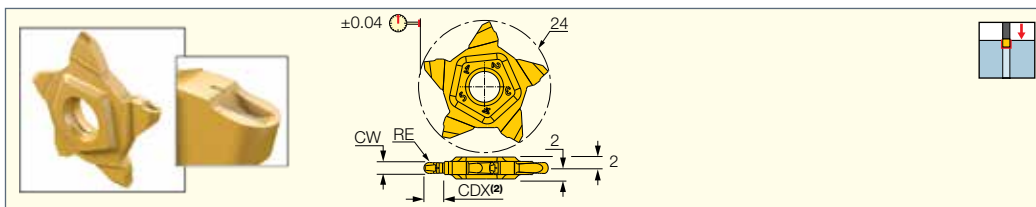

Designation	Dimensions				IC908	Recommended Machining Data
	CW	RE	CWTOL ⁽¹⁾	CDX ⁽²⁾		f groove (mm/rev)
PENTA 24N157C079	1.57	0.79	0.02	3.00	●	0.04-0.12
PENTA 24N200C100	2.00	1.00	0.02	3.00	●	0.04-0.16
PENTA 24N239C120	2.39	1.20	0.02	5.00	●	0.06-0.18
PENTA 24N300C150	3.00	1.50	0.02	6.20	●	0.10-0.25

• Recessing is possible only with 2.39 mm and wider inserts • For cutting speed recommendations and user guide, see pages 380-395

⁽¹⁾ Cutting width tolerance (+/-)

⁽²⁾ For grooving depth relative to part diameter, see page 306

For tools, see pages: PCAD RE/LE-JHP (301) • PCADR/L (300) • PCADR/L-JHP (301) • PCHBR/L (302) • PCHPR/L (300) • PCHR/L-24 (297) • PCHR/L-24-JHP (298) • PCHR/L-24-JHP-MC (298)

PENTA 24N-PF/P

Pentagonal Inserts with a High Positive Flat Rake for Parting and Precision Grooving

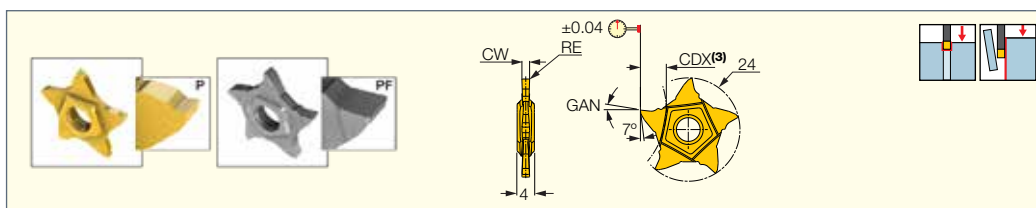

Designation	Dimensions						Tough ↔ Hard			Recommended Machining Data
	CW	RE	CWTOL ⁽¹⁾	RETOL ⁽²⁾	CDX ⁽³⁾	GAN	IC1008	IC908	IC30N	
PENTA 24N050PF005	0.50	0.05	0.02	0.020	2.50	6.0			●	0.01-0.04
PENTA 24N075PF005	0.75	0.05	0.02	0.020	2.50	6.0			●	0.02-0.05
PENTA 24N095PF005	0.95	0.05	0.02	0.020	4.00	6.0			●	0.02-0.05
PENTA 24N100PF010	1.00	0.10	0.02	0.020	4.00	6.0		●	●	0.03-0.06
PENTA 24N100P005	1.00	0.05	0.02	0.020	3.50	12.0	●			0.02-0.05
PENTA 24N125PF020	1.25	0.20	0.02	0.020	5.00	6.0			●	0.03-0.06
PENTA 24N145PF020	1.45	0.20	0.02	0.020	6.20	6.0			●	0.03-0.06
PENTA 24N150PF020	1.50	0.20	0.02	0.030	6.00	6.0		●	●	0.03-0.09
PENTA 24N150P005	1.50	0.05	0.02	0.020	5.00	12.0	●			0.02-0.07
PENTA 24N175PF020	1.75	0.20	0.02	0.030	6.20	6.0			●	0.02-0.08
PENTA 24N185PF020	1.85	0.20	0.02	0.030	6.00	6.0			●	0.03-0.10
PENTA 24N200PF020	2.00	0.20	0.02	0.030	6.50	6.0		●	●	0.04-0.10
PENTA 24N200P005	2.00	0.05	0.02	0.020	6.00	12.0	●			0.02-0.08
PENTA 24N230PF020	2.30	0.20	0.02	0.030	6.20	6.0			●	0.04-0.14
PENTA 24N239PF015	2.39	0.15	0.02	0.030	6.50	6.0		●		0.04-0.14
PENTA 24N250PF020	2.50	0.20	0.02	0.030	6.50	6.0		●	●	0.04-0.14
PENTA 24N300PF020	3.00	0.20	0.02	0.030	6.50	6.0		●	●	0.04-0.14
PENTA 24N300PF030	3.00	0.30	0.02	0.030	6.20	6.0			●	0.04-0.15
PENTA 24N400PF020	4.00	0.20	0.02	0.030	6.50	6.0			●	0.04-0.16
PENTA 24N400PF040	4.00	0.40	0.02	0.030	6.20	6.0			●	0.04-0.16

• For cutting speed recommendations and user guide, see pages 380-395

⁽¹⁾ Cutting width tolerance (+/-)

⁽²⁾ Corner radius tolerance (+/-)

⁽³⁾ For grooving and parting depths relative to part diameter, see page 306

For tools, see pages: PCAD RE/LE-JHP (301) • PCADR/L (300) • PCADR/L-JHP (301) • PCHBR/L (302) • PCHPR/L (300) • PCHR/L-24 (297) • PCHR/L-24-JHP (298) • PCHR/L-24-JHP-MC (298)



PENTA 24N-PF (full radius)

Full Radius Pentagonal Inserts with a High Positive Flat Rake for Parting and Precision Grooving

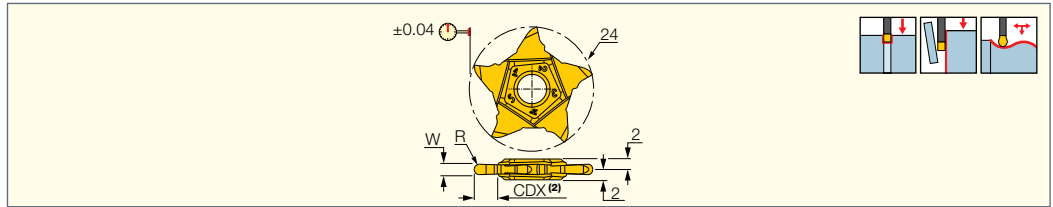

Designation	Dimensions					IC30N	Recommended Machining Data
	CW	RE	CWTOL ⁽¹⁾	CDX ⁽²⁾	GAN		f groove (mm/rev)
PENTA 24N100PF050	1.00	0.50	0.02	4.50	6.0	●	0.03-0.06
PENTA 24N150PF075	1.50	0.75	0.02	6.20	6.0	●	0.03-0.06
PENTA 24N200PF100	2.00	1.00	0.02	6.20	6.0	●	0.04-0.10
PENTA 24N250PF125	2.50	1.25	0.02	6.20	6.0	●	0.04-0.14
PENTA 24N300PF150	3.00	1.50	0.02	6.20	6.0	●	0.04-0.15
PENTA 24N400PF200	4.00	2.00	0.02	6.20	6.0	●	0.04-0.16

• For cutting speed recommendations and user guide, see pages 380-395

⁽¹⁾ Cutting width tolerance (+/-)

⁽²⁾ For grooving and parting depths relative to part diameter, see page 306

For tools, see pages: PCADR/LE-JHP (301) • PCADR/L (300) • PCADR/L-JHP (301) • PCHBR/L (302) • PCHPR/L (300) • PCHR/L-24 (297) • PCHR/L-24-JHP (298) • PCHR/L-24-JHP-MC (298)



PENTA 24N-Z

Inserts with 5 Cutting Edges for Grooving and Parting Tubes, Small and Thin-Walled Parts

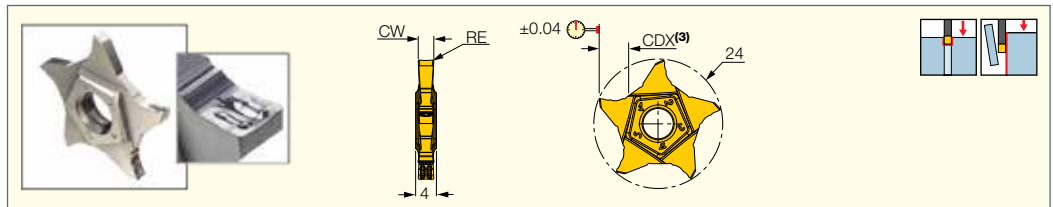

Designation	Dimensions					IC908	Recommended Machining Data
	CW	RE	CWTOL ⁽¹⁾	RETOL ⁽²⁾	CDX ⁽³⁾		f groove (mm/rev)
PENTA 24N150Z010	1.50	0.10	0.02	0.020	5.00	●	0.05-0.08
PENTA 24N200Z020	2.00	0.20	0.02	0.030	6.40	●	0.04-0.12
PENTA 24N300Z020	3.00	0.20	0.02	0.000	6.40	●	0.04-0.16

• Cutting edge with high positive rake, suitable for parting tubes, thin walled parts and for small diameters • Suitable for machining soft materials and bearing steel at low to medium feeds • For cutting speed recommendations and user guide, see pages 380-395

⁽¹⁾ Cutting width tolerance (+/-)

⁽²⁾ Corner radius tolerance (+/-)

⁽³⁾ For grooving and parting depths relative to part diameter, see page 306

For tools, see pages: PCADR/LE-JHP (301) • PCADR/L (300) • PCADR/L-JHP (301) • PCHBR/L (302) • PCHPR/L (300) • PCHR/L-24 (297) • PCHR/L-24-JHP (298) • PCHR/L-24-JHP-MC (298)

CUTDIA as a Function of Parting / Grooving Depth (T) for PENTA 24 Inserts

CW±0.02	CDX ⁽³⁾	CDX / CUTDIA	T≤3.0	T≤3.5	T≤4.0	T≤4.5	T≤5.0	T≤5.5	T≤6.5	T≤6.4
CW=0.50 ⁽¹⁾	1.0	1.0 / N.L.	-	-	-	-	-	-	-	-
CW=0.50 ⁽²⁾	2.5			250						
CW=0.80	1.6	1.6 / N.L.								
CW=1.00	3.5		N.L.	250						
1.04≤CW≤1.40	2.0	2.0 / N.L.								
CW=1.47	2.5	2.5 / N.L.								
CW=1.50	5.0		N.L.	470	210	70	30			
1.57≤CW≤1.96	3.0		N.L.							
CW=2.00	6.0 ⁽⁴⁾		N.L.	470	210	130	75	45	20	
2.22≤CW≤2.30	3.5		N.L.	250						
2.39≤CW≤2.50	5.0		N.L.	470	210	70	30			
2.70≤CW≤3.18	6.4		N.L.	470	210	135	100	70	40	20

⁽¹⁾ Refers to PENTA 24N050J000 - a precision grooving insert ⁽²⁾ Refers to PENTA 24N050J004 - a parting insert ⁽³⁾ CUTDIA for parting = 2 x CDX

⁽⁴⁾ For full radius insert, CDX = 3.0, CUTDIA = No limit

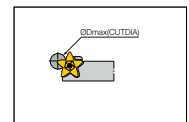
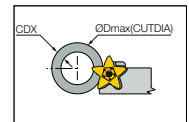

PENTA 24N-J-RS
Parting and Precision Grooving
Pentagonal Inserts for Next to
High Shoulder Applications

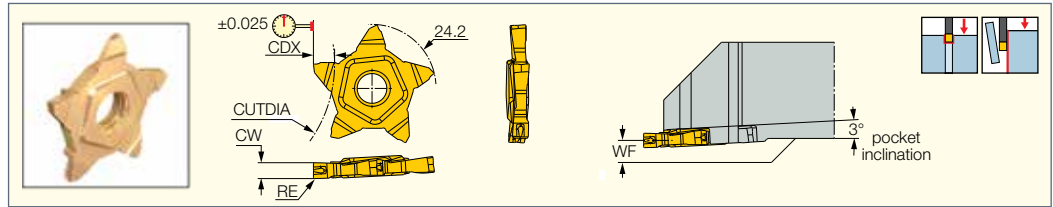

Designation	Dimensions						IC908	Recommended Machining Data
	CW	RE	CWTOL ⁽¹⁾	CDX	CUTDIA	WF		
PENTA 24N157J020RS	1.57	0.20	0.20	3.00	-	1.20	●	0.03-0.10
PENTA 24N157J079RS	1.57	0.79	0.20	3.00	-	1.20	●	0.04-0.12
PENTA 24N200J020RS	2.00	0.20	0.20	3.00	-	1.00	●	0.04-0.12
PENTA 24N239J020RS	2.39	0.20	0.20	5.00	3.0	0.80	●	0.04-0.14
PENTA 24N239J119RS	2.39	1.19	0.20	5.00	3.0	0.80	●	0.04-0.16
PENTA 24N300J020RS	3.00	0.20	0.20	6.20	16.0	0.40	●	0.04-0.16
PENTA 24N318J020RS	3.18	0.20	0.20	6.20	16.0	0.40	●	0.04-0.16
PENTA 24N318J159RS	3.18	1.59	0.20	6.20	16.0	0.40	●	0.04-0.16

⁽¹⁾ Cutting width tolerance (+/-)
For tools, see pages: PCHRS/LS (299)

PENTA 24N-RS/LS
Pentagonal Inserts for Parting
and Precision Grooving Next to
High Shoulder Applications

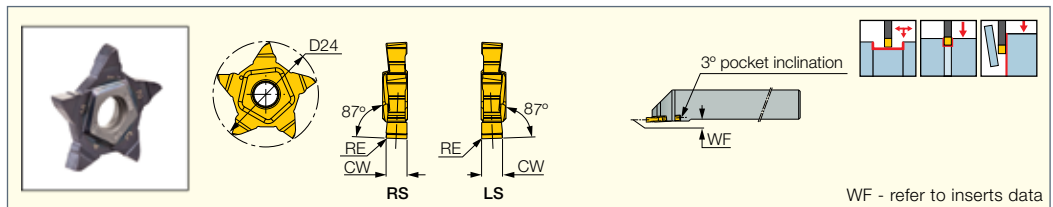

WF - refer to inserts data

Designation	Dimensions						IC908	Recommended Machining Data
	CW	RE	CWTOL ⁽¹⁾	CDX ⁽²⁾	CUTDIA	WF		
PENTA 24N080NF010R/LS	0.80	0.10	0.02	1.60	- ⁽³⁾	1.60	●	0.03-0.05
PENTA 24N100NF010R/LS	1.00	0.10	0.02	1.80	- ⁽³⁾	1.50	●	0.03-0.06
PENTA 24N119NF010R/LS	1.19	0.10	0.02	2.00	- ⁽³⁾	1.40	●	0.03-0.06
PENTA 24N157NF020R/LS	1.57	0.20	0.02	3.00	- ⁽³⁾	1.20	●	0.03-0.08
PENTA 24N157NF079R/LS	1.57	0.79	0.02	3.00	- ⁽³⁾	1.20	●	0.03-0.08
PENTA 24N200NF020R/LS	2.00	0.20	0.02	3.00	- ⁽³⁾	1.00	●	0.03-0.10
PENTA 24N239NF020R/LS	2.39	0.20	0.02	5.00	40.0	0.80	●	0.03-0.12
PENTA 24N239NF119R/LS	2.39	1.19	0.02	5.00	40.0	0.80	●	0.03-0.12
PENTA 24N300NF020R/LS	3.00	0.20	0.02	6.20	16.0	0.50	●	0.04-0.14
PENTA 24N318NF020R/LS	3.18	0.20	0.02	6.50	13.0	0.40	●	0.04-0.14
PENTA 24N318NF159R/LS	3.18	1.59	0.02	6.50	13.0	0.40	●	0.04-0.14
PENTA 24N400NF020R/LS	4.00	0.20	0.02	6.50	13.0	1.00	●	0.04-0.16
PENTA 24N480NF020R/LS	4.80	0.20	0.02	6.50	13.0	1.60	●	0.04-0.16

• For cutting speed recommendations and user guide, see pages 380-395

⁽¹⁾ Cutting width tolerance (+/-)

⁽²⁾ Cutting depth maximum

⁽³⁾ No limit

For tools, see pages: PCHRS/LS (299)

PENTACUT
THREADING LINE

PENTA 24-ISO

Precision Ground ISO Metric Full Profile Pentagonal External Threading Inserts with a Chipformer

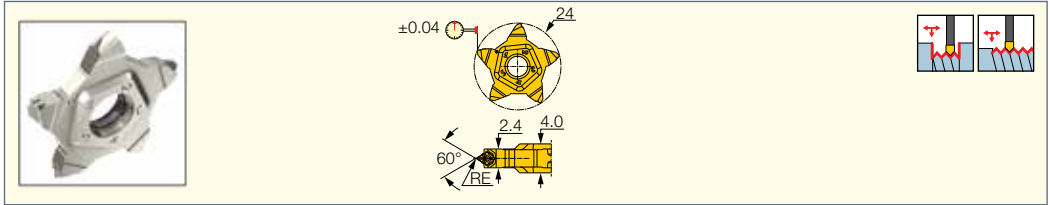

Designation	Dimensions		IC908
	TP	RE	
PENTA 24-0.5-ISO	0.500	0.08	●
PENTA 24-0.75-ISO	0.750	0.11	●
PENTA 24-0.8-ISO	0.800	0.12	●
PENTA 24-1.0-ISO	1.000	0.14	●
PENTA 24-1.25-ISO	1.250	0.18	●
PENTA 24-1.5-ISO	1.500	0.22	●
PENTA 24-1.75-ISO	1.750	0.25	●
PENTA 24-2.0-ISO	2.000	0.28	●

• DMIN(mm)=5.435xTP

For tools, see pages: PCAD RE/LE-JHP (301) • PCADR/L (300) • PCADR/L-JHP (301) • PCHBR/L (302) • PCHPR/L (300) • PCHR/L-24 (297) • PCHR/L-24-JHP (298) • PCHR/L-24-JHP-MC (298)

PENTACUT
THREADING LINE

PENTA 24-UN

American UN (UNC, UNF, UNEF) Precision Ground Full Profile Pentagonal External Inserts with a Chipformer

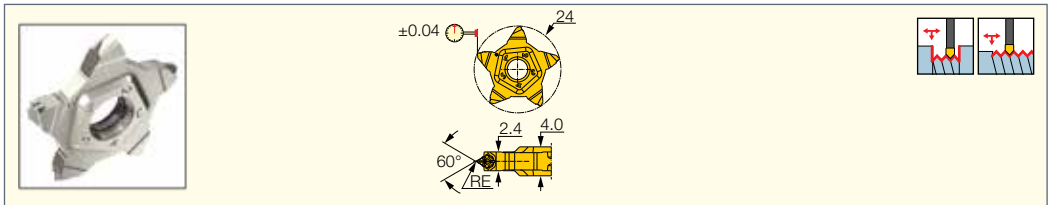

Designation	Dimensions		IC908
	TPI	RE	
PENTA 24-24-UN	24.0	0.13	●
PENTA 24-20-UN	20.0	0.16	●
PENTA 24-18-UN	18.0	0.18	●
PENTA 24-16-UN	16.0	0.21	●
PENTA 24-14-UN	14.0	0.23	●

• DMIN(inch)=5.435/TPI • Tolerance: Class 2A

For tools, see pages: PCAD RE/LE-JHP (301) • PCADR/L (300) • PCADR/L-JHP (301) • PCHBR/L (302) • PCHPR/L (300) • PCHR/L-24 (297) • PCHR/L-24-JHP (298) • PCHR/L-24-JHP-MC (298)

PENTACUT
THREADING LINE

PENTA 24-W

Whitworth (BSW, BSF, BSP) B.S.84-1956 DIN 259 Pentagonal Full Profile External Threading Inserts with a Chipformer

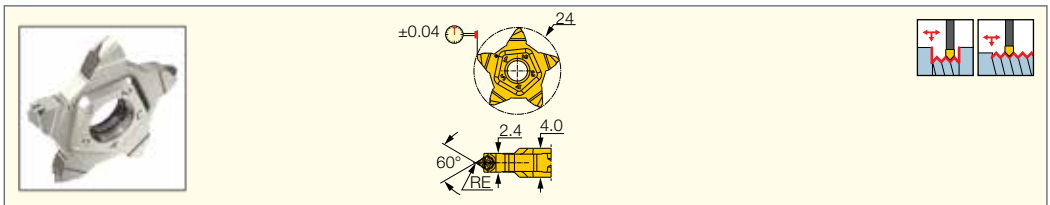

Designation	Dimensions		IC908
	TPI	RE	
PENTA 24-28-W	28.0	0.09	●
PENTA 24-19-W	19.0	0.15	●
PENTA 24-14-W	14.0	0.21	●

• DMIN(inch)=5.435/TPI

For tools, see pages: PCAD RE/LE-JHP (301) • PCADR/L (300) • PCADR/L-JHP (301) • PCHBR/L (302) • PCHPR/L (300) • PCHR/L-24 (297) • PCHR/L-24-JHP (298) • PCHR/L-24-JHP-MC (298)



PENTA 24-BSPT

BSPT (British Standard Pipe)
Precision Ground External
Pentagonal Full Profile Threading
Inserts with a Chipformer

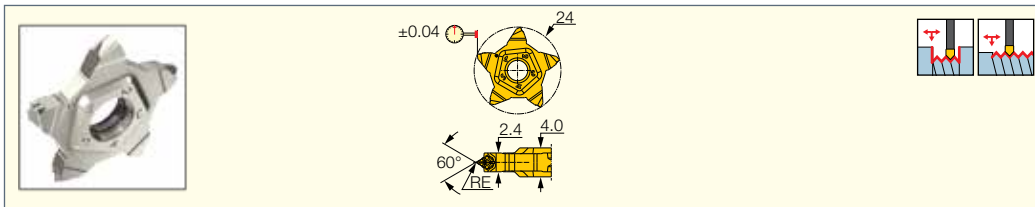

Dimensions				IC908
Designation	TPI	RE		
PENTA 24-19-BSPT	19.0	0.16		●
PENTA 24-14-BSPT	14.0	0.22		●

• DMIN(inch)=5.435/TPI

For tools, see pages: PCAD RE/LE-JHP (301) • PCADR/L (300) • PCADR/L-JHP (301) • PCHBR/L (302) • PCHPR/L (300) • PCHR/L-24 (297) • PCHR/L-24-JHP (298) • PCHR/L-24-JHP-MC (298)



PENTA 24-MT

Precision Ground Pentagonal
External Threading Inserts
with a 60° Partial Profile

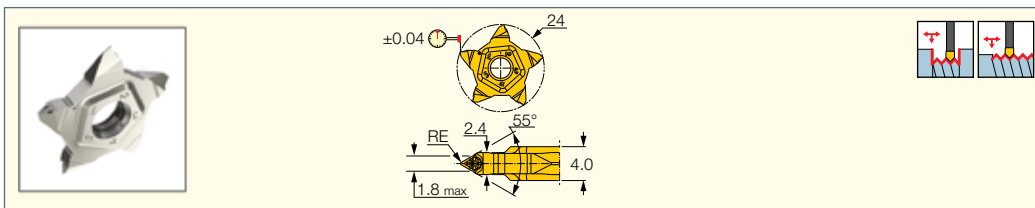

Dimensions				IC908
Designation	TPN ⁽²⁾	TPX ⁽³⁾	RE	
PENTA 24-MT-0.05	0.500	1.750	0.05	●
PENTA 24A-MT-0.05 ⁽¹⁾	0.500	1.750	0.05	●
PENTA 24A-MT-0.15	1.250	1.750	0.15	●

• TPX=0.175xD

⁽¹⁾ Flat rake (without a chipformer)

⁽²⁾ Thread pitch minimum (mm)

⁽³⁾ Thread pitch maximum (mm)

For tools, see pages: PCAD RE/LE-JHP (301) • PCADR/L (300) • PCADR/L-JHP (301) • PCHBR/L (302) • PCHPR/L (300) • PCHR/L-24 (297) • PCHR/L-24-JHP (298) • PCHR/L-24-JHP-MC (298)



PENTA 24-WT

Precision Ground Pentagonal
External Threading Inserts
with a Whitworth 55° Partial Profile

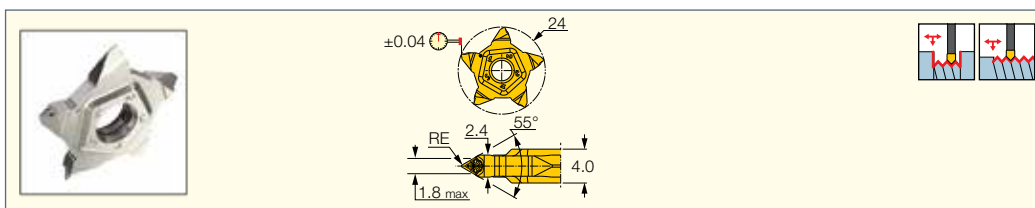

Dimensions				IC908
Designation	TPIX ⁽²⁾	TPIN ⁽³⁾	RE	
PENTA 24A-WT-0.15 ⁽¹⁾	19.00	14	0.15	●
PENTA 24A-WT-0.05 ⁽¹⁾	48.00	14	0.05	●

• TPIN=6.4/D(inch) D-nominal thread diameter (inch)

⁽¹⁾ Flat rake (without a chipformer)

⁽²⁾ Threads per inch maximum

⁽³⁾ Threads per inch minimum

For tools, see pages: PCAD RE/LE-JHP (301) • PCADR/L (300) • PCADR/L-JHP (301) • PCHBR/L (302) • PCHPR/L (300) • PCHR/L-24 (297) • PCHR/L-24-JHP (298) • PCHR/L-24-JHP-MC (298)



PENTA 34N-PB

Parting and Grooving Pentagonal Inserts for Parting Bearing Steel and Other Ductile Materials

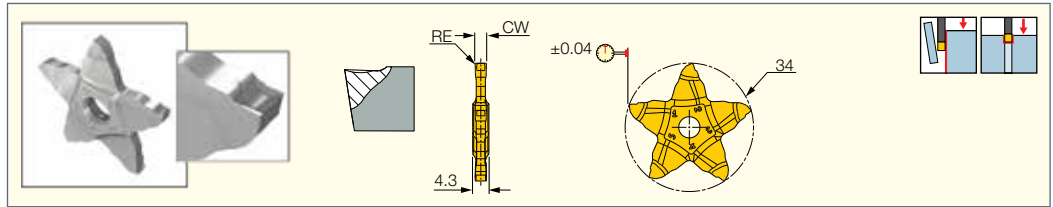

Designation	Dimensions					IC908	Recommended Machining Data
	CW	RE	CWTOL ⁽¹⁾	RETOL ⁽²⁾	CDX ⁽³⁾		
PENTA 34N150PB015	1.50	0.15	0.02	0.030	8.50	●	0.03-0.06
PENTA 34N200PB020	2.00	0.20	0.02	0.030	8.50	●	0.03-0.08
PENTA 34N300PB020	3.00	0.20	0.02	0.030	9.50	●	0.03-0.10

• For cutting speed recommendations and user guide, see pages 380-395

⁽¹⁾ Cutting width tolerance (+/-)

⁽²⁾ Corner radius tolerance (+/-)

⁽³⁾ For grooving and parting depths relative to part diameter, see page 310

For tools, see pages: PCADR/L (300) • PCADR/L 34N-RE (301) • PCHBR/L (302) • PCHPR/L (300) • PCHR/L-34 (299) • PCHR/L-34-JHP (299)



PENTA 34N-C

Inserts with 5 Cutting Edges for Parting and Grooving Hard Materials, Tough and General Applications

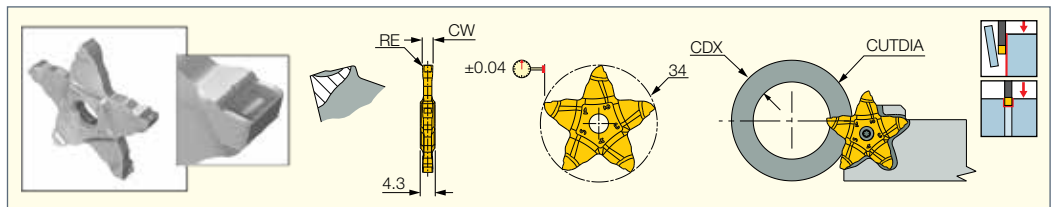

Designation	Dimensions					IC908	Recommended Machining Data
	CW	RE	CWTOL ⁽¹⁾	RETOL ⁽²⁾	CDX ⁽³⁾		
PENTA 34N150C015	1.50	0.15	0.00	0.030	8.00	●	0.03-0.07
PENTA 34N200C020	2.00	0.20	0.00	0.030	8.00	●	0.04-0.14
PENTA 34N200C100	2.00	1.00	0.00	0.050	8.00	●	0.05-0.16
PENTA 34N222C015	2.22	0.15	0.00	0.030	8.00	●	0.05-0.14
PENTA 34N230C020	2.30	0.20	0.00	0.030	8.00	●	0.05-0.14
PENTA 34N239C015	2.39	0.15	0.00	0.030	8.00	●	0.05-0.15
PENTA 34N239C120	2.39	1.20	0.00	0.050	8.00	●	0.05-0.18
PENTA 34N247C020	2.47	0.20	0.00	0.030	8.00	●	0.05-0.18
PENTA 34N250C020	2.50	0.20	0.00	0.030	8.00	●	0.05-0.18
PENTA 34N270C010	2.70	0.10	0.00	0.030	10.00	●	0.05-0.18
PENTA 34N287C020	2.87	0.20	0.00	0.030	10.00	●	0.05-0.18
PENTA 34N300C000	3.00	0.00	0.00	0.000	10.00	●	0.04-0.10
PENTA 34N300C020	3.00	0.20	0.02	0.030	10.00	●	0.06-0.22
PENTA 34N300C040	3.00	0.40	0.02	0.030	10.00	●	0.06-0.25
PENTA 34N300C150	3.00	1.50	0.02	0.050	10.00	●	0.06-0.20
PENTA 34N315C015	3.15	0.15	0.02	0.030	10.00	●	0.06-0.20
PENTA 34N318C020	3.18	0.20	0.02	0.030	10.00	●	0.06-0.22
PENTA 34N330C010	3.30	0.10	0.02	0.020	10.00	●	0.06-0.20
PENTA 34N348C020	3.48	0.20	0.02	0.030	10.00	●	0.06-0.25
PENTA 34N350C025	3.50	0.25	0.02	0.030	10.00	●	0.06-0.30
PENTA 34N398C020	3.98	0.20	0.02	0.030	10.00	●	0.06-0.30
PENTA 34N400C030	4.00	0.30	0.02	0.030	10.00	●	0.06-0.30

• For cutting speed recommendations and user guide, see pages 380-395

⁽¹⁾ Cutting width tolerance (+/-)

⁽²⁾ Corner radius tolerance (+/-)

⁽³⁾ For grooving and parting depths relative to part diameter, see page 310

For tools, see pages: PCADR/L (300) • PCADR/L 34N-RE (301) • PCHBR/L (302) • PCHPR/L (300) • PCHR/L-34 (299) • PCHR/L-34-JHP (299)

CW±0.02	CUTDIA as a Function of Parting / Grooving Depth (T) for PENTA 34 Inserts						
	T≤5.0	T≤6.0	T≤7.0	T≤8.0	T≤8.5	T≤9.0	T≤10.0
1.50 ≤ CW ≤ 2.69	N.L.	350	165	100	55	-	-
2.70 ≤ CW ≤ 4.00						55	20

CUTDIA for parting = 2 x CDX

N.L. = No Limit

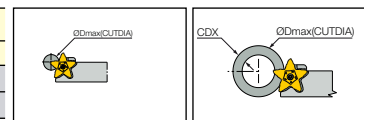

PENTA 34N-J

Inserts with 5 Cutting Edges for Parting and Grooving Soft Materials, Parting Tubes, Small and Thin-Walled Parts

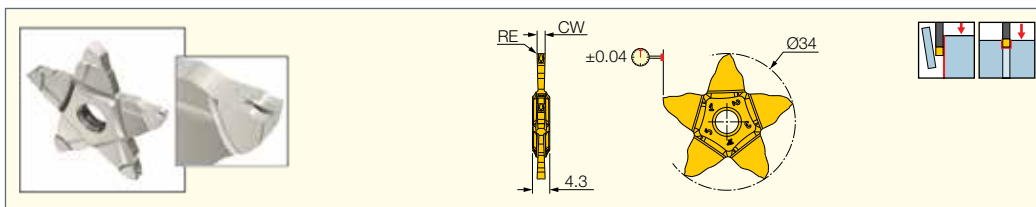

Designation	Dimensions					IC908	Recommended Machining Data
	CW	RE	CWTOL ⁽¹⁾	RETOL ⁽²⁾	CDX ⁽³⁾		f groove (mm/rev)
PENTA 34N150J015	1.50	0.15	0.02	0.000	8.50	●	0.03-0.10
PENTA 34N200J020	2.00	0.20	0.02	0.000	8.50	●	0.04-0.12
PENTA 34N200J100	2.00	1.00	0.02	0.050	8.50	●	0.05-0.12
PENTA 34N239J015	2.39	0.15	0.02	0.000	8.50	●	0.04-0.16
PENTA 34N239J120	2.39	1.20	0.02	0.050	8.50	●	0.06-0.16
PENTA 34N250J020	2.50	0.20	0.02	0.000	8.50	●	0.04-0.16
PENTA 34N270J010	2.70	0.10	0.02	0.000	10.00	●	0.04-0.16
PENTA 34N300J000	3.00	0.00	0.02	0.000	10.00	●	0.04-0.10
PENTA 34N300J020	3.00	0.20	0.02	0.000	10.00	●	0.04-0.16
PENTA 34N300J040	3.00	0.40	0.02	0.000	10.00	●	0.04-0.16
PENTA 34N300J150	3.00	1.50	0.02	0.050	10.00	●	0.06-0.20
PENTA 34N318J020	3.18	0.20	0.02	0.000	10.00	●	0.20-0.16

• Recessing is possible only with 2.39 mm and wider inserts • For cutting speed recommendations and user guide, see pages 380-395

⁽¹⁾ Cutting width tolerance (+/-)

⁽²⁾ Corner radius tolerance (+/-)

⁽³⁾ For grooving and parting depths relative to part diameter, see page 310

For tools, see pages: PCADR/L (300) • PCADR/L 34N-RE (301) • PCHBR/L (302) • PCHPR/L (300) • PCHR/L-34 (299) • PCHR/L-34-JHP (299)

GTGA

Precision Shallow Grooving Inserts with 3 Cutting Edges

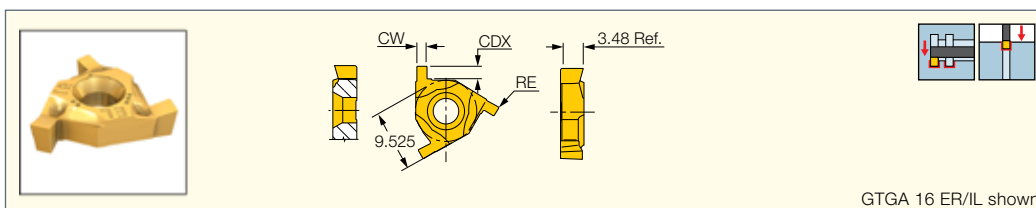

GTGA 16 ER/IL shown

Designation	Dimensions					Tough ↔ Hard		Recommended Machining Data
	CW	CDX	CWTOL ⁽¹⁾	RE	RETOL ⁽²⁾	IC528	IC508	f groove (mm/rev)
GTGA 16EL/IR 100	1.00	1.55	0.02	0.10	0.030	●	●	0.02-0.03
GTGA 16EL/IR 120	1.20	1.60	0.02	0.10	0.030	●	●	0.02-0.03
GTGA 16EL/IR 140	1.40	1.80	0.02	0.10	0.030	●	●	0.02-0.04
GTGA 16EL/IR 170	1.70	2.00	0.02	0.10	0.030	●	●	0.03-0.05
GTGA 16EL/IR 195	1.95	2.00	0.02	0.10	0.030	●	●	0.03-0.06
GTGA 16EL/IR 225	2.25	2.10	0.02	0.10	0.030	●	●	0.04-0.06
GTGA 16ER/IL 100	1.00	1.55	0.02	0.10	0.030	●	●	0.02-0.03
GTGA 16ER/IL 120	1.20	1.60	0.02	0.10	0.030	●	●	0.02-0.03
GTGA 16ER/IL 140	1.40	1.80	0.02	0.10	0.030	●	●	0.02-0.04
GTGA 16ER/IL 170	1.70	2.00	0.02	0.10	0.030	●	●	0.03-0.05
GTGA 16ER/IL 195	1.95	2.00	0.02	0.10	0.030	●	●	0.03-0.06
GTGA 16ER/IL 225	2.25	2.10	0.02	0.10	0.030	●	●	0.04-0.06

• Inserts for right-hand external grooving can be used as left-hand internal grooving • Use with anvil AE 16-0 on external tools and with anvil AI 16-0 on internal tools

• For cutting speed recommendations and user guide, see pages 380-395

⁽¹⁾ Cutting depth maximum

⁽²⁾ Cutting width tolerance (+/-)

For tools, see pages: C#-SER/L (653) • SER-D (654) • SER/L (652) • SIR/L (655)

GTMA
Utility Shallow Grooving Inserts
with 3 Cutting Edges

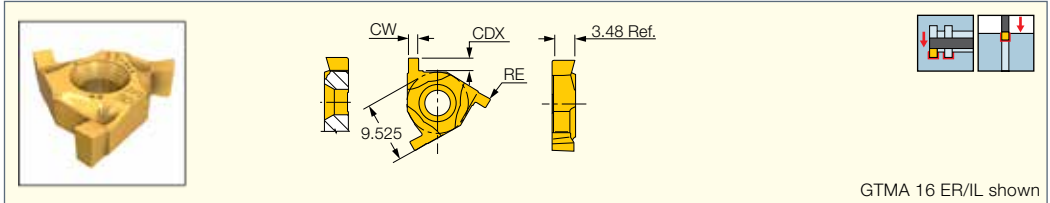

GTMA 16 ER/IL shown

Designation	Dimensions					IC508	Recommended Machining Data
	CW	CDX	CWTOL ⁽¹⁾	RE	RETOL ⁽²⁾		f groove (mm/rev)
GTMA 16ER/IL 120	1.20	1.60	0.05	0.10	0.050	●	0.02-0.03
GTMA 16ER/IL 140	1.40	1.80	0.05	0.10	0.050	●	0.02-0.04
GTMA 16ER/IL 160	1.60	2.00	0.05	0.10	0.050	●	0.03-0.05
GTMA 16ER/IL 175	1.75	2.00	0.05	0.10	0.050	●	0.03-0.05
GTMA 16ER/IL 195	1.95	2.00	0.05	0.10	0.050	●	0.03-0.06
GTMA 16ER/IL 222	2.22	2.10	0.05	0.10	0.050	●	0.04-0.06

- Inserts for right-hand external grooving can be used as left-hand internal grooving
- Use with anvil AE 16-0 on external tools and with anvil AI 16-0 on internal tools
- For cutting speed recommendations and user guide, see pages 380-395

⁽¹⁾ Cutting depth maximum

⁽²⁾ Cutting width tolerance (+/-)

For tools, see pages: C#-SER/L (653) • SER/L (652) • SIR/L (655)

HEAVY DUTY





THDR/L-IQ
External Holders for Wide Grooving Inserts

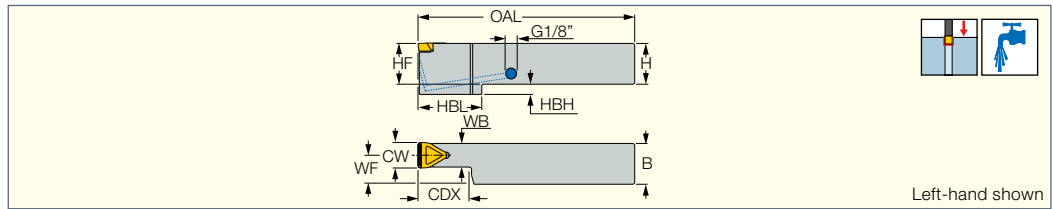

Left-hand shown

Designation	CW	CDX ⁽¹⁾	H	HF	B	OAL	WB	WF	HBH	HBL
THDR/L 2525-10T20-IQ	10.00	20.00	25.0	25.0	25.0	170.00	9.20	20.40	8.0	30.0
THDR/L 3232-10T20-IQ	10.00	20.00	32.0	32.0	32.0	170.00	9.20	27.40	8.0	30.0
THDR/L 2525-12T20-IQ	12.00	20.00	25.0	25.0	25.0	170.00	11.00	19.50	8.0	30.0
THDR/L 3232-12T20-IQ	12.00	20.00	32.0	32.0	32.0	170.00	11.00	26.50	8.0	30.0
THDR/L 2525-14T20-IQ	14.00	20.00	25.0	25.0	25.0	170.00	13.00	18.50	8.0	30.0
THDR/L 3232-14T20-IQ	14.00	20.00	32.0	32.0	32.0	170.00	13.00	25.50	8.0	30.0
THDR/L 3232-16T40-IQ	16.00	40.00	32.0	32.0	32.0	170.00	14.80	24.60	8.0	48.0
THDR/L 4040-16T50-IQ	16.00	50.00	40.0	40.0	40.0	180.00	14.80	32.60	-	-
THDR/L 3232-18T40-IQ	18.00	40.00	32.0	32.0	32.0	170.00	16.50	23.80	8.0	48.0
THDR/L 4040-18T50-IQ	18.00	50.00	40.0	40.0	40.0	180.00	16.50	31.80	-	-
THDR/L 3232-20T40-IQ	20.00	40.00	32.0	32.0	32.0	170.00	18.00	23.00	8.0	48.0
THDR/L 4040-20T50-IQ	20.00	50.00	40.0	40.0	40.0	180.00	18.00	31.00	-	-

- For grooving only
- (1) Cutting depth maximum

For inserts, see pages: TIGER-IQ (315)



Spare Parts

Designation				
THDR/L 2525-10T20-IQ	PIN 5.5 INJ	SR M6-26392	BLD T15/S7	SW6-T
THDR/L 3232-10T20-IQ	PIN 5.5 INJ	SR M6-26392	BLD T15/S7	SW6-T
THDR/L 2525-12T20-IQ	PIN 5.5 INJ	SR M6-26392	BLD T15/S7	SW6-T
THDR/L 3232-12T20-IQ	PIN 5.5 INJ	SR M6-26392	BLD T15/S7	SW6-T
THDR/L 2525-14T20-IQ	PIN 5.5 INJ	SR M6-26392	BLD T15/S7	SW6-T
THDR/L 3232-14T20-IQ	PIN 5.5 INJ	SR M6-26392	BLD T15/S7	SW6-T
THDR/L 3232-16T40-IQ	PIN 6.5 INJ 7000944	SR M8-26393	BLD T20/S7	SW6-T
THDR/L 4040-16T50-IQ	PIN 6.5 INJ 7000944	SR M8-26393	BLD T20/S7	SW6-T
THDR/L 3232-18T40-IQ	PIN 6.5 INJ 7000944	SR M8-26393	BLD T20/S7	SW6-T
THDR/L 4040-18T50-IQ	PIN 6.5 INJ 7000944	SR M8-26393	BLD T20/S7	SW6-T
THDR/L 3232-20T40-IQ	PIN 6.5 INJ 7000944	SR M8-26393	BLD T20/S7	SW6-T
THDR/L 4040-20T50-IQ	PIN 6.5 INJ 7000944	SR M8-26393	BLD T20/S7	SW6-T



THBR/L/N-IQ
Blades Carrying Cartridges for Wide Grooving Inserts

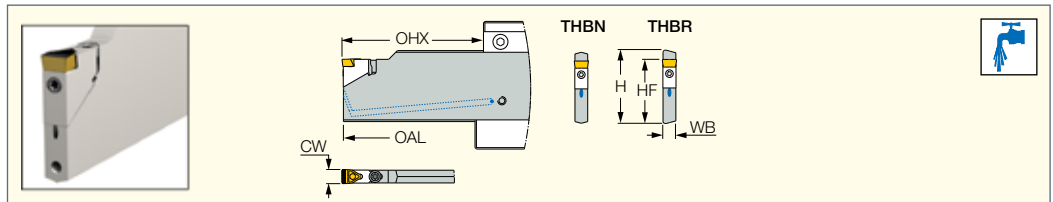

Designation	CW	OHX ⁽³⁾	CDX ⁽⁴⁾	WB	OAL	HF	H						
THBN 53K-10-IQ ⁽¹⁾	10.00	100.0	93.00	9.00	260.00	45.2	52.6	SR M5X3.5PL	SR M5X23-A90	BLD IP20/S7	SW6-T	SGC 340	SGCU 341
THBR/L 53K-12-IQ ⁽²⁾	12.00	100.0	93.00	10.80	260.00	45.2	52.6	SR M5X3.5PL	SR M5X23-A90	BLD IP20/S7	SW6-T	SGC 340	SGCU 341
THBR/L 53K-14-IQ ⁽²⁾	14.00	100.0	93.00	12.60	260.00	45.2	52.6	SR M5X3.5PL	SR M5X23-A90	BLD IP20/S7	SW6-T	SGC 340	SGCU 341

- For user guide, see pages 380-395
- (1) Cartridges have to be ordered separately.
- (2) For best performance use SGTBU...-14 holder blocks
- (3) Maximum overhang
- (4) If workpiece diameter is smaller than 200 mm, then CDX=98, if workpiece diameter is larger than 200 mm, then CDX=93.

For tools, see pages: CR THDN-IQ (315)

CR THDN-IQ
Cartridges for Blades Carrying
Wide Grooving Inserts

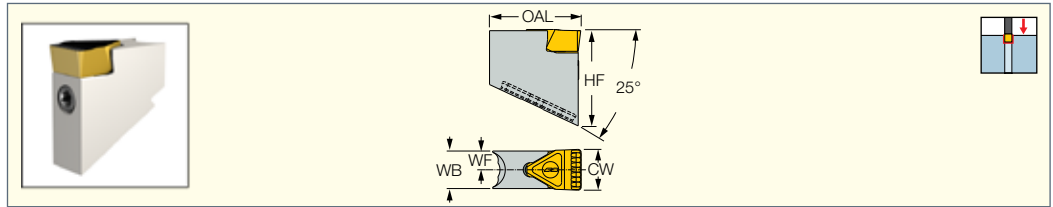

Designation	CW	WF	HF	OAL	WB				
CR THDN-10-IQ	10.00	4.60	24.0	22.60	9.20	SR M6-26392	PIN 5.5 INJ	BLD T15/S7	SW6-T
CR THDN-12-IQ	12.00	5.50	23.7	23.60	11.00	SR M6-26392	PIN 5.5 INJ	BLD T15/S7	SW6-T
CR THDN-14-IQ	14.00	6.50	23.7	24.20	13.00	SR M6-26392	PIN 5.5 INJ	BLD T15/S7	SW6-T

• For user guide, see pages 380-395
 For inserts, see pages: TIGER-IQ (315)
 For holders, see pages: THBR/L/N-IQ (314)

TIGER-IQ
Utility Single-Ended Inserts
for External Heavy Grooving
and Deep Machining

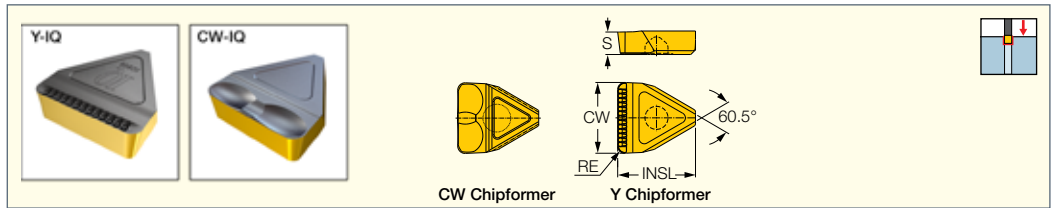

Designation	Dimensions						Tough ↔ Hard		Recommended Machining Data f groove (mm/rev)
	CW	RE	CWTOL ⁽¹⁾	RETOL ⁽²⁾	S	INSL	IC830	IC808	
TIGER 1008Y-IQ	10.00	0.80	0.08	0.050	5.05	13.30	●	●	0.20-0.35
TIGER 1212Y-IQ	12.00	1.20	0.08	0.050	5.05	14.00	●	●	0.20-0.40
TIGER 1415-CW-IQ	14.00	1.50	0.08	0.050	5.15	16.10	●	●	0.22-0.45
TIGER 1415Y-IQ	14.00	1.50	0.08	0.050	5.15	16.10	●	●	0.22-0.45
TIGER 1615Y-IQ	16.00	1.50	0.08	0.050	6.35	20.00	●	●	0.22-0.50
TIGER 1820Y-IQ	18.00	2.00	0.08	0.050	6.35	20.90	●	●	0.25-0.55
TIGER 2020-CW-IQ	20.00	2.00	0.08	0.050	6.35	22.00	●	●	0.25-0.60
TIGER 2020Y-IQ	20.00	2.00	0.08	0.050	6.35	22.00	●	●	0.25-0.60

• For cutting speed recommendations and user guide, see pages 380-395
⁽¹⁾ Cutting width tolerance (+/-)
⁽²⁾ Corner radius tolerance (+/-)

For tools, see pages: CR THDN-IQ (315) • THDR/L-IQ (314)



TGBHR/L

Toolholders for Heavy Duty Groove-Turn and Parting Applications

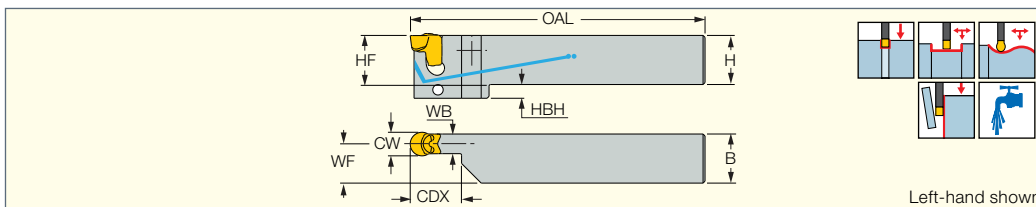

Left-hand shown

Designation	CW	H	HF	B	WB	OAL	CDX	WF	HBH
TGBHR/L 20C-6 (1)	6.00	20.0	20.0	20.0	5.20	135.00	12.00	17.40	5.0
TGBHR/L 25C-6 (1)	6.00	25.0	25.0	25.0	5.20	135.00	12.00	22.40	-
TGBHR/L 32C-6 (1)	6.00	32.0	32.0	32.0	5.20	150.00	12.00	29.40	-
TGBHR/L 25C-8	8.00	25.0	25.0	25.0	7.00	150.00	25.00	21.50	12.0
TGBHR/L 32C-8	8.00	32.0	32.0	32.0	7.00	170.00	30.00	28.50	5.0
TGBHR/L 25C-10	10.00	25.0	25.0	25.0	8.00	150.00	25.00	21.00	12.0
TGBHR/L 32C-10	10.00	32.0	32.0	32.0	8.00	170.00	30.00	28.00	5.0
TGBHR/L 25C-12	12.00	25.0	25.0	25.0	10.00	150.00	25.00	20.00	12.0
TGBHR/L 32C-12	12.00	32.0	32.0	32.0	10.00	170.00	30.00	27.00	5.0
TGBHR/L 25C-14T20	14.00	25.0	25.0	25.0	12.00	140.00	20.00	19.00	12.0
TGBHR/L 32C-14T40	14.00	32.0	32.0	32.0	12.00	170.00	40.00	26.00	5.0
TGBHR/L 40C-14T40	14.00	40.0	40.0	40.0	12.00	170.00	40.00	34.00	-

• The tools for the 14 mm inserts feature a 1/8" port thread for standard tube fittings • For user guide, see pages 380-395

(1) For detailed depth capacity, see table below

For inserts, see pages: TAG N-C/W/M (463) • TAG N-J/JS/JT (465) • TAG N-UT (467) • TAG R/L-C (464) • TAG R/L-J/JS (466) • TAGB/TAGBA (319)

Depth Capacity for TGBHR/L...C-6

CDX	28	26	24	22	20	18	16	14	12
CUTDIA	35	55	75	100	120	150	200	350	∞

CW ≥ 14

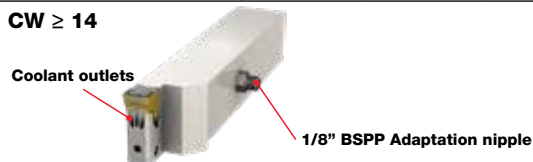

CW = 6-12

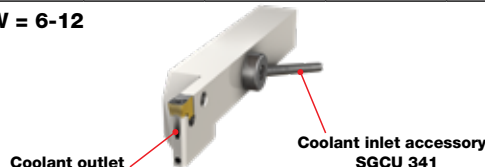

Spare Parts

Designation				
TGBHR/L 20C-6	ETG 5-7*	SGCU 341*		
TGBHR/L 25C-6	ETG 5-7*	SGCU 341*		
TGBHR/L 32C-6	ETG 5-7*	SGCU 341*		
TGBHR/L 25C-8	ETG 8-12*	SGCU 341*		
TGBHR/L 32C-8	ETG 8-12*	SGCU 341*		
TGBHR/L 25C-10	ETG 8-12*	SGCU 341*		
TGBHR/L 32C-10	ETG 8-12*	SGCU 341*		
TGBHR/L 25C-12	ETG 8-12*	SGCU 341*		
TGBHR/L 32C-12	ETG 8-12*	SGCU 341*		
TGBHR/L 25C-14T20	ETG 8-12*		PLG 1/8BSP TL360	JHP NIPPLE G1/8"-7/16"UNF*
TGBHL 32C-14T40	ETG 8-12*		PLG 1/8BSP TL360	JHP NIPPLE G1/8"-7/16"UNF*
TGBHR 32C-14T40	ETG 8-12*		PLG 1/8BSP TL360	JHP NIPPLE G1/8"-7/16"UNF*
TGBHR/L 40C-14T40	ETG 8-12*		PLG 1/8BSP TL360	JHP NIPPLE G1/8"-7/16"UNF*

* Optional, should be ordered separately

TGBHR/L-JHP

Grooving and Turning SUMO-GRIP Tools with Channels for High Pressure Coolant

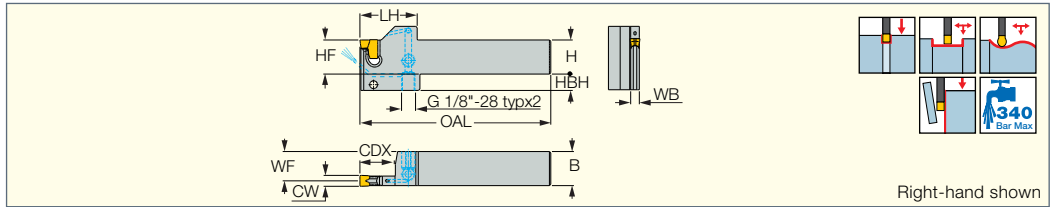

Right-hand shown

Designation	H	CW	HF	B	LH	WB	OAL	CDX ⁽¹⁾	WF	HBH
TGBHR/L 25-8-JHP	25.0	8.00	25.0	25.0	42.0	7.00	150.00	25.00	21.50	12.0
TGBHR/L 32-8-JHP	32.0	8.00	32.0	32.0	42.0	7.00	170.00	25.00	28.50	12.0

• For user guide see pages 380-400

⁽¹⁾ Cutting depth maximum

* Optional, should be ordered separately

For inserts, see pages: TAG N-C/W/M (463) • TAGB/TAGBA (319)

Flow Rate vs. Pressure

Designation	70 Bar Flow Rate (liters/min)	100 Bar Flow Rate (liters/min)	140 Bar Flow Rate (liters/min)
TGBHR/L-JHP	13-16	19-21	22-24

ETG 8-12 Extractor for 8 to 12.7 mm Inserts





TGFH/R/L

Blades with a Tangentially Oriented Pocket Carrying TANG-GRIP Single-Ended Inserts for Parting and Grooving

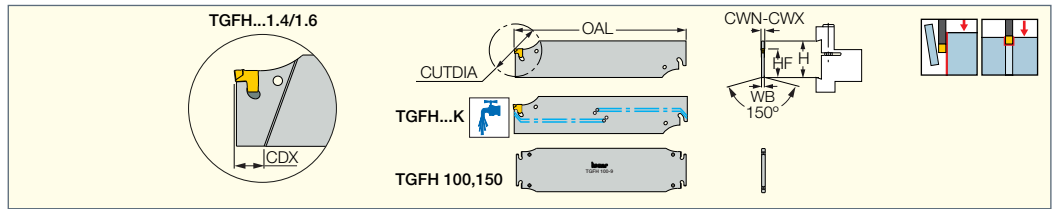

Designation	H	CWN ⁽²⁾	CWX ⁽³⁾	WB	OAL	CDX	HF	CUTDIA	CSP ⁽⁴⁾	Insert		
TGFH 19-1.4	19.0	1.40	1.40	1.05 ⁽⁵⁾	86.00	9.60	15.7	30.0	0	TAG 1.4	ETG 1.4/1.6*	
TGFH 19-1.6	19.0	1.60	1.60	1.30 ⁽⁶⁾	86.00	11.00	15.7	32.0	0	TAG 1.6	ETG 1.4/1.6*	
TGFH 19-2	19.0	1.80	2.40	1.65	86.00	-	15.7	38.0	0	TAG 2	ETG 2*	
TGFH 26-1.4	26.0	1.40	1.40	1.05 ⁽⁵⁾	110.00	8.30	21.4	29.0	0	TAG 1.4	ETG 1.4/1.6*	
TGFH 26-1.6	26.0	1.60	1.60	1.30 ⁽⁶⁾	110.00	10.00	21.4	35.0	0	TAG 1.6	ETG 1.4/1.6*	
TGFH 26-2	26.0	1.80	2.40	1.65	110.00	-	21.4	50.0	0	TAG 2	ETG 2*	
TGFH 26-3	26.0	2.80	3.50	2.50	110.00	-	21.4	75.0	0	TAG 3	ETG 3-4*	
TGFH 26K-3 ⁽¹⁾	26.0	2.80	3.50	2.50	110.00	-	21.4	75.0	1	TAG 3	ETG 3-4-SH*	SGC 340
TGFH 26-4	26.0	3.70	4.50	3.40	110.00	-	21.4	80.0	0	TAG 4	ETG 3-4*	
TGFH 26-5	26.0	4.70	5.50	4.00	150.00	-	21.4	80.0	0	TAG 5	ETG 5-7*	
TGFH 32-1.4	32.0	1.40	1.40	1.05 ⁽⁵⁾	150.00	7.10	24.8	29.0	0	TAG 1.4	ETG 1.4/1.6*	
TGFH 32-1.6	32.0	1.60	1.60	1.30 ⁽⁶⁾	150.00	10.00	24.8	38.0	0	TAG 1.6	ETG 1.4/1.6*	
TGFH 32-2	32.0	1.80	2.40	1.65 ⁽⁵⁾	150.00	-	24.8	50.0	0	TAG 2	ETG 2*	
TGFH 32-3	32.0	2.80	3.50	2.50	150.00	-	24.8	100.0	0	TAG 3	ETG 3-4*	
TGFH 32K-3 ⁽¹⁾	32.0	2.80	3.50	2.50	150.00	-	24.8	100.0	1	TAG 3	ETG 3-4-SH*	SGC 340
TGFH 32-4	32.0	3.70	4.50	3.40	150.00	-	24.8	100.0	0	TAG 4	ETG 3-4*	
TGFH 32K-4 ⁽¹⁾	32.0	3.70	4.50	3.40	150.00	-	24.8	100.0	1	TAG 4	ETG 3-4-SH*	SGC 340
TGFH 32-5	32.0	4.70	5.50	4.00	150.00	-	24.8	120.0	0	TAG 5	ETG 5-7*	
TGFH 32-6	32.0	5.70	6.50	5.20	150.00	-	24.8	120.0	0	TAG 6	ETG 5-7*	
TGFH 32-7	32.0	6.80	7.50	6.00	148.00	-	24.8	120.0	0	TAG 7	ETG 5-7*	
TGFH 45-3	45.0	2.80	3.50	2.50	225.00	-	38.1	160.0	0	TAG 3	ETG 3-4*	
TGFH 45-4	45.0	3.70	4.50	3.40	225.00	-	38.1	160.0	0	TAG 4	ETG 3-4*	
TGFH 45-5	45.0	4.70	5.50	4.00	225.00	-	38.1	160.0	0	TAG 5	ETG 5-7*	
TGFH 45-6	45.0	5.70	6.50	5.20	225.00	-	38.1	160.0	0	TAG 6	ETG 5-7*	
TGFH 45-7	45.0	6.80	7.50	6.00	225.00	-	38.1	160.0	0	TAG 7	ETG 5-7*	
TGFH 52-7	52.6	6.80	7.50	6.00	190.00	-	45.2	190.0	0	TAG 7	ETG 5-7*	
TGFH 53-7	52.6	6.80	7.50	6.00	260.00	-	45.2	220.0	0	TAG 7	ETG 5-7*	
TGFH 52K-8 ⁽¹⁾	52.6	7.70	8.50	7.20	190.00	-	45.2	190.0	1	TAG 8	ETG 8-12*	
TGFH 53K-8 ⁽¹⁾	52.6	7.70	8.50	7.20	260.00	-	45.2	215.0	1	TAG 8	ETG 8-12*	
TGFH 52K-9 ⁽¹⁾	52.6	8.70	10.00	8.20	190.00	-	45.2	190.0	1	TAG 9	ETG 8-12*	
TGFH 53K-9 ⁽¹⁾	52.6	8.70	10.00	8.20	260.00	-	45.2	215.0	1	TAG 9	ETG 8-12*	
TGFHR/L 53K-12 ⁽¹⁾	52.6	11.70	12.70	10.00	260.00	-	45.2	215.0	1	TAG 12	ETG 8-12*	
TGFH 100-9	100.0	8.70	10.00	8.20	460.00	-	92.5	450.0	0	TAG 9	ETG 8-12*	
TGFH 100-12	100.0	11.70	12.70	10.00	460.00	-	92.5	450.0	0	TAG 12	ETG 8-12*	
TGFH 150-12	150.0	11.70	12.70	10.00	610.00	-	142.5	600.0	0	TAG 12	ETG 8-12*	

• For user guide, see pages 380-395

⁽¹⁾ With coolant holes, the recommended coolant pressure is 10 bar min.; cooling tube SGCU 341 should be ordered separately

⁽²⁾ Minimum cutting width

⁽³⁾ Maximum cutting width

⁽⁴⁾ 0 - Without coolant supply, 1 - With coolant supply

⁽⁵⁾ Thickness beyond the D.O.C. area is 2.50 mm

⁽⁶⁾ Thickness beyond the D.O.C. area is 1.60 mm

* Optional, should be ordered separately

For inserts, see pages: TAG N-A (467) • TAG N-C/W/M (463) • TAG N-HF (463) • TAG N-J/JS/JT (465) • TAG N-LF (466) • TAG N-MF (464) • TAG N-UT (467) • TAG R/L-C (464) • TAG R/L-J/JS (466) • TAGB/TAGBA (319)

For holders, see pages: C#-TBK-R/L (591) • HSK A-WH-TBK-R/L (598) • SGTBF (587) • SGTBK (587) • SGTBR/L (587) • SGTBU/SGTBN (586) • UBHCR/L (587)

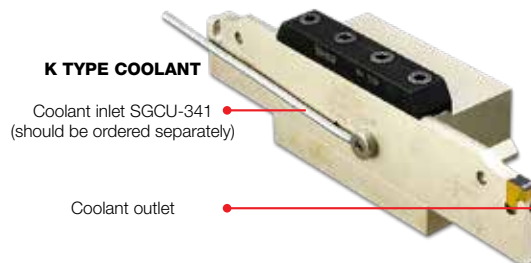

TAGB/TAGBA

Single-Ended Utility Inserts for Grooving, Turning and Parting

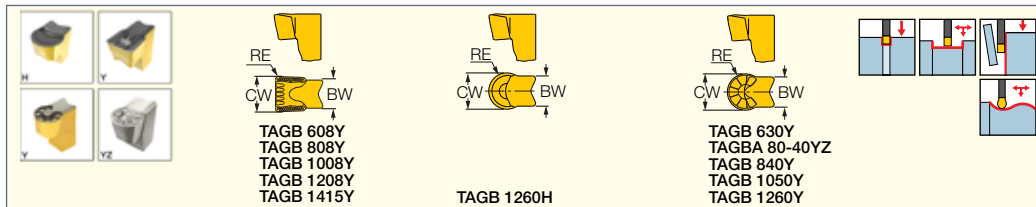

Designation	Dimensions					Tough ↔ Hard					Recommended Machining Data		
	CW	CWTOL ⁽³⁾	RE	RETOL ⁽⁴⁾	BW	IC8250	IC808	IC07	IC806	IC807	ap (mm)	f turn (mm/rev)	f groove (mm/rev)
TAGB 608Y	6.00	0.05	0.80	0.050	5.20		●		●		1.00-3.60	0.20-0.60	0.18-0.30
TAGB 630Y	6.00	0.05	3.00	0.050	5.20		●		●		0.00-3.00	0.25-0.55	0.18-0.32
TAGB 808Y	8.00	0.05	0.80	0.050	6.20	●	●		●	●	1.00-5.60	0.25-0.55	0.18-0.32
TAGB 840Y ⁽¹⁾	8.00	0.05	4.00	0.050	6.20	●	●		●	●	0.00-4.00	0.24-0.67	0.18-0.32
TAGBA 80-40YZ ⁽¹⁾	8.00	0.05	4.00	0.050	6.00			●			0.00-4.00	0.40-0.70	0.25-0.40
TAGB 1008Y	10.00	0.05	0.80	0.050	8.00	●	●				1.00-7.00	0.30-0.70	0.22-0.40
TAGB 1050Y ⁽²⁾	10.00	0.05	5.00	0.050	8.00	●	●				0.00-5.00	0.30-0.85	0.22-0.40
TAGB 1208Y	12.00	0.07	0.80	0.050	10.00	●	●				1.00-8.40	0.35-0.85	0.26-0.48
TAGB 1260Y ⁽²⁾	12.00	0.07	6.00	0.050	10.00	●	●				0.00-6.00	0.35-0.90	0.26-0.48
TAGB 1260H ⁽²⁾	12.00	0.07	6.00	0.050	10.00	●	●				0.00-6.00	0.45-1.00	0.35-0.55
TAGB 1415Y	14.00	0.07	1.50	0.050	12.00	●	●				1.80-8.40	0.35-0.85	0.26-0.50

• H-type chipformer with a negative T-land for machining heavy interrupted applications and cast iron parts

• For cutting speed recommendations and user guide, see pages 380-395

⁽¹⁾ Blade's pocket must be modified

⁽²⁾ Tool's pocket must be modified

⁽³⁾ Cutting width tolerance (+/-)

⁽⁴⁾ Corner radius tolerance (+/-)

For tools, see pages: Anti-Vibration Blades (268) • TGBHR/L (316) • TGBHR/L-JHP (317) • TGFH-JHP (451) • TGFH/R/L (318) • TGSU (417) • TGTR/L-IQ (459)

CUTGRIP

GHDR/L/N 12/14

External Tools for Wide Grooving Inserts

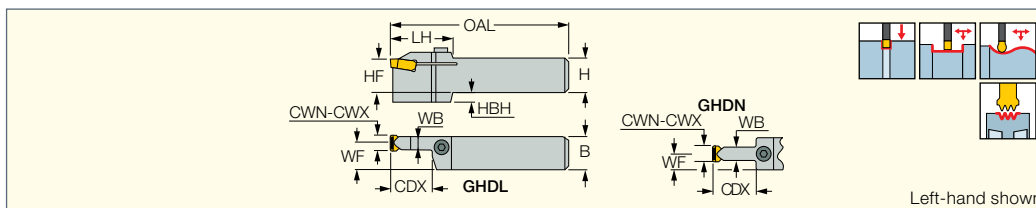

Designation	CWN ⁽¹⁾	CWX ⁽²⁾	CDX ⁽³⁾	H	HF	B	OAL	WF	WB	LH	HBH	Insert		
GHDR/L 32-12	12.00	14.53	30.00	32.0	32.0	32.0	170.00	27.30	9.50	50.0	-	GIMY 1260, TIGER 1453	SR M8X20 DIN912	HW 6.0
GHDR/L 2525-14T12	13.00	17.40	12.00	25.0	25.0	25.0	150.00	19.00	12.00	41.0	-	TIGER/GPV 14/16/17	SR M8X20 DIN912	HW 6.0
GHDR/L 3232-14T12	13.00	17.40	12.00	32.0	32.0	32.0	170.00	26.00	12.00	41.0	-	TIGER/GPV 14/16/17		
GHDR/L 3232-14T38	13.00	17.40	38.00	32.0	32.0	32.0	170.00	26.00	12.00	59.0	8.0	TIGER 14/16/17	SR M8X20 DIN912	HW 6.0
GHDN 3232-14T38	13.00	17.40	38.00	32.0	32.0	32.0	170.00	16.00	12.00	57.5	8.0	TIGER 14/16/17	SR M8X20 DIN912	HW 6.0
GHDR/L 4040-14T38	13.00	17.40	38.00	40.0	40.0	40.0	170.00	34.00	12.00	59.0	-	TIGER 14/16/17	SR M8X20 DIN912	HW 6.0
GHDN 4040-14T45	14.50	17.40	45.00	40.0	40.0	40.0	170.00	20.00	12.00	55.5	-	TIGER 14/16/17	SR 76-1289	HW 5.0

• For user guide, see pages 380-395

⁽¹⁾ Minimum cutting width

⁽²⁾ Maximum cutting width

⁽³⁾ Cutting depth maximum

For inserts, see pages: GIMY 1260 (274) • GPV (288) • TIGER (320)

CUTGRIP

CGHR/L-12-14D

Deep Machining Screw-Clamped Blades for Wide Grooving and Heavy Turning Applications

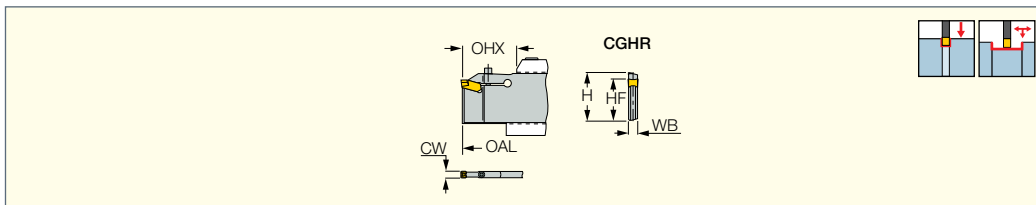

Designation	CWN ⁽¹⁾	CWX ⁽²⁾	OHX ⁽³⁾	CDX ⁽⁴⁾	WB	OAL	HF	H		
CGHR/L 53-12D	12.00	14.50	100.0	93.00	9.50	260.00	45.0	52.6	SR 76-4002	HW 5.0
CGHR/L 53-14D	12.50	17.40	100.0	93.00	11.10	260.00	45.0	52.6	SR M6X25 DIN912	HW 5.0

• For user guide, see pages 380-395

⁽¹⁾ Minimum cutting width

⁽²⁾ Maximum cutting width

⁽³⁾ Minimum overhang • When using a double-ended insert, grooving depth is limited by the insert

⁽⁴⁾ If workpiece diameter is smaller than 200 mm, then CDX=98, if workpiece diameter is larger than 200 mm, then CDX=93.

For inserts, see pages: GIMY 1260 (274) • TIGER (320)

For holders, see pages: SGTBK (587) • SGTBU/SGTBN (586)

CUTGRIP

TIGER

Utility Single-Ended Inserts for External Heavy Grooving and Deep Machining

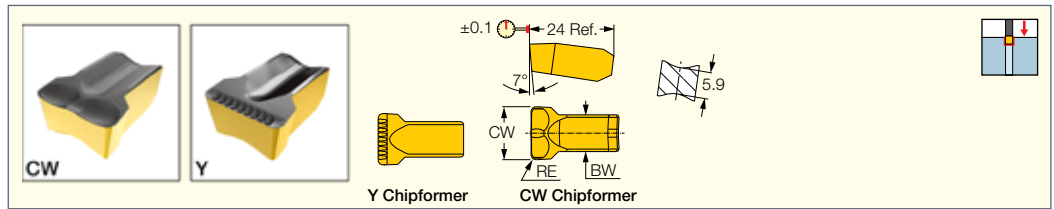

Designation	Dimensions						Tough ↔ Hard			Recommended Machining Data
	CW	CWTOL ⁽¹⁾	RE	RETOL ⁽²⁾	BW	INSL	IC830	IC808	IC20	
TIGER 1453-152	14.53	0.08	1.52	0.050	10.00	24.00	●	●	●	0.22-0.44
TIGER 1453-152-CW	14.53	0.08	1.52	0.050	10.00	24.00		●		0.15-0.50
TIGER 16.63-1.52	16.63	0.02	1.52	0.050	12.70	24.00		●		0.25-0.50
TIGER 1740-200	17.40	0.08	2.00	0.100	12.70	24.00		●		0.26-0.52

• For cutting speed recommendations and user guide, see pages 380-395

⁽¹⁾ Cutting width tolerance (+/-)

⁽²⁾ Corner radius tolerance (+/-)

For tools, see pages: CGHR/L-12-14D (319) • GHDR/L/N 12/14 (319)

CUTGRIP

THDR/L/N

External Holders for Wide Grooving Inserts

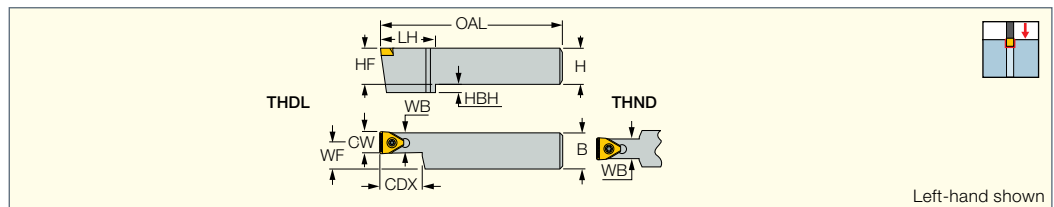

Designation	CW	CDX ⁽¹⁾	H	HF	B	OAL	WB	WF	HBH	LH	Insert			
THDR/L 4040-17T45	17.00	45.00	40.0	40.0	40.0	170.00	15.00	32.50	-	-	TIGERV 1740	SR 14-519	BLD T20/M7	SW6-T
THDR/L 3232-17T38	17.00	38.00	32.0	32.0	32.0	170.00	16.00	24.00	8.0	50.0	TIGERV 1740	SR 14-519	BLD T20/M7	SW6-T
THDR/L 3232-20T38	20.06	38.00	32.0	32.0	32.0	170.00	17.50	23.30	8.0	50.0	TIGERV 2006	SR 14-519	BLD T20/M7	SW6-T
THDR/L 4040-20T45	20.06	45.00	40.0	40.0	40.0	170.00	17.50	31.30	-	-	TIGERV 2006	SR 14-519	BLD T20/M7	SW6-T
THDN 3232-20T38	20.06	38.00	32.0	32.0	32.0	170.00	17.50	16.00	8.0	50.0	TIGERV 2006	SR 14-519	BLD T20/M7	SW6-T
THDN 4040-20T45	20.06	45.00	40.0	40.0	40.0	170.00	17.50	20.00	-	-	TIGERV 2006	SR 14-519	BLD T20/M7	SW6-T

• For grooving only

⁽¹⁾ Cutting depth maximum

For inserts, see pages: TIGERV (320)

CUTGRIP

TIGERV

Utility Single-Ended Inserts for External Heavy Grooving and Deep Machining

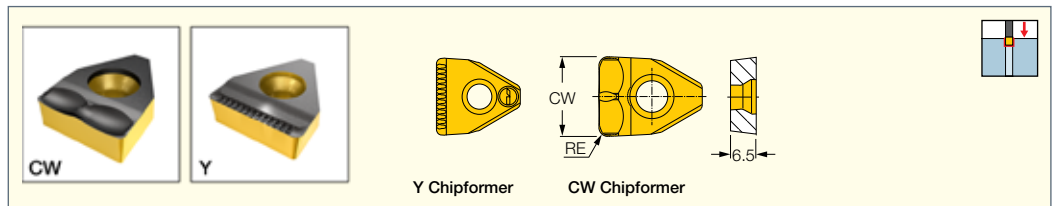

Designation	Dimensions				Tough ↔ Hard			Recommended Machining Data
	CW	RE	CWTOL ⁽¹⁾	RETOL ⁽²⁾	IC830	IC808	IC20	
TIGERV 1700-200-CW	17.00	2.00	0.08	0.050		●		0.20-0.60
TIGERV 2006-152	20.06	1.52	0.08	0.050	●	●	●	0.30-0.60

• For cutting speed recommendations and user guide, see pages 380-395

⁽¹⁾ Cutting width tolerance (+/-)

⁽²⁾ Corner radius tolerance (+/-)

For tools, see pages: THDR/L/N (320)

PCHR/L-27-JHP

Tools Carrying Pentagonal Wide Inserts for Specially Tailored Profiles

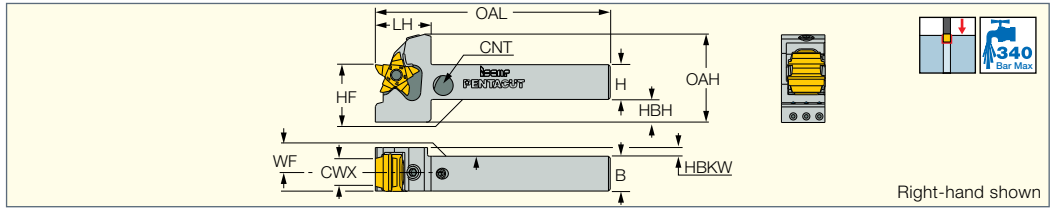

Right-hand shown

Designation	CWX ⁽¹⁾	WF	H	HF	OAH	B	HBKW	OAL	LH	HBH	CNT
PCHR/L 20-27-JHP	20.00	9.30	20.0	20.0	50.4	20.0	5.0	135.00	32.0	13.0	G1/4x10
PCHR/L 25-27-JHP	20.00	14.30	25.0	25.0	50.4	25.0	0.0	135.00	32.0	8.0	G1/4x10

⁽¹⁾ Maximum cutting width

For holders, see pages: C#-ADE (673) • C#-ADES (674) • C#-ASHA (673) • C#-ASHR/L (672) • C#-ASHR/L-45 (673) • C#-ASHR/L-45-HPMC (675) • C#-ASHR/L-HPMC (675) • HSK A-WH-ASHR/L-1 (677) • HSK A63WH-ASHN-45 (676) • HSK A63WH-ASHR/L-2 (677) • HSK A63WH-ASHR/L-3 (677) • HSK A63WH-ASHR/L-45 (677)

Spare Parts

Designation	
PCHR/L-27-JHP	HW 4.0

PENTAS 27-20 blank

Blank Insert with 5 Wide Cutting Edges for the Production of Special Profile Contours

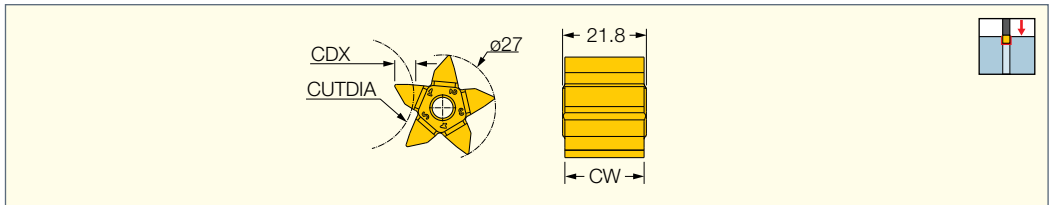

Designation	Dimensions		IC08
	CW	CDX	
PENTAS 27-20FT	20.00	4.00	•

For tools, see pages: PCHR/L-27-JHP (321)



INTERNAL TOOLS AND INSERTS



CUTGRIP

GEHIMR/L

Internal Machining Boring Bars with Coolant Holes for Insert Widths Less than 1.9 mm

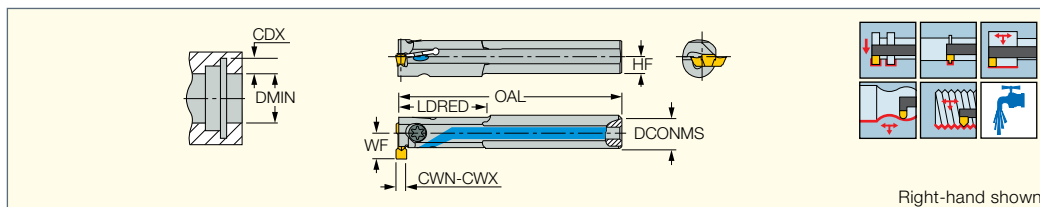

Right-hand shown

Designation	CWN ⁽¹⁾	CWX ⁽²⁾	DCONMS	DMIN	CDX ⁽³⁾	OAL	LDRED	WF	HF	CND ⁽⁴⁾			
GEHIMR/L 10-13	0.80	1.90	10.00	12.50	2.50	125.00	25.0	7.60	5.0	3.5 mm	SR 16-236	T-15/5	
GEHIMR/L 12-14	0.80	1.90	12.00	14.00	2.50	150.00	35.0	9.00	6.0	6.0 mm	SR 16-236	T-15/5	
GEHIMR/L 16-13	0.80	1.90	16.00	12.50	2.50	125.00	20.0	10.60	7.5	M6 ⁽⁵⁾	SR 16-236	T-15/5	PL 16
GEHIMR/L 16-14	0.80	1.90	16.00	14.00	2.50	125.00	25.0	10.90	7.5	M6 ⁽⁵⁾	SR 16-236	T-15/5	PL 16
GEHIMR/L 16-16	0.80	1.90	16.00	16.00	2.50	160.00	40.0	10.50	7.5	M6 ⁽⁵⁾	SR M5-04451	T-20/5	PL 16

• For user guide, see pages 380-395

- (1) Minimum cutting width
- (2) Maximum cutting width
- (3) Cutting depth maximum
- (4) Coolant inlet diameter
- (5) Plastic seal with M6 thread.

For inserts, see pages: GEPI (327) • GEPI (W<M) (327) • GEPI-MT (329) • GEPI-RX/LX (328) • GEPI-WT (329)

CUTGRIP

GEHIMR/L-SC

Internal Machining Solid Carbide Bars with Coolant Holes for Insert Widths Less than 1.9 mm

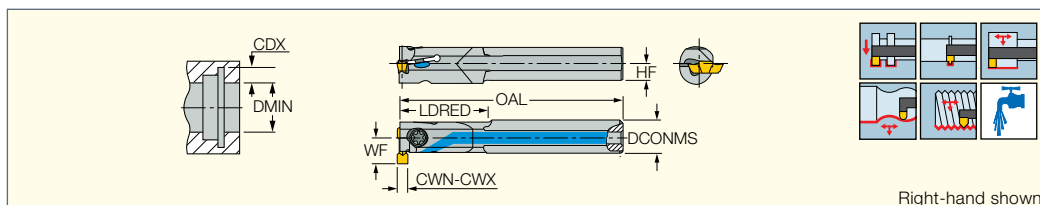

Right-hand shown

Designation	CWN ⁽¹⁾	CWX ⁽²⁾	DCONMS	DMIN	CDX ⁽³⁾	OAL	LDRED	WF	HF	Inlet			
GEHIMR/L 10SC-13	0.80	1.90	10.00	12.50	2.50	125.00	30.0	7.60	5.0	3.5 mm	SR 16-236	T-15/5	
GEHIMR/L 12SC-14	0.80	1.90	12.00	14.00	2.50	125.00	40.0	9.00	6.0	6.0 mm	SR 16-236	T-15/5	
GEHIMR/L 16SC-13	0.80	1.90	16.00	12.50	2.50	125.00	35.0	10.60	7.5	M6 ⁽⁴⁾	SR 16-236	T-15/5	PL 16
GEHIMR/L 16SC-16	0.80	1.90	16.00	16.00	2.50	160.00	70.0	10.50	7.5	M6 ⁽⁴⁾	SR M5-04451	T-20/5	PL 16

• For user guide, see pages 380-395

- (1) Minimum cutting width
- (2) Maximum cutting width
- (3) Cutting depth maximum
- (4) Plastic seal with M6 thread.

For inserts, see pages: GEPI (327) • GEPI (W<M) (327) • GEPI-MT (329) • GEPI-RX/LX (328) • GEPI-WT (329)



CUTGRIP

GEHIR/L Internal Machining Bars with Coolant Holes

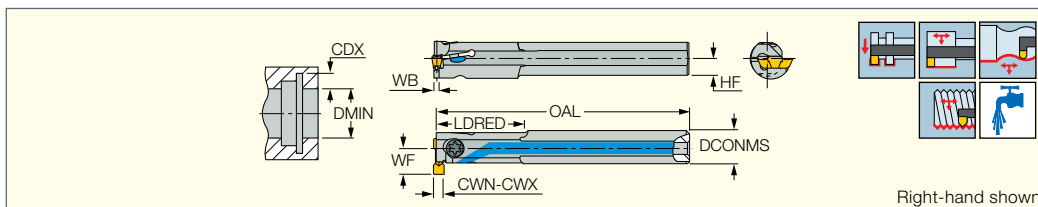

Right-hand shown

Designation	CWN ⁽¹⁾	CWX ⁽²⁾	DCONMS	DMIN	CDX	OAL	LDRED	WF	WB	HF	CND ⁽³⁾			
GEHIR/L 10-11.5-2-T3	1.90	2.40	10.00	11.50	3.00	125.00	25.0	8.80	1.60	5.0	3.5 mm	SR 14-513	T-8/5	
GEHIR/L 10-13-2-T2.4	1.90	2.40	10.00	12.50	2.40	125.00	25.0	7.50	1.60	5.0	3.5 mm	SR 16-236	T-15/5	
GEHIR/L 12-11.5-2-T3	1.90	2.40	12.00	11.50	3.00	125.00	20.0	11.60	1.60	6.0	6.0 mm	SR 14-513	T-8/5	
GEHIR/L 12-14-2-T2.6	1.90	2.40	12.00	14.00	2.60	150.00	35.0	9.10	1.60	6.0	6.0 mm	SR 16-236	T-15/5	
GEHIR/L 12-14-2-T4	1.90	2.40	12.00	14.00	4.00	150.00	35.0	10.30	1.60	6.0	6.0 mm	SR 14-562	T-10/5	
GEHIR/L 12-15-2-T6	1.90	2.40	12.00	15.00	6.00	150.00	29.0	12.30	1.60	6.0	6.0 mm	SR 14-513	T-8/5	
GEHIR/L 16-11.5-2-T3	1.90	2.40	16.00	11.50	3.00	125.00	20.0	11.60	1.60	7.5	M6 ⁽⁴⁾	SR 14-513	T-8/5	PL 16
GEHIR/L 16-13-2-T2.4	1.90	2.40	16.00	12.50	2.40	125.00	20.0	10.50	1.60	7.5	M6 ⁽⁴⁾	SR 16-236	T-15/5	PL 16
GEHIR/L 16-14-2-T2.6	1.90	2.40	16.00	14.00	2.60	125.00	25.0	11.00	1.60	7.5	M6 ⁽⁴⁾	SR 16-236	T-15/5	PL 16
GEHIR/L 16-14-2-T4	1.90	2.40	16.00	14.00	4.00	125.00	25.0	12.40	1.60	7.5	M6 ⁽⁴⁾	SR 14-562	T-10/5	PL 16
GEHIR/L 16-16-2-T3	1.90	2.40	16.00	16.00	3.00	160.00	40.0	11.00	1.60	7.5	M6 ⁽⁴⁾	SR M5-04451	T-20/5	PL 16
GEHIR/L 16-20-2-T8	1.90	2.40	16.00	20.00	8.00	160.00	40.0	16.10	1.60	7.5	M6 ⁽⁴⁾	SR M5-04451	T-20/5	PL 16
GEHIR/L 12-14-3-T2.6	2.40	3.20	12.00	14.00	2.60	150.00	35.0	9.10	2.00	6.0	6.0 mm	SR 16-236	T-15/5	
GEHIR/L 12-14-3-T4	2.40	3.20	12.00	14.00	4.00	150.00	35.0	10.30	2.00	6.0	6.0 mm	SR 14-562	T-10/5	
GEHIR/L 12-15-3-T6	2.40	3.20	12.00	15.00	6.00	150.00	29.0	12.30	2.00	6.0	6.0 mm	SR 14-513	T-8/5	
GEHIR/L 16-11.5-3-T3	2.40	3.20	16.00	11.50	3.00	125.00	20.0	11.60	2.00	7.5	M6 ⁽⁴⁾	SR 14-513	T-8/5	PL 16
GEHIR/L 16-13-3-T2.4	2.40	3.20	16.00	12.50	2.40	125.00	20.0	10.50	2.00	7.5	M6 ⁽⁴⁾	SR 16-236	T-15/5	PL 16
GEHIR/L 16-14-3-T2.6	2.40	3.20	16.00	14.00	2.60	125.00	25.0	11.00	2.00	7.5	M6 ⁽⁴⁾	SR 16-236	T-15/5	PL 16
GEHIR/L 16-14-3-T4	2.40	3.20	16.00	14.00	4.00	125.00	25.0	12.40	2.00	7.5	M6 ⁽⁴⁾	SR 14-562	T-10/5	PL 16
GEHIR/L 16-16-3-T3	2.40	3.20	16.00	16.00	3.00	160.00	40.0	11.00	2.00	7.5	M6 ⁽⁴⁾	SR M5-04451	T-20/5	PL 16
GEHIR/L 16-20-3-T8	2.40	3.20	16.00	20.00	8.00	160.00	40.0	16.10	2.00	7.5	M6 ⁽⁴⁾	SR M5-04451	T-20/5	PL 16

• For user guide, see pages 380-395

⁽¹⁾ Minimum cutting width

⁽²⁾ Maximum cutting width

⁽³⁾ Cutting depth maximum

⁽⁴⁾ Coolant inlet diameter

For inserts, see pages: GEMI (326) • GEMI (full radius) (326) • GEPI (327) • GEPI (full radius) (328) • GEPI-MT (329) • GEPI-WT (329)

CUTGRIP

GEHIR/L-SC Internal Machining Solid Carbide Bars with Coolant Holes

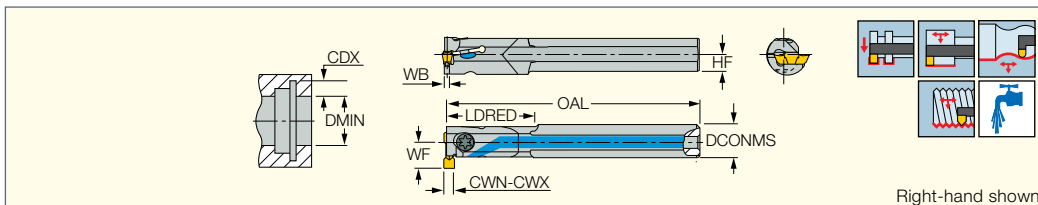

Right-hand shown

Designation	CWN ⁽¹⁾	CWX ⁽²⁾	DCONMS	DMIN	CDX ⁽³⁾	OAL	LDRED	WF	WB	HF	Inlet			
GEHIR/L 10SC-13-2	1.90	2.40	10.00	12.50	2.40	125.00	30.0	7.50	1.60	5.0	3.5 mm	SR 16-236	T-15/5	
GEHIR/L 12SC-14-2	1.90	2.40	12.00	14.00	2.60	125.00	40.0	9.10	1.60	6.0	6.0 mm	SR 16-236	T-15/5	
GEHIR/L 16SC-16-2	1.90	2.40	16.00	16.00	3.00	160.00	70.0	11.00	1.60	7.5	M6 ⁽⁴⁾	SR M5-04451	T-20/5	PL 16
GEHIR/L 12SC-14-3	2.40	3.20	12.00	14.00	2.60	125.00	40.0	9.10	2.00	6.0	6.0 mm	SR 16-236	T-15/5	
GEHIR/L 16SC-13-3	2.40	3.20	16.00	12.50	2.40	125.00	35.0	10.50	2.00	7.5	M6 ⁽⁴⁾	SR 16-236	T-15/5	PL 16
GEHIR/L 16SC-14-3	2.40	3.20	16.00	14.00	2.60	140.00	40.0	11.00	2.00	7.5	M6 ⁽⁴⁾	SR 16-236	T-15/5	PL 16
GEHIR/L 16SC-16-3	2.40	3.20	16.00	16.00	3.00	160.00	70.0	11.00	2.00	7.5	M6 ⁽⁴⁾	SR M5-04451	T-20/5	PL 16

• For user guide, see pages 380-395

⁽¹⁾ Minimum cutting width

⁽²⁾ Maximum cutting width

⁽³⁾ Cutting depth maximum

⁽⁴⁾ Plastic seal with M6 thread

For inserts, see pages: GEMI (326) • GEMI (full radius) (326) • GEPI (327) • GEPI (full radius) (328) • GEPI-MT (329) • GEPI-WT (329)

CUTGRIP

GEIUR/L

Undercutting and Turning Boring Bars with Coolant Holes

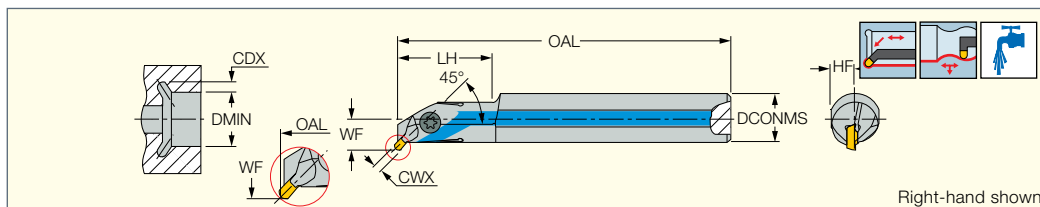

Designation	CWX ⁽¹⁾	DCONMS	DMIN	CDX ⁽²⁾	OAL	LH	WF	HF	CND ⁽³⁾			
GEIUR/L 12U	3.20	12.00	14.00	2.00	125.00	20.0	8.70	6.0	6.0 mm	SR 16-236 P	T-15/5	
GEIUR/L 16U	3.20	16.00	16.00	2.00	125.00	32.0	9.70	7.5	M6 ⁽⁴⁾	SR M5-04451	T-20/5	PL 16

• For profiling use GEPI (full radius) inserts only, for undercutting use GEPI - UN/UR/UL

⁽¹⁾ Maximum cutting width

⁽²⁾ Cutting depth maximum

⁽³⁾ Coolant inlet diameter

⁽⁴⁾ Plastic seal with M6 thread.

For inserts, see pages: GEPI (full radius) (328) • GEPI-UN/UR/UL (328)

CUTGRIP

GHAIR/L-GE

Bars with Coolant Holes for Internal Grooving and Turning Adapters

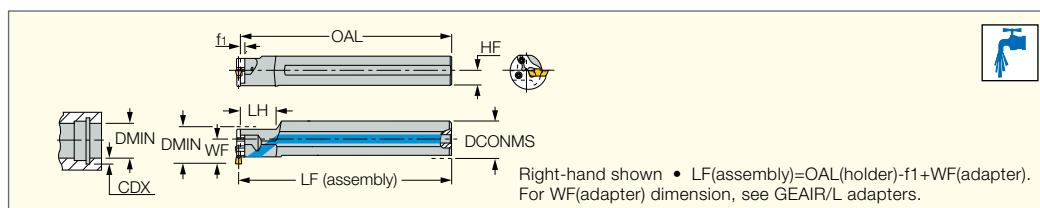

Right-hand shown • LF(assembly)=OAL(holder)-f1+WF(adapter). For WF(adapter) dimension, see GEAIR/L adapters.

Designation	DCONMS	LH	OAL	WF	HF	f ₁	Adapter			
GHAIR/L 16-20	16.00	-	150.00	11.50	7.5	2.4	GEAIR/L 20..	SR 76-2057	T-8/5	PL 16
GHAIR/L 20-20	20.00	20.0	150.00	13.50	9.0	2.4	GEAIR/L 20..	SR 76-2057	T-8/5	PL 20
GHAIR/L 25-20	25.00	25.0	200.00	16.00	11.5	2.4	GEAIR/L 20..	SR 76-2057	T-8/5	PL 25
GHAIR/L 32-20	32.00	32.0	200.00	19.50	14.5	2.4	GEAIR/L 20..	SR 76-2057	T-8/5	PL 32
GHAIR/L 20-25	20.00	-	150.00	14.50	9.0	2.4	GEAIR/L 25..	SR 16-236 P	T-15/5	PL 20
GHAIR/L 25-25	25.00	25.0	200.00	17.00	11.5	2.4	GEAIR/L 25..	SR 16-236 P	T-15/5	PL 25
GHAIR/L 32-25	32.00	32.0	200.00	20.50	14.5	2.4	GEAIR/L 25..	SR 16-236 P	T-15/5	PL 32

• For DMIN & CDX refer to GEAIR/L adapters

For tools, see pages: GEAIR/L (325)

CUTGRIP

GHAIR/L-SC-GE

Solid Carbide Bars with Coolant Holes for Internal Grooving and Turning Adapters

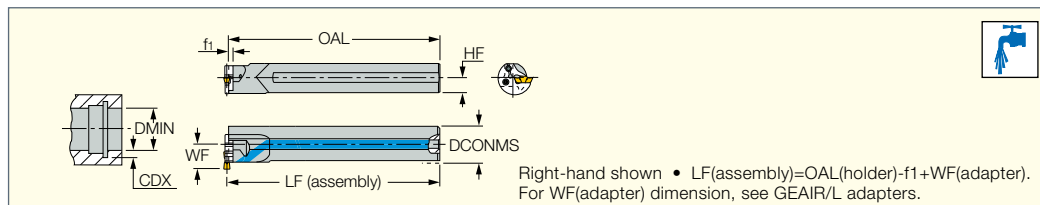

Right-hand shown • LF(assembly)=OAL(holder)-f1+WF(adapter). For WF(adapter) dimension, see GEAIR/L adapters.

Designation	DCONMS	OAL	WF	HF	f ₁	Adapter			
GHAIR/L 25SC-25	25.00	200.00	17.00	11.5	2.4	GEAIR/L 25-...	SR 16-236 P ^(a)	T-15/5 ^(b)	PL 25

• For DMIN & CDX refer to GEAIR/L adapters.

For tools, see pages: GEAIR/L (325)

CUTGRIP

GEAIR/L

Internal Grooving and Turning Adapters

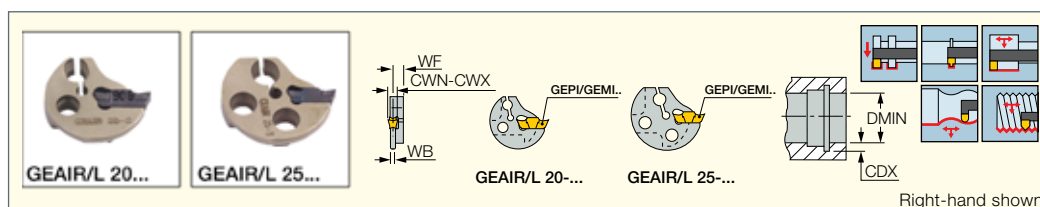

Right-hand shown

Designation	DMIN	CWN ⁽¹⁾	CWX ⁽²⁾	CDX	WF	WB
GEAIR/L 20-2	20.00	1.90	2.40	3.00	3.40	1.60
GEAIR/L 20-3	20.00	2.40	3.00	3.00	3.60	2.00
GEAIR/L 20-4	20.00	3.00	4.00	3.00	3.90	2.50
GEAIR/L 25-2	25.00	1.90	2.40	4.00	3.40	1.60
GEAIR/L 25-3	25.00	2.40	3.00	4.00	3.60	2.00
GEAIR/L 25-4	25.00	3.00	4.00	4.00	3.90	2.50

• When using TIPI inserts, toolholder seat needs to be modified according to insert profile to ensure clearance • For user guide, see pages 380-395

⁽¹⁾ Minimum cutting width

⁽²⁾ Maximum cutting width

For inserts, see pages: GEMI (326) • GEMI (full radius) (326) • GEPI (327) • GEPI (full radius) (328) • GEPI-MT (329) • GEPI-WT (329)

For holders, see pages: • GHAIR/L-GE (325) • GHAIR/L-SC-GE (325)

CUTGRIP

E-GEHIR / E-GHIR

Interchangeable Heads for Internal Grooving and Turning

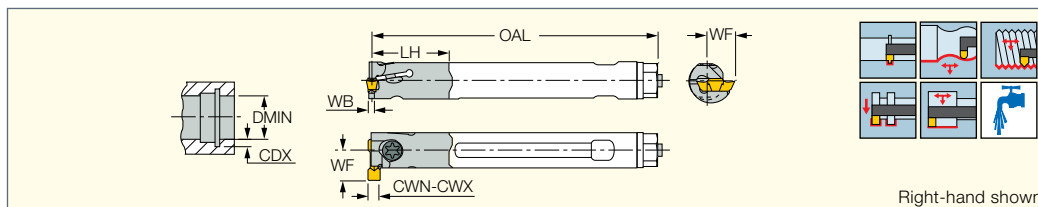

Right-hand shown

Designation	CWN ⁽¹⁾	CWX ⁽²⁾	DMIN	CDX	OAL	LH	WF	WB	Insert		
E12 GEHIR 16-1	1.50	1.90	16.00	2.20	174.00	21.0	9.00	1.20	GEPI, GEMI	SR M5-04451-L10.5	T-20/5
E12 GEHIR 16-2	1.90	2.40	16.00	2.20	174.00	21.0	9.00	1.60	GEPI, GEMI	SR M5-04451-L10.5	T-20/5
E12 GEHIR 16-3	2.40	3.00	16.00	2.20	174.00	21.0	9.00	2.00	GEPI, GEMI	SR M5-04451-L10.5	T-20/5
E16 GHIR 25-3	2.40	3.00	25.00	4.00	209.00	28.7	12.80	2.00	GIPI, GIMMY, GIF, TIPI	SR M5-04451	T-20/5

• Left-hand heads on request • The shank assembly is the same for right- and left-hand heads • For user guide, see pages 380-395

⁽¹⁾ Minimum cutting width

⁽²⁾ Maximum cutting width

For inserts, see pages: GEMI (326) • GEMI (full radius) (326) • GEPI (327) • GEPI (full radius) (328) • GEPI (W<M) (327) • GEPI-MT (329) • GEPI-WT (329) • GIMIY (332)

• GINI-E (334) • GIPI (335) • GIPI-E (333)

CUTGRIP

GEMI

Utility Double-Ended Inserts for Internal and External Grooving and Turning

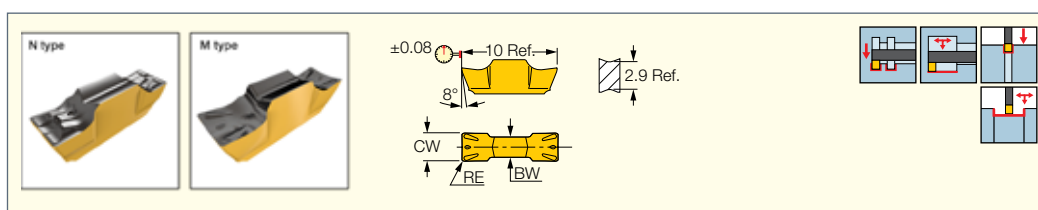

Designation	Dimensions					Tough ↔ Hard			Recommended Machining Data		
	CW	RE	CWTOL ⁽¹⁾	RETOL ⁽²⁾	BW	IC808	IC908	IC807	a _p (mm)	f turn (mm/rev)	f groove (mm/rev)
GEMI 2002N	2.00	0.20	0.02	0.050	1.60	●	●		0.25-0.80	0.05-0.10	0.04-0.08
GEMI 3002M	3.00	0.20	0.02	0.050	2.20	●	●		0.25-1.30	0.10-0.14	0.05-0.09
GEMI 3002N	3.00	0.20	0.02	0.050	2.20	●		●	0.25-1.00	0.07-0.12	0.04-0.08

• GEMI N inserts for ductile materials and low feed • DMIN for internal application=11.5 mm • For cutting speed recommendations and user guide, see pages 380-395

⁽¹⁾ Cutting width tolerance (+/-)

⁽²⁾ Corner radius tolerance (+/-)

For tools, see pages: E-GEHIR / E-GHIR (326) • GEAIR/L (325) • GEHIR/L (324) • GEHIR/L-SC (324) • GEHSR (356) • GEHSR/L-SL (356)

CUTGRIP

GEMI (full radius)

Utility Double-Ended Full Radius Inserts for Internal and External Grooving and Profiling

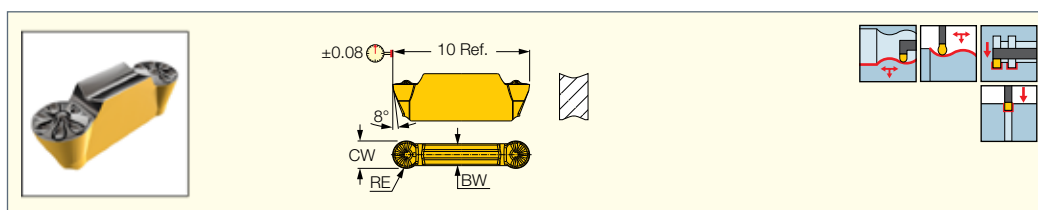

Designation	Dimensions					IC808	Recommended Machining Data		
	CW	RE	CWTOL ⁽¹⁾	RETOL ⁽²⁾	BW		a _p (mm)	f turn (mm/rev)	f groove (mm/rev)
GEMI 2010Y	2.00	1.00	0.02	0.050	1.60	●	0.10-1.00	0.06-0.12	0.03-0.08
GEMI 3015Y	3.00	1.50	0.04	0.050	2.20	●	0.10-1.50	0.10-0.18	0.05-0.10

• DMIN for internal application=11.5 mm • For cutting speed recommendations and user guide, see pages 380-395

⁽¹⁾ Cutting width tolerance (+/-)

⁽²⁾ Corner radius tolerance (+/-)

For tools, see pages: E-GEHIR / E-GHIR (326) • GEAIR/L (325) • GEHIR/L (324) • GEHIR/L-SC (324) • GEHSR (356) • GEHSR/L-SL (356)

CUTGRIP

GEPI (W<M)

Precision Ground Double-Ended Inserts for Internal Grooving

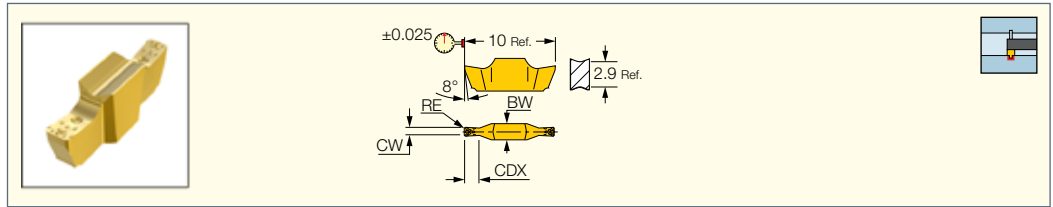

Designation	Dimensions						Tough ↔ Hard			Recommended Machining Data
	CW	RE	CWTOL ⁽¹⁾	RETOL ⁽²⁾	CDX	BW	IC528	IC08	IC908	
GEPI 1.00-0.10	1.00	0.10	0.00	0.030	1.60	1.80	●	●	●	f groove (mm/rev) 0.01-0.03
GEPI 1.00-0.50	1.00	0.50	0.00	0.030	1.60	1.80	●	●	●	0.01-0.04
GEPI 1.04-0.00	1.04	0.00	0.00	0.030	1.60	1.80	●	●	●	0.01-0.03
GEPI 1.20-0.00	1.20	0.00	0.00	0.030	1.80	1.80	●	●	●	0.01-0.03
GEPI 1.25-0.10	1.25	0.10	0.00	0.030	2.00	1.80	●	●	●	0.02-0.04
GEPI 1.40-0.00	1.40	0.00	0.00	0.030	2.00	1.80	●	●	●	0.02-0.04
GEPI 1.47-0.00	1.47	0.00	0.00	0.030	2.00	1.80	●	●	●	0.02-0.04
GEPI 1.50-0.10	1.50	0.10	0.00	0.030	2.00	1.80	●	●	●	0.02-0.04
GEPI 1.57-0.15	1.57	0.15	0.00	0.030	2.00	1.80	●	●	●	0.02-0.05
GEPI 1.70-0.05	1.70	0.05	0.02	0.030	2.50	1.80	●	●	●	0.02-0.05
GEPI 1.78-0.15	1.78	0.15	0.02	0.030	2.50	1.80	●	●	●	0.02-0.05

• Toolholder seat needs to be modified according to insert profile to ensure clearance • DMIN for internal application=11.5mm • For cutting speed recommendations and user guide, see pages 380-395

⁽¹⁾ Cutting width tolerance (+/-)

⁽²⁾ Corner radius tolerance (+/-)

For tools, see pages: E-GEHIR / E-GHIR (326) • GEHIMR/L (323) • GEHIMR/L-SC (323)

CUTGRIP

GEPI

Precision Ground Double-Ended Inserts for Internal and External Grooving

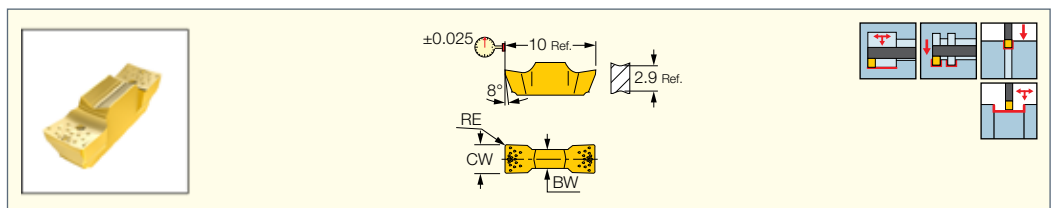

Designation	Dimensions						Tough ↔ Hard			Recommended Machining Data		
	CW	RE	CWTOL ⁽²⁾	RETOL ⁽³⁾	CDX	BW	IC528	IC08	IC908	a _p (mm)	f turn (mm/rev)	f groove (mm/rev)
GEPI 1.85-0.10 ⁽¹⁾	1.85	0.10	0.02	0.030	2.50	1.80	●	●	●	0.15-0.50	0.05-0.07	0.03-0.05
GEPI 1.96-0.10	1.96	0.10	0.02	0.030	2.50	1.80	●	●	●	0.15-0.50	0.05-0.07	0.03-0.05
GEPI 1.96-0.15	1.96	0.15	0.02	0.030	2.50	1.80	●	●	●	0.20-0.50	0.05-0.07	0.03-0.05
GEPI 2.00-0.10	2.00	0.10	0.02	0.030	9.00	1.80	●	●	●	0.15-0.60	0.05-0.07	0.03-0.05
GEPI 2.22-0.10	2.22	0.10	0.02	0.030	9.00	1.80	●	●	●	0.15-0.60	0.06-0.08	0.04-0.06
GEPI 2.22-0.15	2.22	0.15	0.02	0.030	9.00	1.80	●	●	●	0.20-0.60	0.06-0.08	0.04-0.06
GEPI 2.39-0.10	2.39	0.10	0.02	0.030	9.00	2.20	●	●	●	0.15-1.00	0.07-0.09	0.04-0.06
GEPI 2.39-0.15	2.39	0.15	0.02	0.030	9.00	2.20	●	●	●	0.20-1.00	0.07-0.09	0.04-0.06
GEPI 2.47-0.20	2.47	0.20	0.02	0.030	9.00	2.20	●	●	●	0.25-1.10	0.08-0.11	0.04-0.07
GEPI 2.50-0.10	2.50	0.10	0.02	0.030	9.00	2.20	●	●	●	0.15-1.10	0.07-0.09	0.04-0.07
GEPI 2.50-0.20	2.50	0.20	0.02	0.030	9.00	2.20	●	●	●	0.25-1.10	0.08-0.11	0.05-0.08
GEPI 2.70-0.20	2.70	0.20	0.02	0.030	9.00	2.20	●	●	●	0.25-1.20	0.09-0.12	0.05-0.08
GEPI 3.00-0.20	3.00	0.20	0.02	0.030	9.00	2.20	●	●	●	0.25-1.30	0.10-0.14	0.05-0.09
GEPI 3.18-0.20	3.18	0.20	0.02	0.030	9.00	2.20	●	●	●	0.25-1.40	0.11-0.14	0.06-0.10

• DMIN for internal application=11.5mm • For cutting speed recommendations and user guide, see pages 380-395

⁽¹⁾ Tool pocket should be modified

⁽²⁾ Cutting width tolerance (+/-)

⁽³⁾ Corner radius tolerance (+/-)

For tools, see pages: E-GEHIR / E-GHIR (326) • GEAIR/L (325) • GEHIMR/L (323) • GEHIMR/L-SC (323) • GEHIR/L (324) • GEHIR/L-SC (324) • GEHSR (356) • GEHSR/L-SL (356)

CUTGRIP

GEPI (full radius)

Precision Double-Ended Full Radius Inserts for Internal and External Profiling and Grooving

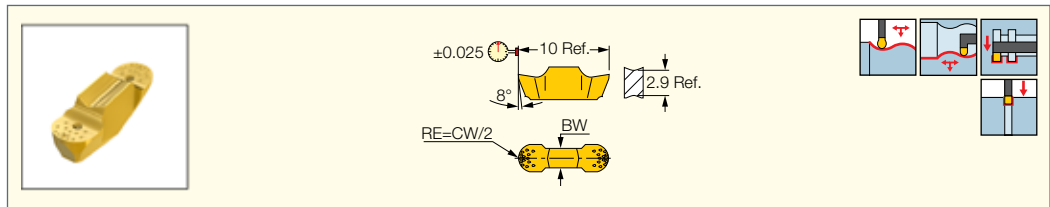

Designation	Dimensions						Tough ↔ Hard			Recommended Machining Data		
	CW	RE	CWTOL ⁽¹⁾	RETOL ⁽²⁾	CDX	BW	IC528	IC08	IC908	a _p (mm)	f turn (mm/rev)	f groove (mm/rev)
GEPI 2.00-1.00	2.00	1.00	0.02	0.050	5.00	1.80	●	●	●	0.00-0.60	0.08-0.12	0.04-0.07
GEPI 3.00-1.50	3.00	1.50	0.02	0.050	5.00	2.20	●	●	●	0.00-1.50	0.13-0.20	0.05-0.11
GEPI 3.18-1.59	3.18	1.59	0.02	0.050	5.00	2.20	●	●	●	0.00-1.59	0.13-0.21	0.06-0.11

• DMIN for internal application=11.5mm • For cutting speed recommendations and user guide, see pages 380-395

⁽¹⁾ Cutting width tolerance (+/-)

⁽²⁾ Corner radius tolerance (+/-)

For tools, see pages: E-GEHIR / E-GHIR (326) • GEAIR/L (325) • GEHIR/L (324) • GEHIR/L-SC (324) • GEHIUR/L (325) • GEHSR (356) • GEHSR/L-SL (356)

CUTGRIP

GEPI-RX/LX

Precision Double-Ended Inserts, for Internal Grooving Next to Shoulder

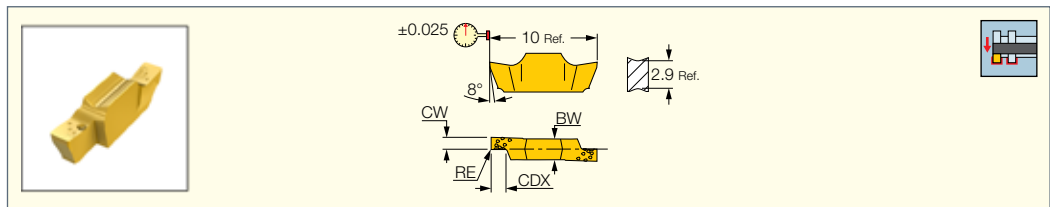

Designation	Dimensions						Tough ↔ Hard		Recommended Machining Data
	CW	RE	CWTOL ⁽¹⁾	RETOL ⁽²⁾	CDX	BW	IC528	IC908	f groove (mm/rev)
GEPI 0.80-0.00RX	0.80	0.00	0.02	0.030	1.50	1.80		●	0.01-0.02
GEPI 1.00-0.10 R/LX	1.00	0.10	0.02	0.030	1.50	1.80	●		0.01-0.03
GEPI 1.57-0.15RX	1.57	0.15	0.02	0.030	2.00	1.80		●	0.02-0.05

• Toolholder seat needs to be modified according to insert profile to ensure clearance • DMIN for internal application=11.5mm • For cutting speed recommendations and user guide, see pages 380-395

⁽¹⁾ Cutting width tolerance (+/-)

⁽²⁾ Corner radius tolerance (+/-)

For tools, see pages: GEHIMR/L (323) • GEHIMR/L-SC (323)

CUTGRIP

GEPI-UN/UR/UL

Precision Double-Ended Inserts for Internal Undercutting

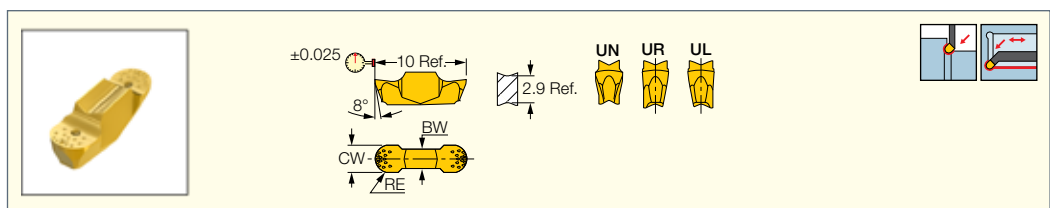

Designation	Dimensions						Tough ↔ Hard		Recommended Machining Data
	CW	RE	CWTOL ⁽¹⁾	RETOL ⁽²⁾	CDX	BW	IC528	IC08	f groove (mm/rev)
GEPI 3.00-1.50UN	3.00	1.50	0.02	0.050	2.00	2.20	●		0.03-0.12
GEPI 2.00-1.00UR/L	2.00	1.00	0.02	0.050	2.00	1.80	●	●	0.03-0.12

• For cutting speed recommendations and user guide, see pages 380-395

⁽¹⁾ Cutting width tolerance (+/-)

⁽²⁾ Corner radius tolerance (+/-)

For tools, see pages: GEHIUR/L (325)

ISCAR THREAD

CUTGRIP

GEPI-MT

Precision Ground Internal Double-Ended Threading Inserts with a 60° Partial Profile for General Applications

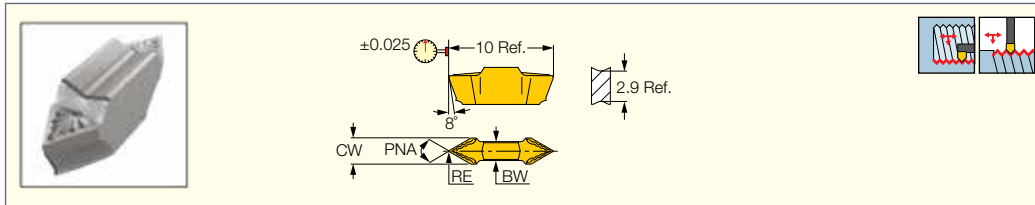

Designation	Dimensions							Tough ↔ Hard	
	CW	RE	RETOL ⁽¹⁾	PNA	BW	TPN ⁽²⁾	TPIX ⁽³⁾	IC08	IC908
GEPI 2.5-MT0.05	2.50	0.05	0.030	60	1.80	0.900	28.00	●	●

• Toolholder seat needs to be modified according to insert profile to ensure clearance • Pitch max 0.187xD, TPI min D/5.35 • D=Diameter of thread (pitch max<=CW)

⁽¹⁾ Corner radius tolerance (+/-)

⁽²⁾ Thread pitch minimum (mm)

⁽³⁾ Threads per inch maximum

For tools, see pages: E-GEHIR / E-GHIR (326) • GEAIR/L (325) • GEHIMR/L (323) • GEHIMR/L-SC (323) • GEHIR/L (324) • GEHIR/L-SC (324) • GEHSR (356) • GEHSR/L-SL (356)

ISCAR THREAD

CUTGRIP

GEPI-WT

Precision Ground Double-Ended Threading Inserts with a 55° Partial Profile and a Chipformer for 11.5 mm Bore Diameter

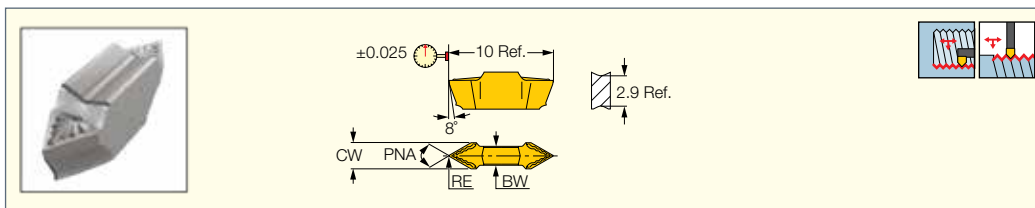

Designation	Dimensions							Tough ↔ Hard	
	CW	RE	RETOL ⁽¹⁾	PNA	BW	TPIX ⁽²⁾	TPN ⁽³⁾	IC08	IC908
GEPI 2.5-WT0.05	2.50	0.05	0.030	55	1.80	54.00	0.470	●	●

• Toolholder seat needs to be modified according to insert profile to ensure clearance • Pitch max 0.167xD, TPI min D/6.0

⁽¹⁾ Corner radius tolerance (+/-)

⁽²⁾ Threads per inch maximum

⁽³⁾ Thread pitch minimum (mm)

For tools, see pages: E-GEHIR / E-GHIR (326) • GEAIR/L (325) • GEHIMR/L (323) • GEHIMR/L-SC (323) • GEHIR/L (324) • GEHIR/L-SC (324) • GEHSR (356) • GEHSR/L-SL (356)

CUTGRIP

GHIR/L (W=1.9-6.4)

Internal Grooving and Turning Bars

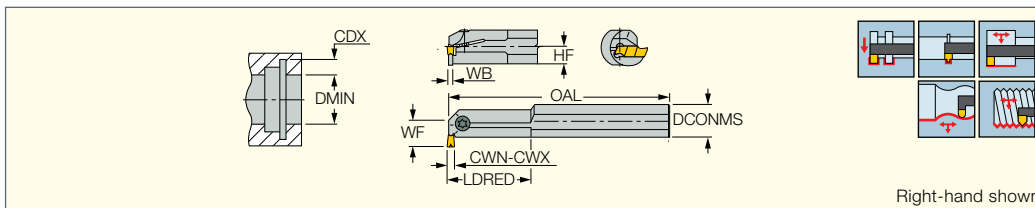

Right-hand shown

Designation	CWN ⁽¹⁾	CWX ⁽²⁾	DCONMS	DMIN	CDX	OAL	LDRED	WF	HF	WB		
GHIR/L 20-3	1.90	3.50	20.00	20.00	4.50	160.00	16.0	14.50	9.0	1.60	SR 76-1021	T-20/5
GHIR/L 20-20-3	2.00	3.50	20.00	20.00	4.50	200.00	40.0	14.50	9.0	1.60	SR 76-1021	T-20/5
GHIR/L 20-4	3.00	4.80	20.00	20.00	4.50	160.00	25.0	14.50	9.0	2.60	SR 76-1021	T-20/5
GHIR/L 20-20-4	3.00	4.80	20.00	20.00	4.50	200.00	40.0	14.50	9.0	2.60	SR 76-1021	T-20/5
GHIR/L 25-25-4	2.50	4.00	25.00	25.00	5.00	200.00	50.0	17.50	11.5	2.10	SR 76-1022	T-20/5
GHIR/L 32-4	2.50	4.00	32.00	38.00	5.00	250.00	-	21.30	14.5	2.10	SR 76-1021	T-20/5
GHIR/L 25-5	3.20	5.30	25.00	26.00	6.00	160.00	25.0	18.50	11.5	2.80	SR 76-1022	T-20/5
GHIR/L 25-25-6	4.00	6.40	25.00	25.00	5.00	200.00	50.0	17.50	11.5	3.60	SR 76-1022	T-20/5
GHIR/L 32-6	4.00	6.40	32.00	39.00	6.50	250.00	-	22.80	14.5	3.60	SR 76-1022	T-20/5
GHIR/L 40-6	4.00	6.40	40.00	49.00	8.00	300.00	-	28.30	18.0	3.60	SR 76-1022	T-20/5

• When using TIPI inserts, toolholder seat needs to be modified according to insert profile to ensure clearance. • For user guide, see pages 380-395

⁽¹⁾ Minimum cutting width

⁽²⁾ Maximum cutting width

For inserts, see pages: GIFL (336) • GIFL-E (333) • GIFL-E (full radius) (333) • GIMIY (332) • GINI-E (334) • GIPI (335) • GIPI (full radius W<M) (335) • GIPI (full radius) (336) • GIPI (W<M) (334) • GIPI-E (333) • GIPI-RX/LX (336) • TIPI-MT (337) • TIPI-WT (337)

CUTGRIP

GHIR/L-C (W=4-6.4)

Grooving and Turning Bars with Internal Coolant Holes

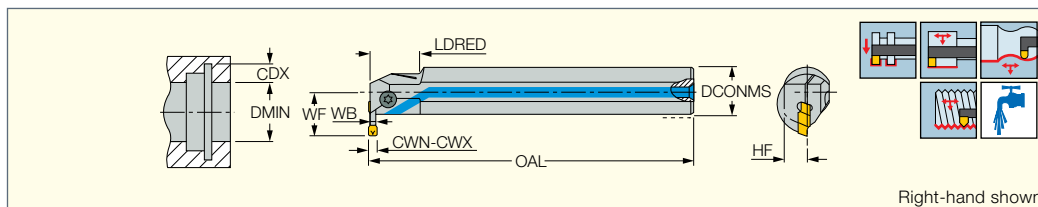

Right-hand shown

Designation	DCONMS	CWN ⁽¹⁾	CWX ⁽²⁾	DMIN	CDX	HF	OAL	LDRED	WF	WB	Inlet			
GHIR/L 25C-510	25.00	4.00	5.30	32.00	10.00	11.5	160.00	25.0	22.50	3.50	R1/8	SR 76-1022	T-20/5	PL 25
GHIR/L 32C-610	32.00	4.80	6.40	43.00	10.00	14.5	200.00	-	26.20	4.40	R1/8	SR 76-1022	T-20/5	PL 32
GHIR/L 40C-612	40.00	4.80	6.40	53.00	12.00	18.0	250.00	-	32.20	4.40	R1/8	SR 76-1022	T-20/5	PL 40

• When using TIPI inserts, toolholder seat needs to be modified according to insert profile to ensure clearance. • For user guide, see pages 380-395

⁽¹⁾ Minimum cutting width

⁽²⁾ Maximum cutting width

For inserts, see pages: GIF1 (336) • GIF1-E (333) • GIF1-E (full radius) (333) • GIMIY (332) • GINI-E (334) • GIPI (335) • GIPI (full radius) (336) • GIPI-E (333) • TIPI-MT (337)

CUTGRIP

GHIR/L-SC (W=2-4.8)

Solid Carbide Bars with Internal Coolant Holes

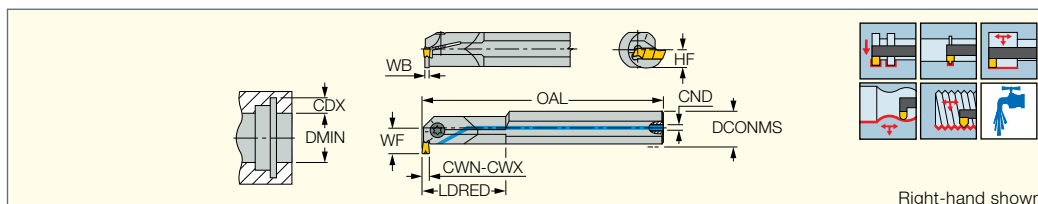

Right-hand shown

Designation	CWN ⁽¹⁾	CWX ⁽²⁾	DCONMS	DMIN	CDX	OAL	LDRED	WF	HF	CND	WB			
GHIR/L 20SC-3	2.00	3.50	20.00	20.00	4.50	200.00	60.0	14.50	9.0	8.5	1.60	SR 76-1021	T-20/5	PL 20
GHIR/L 20SC-4	3.00	4.80	20.00	20.00	4.50	200.00	60.0	14.50	9.0	8.5	2.60	SR 76-1021	T-20/5	PL 20

• Tool head is made of steel. • When using TIPI inserts, toolholder seat needs to be modified according to insert profile to ensure clearance.

• For user guide, see pages 380-395

⁽¹⁾ Minimum cutting width

⁽²⁾ Maximum cutting width

For inserts, see pages: GIF1 (336) • GIF1-E (333) • GIF1-E (full radius) (333) • GIMIY (332) • GINI-E (334) • GIPI (335) • GIPI (full radius W<M) (335) • GIPI (full radius) (336)

• GIPI-E (333) • GIPI-RX/LX (336) • TIPI-MT (337) • TIPI-WT (337)

CUTGRIP

GHIUR/L

Undercutting and Turning Boring Bars

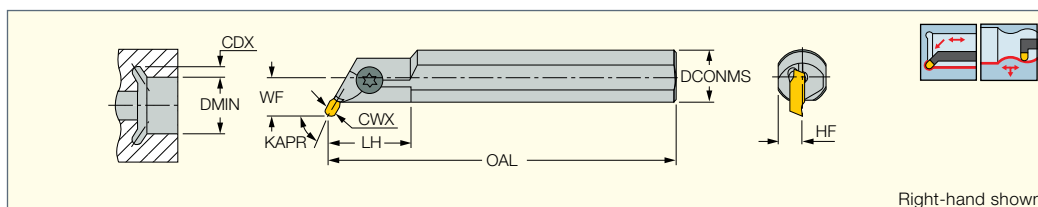

Right-hand shown

Designation	CWX ⁽¹⁾	DCONMS	DMIN	CDX	OAL	LH	WF	HF	KAPR			
GHIUR/L 20U	4.80	20.00	20.00	2.50	160.00	40.0	12.50	9.0	45.0	SR 76-1021	T-20/5	
GHIUR/L 20-20-5	4.80	20.00	20.00	3.00	200.00	51.0	13.00	9.0	60.0	SR 76-1021	T-20/5	
GHIUR/L 25U	6.40	25.00	25.00	3.00	160.00	50.0	15.50	11.5	45.0	SR 76-1022	T-20/5	
GHIUR/L 25-25-6	6.40	25.00	25.00	3.50	200.00	60.0	16.00	11.5	60.0	SR 76-1022	T-20/5	

⁽¹⁾ Maximum cutting width

For inserts, see pages: GIPI-UR/UL (337)

CUTGRIP

GHAIR/L-GI

Bars with Coolant Holes for Internal Grooving and Turning Adapters

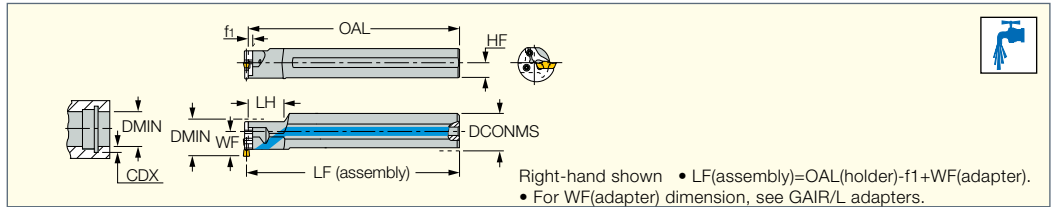

Designation	DCONMS	LH	OAL	WF	HF	f ₁	Adapter				
GHAIR/L 25-32	25.00	25.0	200.00	19.70	11.5	3.0	GAIR/L 32..	SR 16-236 P	T-15/5	PL 25	
GHAIR/L 32-32	32.00	32.0	200.00	23.20	14.5	3.0	GAIR/L 32..	SR 16-236 P	T-15/5	PL 32	
GHAIR/L 32-40	32.00	40.0	200.00	24.00	14.5	3.0	GAIR/L 40..	SR 16-212	T-20/5	PL 32	SR 14-519

• For DMIN & CDX refer to GAIR/L adapters
For tools, see pages: GAIR/L (331)

CUTGRIP

GAIR/L

Internal Grooving and Turning Adapters

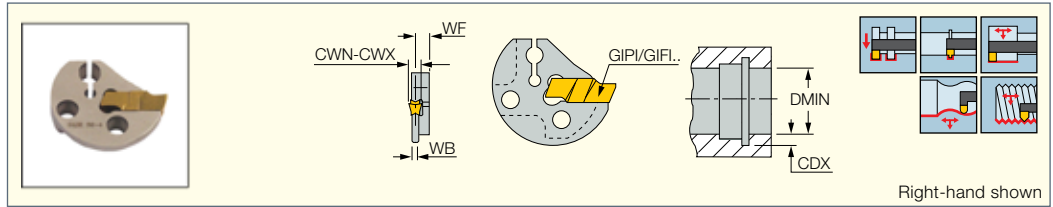

Designation	DMIN	CWN ⁽¹⁾	CWX ⁽²⁾	CDX	WF	WB
GAIR/L 32-2	32.00	1.50	2.10	3.00	3.80	1.20
GAIR/L 32-3	32.00	2.10	3.00	3.00	4.10	1.80
GAIR/L 32-4	32.00	3.00	4.50	5.00	4.50	2.50
GAIR/L 32-5	32.00	4.50	6.40	5.00	5.20	4.00
GAIR/L 40-2	40.00	1.50	2.10	3.00	3.80	1.20
GAIR/L 40-3	40.00	2.10	3.00	4.00	4.10	1.80
GAIR/L 40-4	40.00	3.00	4.50	7.00	4.50	2.50
GAIR/L 40-5	40.00	4.50	6.40	7.00	5.20	4.00

• When using TIPI inserts, toolholder seat needs to be modified according to insert profile to ensure clearance • For user guide, see pages 380-395

⁽¹⁾ Minimum cutting width

⁽²⁾ Maximum cutting width

For inserts, see pages: GIMIY (332) • GIPI-E (333) • GIFI-E (333) • GIFI-E (full radius) (333) • GINI-E (334) • GIPI (W<M) (334) • GIPI (335) • GIPI (full radius W<M) (335) • GIPI (full radius) (336) • GIFI (336) • GIPI-RX/LX (336) • TIPI-MT (337) • TIPI-WT (337)

For holders, see pages: GHAIR/L-GI (331)

CUTGRIP

GHIC-50

Boring Bars for Internal Grooving and Turning Blades DMIN=50 mm

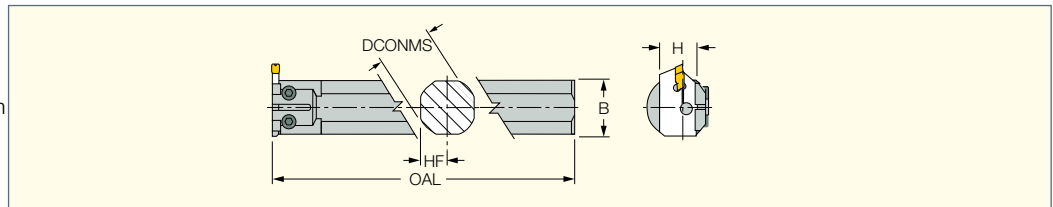

Designation	H	DCONMS	OAL	HF	B		
GHIC 32-50	26.0	32.00	220.00	14.5	29.0	SR M5X16 DIN912	HW 4.0
GHIC 40-50	26.0	40.00	260.00	18.0	36.0	SR M5X16 DIN912	HW 4.0

• For both right and left hand applications 380-395

For tools, see pages: CGIN 26 (332)

CUTGRIP

CGIN 26

Internal Grooving and Turning
Blades for GHIC...-50 Bars

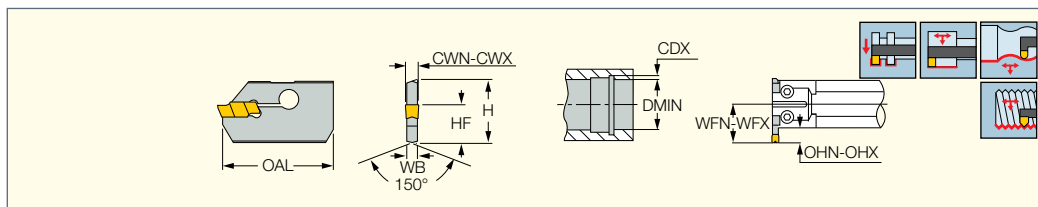

Designation	CWN ⁽¹⁾	CWX ⁽²⁾	WB	WFN ⁽³⁾	WFX ⁽⁴⁾	OHN ⁽⁵⁾	OHX ⁽⁶⁾	HF	OAL	H	DMIN
CGIN 26K-3	2.80	4.00	2.40	28.0	33.0	10.0	15.0	15.8	45.00	26.0	50.00
CGIN 26K-4	3.60	4.50	3.20	28.0	33.0	10.0	15.0	15.8	45.00	26.0	50.00
CGIN 26K-5	4.40	6.40	4.00	28.0	33.0	10.0	15.0	15.8	45.00	26.0	54.00
CGIN 26A-3	2.80	4.00	2.40	32.5	37.5	14.5	19.5	15.8	49.50	26.0	54.00
CGIN 26A-4	3.60	4.50	3.20	32.5	37.5	14.5	19.5	15.8	49.50	26.0	54.00
CGIN 26A-5	4.40	6.40	4.00	32.5	37.5	14.5	19.5	15.8	49.50	26.0	54.00

• WFN-WFX and OHN-OHX are the blade's extension range • Grooving depth (CDX) varies in conformance with blade's overhang (OHN-OHX) and depends on the bore diameter(D). For grooving capacity, see chart below • When using TIPI inserts toolholder seat needs to be modified according to insert profile to ensure clearance

• For user guide, see pages 380-395

- (1) Minimum cutting width
- (2) Maximum cutting width
- (3) Adjustable extension
- (4) Adjustable extension
- (5) Minimum overhang for adjustable extension
- (6) Maximum overhang for adjustable extension

For inserts, see pages: GIF1 (336) • GIF1-E (333) • GIF1-E (full radius) (333) • GIMIY (332) • GINI-E (334) • GIPI (335) • GIPI (full radius) (336) • GIPI-E (333) • TIPI-MT (337)
For holders, see pages: GHIC-50 (331)

Internal Grooving Capacity for CGIN Blades

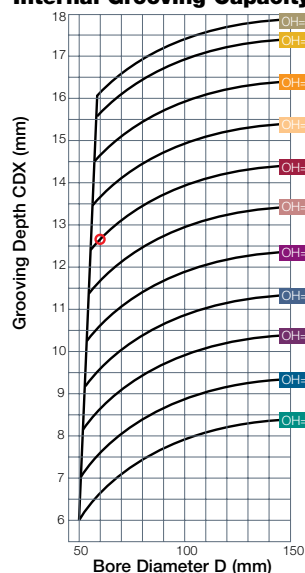

Example:

For grooving depth CDX=12.7 mm and grooving width=4 mm in bore øD=60, use blade CGIN 26A-4 and adjust overhang to OH=16 mm.

CUTGRIP

GIMIY

Utility Single-Ended Inserts for Internal Grooving and Turning

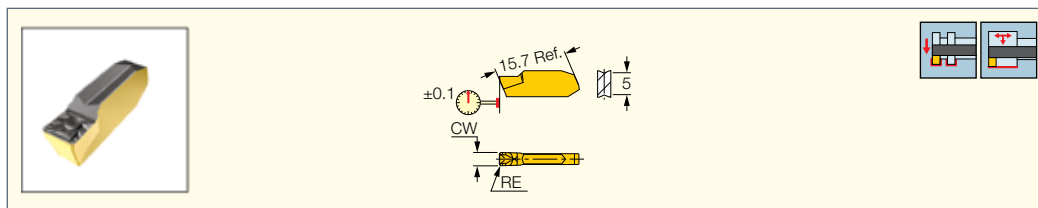

Designation	Dimensions				Tough ↔ Hard			Recommended Machining Data		
	CW	RE	CWTOL ⁽¹⁾	RETOL ⁽²⁾	IC830	IC08	IC808	a _p (mm)	f turn (mm/rev)	f groove (mm/rev)
GIMIY 304	3.00	0.40	0.02	0.050	●	●	●	0.50-1.50	0.10-0.14	0.05-0.08
GIMIY 404	4.00	0.40	0.02	0.050	●	●	●	0.50-2.00	0.13-0.19	0.06-0.11

• DMIN for internal applications=20 mm • For cutting speed recommendations and user guide, see pages 380-395

- (1) Cutting width tolerance (+/-)
- (2) Corner radius tolerance (+/-)

For tools, see pages: CGIN 26 (332) • E-GEHIR / E-GHIR (326) • GAIR/L (331) • GHIR/L (W=1.9-6.4) (329) • GHIR/L-C (W=4-6.4) (330) • GHIR/L-SC (W=2-4.8) (330)

CUTGRIP

GIPI-E

Precision Double-Ended Inserts for Internal Grooving and Turning

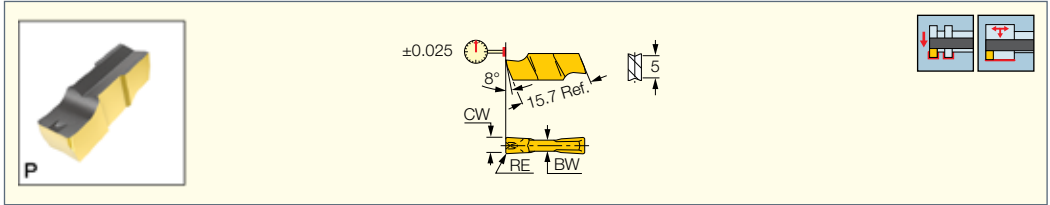

Designation	Dimensions						Tough ↔ Hard						Recommended Machining Data		
	CW	RE	CWTOL ⁽¹⁾	RETOL ⁽²⁾	BW	CDX	IC830	IC8250	IC808	IC908	IC20	IC20N	a _p (mm)	f turn (mm/rev)	f groove (mm/rev)
GIPI 3.00E-0.40	3.00	0.40	0.02	0.030	2.40	15.50	●	●	●	●	●	●	0.50-1.50	0.14-0.18	0.06-0.12
GIPI 4.00E-0.40	4.00	0.40	0.02	0.030	3.20	15.50	●	●	●	●	●	●	0.50-2.00	0.15-0.21	0.08-0.15
GIPI 5.00E-0.50	5.00	0.50	0.02	0.050	4.00	15.50	●	●	●	●	●	●	0.70-3.10	0.19-0.33	0.11-0.20
GIPI 6.35E-0.55	6.35	0.55	0.02	0.050	4.80	15.50	●	●	●	●	●	●	0.70-3.10	0.23-0.30	0.13-0.21

• DMIN for internal applications = 20 mm • For cutting speed recommendations and user guide, see pages 380-395

⁽¹⁾ Cutting width tolerance (+/-)

⁽²⁾ Corner radius tolerance (+/-)

For tools, see pages: CGIN 26 (332) • E-GEHIR / E-GHIR (326) • GAIR/L (331) • GHIR/L (W=1.9-6.4) (329) • GHIR/L-C (W=4-6.4) (330) • GHIR/L-SC (W=2-4.8) (330)

CUTGRIP

GIFI-E

Precision Double-Ended Inserts for Internal Grooving and Turning

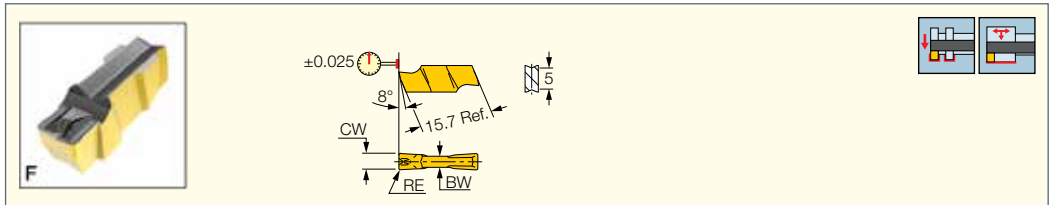

Designation	Dimensions						Tough ↔ Hard				Recommended Machining Data		
	CW	RE	CWTOL ⁽¹⁾	RETOL ⁽²⁾	BW	CDX	IC830	IC8250	IC808	IC20	a _p (mm)	f turn (mm/rev)	f groove (mm/rev)
GIFI 4.00E-0.40	4.00	0.40	0.02	0.050	3.20	15.50	●	●	●	●	0.50-2.00	0.13-0.19	0.06-0.11
GIFI 5.00E-0.50	5.00	0.50	0.02	0.050	4.00	15.50	●	●	●	●	0.60-2.50	0.16-0.24	0.08-0.14
GIFI 6.00E-0.80	6.00	0.80	0.02	0.050	4.80	15.50	●	●	●	●	1.00-3.00	0.19-0.34	0.09-0.18

• DMIN for internal applications = 20 mm • For cutting speed recommendations and user guide, see pages 380-395

⁽¹⁾ Cutting width tolerance (+/-)

⁽²⁾ Corner radius tolerance (+/-)

For tools, see pages: CGIN 26 (332) • GAIR/L (331) • GHIR/L (W=1.9-6.4) (329) • GHIR/L-C (W=4-6.4) (330) • GHIR/L-SC (W=2-4.8) (330)

CUTGRIP

GIFI-E (full radius)

Precision Double-Ended Full Radius Inserts for Internal Profiling and Grooving

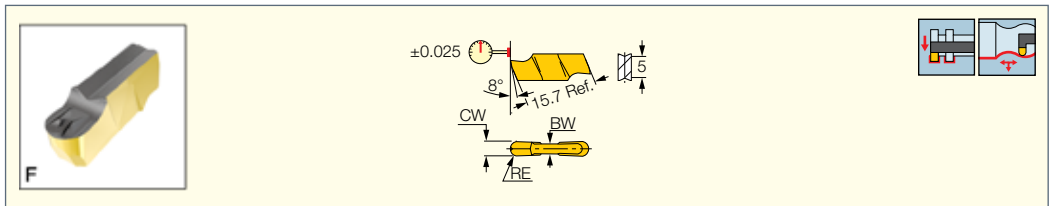

Designation	Dimensions						Tough ↔ Hard				Recommended Machining Data		
	CW	RE	CWTOL ⁽¹⁾	RETOL ⁽²⁾	BW	CDX	IC830	IC8250	IC808	IC20	a _p (mm)	f turn (mm/rev)	f groove (mm/rev)
GIFI 4.00E-2.00	4.00	2.00	0.02	0.050	3.20	14.00	●	●	●	●	0.00-2.00	0.14-0.27	0.06-0.12
GIFI 5.00E-2.50	5.00	2.50	0.02	0.050	4.00	13.50	●	●	●	●	0.00-2.50	0.18-0.34	0.08-0.15

• DMIN for internal applications = 20 mm • For cutting speed recommendations and user guide, see pages 380-395

⁽¹⁾ Cutting width tolerance (+/-)

⁽²⁾ Corner radius tolerance (+/-)

For tools, see pages: CGIN 26 (332) • GAIR/L (331) • GHIR/L (W=1.9-6.4) (329) • GHIR/L-C (W=4-6.4) (330) • GHIR/L-SC (W=2-4.8) (330)

CUTGRIP

GINI-E

Precision Double Ended Inserts, for Internal Grooving and Turning of Ductile Materials

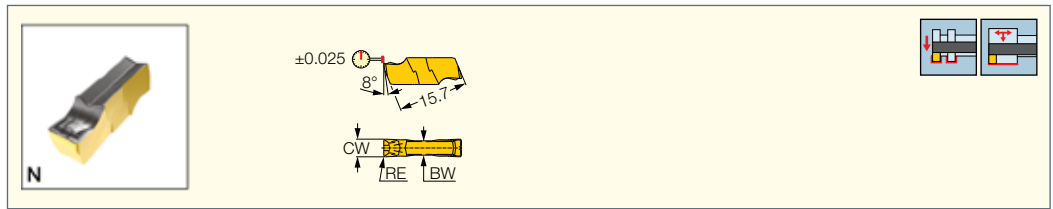

Designation	Dimensions						IC808	Recommended Machining Data		
	CW	RE	CWTOL ⁽¹⁾	RETOL ⁽²⁾	BW	CDX		a _p (mm)	f turn (mm/rev)	f groove (mm/rev)
GINI 3.00E-0.40	3.00	0.40	0.02	0.050	2.40	15.50	●	0.50-1.20	0.08-0.13	0.03-0.09
GINI 4.00E-0.40	4.00	0.40	0.02	0.050	3.20	15.50	●	0.50-1.60	0.10-0.17	0.04-0.12
GINI 5.00E-0.50	5.00	0.50	0.02	0.050	4.00	15.50	●	0.50-2.00	0.12-0.20	0.05-0.14

• DMIN for internal applications=20 mm • For cutting speed recommendations and user guide, see pages 380-395

⁽¹⁾ Cutting width tolerance (+/-)

⁽²⁾ Corner radius tolerance (+/-)

For tools, see pages: CGIN 26 (332) • E-GEHIR / E-GHIR (326) • GAIR/L (331) • GHIR/L (W=1.9-6.4) (329) • GHIR/L-C (W=4-6.4) (330) • GHIR/L-SC (W=2-4.8) (330)

CUTGRIP

GIPI (W<M)

Precision Double-Ended Inserts for Internal Grooving and Recessing

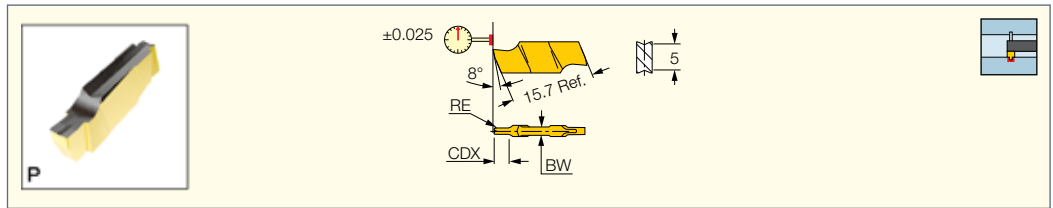

Designation	Dimensions						Tough ↔ Hard					Recommended Machining Data
	CW	RE	CWTOL ⁽¹⁾	RETOL ⁽²⁾	CDX	BW	IC830	IC808	IC908	IC20	IC806	
GIPI 1.57-0.15	1.57	0.15	0.02	0.030	2.50	2.20	●	●		●	●	0.03-0.05
GIPI 1.70-0.00	1.70	0.00	0.02	0.030	2.50	2.20	●	●		●	●	0.03-0.06
GIPI 1.78-0.10	1.78	0.10	0.02	0.030	2.50	2.20	●	●	●	●		0.03-0.06
GIPI 1.96-0.10	1.96	0.10	0.02	0.030	2.50	2.20	●	●	●	●		0.04-0.06
GIPI 1.96-0.15	1.96	0.15	0.02	0.030	2.50	2.20	●	●	●			0.04-0.06

• The tool pocket should be modified • DMIN for internal application=20 mm • For cutting speed recommendations and user guide, see pages 380-395

⁽¹⁾ Cutting width tolerance (+/-)

⁽²⁾ Corner radius tolerance (+/-)

For tools, see pages: GAIR/L (331) • GHIR/L (W=1.9-6.4) (329)

GIPI
Precision Double-Ended
Inserts for Internal Grooving
and Recessing

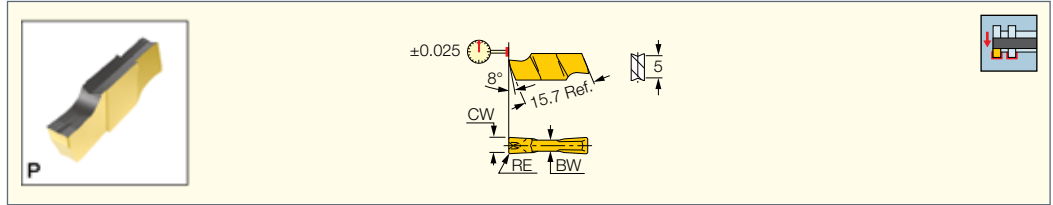

Designation	Dimensions						Tough ↔ Hard						Recommended Machining Data
	CW	RE	CWTOL ⁽¹⁾	RETOL ⁽²⁾	CDX	BW	IC830	IC8250	IC808	IC908	IC20	IC20N	
GIPI 2.22-0.10	2.22	0.10	0.02	0.030	2.50	2.20	●		●	●	●		0.04-0.07
GIPI 2.22-0.15	2.22	0.15	0.02	0.030	2.50	2.20			●	●	●		0.04-0.07
GIPI 2.30-0.20	2.30	0.20	0.02	0.030	3.00	2.20	●				●		0.05-0.08
GIPI 2.39-0.15	2.39	0.15	0.02	0.030	6.40	2.40	●		●	●			0.04-0.07
GIPI 2.50-0.20	2.50	0.20	0.02	0.030	6.00	2.40	●				●		0.05-0.09
GIPI 2.70-0.10	2.70	0.10	0.02	0.030	-	2.40	●		●	●	●	●	0.05-0.08
GIPI 2.70-0.15	2.70	0.15	0.02	0.030	-	2.40			●	●			0.05-0.08
GIPI 3.00-0.40	3.00	0.40	0.02	0.030	-	2.40					●		0.06-0.11
GIPI 3.18-0.20	3.18	0.20	0.02	0.030	-	2.40	●	●	●	●		●	0.06-0.11
GIPI 3.30-0.10	3.30	0.10	0.02	0.030	-	2.40	●	●	●	●		●	0.06-0.10
GIPI 3.96-0.20	3.96	0.20	0.02	0.030	-	3.20		●			●		0.08-0.13
GIPI 4.23-0.10	4.23	0.10	0.02	0.030	-	3.20		●			●		0.08-0.13
GIPI 4.78-0.55	4.78	0.55	0.02	0.050	-	4.00	●	●	●		●		0.08-0.15

• DMIN for internal application = 20 mm • For cutting speed recommendations and user guide, see pages 380-395

⁽¹⁾ Cutting width tolerance (+/-)

⁽²⁾ Corner radius tolerance (+/-)

For tools, see pages: CGIN 26 (332) • E-GEHIR / E-GHIR (326) • GAIR/L (331) • GHIR/L (W=1.9-6.4) (329) • GHIR/L-C (W=4-6.4) (330) • GHIR/L-SC (W=2-4.8) (330)

GIPI (full radius W<M)
Precision Double-Ended Full
Radius Inserts for Internal
Grooving and Recessing

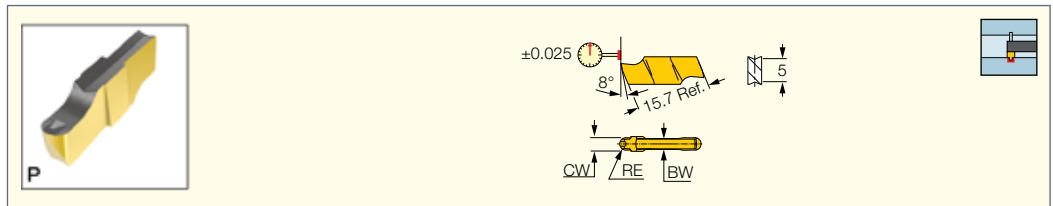

Designation	Dimensions						Tough ↔ Hard				Recommended Machining Data
	CW	RE	CWTOL ⁽¹⁾	RETOL ⁽²⁾	CDX	BW	IC830	IC808	IC908	IC20	
GIPI 2.39-1.20	2.39	1.20	0.02	0.050	6.40	2.40	●	●	●	●	0.05-0.10

• The tool pocket should be modified • DMIN for internal applications= 20 mm • For cutting speed recommendations and user guide, see pages 380-395

⁽¹⁾ Cutting width tolerance (+/-)

⁽²⁾ Corner radius tolerance (+/-)

For tools, see pages: GAIR/L (331) • GHIR/L (W=1.9-6.4) (329) • GHIR/L-SC (W=2-4.8) (330)

CUTGRIP

GIPI (full radius)

Precision Double-Ended Full Radius Inserts for Internal Grooving and Recessing

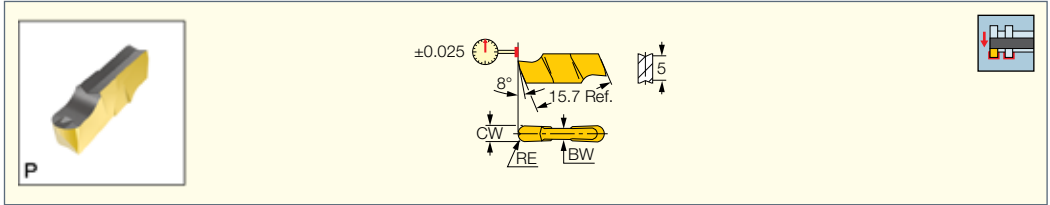

Designation	Dimensions					Tough ↔ Hard		Recommended Machining Data f groove (mm/rev)
	CW	RE	CWTOL ⁽¹⁾	RETOL ⁽²⁾	BW	IC8250	IC20	
GIPI 3.18-1.59	3.18	1.59	0.02	0.050	2.40	●	●	0.06-0.13
GIPI 3.96-1.98	3.96	1.98	0.02	0.050	3.20	●	●	0.08-0.16
GIPI 4.78-2.39	4.78	2.39	0.02	0.050	4.00	●	●	0.08-0.16
GIPI 6.35-3.18	6.35	3.18	0.02	0.050	4.80	●	●	0.11-0.21

• Dmin for internal application= 20 mm • For cutting speed recommendations and user guide, see pages 380-395

⁽¹⁾ Cutting width tolerance (+/-)

⁽²⁾ Corner radius tolerance (+/-)

For tools, see pages: CGIN 26 (332) • GAIR/L (331) • GHIR/L (W=1.9-6.4) (329) • GHIR/L-C (W=4-6.4) (330) • GHIR/L-SC (W=2-4.8) (330)

CUTGRIP

GIFI

Precision Double-Ended Inserts for Internal Grooving and Recessing

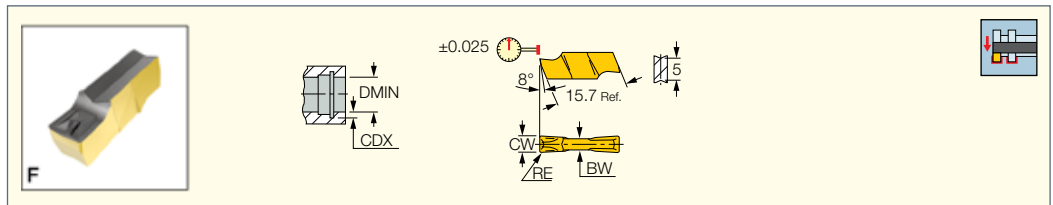

Designation	Dimensions						Tough ↔ Hard			Recommended Machining Data f groove (mm/rev)
	CW	RE	CWTOL ⁽¹⁾	RETOL ⁽²⁾	BW	CDX	IC830	IC8250	IC20	
GIFI 4.78-0.55	4.78	0.55	0.02	0.050	4.00	15.50	●	●	●	0.07-0.13
GIFI 5.28-0.20	5.28	0.20	0.02	0.030	4.00	15.50	●	●	●	0.08-0.13

• DMIN for internal applications = 20 mm • For cutting speed recommendations and user guide, see pages 380-395

⁽¹⁾ Cutting width tolerance (+/-)

⁽²⁾ Corner radius tolerance (+/-)

For tools, see pages: CGIN 26 (332) • GAIR/L (331) • GHIR/L (W=1.9-6.4) (329) • GHIR/L-C (W=4-6.4) (330) • GHIR/L-SC (W=2-4.8) (330)

CUTGRIP

GIPI-RX/LX

Precision Double-Ended Inserts for Internal Grooving Next to Shoulder

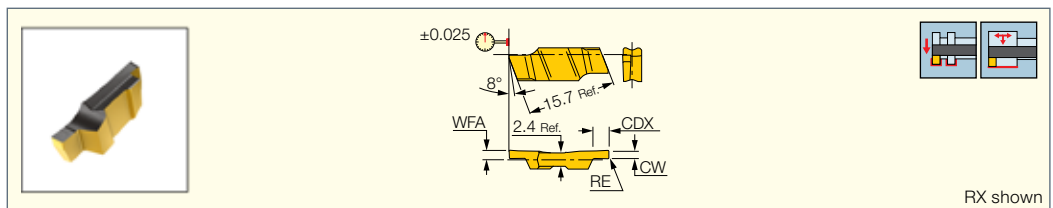

Designation	Dimensions						Tough ↔ Hard		Recommended Machining Data f groove (mm/rev)
	CW	RE	CWTOL ⁽¹⁾	RETOL ⁽²⁾	WFA	CDX	IC830	IC808	
GIPI 0.78-0.1LX	0.78	0.10	0.02	0.030	1.60	1.30		●	0.02-0.04
GIPI 1.00-0.00R/LX	1.00	0.00	0.02	0.030	1.60	2.00	●		0.02-0.04
GIPI 1.19-0.1LX	1.19	0.10	0.02	0.030	1.60	2.00		●	0.03-0.05
GIPI 1.57-0.15LX	1.57	0.15	0.02	0.030	1.70	2.80		●	0.03-0.05
GIPI 1.57-0.79LX	1.57	0.79	0.02	0.050	1.70	2.80		●	0.03-0.06
GIPI 2.00-0.10R/LX	2.00	0.10	0.02	0.030	1.70	2.70	●		0.04-0.06
GIPI 2.39-0.2LX	2.39	0.20	0.02	0.030	1.70	3.90		●	0.05-0.08
GIPI 2.39-1.19LX	2.39	1.19	0.02	0.050	1.70	3.90		●	0.05-0.10

• Tool's pocket should be modified • For grooving and recessing only • For cutting speed recommendations and user guide, see pages 380-395

⁽¹⁾ Cutting width tolerance (+/-)

⁽²⁾ Corner radius tolerance (+/-)

For tools, see pages: GAIR/L (331) • GHIR/L (W=1.9-6.4) (329) • GHIR/L-SC (W=2-4.8) (330)

CUTGRIP

GIPI-UR/UL

Precision Double-Ended Inserts for Internal Undercutting

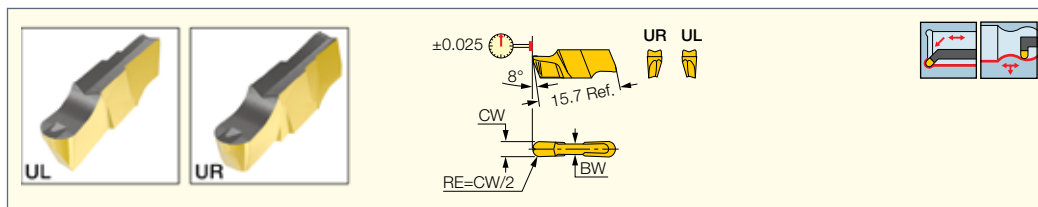

Designation	Dimensions					Tough ↔ Hard		Recommended Machining Data f groove (mm/rev)
	CW	RE	CWTOL ⁽¹⁾	RETOL ⁽²⁾	BW	IC8250	IC20	
GIPI 3.00-1.5UR/L	3.00	1.50	0.02	0.050	2.40	●	●	0.05-0.15
GIPI 4.00-2.0UR/L	4.00	2.00	0.02	0.050	3.20	●	●	0.05-0.15

• Tool's pocket should be modified • For cutting speed recommendations and user guide, see pages 380-395

⁽¹⁾ Cutting width tolerance (+/-)

⁽²⁾ Corner radius tolerance (+/-)

For tools, see pages: GHIUR/L (330)

ISCARTHREAD

CUTGRIP

TIPI-MT

Precision Ground Double-Ended Internal Threading Inserts with 60° Partial Profile and Chipformer for 20mm Min. Bore Dia.

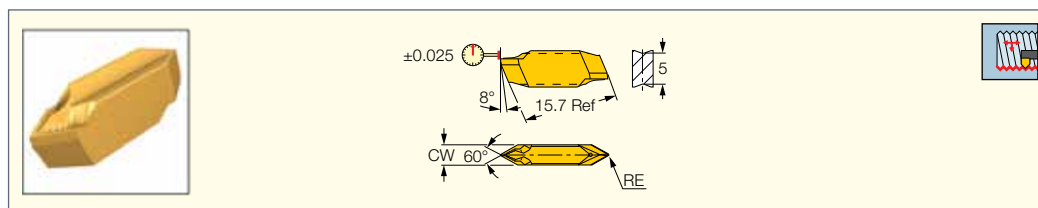

Designation	Dimensions					Tough ↔ Hard	
	CW	RE	RETOL ⁽¹⁾	TPN ⁽²⁾	TPIX ⁽³⁾	IC08	IC908
TIPI 3.4MT-0.10	3.40	0.10	0.030	1.800	14.00	●	●
TIPI 5.4MT-0.20	5.40	0.20	0.030	3.190	8.00	●	●

• Toolholder seat needs to be modified according to insert profile to ensure clearance. • Pitch max 0.205xD, TPI min D/4.8 • D=Diameter of thread (pitch max<=CW)

• TIPI inserts are 1.6 mm longer than GIPI in the same pocket

⁽¹⁾ Corner radius tolerance (+/-)

⁽²⁾ Thread pitch minimum (mm)

⁽³⁾ Threads per inch maximum

For tools, see pages: CGIN 26 (332) • GAIR/L (331) • GHIR/L (W=1.9-6.4) (329) • GHIR/L-C (W=4-6.4) (330) • GHIR/L-SC (W=2-4.8) (330)

ISCARTHREAD

CUTGRIP

TIPI-WT

Double-Ended Internal Threading Inserts with a 55° Partial Profile and a Chipformer for 20 mm Min. Bore Diameter

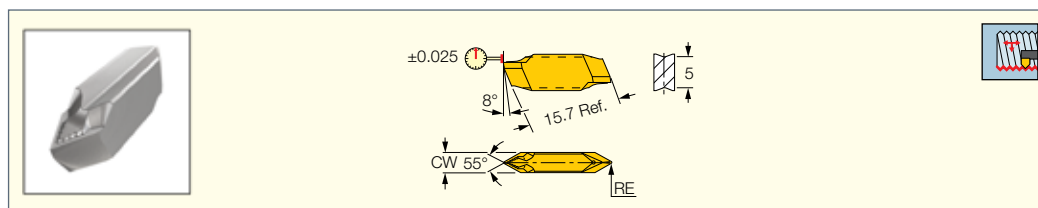

Designation	Dimensions					Tough ↔ Hard	
	CW	RE	RETOL ⁽¹⁾	TPN ⁽²⁾	TPIX ⁽³⁾	IC08	IC908
TIPI 3.4WT-0.10	3.40	0.10	0.030	0.950	27.00	●	●
TIPI 5.4WT-0.20	5.40	0.20	0.030	1.670	15.00	●	●

• Toolholder seat needs to be modified according to insert profile to ensure clearance • Pitch max 0.187xD, TPI min D/5.25 D=Diameter of thread (pitch max<=CW)

• For detailed cutting data, see pages 380-395

⁽¹⁾ Corner radius tolerance (+/-)

⁽²⁾ Thread pitch minimum (mm)

⁽³⁾ Threads per inch maximum

For tools, see pages: GAIR/L (331) • GHIR/L (W=1.9-6.4) (329) • GHIR/L-SC (W=2-4.8) (330)

TOP-GRIP

TGIR/L-C

Grooving and Turning Bars with Coolant Holes Carrying TOP-GRIP Utility Inserts

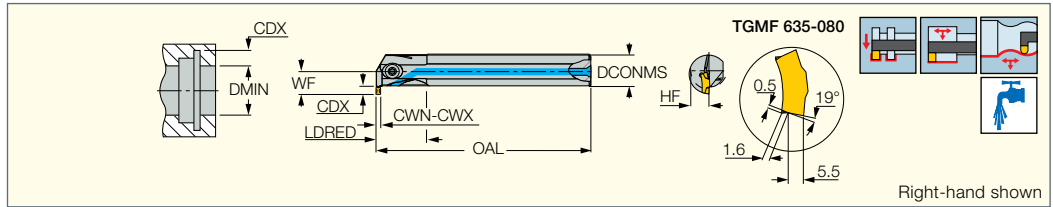

Designation	DCONMS	CWN ⁽¹⁾	CWX ⁽²⁾	DMIN	CDX ⁽³⁾	HF	OAL	LDRED	WF	Inlet	Insert
TGIR/L 16C-3	16.00	3.00	3.00	20.50	5.50	7.5	150.00	25.0	12.00	M6	TGMF 3
TGIR/L 20C-3	20.00	3.00	3.00	25.00	5.50	9.0	180.00	32.0	14.20	M6	TGMF 3
TGIR/L 25C-3	25.00	3.00	3.00	32.00	8.00	11.5	200.00	40.0	18.80	R1/8	TGMF 3
TGIR/L 25C-4	25.00	4.00	5.00	32.50	8.50	11.5	200.00	40.0	19.50	R1/8	TGMF 4, TGMF/P 5
TGIR/L 32C-4	32.00	4.00	5.00	42.00	11.00	14.5	220.00	50.0	25.50	R1/8	TGMF 4, TGMF/P 5
TGIR/L 32C-6	32.00	6.00	6.35	57.00 ⁽⁴⁾	17.50	14.5	220.00	50.0	29.00	R1/8	TGMF 6
TGIR/L 40C-6	40.00	6.00	6.35	57.00 ⁽⁴⁾	17.50	18.0	300.00	60.0	35.20	R1/8	TGMF 6

• For user guide, see pages 380-395

⁽¹⁾ Minimum cutting width

⁽²⁾ Maximum cutting width

⁽³⁾ Cutting depth maximum

⁽⁴⁾ For Dmin 47 mm, modify insert according to sketch

For inserts, see pages: TGMA (258) • TGMF (full radius) (257) • TGMF/P (257)

Spare Parts

Designation				
TGIR/L 16C-3	SR 76-1400	T-20/5		PL 16
TGIR/L 20C-3	SR 76-1400	T-20/5		PL 20
TGIR/L 25C-3	SR M5X16 DIN912		HW 4.0	PL 25
TGIR/L 25C-4	SR M5X16 DIN912		HW 4.0	PL 25
TGIR/L 32C-4	SR M6X20 DIN912		HW 5.0	PL 32
TGIR/L 32C-6	SR M6X20 DIN912		HW 5.0	PL 32
TGIR/L 40C-6	SR M6X25 DIN912		HW 5.0	PL 40

TOP-GRIP

TGHN 26-M

Internal Grooving and Turning Blades for GHIC...-70 Bars

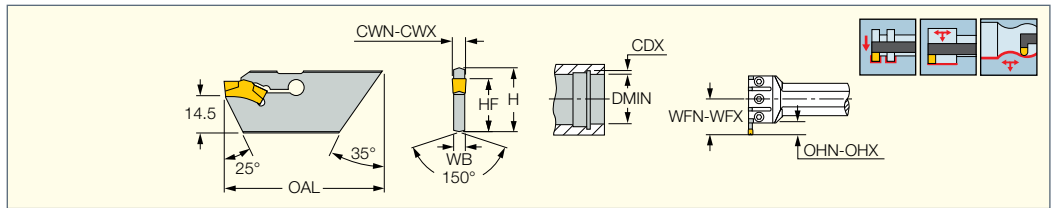

Designation	CWN ⁽¹⁾	CWX ⁽²⁾	WB	WFN ⁽³⁾	WFX ⁽⁴⁾	OHN ⁽⁵⁾	OHX ⁽⁶⁾	DMIN	HF	OAL	H
TGHN 26-3M	3.00	3.00	2.40	40.0	41.5	13.5	15.0	70.00	21.4	63.00	26.0
TGHN 26-4M	4.00	5.00	3.20	40.0	41.5	13.5	15.0	70.00	21.4	63.00	26.0
TGHN 26-5M	5.00	5.00	4.00	40.0	46.5	13.5	20.0	70.00	21.4	63.00	26.0

• Grooving depth (CDX) varies in conformance with blade's overhang (WFN-WFX and OHN-OHX) and depends on the bore diameter (D) • TGHN 26...-M can be modified from external double-sided TGHN blades • For user guide, see pages 380-395

⁽¹⁾ Minimum cutting width

⁽²⁾ Maximum cutting width

⁽³⁾ Adjustable extension

⁽⁴⁾ Adjustable extension

⁽⁵⁾ Minimum overhang for adjustable extension

⁽⁶⁾ Maximum overhang for adjustable extension

For inserts, see pages: TGMA (258) • TGMF (full radius) (257) • TGMF/P (257)

For holders, see pages: GHIC-70 (339)

Internal Grooving Capacity for TGHN Blades

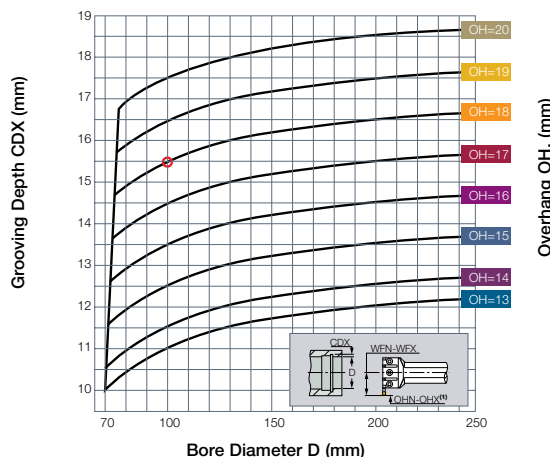

Example:

For grooving depth CDX=15.5 mm and grooving width=5 mm in bore øD=100, use blade TGHN 26-5M and adjust overhang to OH=18 mm.



TGHN 26...M

HELIIR/L

Grooving and Turning Bars with Coolant Holes for HELI-GRIP Utility Inserts

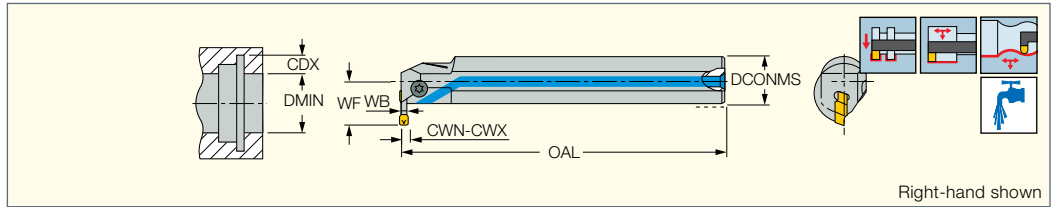

Right-hand shown

Designation	DCONMS	CWN ⁽¹⁾	CWX ⁽²⁾	DMIN	CDX ⁽³⁾	OAL	WF	Inlet	Insert ⁽⁴⁾			
HELIIR/L 20C-305	20.00	3.00	3.18	26.00	5.00	160.00	15.20	M6	GRIP 3	SR 76-1400	PL 20	T-20/5
HELIIR/L 25C-305	25.00	3.00	3.18	31.00	5.00	160.00	17.70	R1/8	GRIP 3	SR M5X16 DIN912	PL 25	HW 4.0
HELIIR/L 25C-410	25.00	4.00	4.76	43.00	10.00	160.00	22.70	R1/8	GRIP 4	SR M5X16 DIN912	PL 25	HW 4.0
HELIIR/L 25C-510	25.00	5.00	5.00	43.00	10.00	160.00	22.70	R1/8	GRIP 5	SR M5X16 DIN912	PL 25	HW 4.0
HELIIR/L 25C-610	25.00	6.00	6.35	43.00	10.00	160.00	22.70	R1/8	GRIP 6	SR M5X16 DIN912	PL 25	HW 4.0
HELIIR/L 32C-410	32.00	4.00	4.76	43.00	10.00	200.00	26.20	R1/8	GRIP 4	SR M5X16 DIN912	PL 32	HW 4.0
HELIIR/L 32C-510	32.00	5.00	5.00	43.00	10.00	200.00	26.20	R1/8	GRIP 5	SR M5X16 DIN912	PL 32	HW 4.0
HELIIR/L 32C-610	32.00	6.00	6.35	43.00	10.00	200.00	26.20	R1/8	GRIP 6	SR M5X16 DIN912	PL 32	HW 4.0
HELIIR/L 40C-412	40.00	4.00	4.76	53.00	12.00	250.00	32.20	R1/8	GRIP 4	SR M5X16 DIN912	PL 40	HW 4.0
HELIIR/L 40C-512	40.00	5.00	5.00	53.00	12.00	250.00	32.20	R1/8	GRIP 5	SR M5X16 DIN912	PL 40	HW 4.0
HELIIR/L 40C-612	40.00	6.00	6.35	53.00	12.00	250.00	32.20	R1/8	GRIP 6	SR M5X16 DIN912	PL 40	HW 4.0

• For user guide, see pages 380-395

⁽¹⁾ Minimum cutting width

⁽²⁾ Maximum cutting width

⁽³⁾ Cutting depth maximum

⁽⁴⁾ DO-GRIP DGN inserts may be used only for grooving: DGN 4.. (DMIN=51 mm), DGN 5.. (DMIN=57 mm) and DGN 6.. (DMIN=62 mm)

For inserts, see pages: GRIP (254) • GRIP (full radius) (255)

CUTGRIP

GHIR/L (W=7.0-8.3)

Internal Grooving and Turning Boring Bars

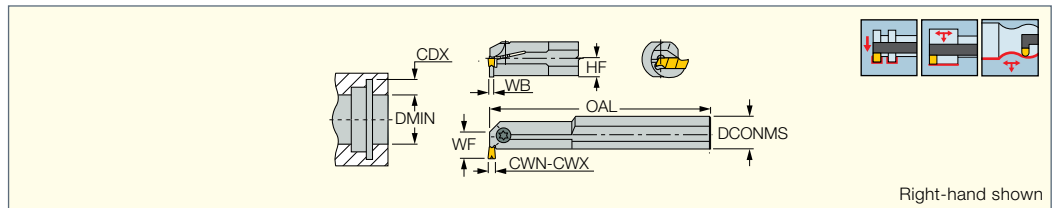

Right-hand shown

Designation	CWN ⁽¹⁾	CWX ⁽²⁾	DCONMS	DMIN	CDX	OAL	WF	HF	WB		
GHIR/L 40-815	7.00	8.30	40.00	64.00	15.00	300.00	36.00	18.0	6.00	SR M8X20DIN912	HW 6.0
GHIR/L 40-820	7.00	8.30	40.00	65.00	20.00	300.00	41.00	18.0	6.00	SR M8X20DIN912	HW 6.0

• For user guide, see pages 380-395

⁽¹⁾ Minimum cutting width

⁽²⁾ Maximum cutting width

For inserts, see pages: GDMA (284) • GDMF (271) • GDMM-CC (565) • GDMN (273) • GDMU (273) • GDMY (272) • GDMY (full radius) (274) • GDMY-F (275) • GIA-K (long pocket) (282) • GIF-E (W=8,10 full radius) (277) • GIF-E (W=8,10) (276) • GIPA/GIDA 8 (full radius) (286)

CUTGRIP

GHIC-70

Boring Bars for Internal Grooving and Turning Blades, DMIN=70 mm

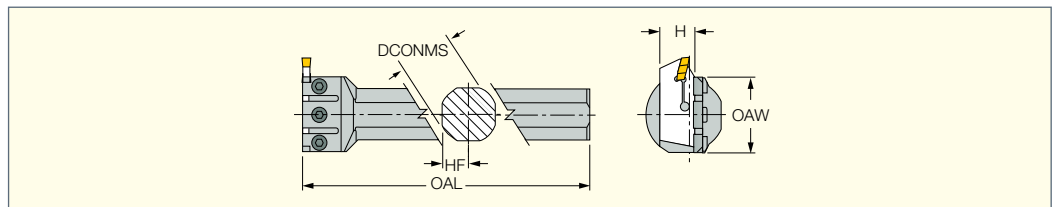

Designation	H	DCONMS	OAL	HF	OAW		
GHIC 40-70	26.0	40.00	260.00	18.0	53.0	SR M6X16 DIN912	HW 5.0
GHIC 50-70	26.0	50.00	300.00	23.0	53.0	SR M6X16 DIN912	HW 5.0

• For both right and left hand applications 380-395

For tools, see pages: CGHN 26-M (340) • TGHN 26-M (338)

CUTGRIP

GHIC-85

Boring Bars for Internal Grooving and Turning
Blades, DMIN=85 mm

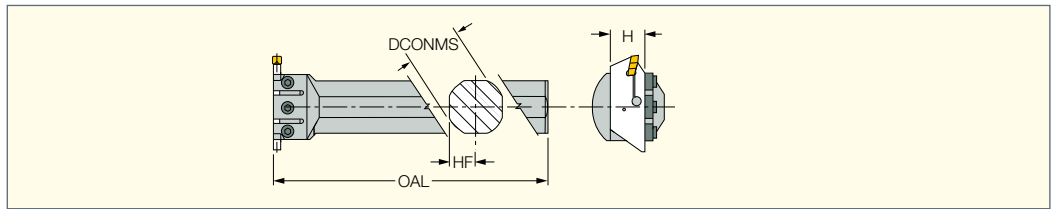

Designation	H	DCONMS	OAL	HF		
GHIC 40-85	32.0	40.00	260.00	18.0	SR M6X16 DIN912	HW 5.0
GHIC 50-85	32.0	50.00	300.00	23.0	SR M6X16 DIN912	HW 5.0

• For both right and left hand applications 380-395
For tools, see pages: CGHN 32-DGM (342) • CGHN 32-M (341)

CUTGRIP

CGHN 26-M

Internal Grooving and Turning
Blades for GHIC...-70 Bars

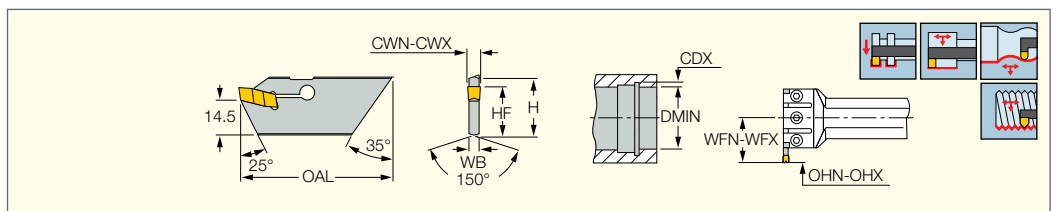

Designation	CWN ⁽¹⁾	CWX ⁽²⁾	WB	DMIN	WFN ⁽³⁾	OHN ⁽⁴⁾	WFX ⁽⁵⁾	OHX ⁽⁶⁾	HF	OAL	H
CGHN 26-3M	2.80	4.00	2.40	70.00	40.0	13.5	46.5	20.0	21.4	63.00	26.0
CGHN 26-4M	3.60	4.50	3.20	70.00	40.0	13.5	46.5	20.0	21.4	63.00	26.0
CGHN 26-5M	4.40	6.40	4.00	70.00	40.0	13.5	46.5	20.0	21.4	63.00	26.0

• Grooving depth (CDX) varies in conformance with blade's overhang (WFN-WFX and OHN-OHX) and depends on the bore diameter (D) • CGHN 26...-M can be modified from external double-sided CGHN blades • When TIP inserts are used the seat needs to be modified to ensure clearance • For user guide, see pages 380-395

- (1) Minimum cutting width
- (2) Maximum cutting width
- (3) Adjustable extension
- (4) Minimum overhang for adjustable extension
- (5) Adjustable extension
- (6) Maximum overhang for adjustable extension

For inserts, see pages: GIMF (271) • GIMY (272) • GIMN (272) • GIMY (full radius) (273) • GIMY-F (274) • GIF-E (W=4-6) (275) • GIF-E (W=4-6 full radius) (277) • GIP-E (276) • GIP-E (full radius) (278) • GIP (280) • GIP (full radius) (280) • GIF (281) • GIF (full radius) (282) • GIA-K (W=3-6) (282) • GITM (283) • GITM (full radius) (283) • GIPY (284) • GIPA (full radius W=3-6) (285) • GIPA (W=3-6) (284) • GIM-C (473) • GIM-J (473) • GIM-J-RA/LA (474) • GIM-UT (475) • GIM-UT-RA/LA (475) • GIM-W (474) • GIM-W-RA/LA (475) • GIMT (271) • GIPM-A46 / GIP-1250 (358) • TIP-MT (290) • TIP-WT (290)
For holders, see pages: GHIC-70 (339)

Internal Grooving Capacity for CGHN 26 Blades

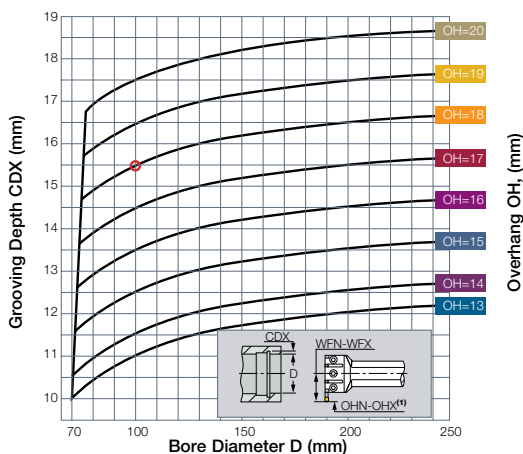

Example:

For grooving depth CDX=15.5 mm and grooving width=5 mm in bore øD=100, use blade CGHN 26-5M and adjust overhang to OH=18 mm.



CGHN 26-...M

CGHN 32-M

Internal Grooving and Turning
Blades for GHIC...-85 Bars

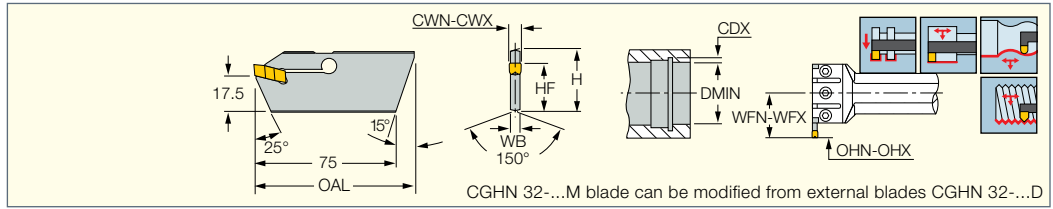

Designation	CWN ⁽¹⁾	CWX ⁽²⁾	WB	WFN ⁽³⁾	WFX ⁽⁴⁾	OHN ⁽⁵⁾	OHX ⁽⁶⁾	HF	OAL	H	DMIN
CGHN 32-3M	2.80	4.00	2.40	44.0	48.0	15.0	19.0	24.8	82.00	32.0	85.00
CGHN 32-4M	3.60	5.00	3.20	44.0	50.0	15.0	21.0	24.8	82.00	32.0	85.00
CGHN 32-5M	4.40	6.40	4.00	44.0	55.0	15.0	26.0	24.8	82.00	32.0	85.00
CGHN 32-6M	5.60	6.40	5.20	44.0	55.0	15.0	26.0	24.8	82.00	32.0	85.00

• WFN-WFX and OHN-OHX are the blade's extension range • Grooving depth (CDX) varies in conformance with blade's overhang (OHN-OHX) and depends on the bore diameter(D). For grooving capacity, see graph • When using TIP inserts, the toolholder seat needs to be modified • For user guide, see pages 380-395

- (1) Minimum cutting width
- (2) Maximum cutting width
- (3) Adjustable extension
- (4) Adjustable extension
- (5) Minimum overhang for adjustable extension
- (6) Maximum overhang for adjustable extension

For inserts, see pages: GIA-K (W=3-6) (282) • GIF (281) • GIF (full radius) (282) • GIF-E (W=4-6 full radius) (277) • GIF-E (W=4-6) (275) • GIM-C (473) • GIM-J (473) • GIM-J-RA/LA (474) • GIM-UT (475) • GIM-UT-RA/LA (475) • GIM-W (474) • GIM-W-RA/LA (475) • GIMF (271) • GIMN (272) • GIMT (271) • GIMY (272) • GIMY (full radius) (273) • GIMY-F (274) • GIP (280) • GIP (full radius) (280) • GIP-E (276) • GIP-E (full radius) (278) • GIPA (full radius W=3-6) (285) • GIPA (W=3-6) (284) • GIPM-A46 / GIP-1250 (358) • GIPY (284) • GITM (283) • GITM (full radius) (283) • TIP-MT (290) • TIP-WT (290)

For holders, see pages: GHIC-85 (340)

Internal Machining Grooving Capacity for CGHN 32 Blades

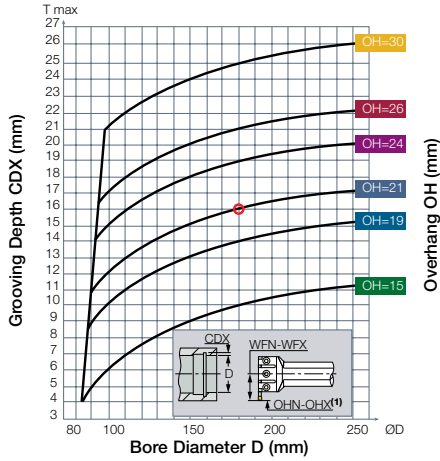

Example:

For grooving depth CDX=16 and grooving width= 4 in bore øD=180, use blade CGHN-32-4M and adjust overhang to OH=21 mm.



CGHN 32-...M/DGM

CUTGRIP

CGHN 32-DGM

Internal Grooving and Turning Blades for GHIC...-85 Bars (self-clamping)

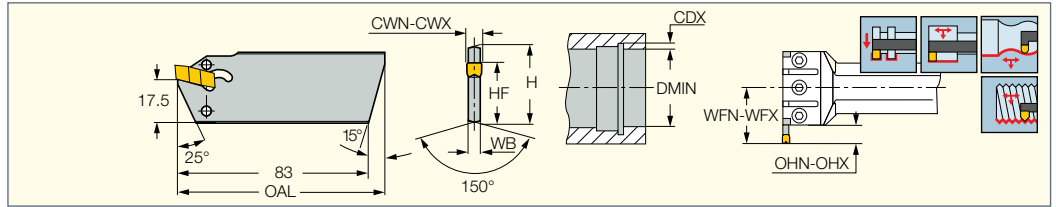

Designation	CWN ⁽¹⁾	CWX ⁽²⁾	WB	WFN ⁽³⁾	WFX ⁽⁴⁾	OHN ⁽⁵⁾	OHX ⁽⁶⁾	HF	OAL	H	DMIN	
CGHN 32-3DGM	2.80	4.00	2.40	53.0	59.0	24.0	30.0	24.8	90.00	32.0	93.00	EDG 44A*
CGHN 32-4DGM	3.50	5.00	3.20	53.0	59.0	24.0	30.0	24.8	90.00	32.0	93.00	EDG 44A*
CGHN 32-5DGM	4.40	6.40	4.00	53.0	59.0	24.0	30.0	24.8	90.00	32.0	93.00	EDG 44A*
CGHN 32-6DGM	5.60	6.40	5.20	53.0	59.0	24.0	30.0	24.8	90.00	32.0	93.00	EDG 44A*

• Grooving depth (CDX) varies in conformance with blade's overhang (WFN-WFX and OHN-OHX) and it depends on the bore diameter (D) • CGHN 32...DGM can be modified from external double-sided CGHN -DG blades • When TIP inserts are used, the seat needs to be modified to ensure clearance • For user guide, see pages 380-395

- (1) Minimum cutting width
- (2) Maximum cutting width
- (3) Adjustable extension
- (4) Adjustable extension
- (5) Minimum overhang for adjustable extension
- (6) Maximum overhang for adjustable extension

* Optional, should be ordered separately

For inserts, see pages: GIA-K (W=3-6) (282) • GIF (281) • GIF (full radius) (282) • GIF-E (W=4-6 full radius) (277) • GIF-E (W=4-6) (275) • GIM-C (473) • GIM-J (473) • GIM-J-RA/LA (474) • GIM-UT (475) • GIM-UT-RA/LA (475) • GIM-W (474) • GIM-W-RA/LA (475) • GIMF (271) • GIMN (272) • GIMT (271) • GIMY (272) • GIMY (full radius) (273) • GIMY-F (274) • GIP (280) • GIP (full radius) (280) • GIP-E (276) • GIP-E (full radius) (278) • GIPA (full radius W=3-6) (285) • GIPA (W=3-6) (284) • GIPM-A46 / GIP-1250 (358) • GIPY (284) • GITM (283) • GITM (full radius) (283) • TIP-MT (290) • TIP-WT (290)

For holders, see pages: GHIC-85 (340)

Internal Machining Grooving Capacity for CGHN 32 Blades

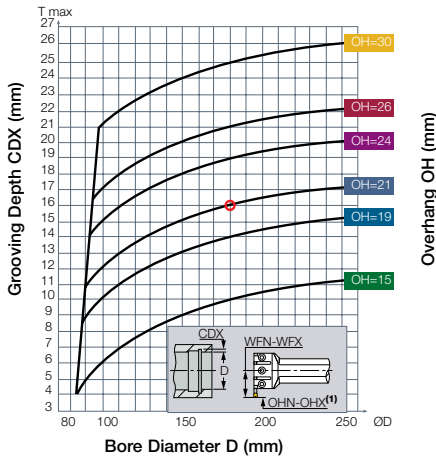

Example:

For grooving depth CDX=16 and grooving width= 4 in bore øD=180, use blade CGHN-32-4DGM and adjust overhang to OH=21 mm.



CGHN 32-...M/DGM

V-LOCK

SXCNN

External Toolholders for Specially Tailored Wide Profile Inserts

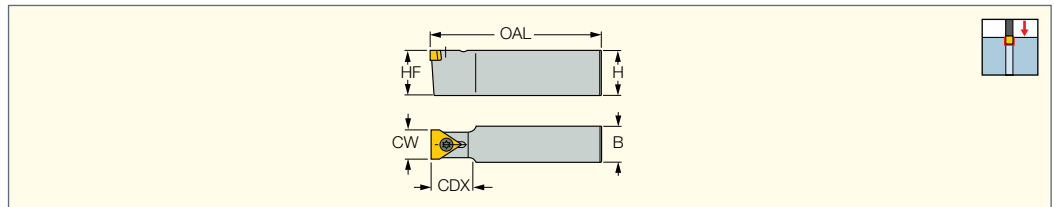

Designation	CW	CDX ⁽¹⁾	HF	H	B	OAL	Insert		
SXCNN 1212 K10-06	10.40	17.00	12.0	12.0	12.0	125.00	XNUW 10	SR 76-2067	T-15/5
SXCNN 1616 K10-06	10.40	17.00	16.0	16.0	16.0	125.00	XNUW 10	SR 76-2067	T-15/5
SXCNN 2020 P10-06	10.40	17.00	20.0	20.0	20.0	170.00	XNUW 10	SR 76-2067	T-15/5
SXCNN 2525 P10-06	10.40	17.00	25.0	25.0	25.0	170.00	XNUW 10	SR 76-2067	T-15/5
SXCNN 1212 K13-05	13.00	20.00	12.0	12.0	12.0	125.00	XNUW 13	SR 76-2068	T-20/5
SXCNN 1414 K13-05	13.00	23.00	14.0	14.0	14.0	125.00	XNUW 13	SR 76-2068	T-20/5
SXCNN 1616 K13-05	13.00	23.00	16.0	16.0	16.0	125.00	XNUW 13	SR 14-591	T-20/5
SXCNN 2020 P13-05	13.00	23.00	20.0	20.0	20.0	170.00	XNUW 13	SR 14-591	T-20/5
SXCNN 2525 P13-05	13.00	23.00	25.0	25.0	25.0	170.00	XNUW 13	SR 14-591	T-20/5
SXCNN 1212 K14-03	14.50	-	12.0	12.0	12.0	125.00	XNUW 14	SR 76-2067	T-15/5
SXCNN 1616 K14-03	14.50	17.00	16.0	16.0	16.0	125.00	XNUW 14	SR 76-2067	T-15/5
SXCNN 2020 P14-03	14.50	17.00	20.0	20.0	20.0	170.00	XNUW 14	SR 76-2067	T-15/5
SXCNN 2525 P14-03	14.50	17.00	25.0	25.0	25.0	170.00	XNUW 14	SR 76-2067	T-15/5
SXCNN 1616 K20-05	20.50	-	16.0	16.0	16.0	125.00	XNUW 20	SR 14-591	T-20/5
SXCNN 2020 P20-05	20.50	24.00	20.0	20.0	20.0	170.00	XNUW 20	SR 14-591	T-20/5
SXCNN 2525 P20-05	20.50	24.00	25.0	25.0	25.0	170.00	XNUW 20	SR 14-591	T-20/5
SXCNN 3232 P20-05	20.50	24.00	32.0	32.0	32.0	170.00	XNUW 20	SR 14-591	T-20/5
SXCNN 2525 P24-05	24.50	28.00	25.0	25.0	25.0	170.00	XNUW 24	SR 14-591	T-20/5
SXCNN 3232 P36-10	36.50	-	32.0	32.0	32.0	170.00	XNUW 36	SR 14-591	T-20/5

• Toolholder seat needs to be modified according to insert profile to ensure clearance

⁽¹⁾ Cutting depth maximum

For inserts, see pages: XNUW (344)

V-LOCK

SXCIR

Internal Toolholders for Specially Tailored Profile Inserts

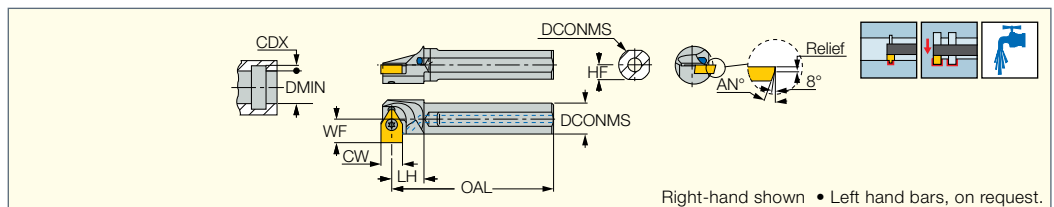

Designation	CW	DCONMS	OAL	LH	WF	DMIN	CDX ⁽²⁾	HF	AN ⁽³⁾	Relief ⁽⁴⁾			
SXCIR 16-10 ⁽¹⁾	10.40	16.00	125.00	20.0	11.50	25.00	3.00	7.5	15.0	1.5	SR 76-2067	T-15/5	PL 16
SXCIR 20-10 ⁽¹⁾	10.40	20.00	150.00	25.0	13.00	25.00	3.00	9.0	15.0	1.5	SR 76-2067	T-15/5	PL 20
SXCIR 16-13	13.00	16.00	125.00	20.0	13.00	30.00	4.00	7.5	20.0	2.0	SR 76-2068	T-20/5	PL 16
SXCIR 20-13	13.00	20.00	150.00	25.0	14.50	30.00	4.00	9.0	20.0	2.0	SR 76-2068	T-20/5	PL 20
SXCIR 25-13	13.00	25.00	170.00	30.0	17.00	30.50	4.00	11.5	20.0	2.0	SR 76-2068	T-20/5	PL 25
SXCIR 32-13	13.00	32.00	200.00	35.0	20.00	37.00	4.00	14.5	20.0	2.0	SR 76-2068	T-20/5	PL 32
SXCIR 25-14 ⁽¹⁾	14.50	25.00	170.00	30.0	15.50	30.00	3.00	11.5	15.0	2.0	SR 76-2067	T-15/5	PL 25
SXCIR 20-20	20.50	20.00	150.00	25.0	15.00	40.00	4.00	9.0	15.0	2.5	SR 14-591	T-20/5	PL 20
SXCIR 32-20	20.50	32.00	200.00	35.0	20.50	40.00	4.00	14.5	15.0	2.5	SR 14-591	T-20/5	PL 32
SXCIR 25-24	24.50	25.00	170.00	30.0	17.50	40.00	4.00	11.5	15.0	2.5	SR 14-591	T-20/5	PL 25
SXCIR 32-24	24.50	32.00	200.00	35.0	20.50	40.00	4.00	14.5	15.0	2.5	SR 14-591	T-20/5	PL 32

⁽¹⁾ On request.

⁽²⁾ Cutting depth maximum

⁽³⁾ Blank insert reference dimensions

⁽⁴⁾ Blank insert reference dimensions

For inserts, see pages: XNUW (344)

V-LOCK

XNUW

Blank Inserts for Wide Profile Grooving

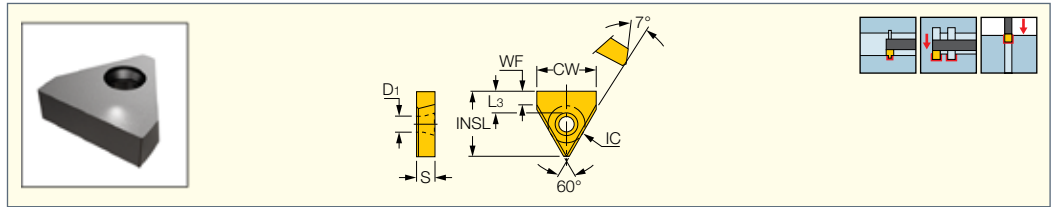

Designation	Dimensions							Tough ↔ Hard			
	CW	WF	L ₃	IC	S	D ₁	INSL	IC28	IC08	IC20	IC07
XNUW 1003-06	10.40	6.00	10.50	6.35	3.18	4.53	17.00	●	●		
XNUW 1305-05	13.00	5.00	11.40	12.70	5.35	5.50	20.60	●	●	●	
XNUW 14T3-03	14.50	3.00	3.70	9.52	3.97	4.40	14.00	●	●	●	
XNUW 2006-05	20.50	4.80	5.00	12.70	6.35	5.50	20.30	●		●	●
XNUW 2406-05	24.50	5.00	6.00	15.87	6.35	5.50	25.00	●	●	●	●
XNUW 3606-10	36.50	5.40	10.00	19.05	6.35	6.50	34.60	●	●	●	

For tools, see pages: SXCIR (343) • SXCNN (343)

FORMTOOL

FTHN

Square Shank Toolholders for FTB Profile Turning Inserts

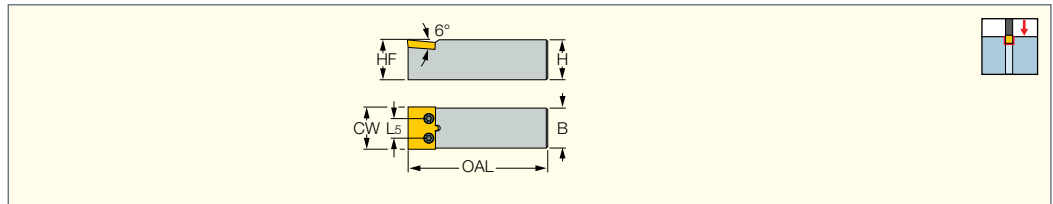

Designation	CW	H	HF	B	OAL	L ₅		
FTHN 2525M-3010	30.40	25.0	25.0	25.0	160.00	14.00	SR 14-591	T-20/5
FTHN 2525M-3510	35.40	25.0	25.0	25.0	160.00	14.00	SR 14-591	T-20/5
FTHN 3232P-3510	35.40	32.0	32.0	32.0	170.00	14.00	SR 14-591	T-20/5
FTHN 3232P-4510	45.40	32.0	32.0	32.0	170.00	18.00	SR 14-591	T-20/5
FTHN 3232P-5107	51.40	32.0	32.0	32.0	170.00	21.90	SR 14-591	T-20/5

For inserts, see pages: FTB (344)

FORMTOOL

FTB

Blank Inserts for Wide Profile Grooving

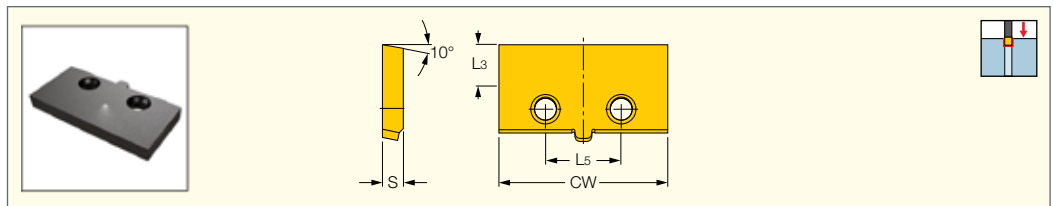

Designation	Dimensions					IC08
	CW	L ₃	S	L ₅		
FTB 3010	30.40	10.00	5.00	14.00	●	
FTB 3510	35.40	10.00	5.00	14.00	●	
FTB 4010	40.40	10.00	5.00	18.00	●	
FTB 4510	45.40	10.00	5.00	18.00	●	
FTB 5107	51.40	7.00	5.00	21.90	●	

For tools, see pages: FTBN (344)

MINIATURE



TABLE OF CONTENTS

External Tools and Inserts

SWISS-CUT	347
CUT-GRIP.....	356

Internal Boring Bars and Inserts

PICCO-CUT	359
MINCHAM.....	372
MINCUT	374
CHAMGROOVE.....	375

SCHR/L-22BF

Grooving and Turning
Tools with Back and Front
Clamping for Swiss-Type
and Automatic Machines

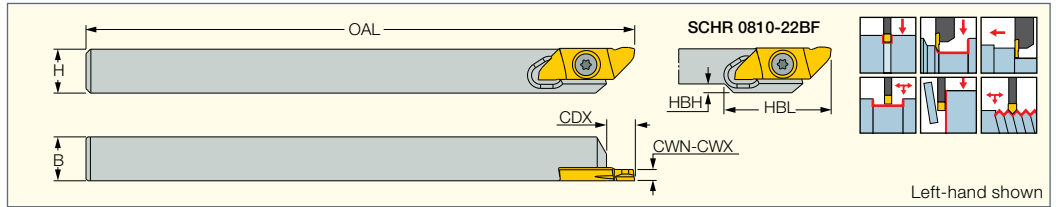

Designation	H	B	OAL	HBH	HBL	CDX ⁽¹⁾	CWN ⁽²⁾	CWX ⁽³⁾		
SCHR/L 0810-22BF	8.0	10.0	125.00	2.0	24.0	8.00	0.50	2.50	SR M4X0.7-19425	T-8/5
SCHR/L 10-22BF	10.0	10.0	125.00	-	-	8.00	0.50	2.50	SR M4X0.7-19425	T-8/5
SCHR/L 12-22BF	12.0	12.0	125.00	-	-	8.00	0.50	2.50	SR M4X0.7-19425	T-8/5
SCHR/L 16-22BF	16.0	16.0	125.00	-	-	8.00	0.50	2.50	SR M4X0.7-19425	T-8/5

- ⁽¹⁾ See insert dimensions
- ⁽²⁾ Minimum cutting width
- ⁽³⁾ Maximum cutting width

For inserts, see pages: SCIR-22-MTR-ISO (352) • SCIR/L-22-AD (351) • SCIR/L-22-AR/AL (351) • SCIR/L-22-BR/BL/BRA/BLA (349) • SCIR/L-22-ER/EL/ERA/ELA (350) • SCIR/L-22-MTR/MTL (352) • SCIR/L-22-N/R/L (348) • SCIR/L-22-NP (351) • SCIR/L-22-NX (352)

SCHR/L-22BF-JHP

Grooving and Turning Tools
with High Pressure Coolant
Channels for Swiss-Type
and Automatic Machines

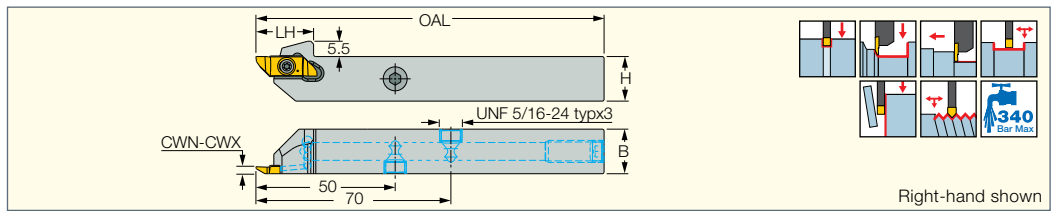

Designation	H	B	OAL	LH	CWN ⁽¹⁾	CWX ⁽²⁾	CDX ⁽³⁾				
SCHR/L 10-22BF-JHP	10.0	10.0	125.00	20.7	0.50	2.50	8.00	SR M4X0.7-19425	T-8/5	SR 5/16UNF-TL-S	HW 5/32"
SCHR/L 12-22BF-JHP	12.0	12.0	125.00	20.7	0.50	2.50	8.00	SR M4X0.7-19425	T-8/5	SR 5/16UNF TL360	HW 5/32"
SCHR/L 16-22BF-JHP	16.0	16.0	125.00	20.7	0.50	2.50	8.00	SR M4X0.7-19425	T-8/5	SR 5/16UNF TL360	HW 5/32"

• Note: Coolant ports of the left-hand tools are in the same position as those of the right-hand tools

- ⁽¹⁾ Minimum cutting width
- ⁽²⁾ Maximum cutting width
- ⁽³⁾ See insert dimensions

For inserts, see pages: SCIR-22-MTR-ISO (352) • SCIR/L-22-AD (351) • SCIR/L-22-AR/AL (351) • SCIR/L-22-BR/BL/BRA/BLA (349) • SCIR/L-22-ER/EL/ERA/ELA (350) • SCIR/L-22-MTR/MTL (352) • SCIR/L-22-N/R/L (348) • SCIR/L-22-NP (351) • SCIR/L-22-NX (352)

Flow Rate vs. Pressure

Designation	70 Bar	100 Bar	140 Bar
	Flow Rate (liters/min)	Flow Rate (liters/min)	Flow Rate (liters/min)
SCHR/L 10-22BF-JHP	1-3	2-4	3-5
SCHR/L 12-22BF-JHP	3-5	4-6	5-7
SCHR/L 16-22BF-JHP	6-8	7-9	8-10



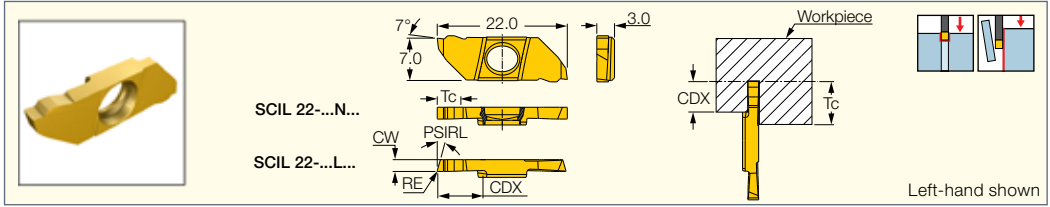

Designation	Dimensions								Tough ↔ Hard			Recommended Machining Data f groove (mm/rev)
	CW	CWTOL ⁽¹⁾	PSIRL	PSIRR	RE	RETOL ⁽²⁾	CDX	Tc	IC1008	IC07	IC1007	
SCIL 22-050N-00	0.50	0.02	-	-	0.00	0.030	1.80	5.5	●	●	●	0.02-0.04
SCIR 22-050N-00	0.50	0.02	-	-	0.00	0.030	1.80	5.5	●	●	●	0.02-0.04
SCIL 22-100N-00	1.00	0.02	-	-	0.00	0.030	4.00	5.5	●	●	●	0.03-0.05
SCIR 22-100N-00	1.00	0.02	-	-	0.00	0.030	4.00	5.5	●	●	●	0.03-0.05
SCIL 22-150N-00	1.50	0.02	-	-	0.00	0.030	5.50	8.0	●	●	●	0.03-0.07
SCIR 22-150N-00	1.50	0.02	-	-	0.00	0.030	5.50	8.0	●	●	●	0.03-0.07
SCIL 22-200N-10	2.00	0.02	-	-	0.10	0.030	7.00	8.0	●	●	●	0.03-0.09
SCIR 22-200N-10	2.00	0.02	-	-	0.10	0.030	7.00	8.0	●	●	●	0.03-0.09
SCIL 22-050L12-00	0.50	0.02	12.0	-	0.00	0.030	2.00	5.5	●			0.01-0.03
SCIR 22-050R12-00	0.50	0.02	-	12.0	0.00	0.030	2.00	5.5	●			0.01-0.03
SCIL 22-050L12-00	0.50	0.02	12.0	-	0.00	0.030	2.00	5.5	●			0.01-0.03
SCIR 22-050R12-00	0.50	0.02	-	12.0	0.00	0.030	2.00	5.5	●			0.01-0.03
SCIL 22-100L16-00	1.00	0.02	16.0	-	0.00	0.030	4.00	5.5	●			0.02-0.04
SCIR 22-100R16-00	1.00	0.02	-	16.0	0.00	0.030	4.00	5.5	●			0.02-0.04
SCIL 22-100L16-00	1.00	0.02	16.0	-	0.00	0.030	4.00	5.5	●			0.02-0.04
SCIR 22-100R16-00	1.00	0.02	-	16.0	0.00	0.030	4.00	5.5	●			0.02-0.04
SCIL 22-150L16-00	1.50	0.02	16.0	-	0.00	0.030	5.50	8.0	●			0.03-0.06
SCIR 22-150R16-00	1.50	0.02	-	16.0	0.00	0.030	5.50	8.0	●			0.03-0.06
SCIL 22-150L16-00	1.50	0.02	16.0	-	0.00	0.030	5.50	8.0	●			0.03-0.06
SCIR 22-150R16-00	1.50	0.02	-	16.0	0.00	0.030	5.50	8.0	●			0.03-0.06
SCIL 22-200L16-00	2.00	0.02	16.0	-	0.00	0.030	7.00	8.0	●			0.03-0.07
SCIR 22-200R16-00	2.00	0.02	-	16.0	0.00	0.030	7.00	8.0	●			0.03-0.07
SCIL 22-200L16-00	2.00	0.02	16.0	-	0.00	0.030	7.00	8.0	●			0.03-0.07
SCIR 22-200R16-00	2.00	0.02	-	16.0	0.00	0.030	7.00	8.0	●			0.03-0.07

• For cutting speed recommendations and user guide, see pages 380-395

⁽¹⁾ Cutting width tolerance (+/-)

⁽²⁾ Corner radius tolerance (+/-)

For tools, see pages: SCHR/L-22BF (347) • SCHR/L-22BF-JHP (347)

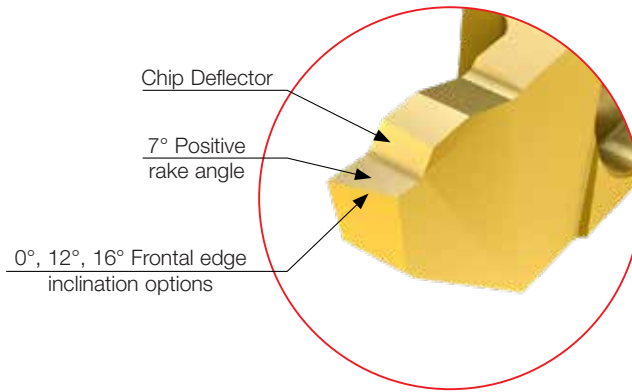
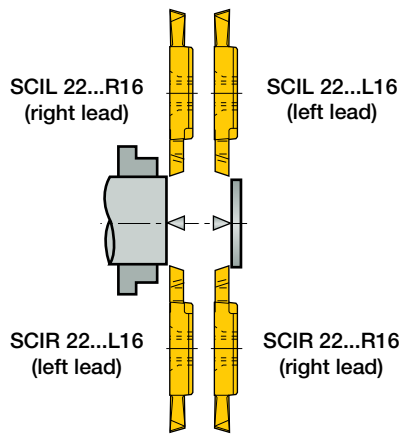

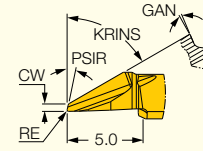
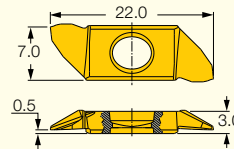

Left-hand shown

Designation	Dimensions						Tough ↔ Hard			Recommended Machining Data	
	CW	GAN	RE	PSIRL	PSIRR	KRINS ⁽¹⁾	IC1008	IC07	IC1007	a _p (mm)	f turn (mm/rev)
SCIL 22-BLA00-05K8	0.50	8.0	0.00	20.0	-	60.0		●	●	0.05-3.00	0.01-0.15
SCIL 22-BLA08-05K8	0.50	8.0	0.08	20.0	-	60.0		●	●	0.10-3.00	0.01-0.15
SCIL 22-BL00-05K7	0.50	7.0	0.00	12.0	-	60.0	●			0.05-3.00	0.01-0.15
SCIL 22-BL10-05K7	0.50	7.0	0.10	12.0	-	60.0	●			0.12-3.00	0.01-0.15
SCIR 22-BRA00-05K8	0.50	8.0	0.00	-	20.0	60.0		●	●	0.05-3.00	0.01-0.15
SCIR 22-BRA08-05K8	0.50	8.0	0.08	-	20.0	60.0		●	●	0.10-3.00	0.01-0.15
SCIR 22-BR00-05K7	0.50	7.0	0.00	-	12.0	60.0	●			0.05-3.00	0.01-0.15
SCIR 22-BR10-05K15	0.50	15.0	0.10	-	12.0	60.0	●			0.12-3.00	0.01-0.15
SCIR 22-BR10-05K7	0.50	7.0	0.10	-	12.0	60.0	●			0.12-3.00	0.01-0.15
SCIL 22-BL08-10K7	1.00	7.0	0.08	12.0	-	60.0	●			0.10-3.00	0.01-0.15
SCIR 22-BR08-10K15	1.00	15.0	0.08	-	12.0	60.0	●			0.10-3.00	0.01-0.15
SCIR 22-BR08-10K7	1.00	7.0	0.08	-	12.0	60.0	●			0.10-3.00	0.01-0.15

• For cutting speed recommendations and user guide, see pages 380-395

⁽¹⁾ Edge angle related to the wiper

For tools, see pages: SCHR/L-22BF (347) • SCHR/L-22BF-JHP (347)





SCIR/L-22-ER/EL/ERA/ELA
Back Turning Inserts for Short Chipping Materials

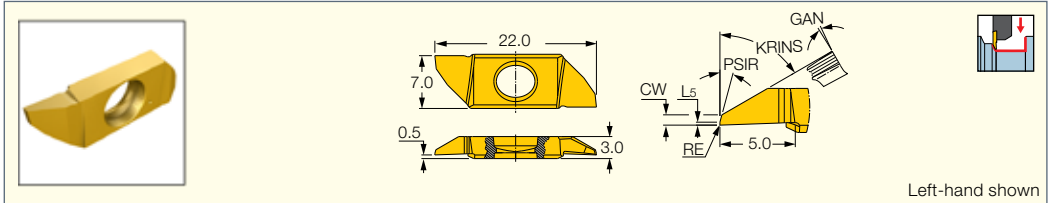

Left-hand shown

Designation	Dimensions							Tough ↔ Hard			Recommended Machining Data	
	RE	CW	L ₅	GAN	KRINS ⁽¹⁾	PSIRL	PSIRR	IC1008	IC07	IC1007	a _p (mm)	f _{turn} (mm/rev)
SCIL 22-EL00-03K0	0.00	0.30	0.20	0.0	60.0	6.0	-	●			0.05-2.50	0.01-0.15
SCIR 22-ER00-03K0	0.00	0.30	0.20	0.0	60.0	-	6.0	●			0.05-2.50	0.01-0.15
SCIL 22-EL00-07K0	0.00	0.70	0.20	0.0	60.0	15.0	-	●			0.05-2.50	0.01-0.15
SCIR 22-EL00-07K0	0.00	0.70	0.20	0.0	60.0	15.0	-	●			0.05-2.50	0.01-0.15
SCIR 22-ER00-07K0	0.00	0.70	0.20	0.0	60.0	-	15.0	●			0.05-2.50	0.01-0.15
SCIL 22-EL00-07K10	0.00	0.70	0.20	10.0	60.0	3.0	-	●			0.05-2.50	0.01-0.15
SCIR 22-ER00-07K10	0.00	0.70	0.20	10.0	60.0	-	3.0	●			0.05-2.50	0.01-0.15
SCIL 22-ELA00-08K0	0.00	0.80	0.30	0.0	70.0	3.0	-		●	●	0.05-2.50	0.01-0.15
SCIR 22-ERA00-08K0	0.00	0.80	0.30	0.0	70.0	-	3.0		●	●	0.05-2.50	0.01-0.15

• For cutting speed recommendations and user guide, see pages 380-395
⁽¹⁾ Edge angle related to the wiper

For tools, see pages: SCHR/L-22BF (347) • SCHR/L-22BF-JHP (347)

Rake Angle (GAN°) Selection Guide

	Brass	Ledloy	Steel	St. Steel	Titanium	Aluminum
0°						
8°						
15°						

For brittle workpieces and small diameters always prefer GAN=0°

Frontal Width Selection Guide

- Small diameters and brittle workpiece: small CW (less radial force)
- Large diameters: larger CW (stronger cutting edge)

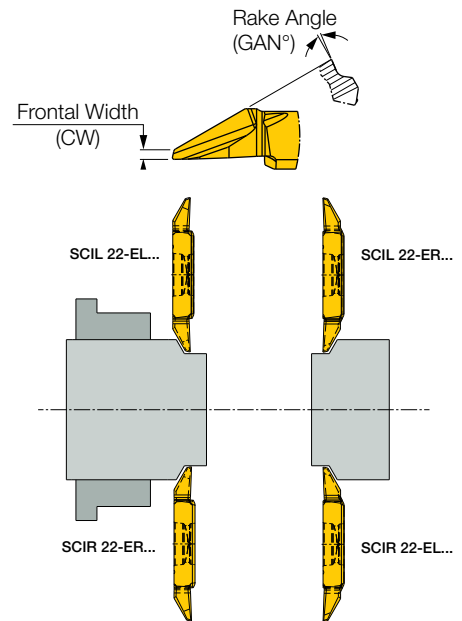

Turning Insert Selection Process

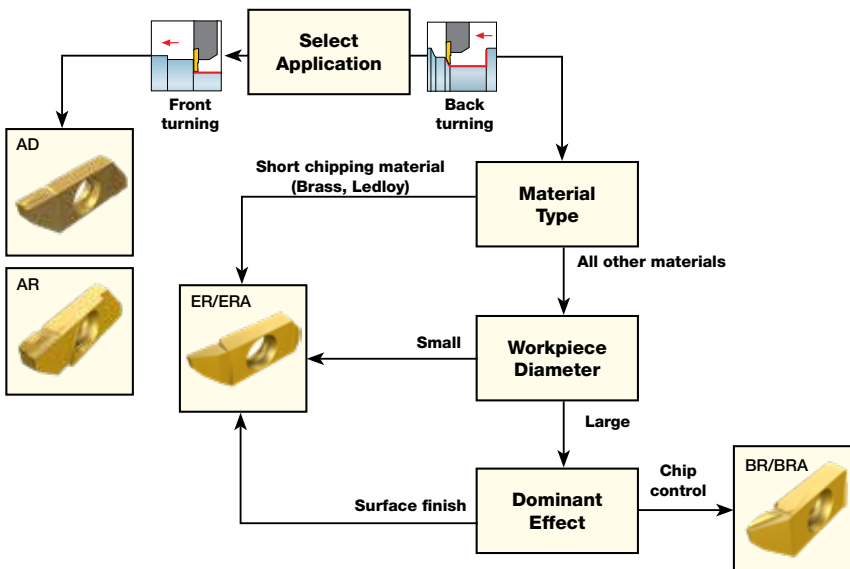

SCIR/L-22-AD
Turning Inserts with a
Frontal Relief Angle

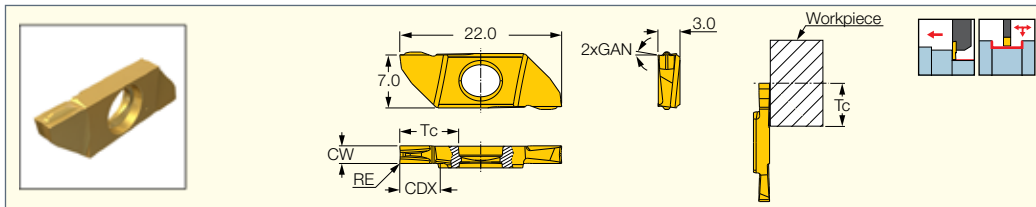

Designation	Dimensions					Tough ↔ Hard			Recommended Machining Data		
	CW	RE	Tc	GAN	CDX	IC1008	IC07	IC1007	ap (mm)	f turn (mm/rev)	f groove (mm/rev)
SCIR/L 22-AD08-24K8	2.40	0.08	8.0	8.0	5.50	●	●	●	0.12-3.80	0.01-0.15	0.01-0.06

• For cutting speed recommendations and user guide, see pages 380-395
For tools, see pages: SCHR/L-22BF (347) • SCHR/L-22BF-JHP (347)

SCIR/L-22-AR/AL
Turning Inserts with a
Frontal Relief Angle

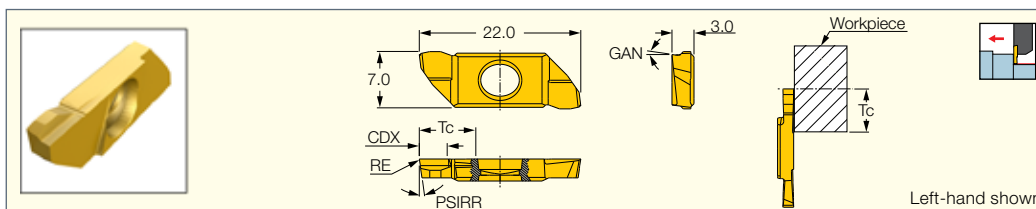

Designation	Dimensions						Tough ↔ Hard			Recommended Machining Data	
	RE	Tc	PSIRL	PSIRR	GAN	CDX ⁽¹⁾	IC1008	IC07	IC1007	ap (mm)	f turn (mm/rev)
SCIL 22-AL00-25K16	0.00	8.0	8.0	-	16.0	3.80	●	●	●	0.05-3.80	0.01-0.15
SCIR 22-AR00-25K16	0.00	8.0	-	8.0	16.0	3.80	●	●	●	0.05-3.80	0.01-0.15
SCIL 22-AL10-25K8	0.10	8.0	12.0	-	8.0	3.80	●	●	●	0.12-3.80	0.01-0.15
SCIR 22-AR10-25K8	0.10	8.0	-	12.0	8.0	3.80	●	●	●	0.12-3.80	0.01-0.15

• For cutting speed recommendations and user guide, see pages 380-395
⁽¹⁾ Cutting depth maximum

For tools, see pages: SCHR/L-22BF (347) • SCHR/L-22BF-JHP (347)

SCIR/L-22-NP
Grooving, Turning and
Parting Inserts

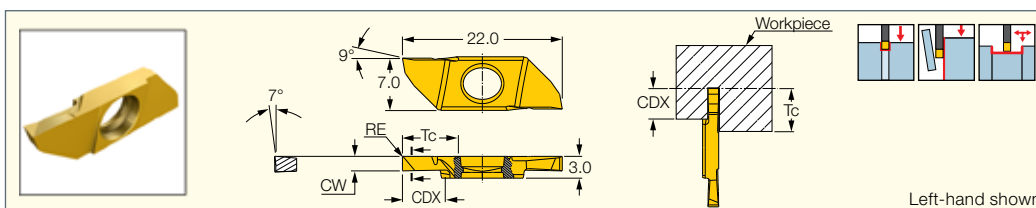

Designation	Dimensions						Tough ↔ Hard			Recommended Machining Data		
	CW	RE	CWTOL ⁽¹⁾	RETOL ⁽²⁾	CDX	Tc	IC1008	IC07	IC1007	ap (mm)	f turn (mm/rev)	f groove (mm/rev)
SCIR/L 22-080NP00	0.80	0.00	0.02	0.020	2.50	8.0	●	●	●	0.05-0.70	0.02-0.06	0.02-0.05
SCIR/L 22-100NP08	1.00	0.08	0.02	0.020	3.00	8.0	●	●	●	0.05-0.80	0.02-0.08	0.02-0.06
SCIR/L 22-150NP05	1.50	0.05	0.02	0.020	6.00	8.0	●	●	●	0.05-1.80	0.02-0.11	0.02-0.07
SCIR/L 22-200NP05	2.00	0.05	0.02	0.020	6.00	8.0	●	●	●	0.05-2.50	0.03-0.15	0.03-0.09
SCIR/L 22-250NP05	2.50	0.05	0.02	0.020	6.00	8.0	●	●	●	0.05-3.10	0.03-0.19	0.03-0.11

• For cutting speed recommendations and user guide, see pages 380-395
⁽¹⁾ Cutting width tolerance (+/-)
⁽²⁾ Corner radius tolerance (+/-)

For tools, see pages: SCHR/L-22BF (347) • SCHR/L-22BF-JHP (347)

SWISSCUT
INNOVAL LINE

SCIR/L-22-NX

Grooving and Turning
Inserts with a Chipformer

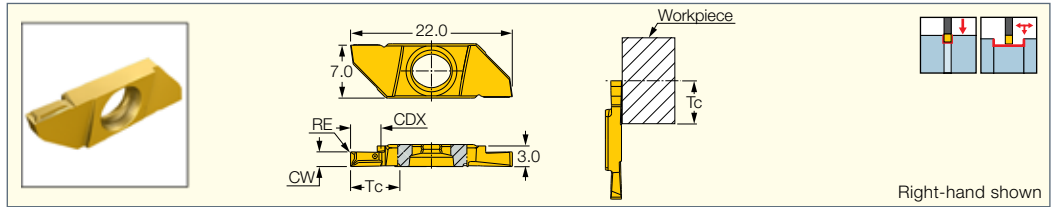

Designation	Dimensions						IC1008	Recommended Machining Data		
	CW	CWTOL ⁽¹⁾	RE	RETOL ⁽²⁾	CDX ⁽³⁾	Tc ⁽⁴⁾		a _p (mm)	f turn (mm/rev)	f groove (mm/rev)
SCIR/L 22-150NX080	1.50	0.02	0.08	0.020	4.30	6.8	●	0.05-1.80	0.02-0.11	0.02-0.07
SCIR/L 22-200NX080	2.00	0.02	0.08	0.020	4.30	6.8	●	0.05-2.50	0.03-0.15	0.03-0.09
SCIR/L 22-250NX080	2.50	0.02	0.08	0.020	4.30	6.8	●	0.05-3.10	0.03-0.19	0.03-0.11

• For cutting speed recommendations and user guide, see pages 380-395

⁽¹⁾ Cutting width tolerance (+/-)

⁽²⁾ Corner radius tolerance (+/-)

⁽³⁾ Cutting depth maximum

⁽⁴⁾ Maximum 32 mm diameter for face turning

For tools, see pages: SCHR/L-22BF (347) • SCHR/L-22BF-JHP (347)

ISCARTHREAD

SWISSCUT
INNOVAL LINE

SCIR/L-22-MTR/MTL

Threading Inserts with
a 60° Partial Profile

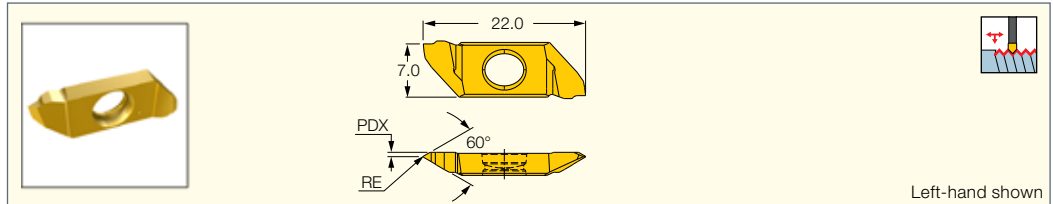

Designation	Dimensions						Tough ← Hard		
	RE	PDX	TPN ⁽¹⁾	TPX ⁽²⁾	TPIX ⁽³⁾	TPIN ⁽⁴⁾	IC1008	IC07	IC1007
SCIL 22-MTL003	0.03	0.4	0.300	0.900	83.00	28	●	●	●
SCIR 22-MTR003	0.03	0.4	0.300	0.900	83.00	28	●	●	●
SCIL 22-MTR/L007	0.07	0.5	0.700	1.100	36.00	23	●	●	●
SCIR 22-MTR/L007	0.07	0.5	0.700	1.100	36.00	23	●	●	●
SCIL 22-MTL010	0.10	0.8	0.900	1.700	28.00	15	●	●	●
SCIR 22-MTR010	0.10	0.8	0.900	1.700	28.00	15	●	●	●

• For detailed cutting data, see pages 380-395

⁽¹⁾ Thread pitch minimum (mm)

⁽²⁾ Thread pitch maximum (mm)

⁽³⁾ Threads per inch maximum

⁽⁴⁾ Threads per inch minimum

For tools, see pages: SCHR/L-22BF (347) • SCHR/L-22BF-JHP (347)

ISCARTHREAD

SWISSCUT
INNOVAL LINE

SCIR-22-MTR-ISO

Precision Ground ISO Metric
Full Profile Threading Inserts

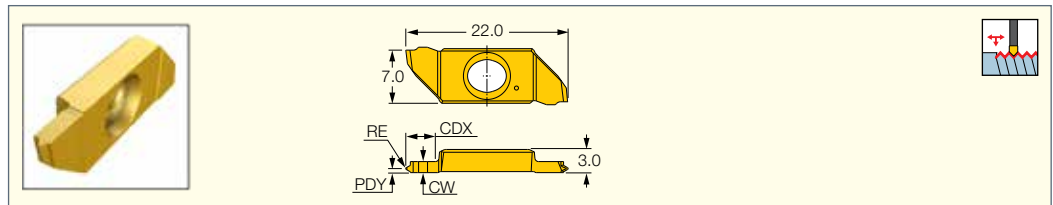

Designation	Dimensions					IC1008
	TP	CW	CDX	RE	PDY	
SCIR 22-MTR-0.3ISO	0.300	1.00	3.00	0.03	0.2	●
SCIR 22-MTR-0.4ISO	0.400	1.00	3.00	0.04	0.2	●
SCIR 22-MTR-0.5ISO	0.500	1.00	3.00	0.06	0.3	●
SCIR 22-MTR-0.75ISO	0.750	1.00	3.00	0.10	0.4	●
SCIR 22-MTR-1.0ISO	1.000	1.50	4.00	0.14	0.6	●
SCIR 22-MTR-1.5ISO	1.500	2.00	4.00	0.20	0.8	●

For tools, see pages: SCHR/L-22BF (347) • SCHR/L-22BF-JHP (347)

SCHR/L-41BF

Grooving and Turning
Tools with Back and Front
Clamping for Swiss-Type
and Automatic Machines

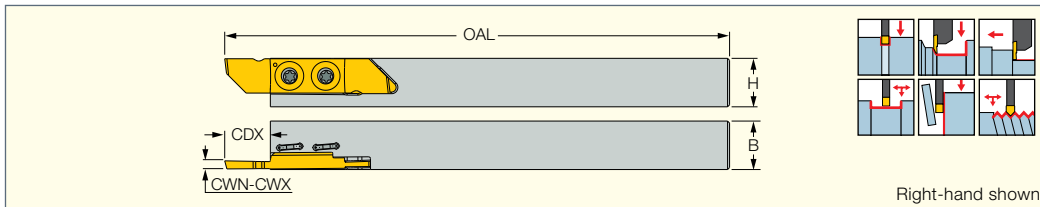

Designation	CWX ⁽¹⁾	CDX ⁽²⁾	H	B	OAL					
SCHR/L 12-41BF	3.00	11.00	12.0	12.0	125.00	SR M4.5X0.75-L7.9	BLD T15/S7	SR M2X0.4-L3.5	BLD T10/S7	SW6-SD
SCHR/L 16-41BF	3.00	11.00	16.0	16.0	125.00	SR M4.5X0.75-L7.9	BLD T15/S7	SR M2X0.4-L3.5	BLD T10/S7	SW6-SD

⁽¹⁾ Maximum cutting width

⁽²⁾ See insert data

For inserts, see pages: SCIR/L-41-AD (354) • SCIR/L-41-AR/AL (354) • SCIR/L-41-BRA/BLA (353) • SCIR/L-41-ERA/ELA (354) • SCIR/L-41-MTR/MTL (355)
• SCIR/L-41-NP (355) • SCIR/L-41-R/L (353)

SCIR/L-41-R/L

Parting Inserts

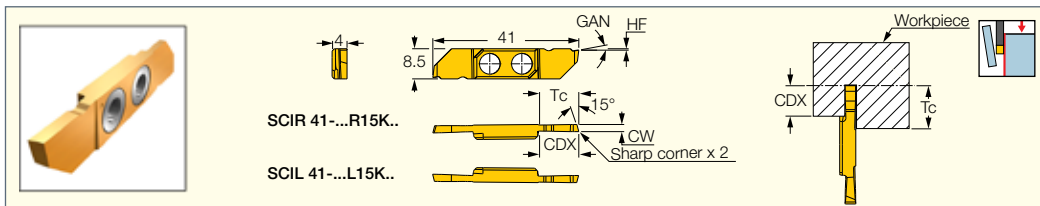

Designation	Dimensions						IC1008	Recommended Machining Data
	CW	GAN	HF ⁽¹⁾	CDX	Tc	f groove (mm/rev)		
SCIL 41-100L15K00	1.00	0.0	0.2	6.00	11.0	●	0.02-0.04	
SCIR 41-100R15K00	1.00	0.0	0.2	6.00	11.0	●	0.02-0.04	
SCIL 41-150L15K00	1.50	0.0	0.2	8.00	11.0	●	0.03-0.06	
SCIR 41-150R15K00	1.50	0.0	0.2	8.00	11.0	●	0.03-0.06	
SCIL 41-150L15K7	1.50	7.0	0.5	8.00	11.0	●	0.03-0.06	
SCIR 41-150R15K7	1.50	7.0	0.5	8.00	11.0	●	0.03-0.06	
SCIL 41-200L15K00	2.00	0.0	0.2	10.00	11.0	●	0.03-0.07	
SCIR 41-200R15K00	2.00	0.0	0.2	10.00	11.0	●	0.03-0.07	
SCIL 41-200L15K7	2.00	7.0	0.5	10.00	11.0	●	0.03-0.07	
SCIR 41-200R15K7	2.00	7.0	0.5	10.00	11.0	●	0.03-0.07	
SCIL 41-250L15K00	2.50	0.0	0.2	10.00	11.0	●	0.03-0.07	
SCIR 41-250R15K00	2.50	0.0	0.2	10.00	11.0	●	0.03-0.07	
SCIL 41-250L15K7	2.50	7.0	0.5	10.00	11.0	●	0.03-0.07	
SCIR 41-250R15K7	2.50	7.0	0.5	10.00	11.0	●	0.03-0.07	
SCIL 41-300L15K00	3.00	0.0	0.2	10.00	11.0	●	0.03-0.08	
SCIR 41-300R15K00	3.00	0.0	0.2	10.00	11.0	●	0.03-0.08	

• For cutting speed recommendations and user guide, see pages 380-395

⁽¹⁾ Cutting edge below center

For tools, see pages: SCHR/L-41BF (353)

SCIR/L-41-BRA/BLA

Back Turning Inserts

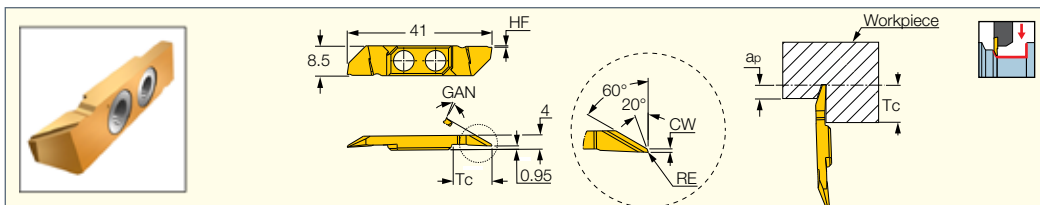

Designation	Dimensions						IC1008	Recommended Machining Data	
	CW	RE	Tc	HF ⁽¹⁾	GAN	a _p (mm)		f turn (mm/rev)	
SCIL 41-BLA08-05K8	0.50	0.08	11.0	0.5	8.0	●	0.10-4.20	0.02-0.15	
SCIR 41-BRA08-05K8	0.50	0.08	11.0	0.5	8.0	●	0.10-4.20	0.02-0.15	
SCIL 41-BLA08-10K8	1.00	0.08	11.0	0.5	8.0	●	0.10-4.20	0.02-0.15	
SCIR 41-BRA08-10K8	1.00	0.08	11.0	0.5	8.0	●	0.10-4.20	0.02-0.15	

• For cutting speed recommendations and user guide, see pages 380-395

⁽¹⁾ Cutting edge below center

For tools, see pages: SCHR/L-41BF (353)



SCIR/L-41-ERA/ELA
Back Turning Inserts for
Short Chipping Materials

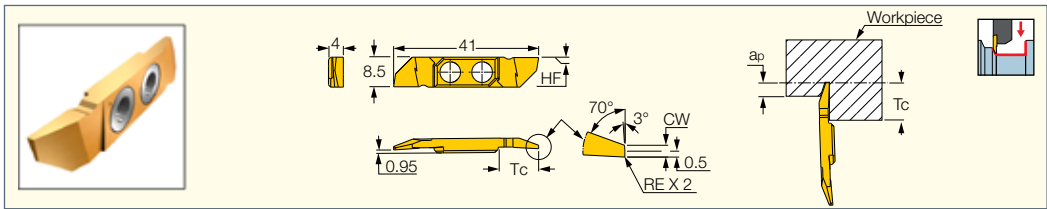

Designation	Dimensions					IC1008	Recommended Machining Data	
	CW	RE	Tc	HF ⁽¹⁾	a _p (mm)		f turn (mm/rev)	
SCIL 41-ELA00-10K0	1.00	0.00	11.0	0.2	●	0.05-5.00	0.02-0.15	
SCIR 41-ERA00-10K0	1.00	0.00	11.0	0.2	●	0.05-5.00	0.02-0.15	
SCIL 41-ELA08-10K0	1.00	0.08	11.0	0.2	●	0.10-5.00	0.02-0.15	
SCIR 41-ERA08-10K0	1.00	0.08	11.0	0.2	●	0.10-5.00	0.02-0.15	

• For cutting speed recommendations and user guide, see pages 380-395
⁽¹⁾ Cutting edge below center

For tools, see pages: SCHR/L-41BF (353)



SCIR/L-41-AD
Turning Inserts

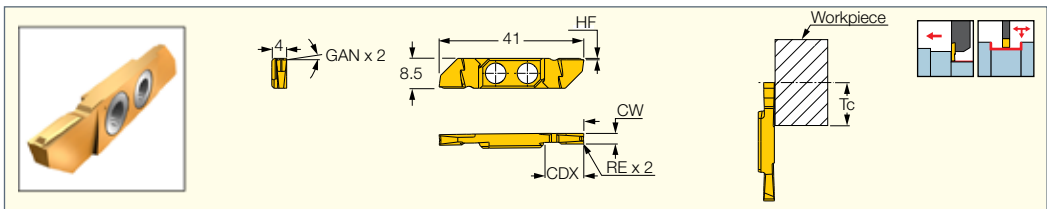

Designation	Dimensions						IC1008	Recommended Machining Data		
	CW	RE	CDX	Tc	HF ⁽¹⁾	GAN		a _p (mm)	f turn (mm/rev)	f groove (mm/rev)
SCIR/L 41-AD08-30K8	3.00	0.08	11.00	11.0	0.5	8.0	●	0.12-4.00	0.02-0.15	0.01-0.06

• For cutting speed recommendations and user guide, see pages 380-395
⁽¹⁾ Cutting edge below center

For tools, see pages: SCHR/L-41BF (353)



SCIR/L-41-AR/AL
Turning Inserts with a
Frontal Relief Angle

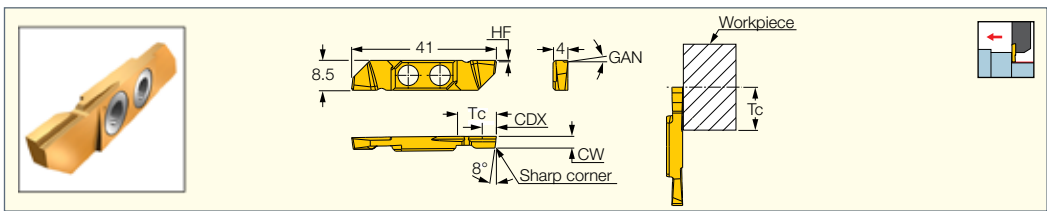

Designation	Dimensions					IC1008	Recommended Machining Data	
	CDX	CW	HF ⁽¹⁾	Tc	GAN		a _p (mm)	f turn (mm/rev)
SCIL 41-AL00-33K16	4.00	3.30	0.5	11.0	16.0	●	0.05-4.00	0.02-0.15
SCIR 41-AR00-33K16	4.00	3.30	0.5	11.0	16.0	●	0.05-4.00	0.02-0.15

• For cutting speed recommendations and user guide, see pages 380-395
⁽¹⁾ Cutting edge below center

For tools, see pages: SCHR/L-41BF (353)

SCIR/L-41-NP
Grooving, Turning and Parting Inserts

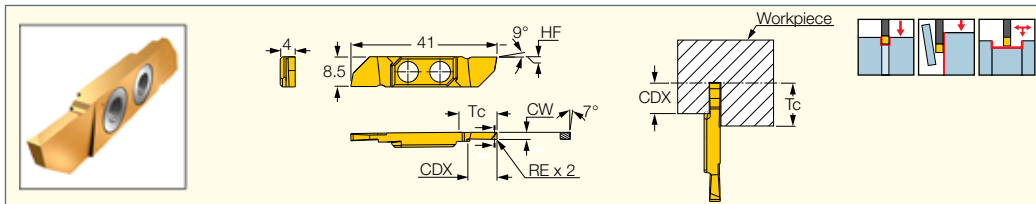

Designation	Dimensions					IC1008	Recommended Machining Data		
	CW	RE	HF ⁽¹⁾	CDX	Tc		a _p (mm)	f turn (mm/rev)	f groove (mm/rev)
SCIR/L 41-150NP08	1.50	0.08	0.2	8.00	11.0	●	0.10-1.80	0.02-0.10	0.02-0.07
SCIR/L 41-200NP08	2.00	0.08	0.2	8.00	11.0	●	0.10-2.50	0.02-0.15	0.02-0.09
SCIR/L 41-250NP08	2.50	0.08	0.2	10.00	11.0	●	0.10-3.00	0.02-0.17	0.02-0.11
SCIR/L 41-300NP08	3.00	0.08	0.2	10.00	11.0	●	0.10-4.00	0.02-0.20	0.02-0.12

• When turning to the opposite side of chipformer, maximum D.O.C. is 0.5 mm

⁽¹⁾ Cutting edge below center

For tools, see pages: SCHR/L-41BF (353)

ISCARTHREAD

SCIR/L-41-MTR/MTL
Threading Inserts with a 60° Partial Profile

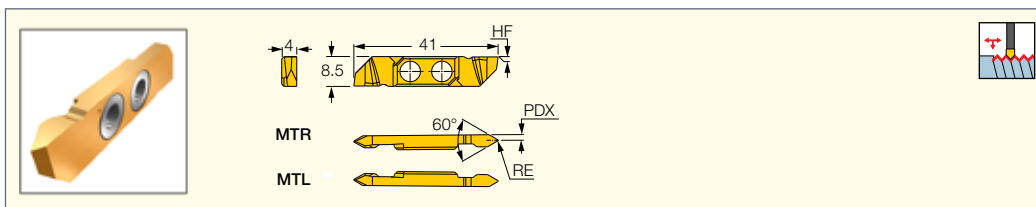

Designation	Dimensions							IC1008
	RE	PDX	TPN ⁽¹⁾	TPX ⁽²⁾	TPIN ⁽³⁾	TPIX ⁽⁴⁾	HF ⁽⁵⁾	
SCIL 41-MTL006	0.06	0.9	0.400	1.500	17.00	64.00	0.2	●
SCIR 41-MTR006	0.06	0.9	0.400	1.500	17.00	64.00	0.2	●
SCIL 41-MTL020	0.20	1.6	1.500	2.500	10.00	17.00	0.2	●
SCIR 41-MTR020	0.20	1.6	1.500	2.500	10.00	17.00	0.2	●

• For detailed cutting data, see pages 380-395

⁽¹⁾ Thread pitch minimum (mm)

⁽²⁾ Thread pitch maximum (mm)

⁽³⁾ Threads per inch minimum

⁽⁴⁾ Threads per inch maximum

⁽⁵⁾ Cutting edge below center

For tools, see pages: SCHR/L-41BF (353)



CUTGRIP

GEHSR/L-SL

External Machining Tools
with Side Clamping
Mechanism for Swiss-Type
and Automatic Machines

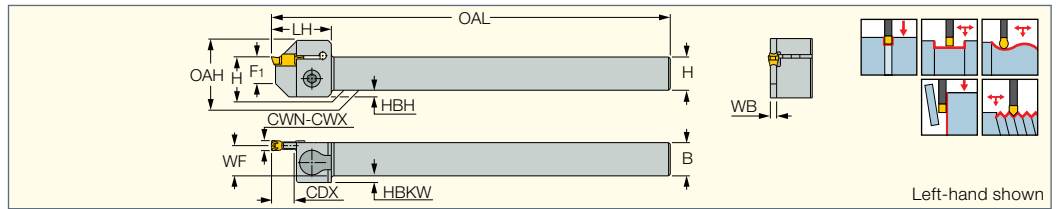

Designation	H	CWN ⁽¹⁾	CWX ⁽²⁾	CDX	B	OAL	WF	HBH	HBKW	WB	LH	F1	OAH
GEHSR/L 10-2-SL	10.0	2.20	3.20	6.80	10.0	120.00	9.10	2.0	2.00	1.80	18.0	8.0	15.0
GEHSR/L 12-2-SL	12.0	2.20	3.20	6.80	12.0	120.00	11.10	-	-	1.80	18.0	8.0	17.0
GEHSR/L 16-2-SL	16.0	2.20	3.20	6.80	16.0	120.00	15.10	-	-	1.80	18.0	8.0	21.0

• For user guide, see pages 380-395

⁽¹⁾ Minimum cutting width

⁽²⁾ Maximum cutting width

For inserts, see pages: GEMI (326) • GEMI (full radius) (326) • GEPI (327) • GEPI (full radius) (328) • GEPI-MT (329) • GEPI-WT (329)

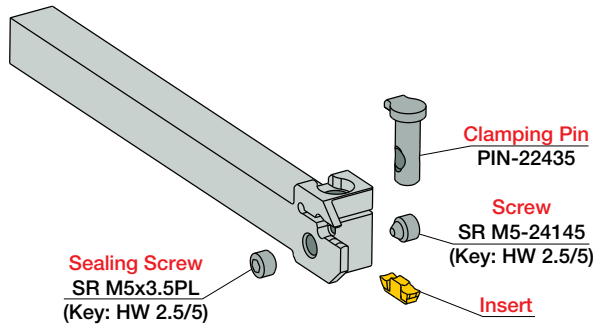

Spare Parts

Designation				
GEHSR/L-SL	PIN-22435*	SR M5-24145	HW 2.5/5	SR M5X3.5PL

* Optional, should be ordered separately

CUTGRIP

GEHSR

External Machining Holders
for Swiss-Type and
Automatic Machines

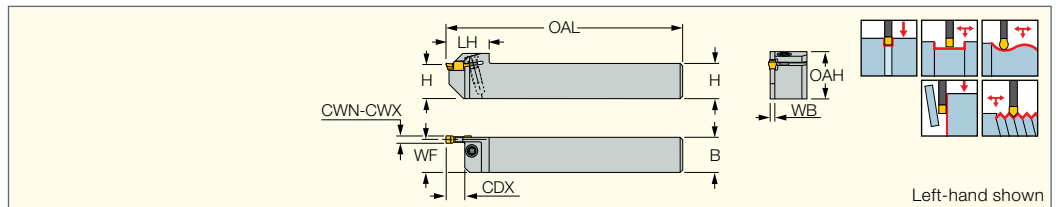

Designation	H	CWN ⁽¹⁾	CWX ⁽²⁾	CDX	B	OAL	WF	WB	LH	OAH		
GEHSR 20-2	20.0	2.20	3.20	6.80	20.0	120.00	19.10	1.80	20.0	24.0	SR 16-236 P	T-15/3
GEHSR 25-2	25.0	2.20	3.20	6.80	25.0	120.00	24.10	1.80	20.0	29.0	SR 16-236 P	T-15/3

• For user guide, see pages 380-395

⁽¹⁾ Minimum cutting width

⁽²⁾ Maximum cutting width

For inserts, see pages: GEMI (326) • GEMI (full radius) (326) • GEPI (327) • GEPI (full radius) (328) • GEPI-MT (329) • GEPI-WT (329)

CUTGRIP

PHSR/L

External Machining Holders for Swiss-Type and Automatic Machines

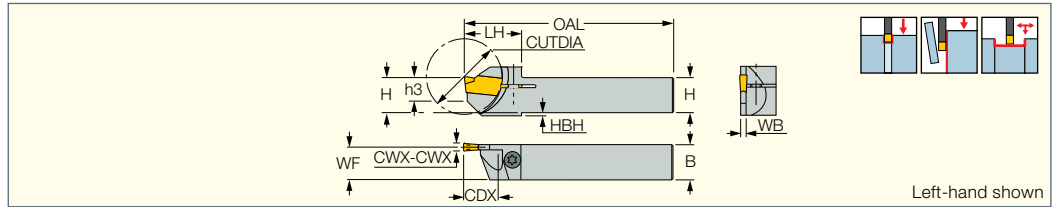

Designation	CWN ⁽¹⁾	CWX ⁽²⁾	CUTDIA ⁽³⁾	H	B	OAL	WF	h ₃	LH	HBH	WB		
PHSR/L 10-2.4	2.40	3.18	20.0	10.0	10.0	150.00	9.00	8.0	18.0	2.0	1.90	SR 16-236 P	T-15/3
PHSR/L 12-2.4	2.40	3.18	25.0	12.0	12.0	150.00	11.10	7.0	20.0	-	1.90	SR 16-236 P	T-15/3
PHSR/L 16-2.4	2.40	3.18	32.0	16.0	16.0	150.00	15.10	8.0	24.1	-	1.90	SR 16-236 P	T-15/3

• CDX=Max depth capacity, see chart below • For user guide, see pages 380-395

- ⁽¹⁾ Minimum cutting width
- ⁽²⁾ Maximum cutting width
- ⁽³⁾ Limited by part diameter

For inserts, see pages: GDMW 2.4 (294)

Grooving Depth

Grooving Depth CDX per Diameter for Width > 2.1 mm

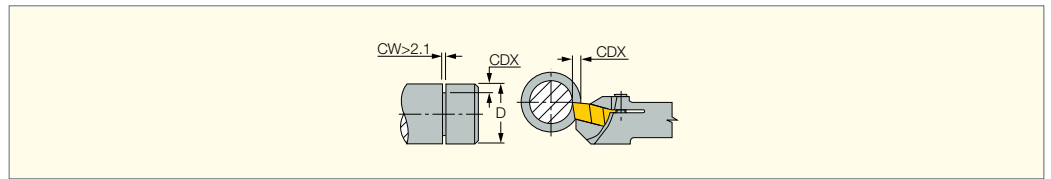

Tmax	5.0	4.5	4.0	3.5	3.0	2.5	2.3	2.0	1.7
D	10.5	10.8	11.5	12.6	14.5	17	20	25	34

Tmax is also limited by insert

CUTGRIP

GHSR/L

External Machining Holders for Swiss-Type and Automatic Machines

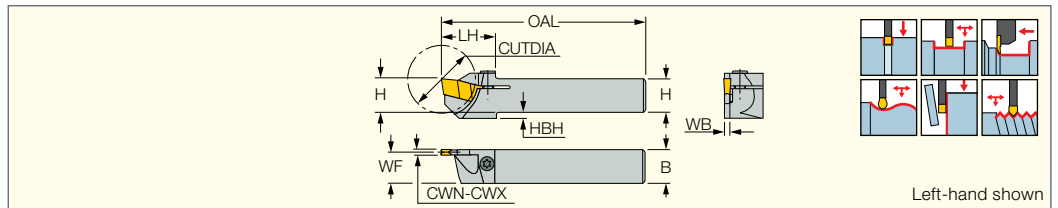

Designation	CWN ⁽¹⁾	CWX ⁽²⁾	CUTDIA ⁽³⁾	H	B	OAL	WF	LH	HBH	WB		
GHSR/L 10-2	2.20	3.15	20.0	10.0	10.0	120.00	9.10	18.0	2.0	1.80	SR 16-236 P	T-15/3
GHSR/L 12-2	2.20	3.15	25.0	12.0	12.0	120.00	11.10	20.0	2.0	1.80	SR 16-236 P	T-15/3
GHSR/L 14-2	2.20	3.15	26.0	14.0	14.0	120.00	13.10	20.0	-	1.80	SR 16-236 P	T-15/3
GHSR/L 16-2	2.20	3.15	32.0	16.0	16.0	120.00	15.10	26.0	-	1.80	SR 16-212	T-20/3

• For user guide, see pages 380-395

- ⁽¹⁾ Minimum cutting width
- ⁽²⁾ Maximum cutting width
- ⁽³⁾ For CW>2.1 mm: grooving depth depends on part diameter

For inserts, see pages: GIG (279) • GIM-J (473) • GIM-J-RA/LA (474) • GIMY (272) • GIMY (full radius) (273) • GIMY-F (274) • GIP (280) • GIP (full radius W<M) (279) • GIP (full radius) (280) • GIP-E (276) • GIP-E (full radius) (278) • GIPA (full radius W=3-6) (285) • GIPA (W=3-6) (284) • GIPM-A46 / GIP-1250 (358) • GIPY (284) • GITM (283) • GITM (full radius) (283) • TIP-MT (290) • TIP-P-BSPT (293) • TIP-P-BSW (292) • TIP-P-ISO (291) • TIP-P-NPT (292) • TIP-P-UN (291) • TIP-WT (290)

Grooving Depth

Grooving Depth Tmax per Diameter for Width > 2.1 mm

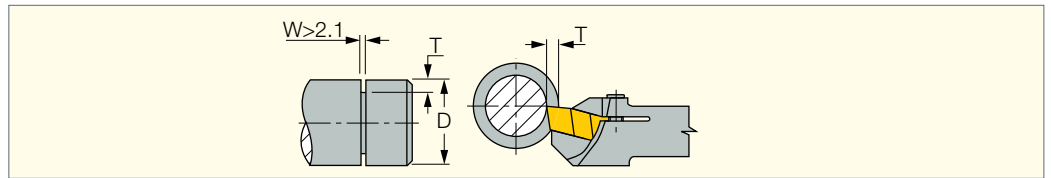

Tmax	5.0	4.5	4.0	3.5	3.0	2.5	2.3	2.0	1.7
D	10.5	10.8	11.5	12.6	14.5	17	20	25	34

Tmax is also limited by insert

CUTGRIP JETCUT

GHSR/L-JHP-SL
Grooving and Turning Side Lock Tools with Channels for High Pressure Coolant on Swiss-Type and Automatic Machines

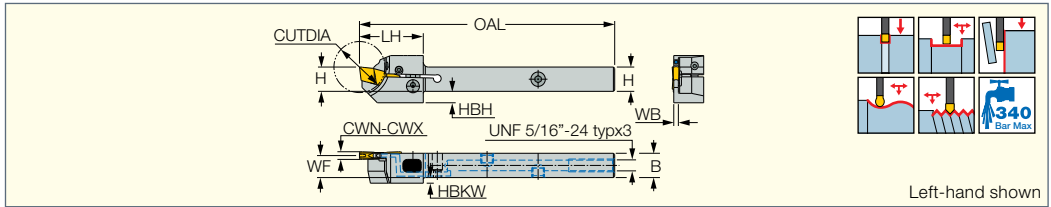

Designation	CWN ⁽¹⁾	CWX ⁽²⁾	H	B	CUTDIA	OAL	LH	WF	HBKW	WB
GHSR/L 10-2-JHP-SL	2.20	3.00	10.0	10.0	20.0	100.00	25.0	9.10	2.2	1.80
GHSR/L 12-2-JHP-SL	2.20	3.00	12.0	12.0	25.0	100.00	25.0	11.10	-	1.80
GHSR/L 16-2-JHP-SL	2.20	3.00	16.0	16.0	25.0	120.00	27.0	15.10	-	1.80
GHSR/L 12-3-JHP-SL	2.80	4.00	12.0	12.0	25.0	100.00	25.0	10.80	-	2.40
GHSR/L 16-3-JHP-SL	2.80	4.00	16.0	16.0	25.0	120.00	27.0	14.80	-	2.40

• For user guide and accessories, see pages 380-400

⁽¹⁾ Minimum cutting width

⁽²⁾ Maximum cutting width

For inserts, see pages: GIG (279) • GIM-J (473) • GIM-J-RA/LA (474) • GIMY (272) • GIMY (full radius) (273) • GIMY-F (274) • GIP (280) • GIP (full radius W<M) (279) • GIP (full radius) (280) • GIP-E (276) • GIP-E (full radius) (278) • GIPA (full radius W=3-6) (285) • GIPA (W=3-6) (284) • GIPM-A46 / GIP-1250 (358) • GIPY (284) • GITM (283) • GITM (full radius) (283) • TIP-MT (290) • TIP-P-BSPT (293) • TIP-P-BSW (292) • TIP-P-ISO (291) • TIP-P-NPT (292) • TIP-P-UN (291) • TIP-WT (290)

Flow Rate vs. Pressure

Designation	70 Bar Flow Rate (liters/min)	100 Bar Flow Rate (liters/min)	140 Bar Flow Rate (liters/min)
GHSR/L...-JHP-SL	4-6	7-9	9-11

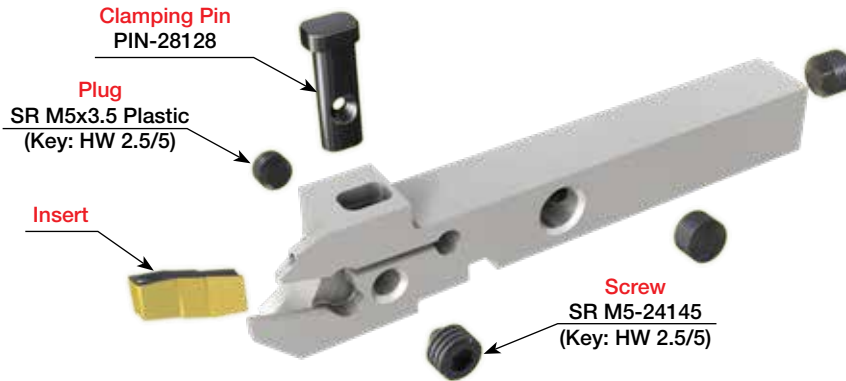

Spare Parts

Designation						
GHSR/L 10-2-JHP-SL	PIN-28128 INJ	SR M5-24145	SR M5X3.5PL	HW 2.5/5	SR 5/16XUNF-TL-S	HW 5/32"
GHSR/L 12-2-JHP-SL	PIN-28128 INJ	SR M5-24145	SR M5X3.5PL	HW 2.5/5	SR 5/16UNF TL360	HW 5/32"
GHSR/L 16-2-JHP-SL	PIN-28128 INJ	SR M5-24145	SR M5X3.5PL	HW 2.5/5	SR 5/16UNF TL360	HW 5/32"
GHSL 12-3-JHP-SL	PIN-28128 INJ	SR M5-24145	SR M5X3.5PL	HW 2.5/5	SR 5/16UNF TL360	HW 5/32"
GHSL 12-3-JHP-SL	PIN-28128 INJ	SR M5-24145	SR M5X3.5PL	HW 2.5/5	SR 5/16UNF TL360	HW 5/32"
GHSL 16-3-JHP-SL	PIN-28128 INJ	SR M5-24145	SR M5X3.5PL	HW 2.5/5	SR 5/16UNF TL360	HW 5/32"
GHSR 16-3-JHP-SL	PIN-28128 INJ	SR M5-24145	SR M5X3.5PL	HW 2.5/5	SR 5/16UNF TL360	HW 5/32"

CUTGRIP

GIPM-A46 / GIP-1250
Precision Back Turning Inserts for External Machining on Swiss-Type and Automatic Machines

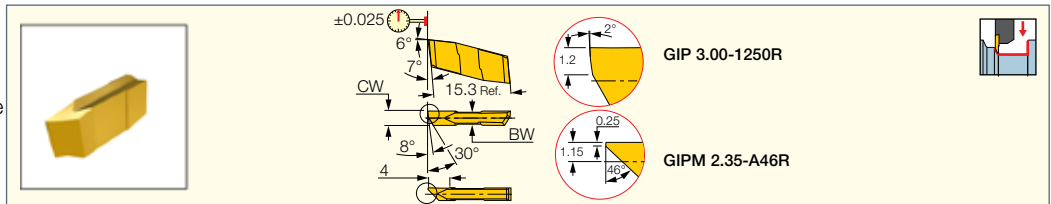

Designation	Dimensions					Tough ↔ Hard			Recommended Machining Data	
	CW	RE	CWTOL ⁽¹⁾	RETOL ⁽²⁾	BW	IC328	IC908	IC20	a _p (mm)	f _{turn} (mm/rev)
GIPM 2.35-A46R/L	2.35	0.05	0.05	0.030	2.20	●	●	●	0.10-1.00	0.02-0.15
GIP 3.00-1250R/L	3.00	0.00	0.05	0.030	2.40	●	●	●	0.10-1.00	0.02-0.15

• Toolholder seat needs to be modified according to insert profile to ensure clearance

• For grooving, reduce cutting speed by 30% and feed by 50%

• For cutting speed recommendations and user guide, see pages 380-395

⁽¹⁾ Cutting width tolerance (+/-)

⁽²⁾ Corner radius tolerance (+/-)



For tools, see pages: C#-GHDR/L (259) • CGHN 26-M (340) • CGHN 32-DGM (342) • CGHN 32-M (341) • CGHN-D (266) • CGHN-DG (267) • CGHN-S (266) • CGPAD (265) • CGPAD-JHP (265) • GHDR/L (short pocket) (259) • GHDR/L-JHP (short pocket) (260) • GHDR/L-JHP-MC (short pocket) (261) • GHGR/L (262) • GHMPR/L (258) • GHMR/L (258) • GHSR/L (357) • GHSR/L-JHP-SL (358)

PICCOACE

PICCO ACE

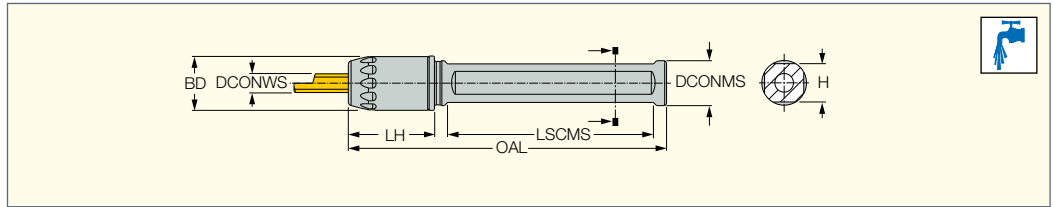
Holder for PICCOCUT Inserts



Designation	DCONMS	DCONWS	BD	OAL	LH	LSCMS	H		
PICCO ACE 12-4	12.00	4.00	14.50	85.00	23.00	53.00	10.3	PL 16 M6-D5	WRENCH ACE 4-5
PICCO ACE 12-5	12.00	5.00	14.50	85.00	23.00	53.00	10.3	PL 16 M6-D5	WRENCH ACE 4-5
PICCO ACE 16-4	16.00	4.00	14.50	85.00	21.50	53.50	14.0	PL 16 M6-D5	WRENCH ACE 4-5
PICCO ACE 16-5	16.00	5.00	14.50	85.00	21.50	53.00	14.0	PL 16 M6-D5	WRENCH ACE 4-5
PICCO ACE 16-6	16.00	6.00	19.90	85.00	23.00	53.50	14.0	PL 16 M6-D5	WRENCH ACE 6-7
PICCO ACE 16-7	16.00	7.00	19.90	85.00	23.00	53.50	14.0	PL 16 M6-D5	WRENCH ACE 6-7
PICCO ACE 20-4	20.00	4.00	14.50	150.00	21.50	118.00	18.0	PL 16 M6-D5	WRENCH ACE 4-5
PICCO ACE 20-5	20.00	5.00	14.50	150.00	21.50	118.00	18.0	PL 16 M6-D5	WRENCH ACE 4-5
PICCO ACE 20-6	20.00	6.00	19.90	150.00	21.50	118.00	18.0	PL 16 M6-D5	WRENCH ACE 6-7
PICCO ACE 20-7	20.00	7.00	19.90	150.00	21.50	118.00	18.0	PL 16 M6-D5	WRENCH ACE 6-7
PICCO ACE 22-4	22.00	4.00	14.50	150.00	21.50	118.00	20.0	PL 16 M6-D5	WRENCH ACE 4-5
PICCO ACE 22-5	22.00	5.00	14.50	150.00	21.50	118.00	20.0	PL 16 M6-D5	WRENCH ACE 4-5
PICCO ACE 22-6	22.00	6.00	19.90	150.00	21.50	118.00	20.0	PL 16 M6-D5	WRENCH ACE 6-7
PICCO ACE 22-7	22.00	7.00	19.90	150.00	21.50	118.00	20.0	PL 16 M6-D5	WRENCH ACE 6-7
PICCO ACE 25-4	25.00	4.00	14.50	150.00	21.50	118.00	20.0	PL 16 M6-D5	WRENCH ACE 4-5
PICCO ACE 25-5	25.00	5.00	14.50	150.00	21.50	118.00	20.0	PL 16 M6-D5	WRENCH ACE 4-5
PICCO ACE 25-6	25.00	6.00	19.90	150.00	21.50	118.00	20.0	PL 16 M6-D5	WRENCH ACE 6-7
PICCO ACE 25-7	25.00	7.00	19.90	150.00	21.50	118.00	20.0	PL 16 M6-D5	WRENCH ACE 6-7

• Holders are suitable for right- and left-hand PICCO inserts

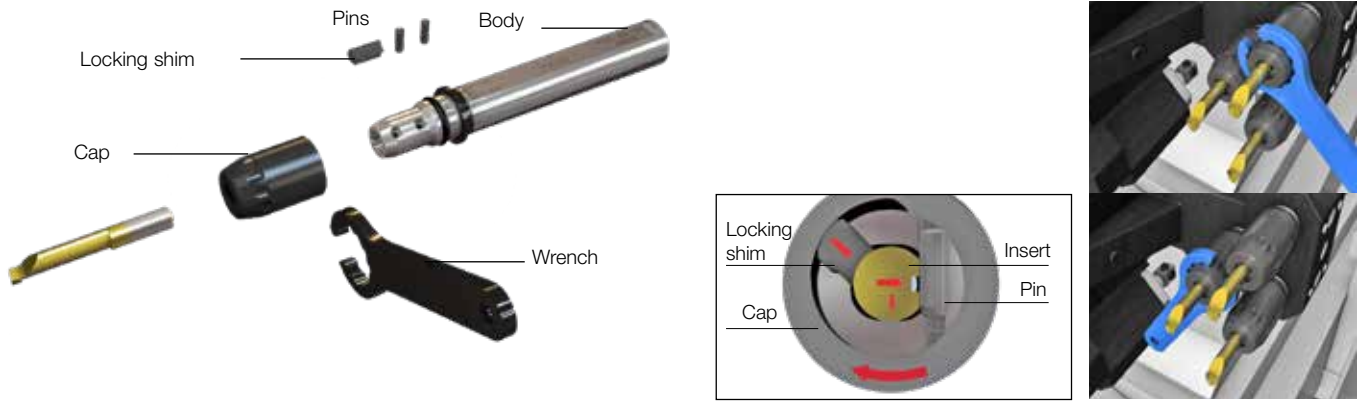



PICCOACE

PICCO ACE Inch

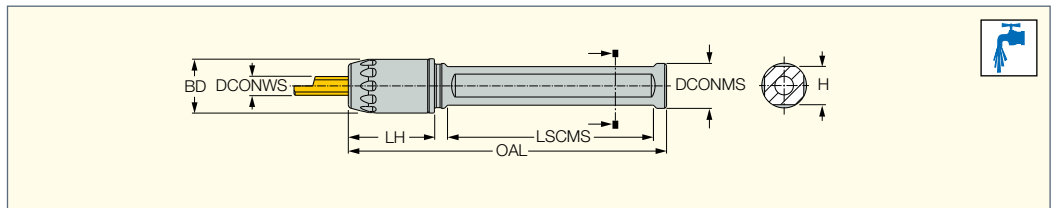
Holder for PICCOCUT Inserts



Designation	DCONMS	DCONWS	BD	OAL	LH	LSCMS	H		
PICCO ACE 12.7-4	.500	.157	.571	3.346	.906	2.087	.457	PL 16 M6-D5	WRENCH ACE 4-5
PICCO ACE 12.7-5	.500	.197	.571	3.346	.906	2.087	.457	PL 16 M6-D5	WRENCH ACE 4-5
PICCO ACE 15.9-4	.625	.157	.571	3.346	.846	2.087	.551	PL 16 M6-D5	WRENCH ACE 4-5
PICCO ACE 15.9-5	.625	.197	.571	3.346	.846	2.087	.551	PL 16 M6-D5	WRENCH ACE 4-5
PICCO ACE 15.9-6	.625	.236	.783	3.346	.906	2.087	.551	PL 16 M6-D5	WRENCH ACE 6-7
PICCO ACE 15.9-7	.625	.276	.783	3.346	.906	2.087	.551	PL 16 M6-D5	WRENCH ACE 6-7
PICCO ACE 19-4	.750	.157	.571	5.906	.846	4.646	.677	PL 16 M6-D5	WRENCH ACE 4-5
PICCO ACE 19-5	.750	.197	.571	5.906	.846	4.646	.677	PL 16 M6-D5	WRENCH ACE 4-5
PICCO ACE 19-6	.750	.236	.783	5.906	.906	4.646	.677	PL 16 M6-D5	WRENCH ACE 6-7
PICCO ACE 19-7	.750	.276	.783	5.906	.906	4.646	.677	PL 16 M6-D5	WRENCH ACE 6-7
PICCO ACE 25.4-4	1.000	.157	.571	5.906	.846	4.646	.905	PL 16 M6-D5	WRENCH ACE 4-5
PICCO ACE 25.4-5	1.000	.197	.571	5.906	.846	4.646	.905	PL 16 M6-D5	WRENCH ACE 4-5
PICCO ACE 25.4-6	1.000	.236	.783	5.906	.846	4.646	.905	PL 16 M6-D5	WRENCH ACE 6-7
PICCO ACE 25.4-7	1.000	.276	.783	5.906	.846	4.646	.905	PL 16 M6-D5	WRENCH ACE 6-7

• Holders are suitable for right- and left-hand PICCO inserts

PICCO*CUT*

PICCO/MG PCO (holder)

Holder for PICCO Inserts and Small Diameter Boring Bars

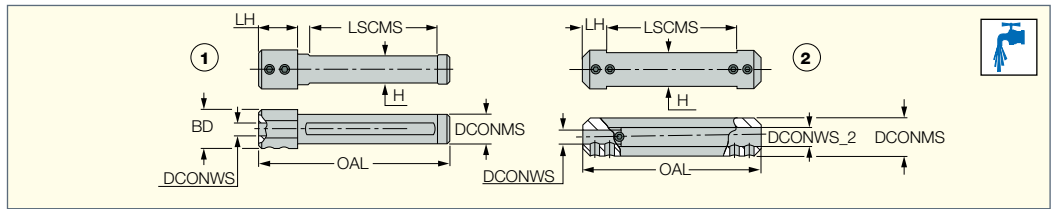

Designation	DCONMS	DCONWS	DCONWS_2	OAL	LH	LSCMS	H	BD	Fig.				
PICCO 12-4-5	12.00	4.00	5.00	75.00	10.00	55.00	10.3	-	2.	SR M5X4-PF	HW 2.5		
PICCO 16-4-5	16.00	4.00	5.00	75.00	10.00	55.00	14.0	-	2.	SR M5X6-PF	HW 2.5		
PICCO 20-4-5	20.00	4.00	5.00	90.00	10.00	70.00	18.0	-	2.	SR M5X6-PF	HW 2.5		
PICCO 22-4-5 ⁽¹⁾	22.00	4.00	5.00	90.00	10.00	70.00	20.0	-	2.	SR M5X6-PF	HW 2.5		
PICCO 16-6-7	16.00	6.00	7.00	75.00	10.00	55.00	14.0	-	2.	SR M5X6-PF	HW 2.5		
PICCO 20-6-7	20.00	6.00	7.00	90.00	10.00	70.00	18.0	-	2.	SR M5X6-PF	HW 2.5		
PICCO 22-6-7 ⁽¹⁾	22.00	6.00	7.00	90.00	10.00	70.00	20.0	-	2.	SR M5X6-PF	HW 2.5		
MG PCO-12-6	12.00	6.00	-	75.00	15.00	50.80	11.0	18.00	1.	SR M5X6-PF	HW 2.5		
MG PCO-16-6-8	16.00	6.00	8.00	75.00	10.00	55.00	14.0	-	2.	SR M5X6-PF	HW 2.5		MG PCO-SPCR8
MG PCO-20-6-8	20.00	6.00	8.00	90.00	10.00	70.00	18.0	-	2.	SR M5X6-PF	HW 2.5		MG PCO-SPCR8
MG PCO-22-6-8 ⁽¹⁾	22.00	6.00	8.00	90.00	10.00	70.00	20.0	-	2.	SR M5X6-PF	HW 2.5		MG PCO-SPCR8
MG PCO-25-6-8	25.00	6.00	8.00	90.00	10.00	70.00	23.0	-	2.	SR M5X6-PF	HW 2.5		MG PCO-SPCR8
MG PCO-16-9	16.00	9.00	-	75.00	15.00	53.00	15.0	20.00	1.	SR M5X6-PF	HW 2.5	PL 16	

• Holders are suitable for right- and left-hand inserts, and boring bars

⁽¹⁾ Tools for Swiss-type CNC

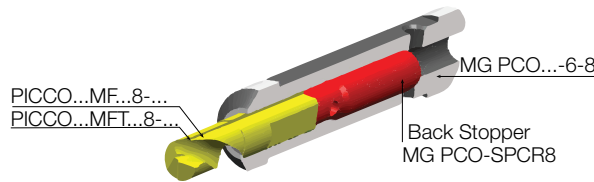

PICCO*CUT*

PICCO/MG PCO (holder)

Inch

Holder for PICCO Inserts and Small Diameter Boring Bars

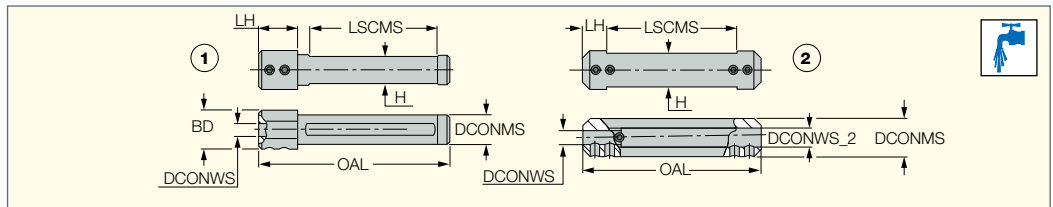

Designation	DCONMS	DCONWS	DCONWS_2	OAL	LH	LSCMS	H	BD	Fig.				
PICCO 12.7-4-5	.500	.157	.197	2.950	.394	2.170	.410	-	2.	SR M5X4-PF	HW 2.5		
PICCO 15.9-4-5	.625	.157	.197	2.950	.394	2.170	.550	-	2.	SR M5X6-PF	HW 2.5		
PICCO 19-4-5	.750	.157	.197	3.540	.394	2.760	.710	-	2.	SR M5X6-PF	HW 2.5		
PICCO 25.4-4-5 ⁽¹⁾	1.000	.157	.197	3.543	.394	2.756	.921	-	2.	SR M5X6-PF	HW 2.5		
PICCO 15.9-6-7	.625	.236	.276	2.950	.394	2.170	.550	-	2.	SR M5X6-PF	HW 2.5		
PICCO 19-6-7	.750	.236	.276	3.540	.394	2.760	.710	-	2.	SR M5X6-PF	HW 2.5		
PICCO 25.4-6-7 ⁽¹⁾	1.000	.236	.276	3.543	.394	2.756	.921	-	2.	SR M5X6-PF	HW 2.5		
MG PCO-12.7-6	.500	.236	-	3.000	.590	2.090	.460	.709	1.	SR M5X6-PF	HW 2.5		
MG PCO-15.9-6-8	.625	.236	.315	3.000	.390	2.170	.551	-	2.	SR M5X6-PF	HW 2.5		MG PCO-SPCR8
MG PCO-19-6-8	.750	.236	.315	3.500	.390	2.760	.709	-	2.	SR M5X6-PF	HW 2.5		MG PCO-SPCR8
MG PCO-25.4-6-8 ⁽¹⁾	1.000	.236	.315	3.543	.394	2.756	.921	-	2.	SR M5X6-PF	HW 2.5		MG PCO-SPCR8
MG PCO-16-9	.630	.354	-	2.953	.591	2.087	.591	.787	1.	SR M5X6-PF	HW 2.5	PL 16	

• Holders are suitable for left- and right-hand inserts, and boring bars

⁽¹⁾ Tools for Swiss-type CNC

PICCOCUT

GHPCOR

Perpendicular Square-Shank Tools for Use on Cross Slide Units of Swiss-Type and Automatic Machines

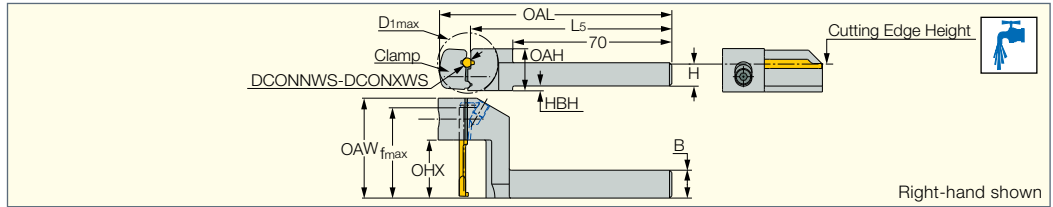

Designation	H	B	OAL	L5	HBH	OAH	OAW	D1 max	OHX ⁽¹⁾	f _{max}	DCONWS ⁽²⁾	DCONXWS
GHPCOR 08-16-4-5	8.0	8.0	102.00	88.00	4.0	15.0	34.00	26.0	16.00	30.0	4.00	5.00
GHPCOR 10-16-4-5	10.0	10.0	102.00	88.00	2.0	18.0	34.00	26.0	16.00	30.0	4.00	5.00
GHPCOR 12-16-4-6	12.0	12.0	102.00	88.00	-	18.0	34.00	26.0	16.00	30.0	4.00	6.00
GHPCOR 12-25-4-6	12.0	12.0	102.00	88.00	-	18.0	43.00	26.0	25.00	39.0	4.00	6.00
GHPCOR 16-16-4-6	16.0	16.0	112.00	98.00	-	22.0	35.00	36.0	16.00	31.0	4.00	6.00
GHPCOR 16-25-4-6	16.0	16.0	112.00	98.00	-	22.0	44.00	36.0	25.00	40.0	4.00	6.00
GHPCOR 16-30-7-8	16.0	16.0	116.00	98.00	-	22.0	49.00	36.0	30.00	45.0	7.00	8.00

• PICCOCUT insert should not exceed OAW • Left-hand holders are available upon request • Coolant tube adapter: KQ2L06-M5 (for 6 mm coolant tube)

⁽¹⁾ Maximum overhang

⁽²⁾ Minimum diameter

Indexing from the top

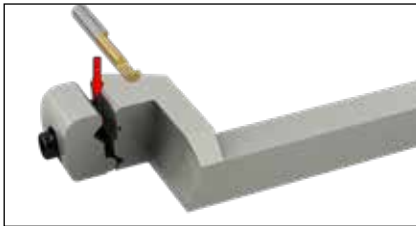

Indexing from the front

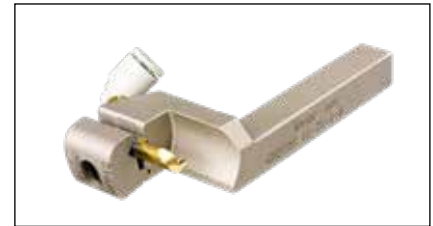
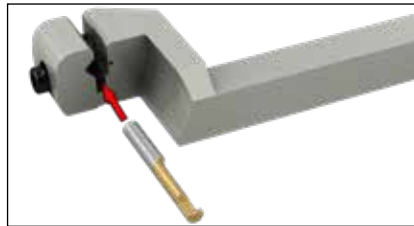

Spare Parts

Designation				
GHPCOR 08-16-4-5	HED 08	SR M4X14 DIN912	HW 3.0	KQ2L06-M5
GHPCOR 10-16-4-5	HED 10	SR M4X14 DIN912	HW 3.0	KQ2L06-M5
GHPCOR 12-16-4-6	HED 12	SR M4X14 DIN912	HW 3.0	KQ2L06-M5
GHPCOR 12-25-4-6	HED 12	SR M4X14 DIN912	HW 3.0	KQ2L06-M5
GHPCOR 16-16-4-6	HED 16-4-6	SR M4X14 DIN912	HW 3.0	KQ2L06-M5
GHPCOR 16-25-4-6	HED 16-4-6	SR M4X14 DIN912	HW 3.0	KQ2L06-M5
GHPCOR 16-30-7-8	HED 16-7-8	SR M4X14 DIN912	HW 3.0	KQ2L06-M5

PICCOACE ITSBORE

PICCO ACE-BH

Holders with Short Shanks for ITS BORE System Carrying PICCOCUT Inserts

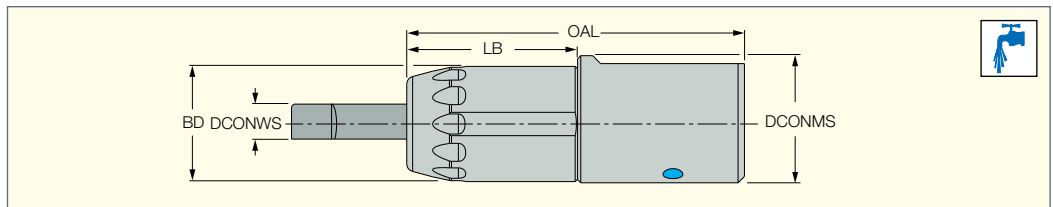

Designation	DCONMS	DCONWS	BD	OAL	LB	
PICCO ACE-BH 16-4	16.00	4.00	14.50	42.50	21.50	WRENCH ACE 4-5
PICCO ACE-BH 16-5	16.00	5.00	14.50	42.50	21.50	WRENCH ACE 4-5
PICCO ACE-BH 16-6	16.00	6.00	19.90	43.50	21.50	WRENCH ACE 6-7
PICCO ACE-BH 16-7	16.00	7.00	19.90	43.50	21.50	WRENCH ACE 6-7

• Holders are suitable for right- and left-hand PICCO inserts

The PICCO-ACE-BH Holders Can Carry a Wide Range of PICCOCUT Insert Geometries

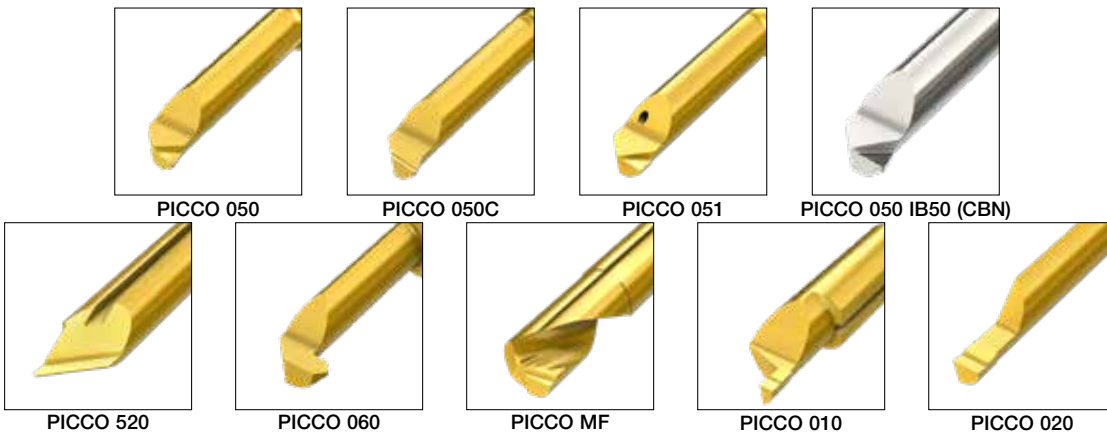

PICCO^{CUT}

PICCO R/L 050, 053, 055

Inserts for Internal Turning and Chamfering

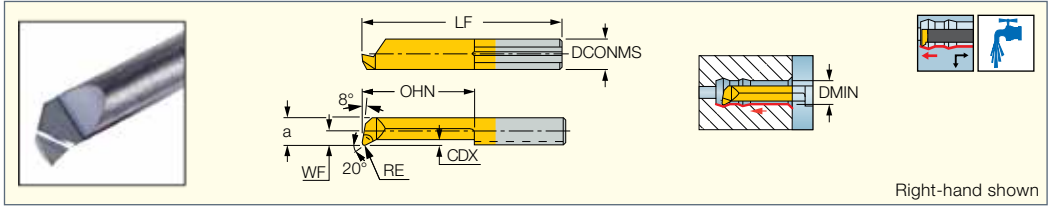

Designation	Dimensions								Tough ↔ Hard	
	DCONMS	WF	a	LF	OHN	RE	CDX	DMIN	IC228	IC908
PICCO R 050.06-2 ⁽¹⁾	4.00	-	0.50	20.00	2.0	0.04	0.08	0.60	●	●
PICCO R 050.06-3 ⁽¹⁾	4.00	-	0.50	20.00	3.0	0.04	0.08	0.60	●	●
PICCO R 050.08-4	4.00	-	0.70	20.00	4.0	0.04	0.08	0.80		●
PICCO R/L 050.1-5	4.00	-	0.90	20.00	4.5	0.05	0.10	1.00	●	●
PICCO R/L 050.1-7	4.00	-	0.90	22.00	6.5	0.05	0.10	1.00	●	●
PICCO R 050.15-5	4.00	-	1.30	19.00	5.0	0.05	0.10	1.50		●
PICCO R 050.15-10	4.00	-	1.30	24.00	10.0	0.05	0.10	1.50		●
PICCO R/L 050.2-5	4.00	-	1.70	19.00	4.0	0.05	0.10	2.00	●	●
PICCO R 055.2-5	4.00	-	1.70	19.00	5.0	0.05	0.10	2.00		●
PICCO R/L 050.2-10	4.00	-	1.70	24.00	9.0	0.05	0.10	2.00	●	●
PICCO R 055.2-10	4.00	-	1.70	24.00	10.0	0.05	0.10	2.00		●
PICCO R/L 050.2-15	4.00	-	1.70	29.00	14.0	0.05	0.10	2.00	●	●
PICCO R 055.2-15	4.00	-	1.70	29.00	15.0	0.05	0.10	2.00		●
PICCO R 050.25-5	4.00	0.20	2.20	19.00	5.0	0.05	0.15	2.50		●
PICCO R 050.25-10	4.00	0.20	2.20	24.00	10.0	0.05	0.15	2.50		●
PICCO R 050.25-16	4.00	0.20	2.20	30.00	16.0	0.05	0.15	2.50		●
PICCO R 053.3-10	4.00	0.60	2.60	24.00	9.0	0.03	0.20	2.80		●
PICCO R 055.3-10	4.00	0.60	2.60	24.00	10.0	0.05	0.20	2.80		●
PICCO R/L 050.3-10	4.00	0.60	2.60	24.00	9.0	0.10	0.20	2.80	●	●
PICCO R 053.3-16	4.00	0.60	2.60	30.00	15.0	0.03	0.20	2.80		●
PICCO R 055.3-16	4.00	0.60	2.60	30.00	16.0	0.05	0.20	2.80		●
PICCO R/L 050.3-16	4.00	0.60	2.60	30.00	15.0	0.10	0.20	2.80	●	●
PICCO R 053.3-20	4.00	0.60	2.60	34.00	19.0	0.03	0.20	2.80		●
PICCO R/L 050.3-20	4.00	0.60	2.60	34.00	19.0	0.10	0.20	2.80	●	●
PICCO R 050.35-10	4.00	1.10	3.10	24.00	10.0	0.10	0.25	3.50		●
PICCO R 050.35-16	4.00	1.10	3.10	30.00	16.0	0.10	0.25	3.50		●
PICCO R 050.35-20	4.00	1.10	3.10	34.00	20.0	0.10	0.25	3.50		●
PICCO R 050.35-24	4.00	1.10	3.10	38.00	24.0	0.10	0.25	3.50		●
PICCO R 053.4-10	4.00	1.50	3.50	24.00	9.0	0.03	0.30	4.00		●
PICCO R 055.4-10	4.00	1.50	3.50	24.00	10.0	0.05	0.30	4.00		●
PICCO R/L 050.4-10	4.00	1.50	3.50	24.00	9.0	0.10	0.30	4.00	●	●
PICCO R 053.4-16	4.00	1.50	3.50	30.00	15.0	0.03	0.30	4.00		●
PICCO R 055.4-16	4.00	1.50	3.50	30.00	16.0	0.05	0.30	4.00		●
PICCO R/L 050.4-16	4.00	1.50	3.50	30.00	15.0	0.10	0.30	4.00	●	●
PICCO R 053.4-20	4.00	1.50	3.50	34.00	19.0	0.03	0.30	4.00		●
PICCO R 055.4-20	4.00	1.50	3.50	34.00	20.0	0.05	0.30	4.00		●
PICCO R/L 050.4-20	4.00	1.50	3.50	34.00	19.0	0.10	0.30	4.00	●	●
PICCO R/L 050.4-24	4.00	1.50	3.50	38.00	23.0	0.10	0.30	4.00	●	●
PICCO R/L 050.4-28	4.00	1.50	3.50	42.00	27.0	0.10	0.30	4.00	●	●
PICCO R 055.4-28	4.00	1.50	3.50	42.00	28.0	0.05	0.50	4.00		●
PICCO R 055.5-10	5.00	1.90	4.40	25.00	9.0	0.05	0.50	5.00		●
PICCO R/L 050.5-10	5.00	1.90	4.40	25.00	9.0	0.15	0.50	5.00	●	●
PICCO R 055.5-15	5.00	1.90	4.40	30.00	14.0	0.05	0.50	5.00		●
PICCO R/L 050.5-15	5.00	1.90	4.40	30.00	14.0	0.15	0.50	5.00	●	●
PICCO R 055.5-20	5.00	1.90	4.40	35.00	19.0	0.05	0.50	5.00		●
PICCO R/L 050.5-20	5.00	1.90	4.40	35.00	19.0	0.15	0.50	5.00	●	●
PICCO R 055.5-25	5.00	1.90	4.40	40.00	24.0	0.05	0.50	5.00		●
PICCO R/L 050.5-25	5.00	1.90	4.40	40.00	24.0	0.15	0.50	5.00	●	●
PICCO R 055.5-30	5.00	1.90	4.40	45.00	29.0	0.05	0.50	5.00		●
PICCO R/L 050.5-30	5.00	1.90	4.40	45.00	29.0	0.15	0.50	5.00	●	●
PICCO R/L 050.5-35	5.00	1.90	4.40	50.00	34.0	0.15	0.50	5.00	●	●
PICCO R 055.6-15	6.00	2.30	5.30	30.00	14.0	0.05	0.50	6.00		●
PICCO R/L 050.6-15	6.00	2.30	5.30	30.00	14.0	0.15	0.50	6.00	●	●
PICCO R 055.6-22	6.00	2.30	5.30	37.00	21.0	0.05	0.50	6.00		●
PICCO R/L 050.6-22	6.00	2.30	5.30	37.00	21.0	0.15	0.50	6.00	●	●
PICCO R 055.6-25	6.00	2.30	5.30	40.00	24.0	0.05	0.50	6.00		●
PICCO R/L 050.6-25	6.00	2.30	5.30	40.00	24.0	0.15	0.50	6.00	●	●
PICCO R 055.6-30	6.00	2.30	5.30	45.00	29.0	0.05	0.50	6.00		●
PICCO R/L 050.6-30	6.00	2.30	5.30	45.00	29.0	0.15	0.50	6.00	●	●

• Specify right- or left-hand bars • For cutting speed recommendations, see pages 380-395
⁽¹⁾ Maximum D.O.C.=0.01-0.03 mm, maximum feed=0.01 mm/rev.

PICCO^{CUT}

PICCO R/L 050, 053, 055 (continued)

Inserts for Internal Turning and Chamfering

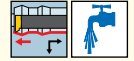
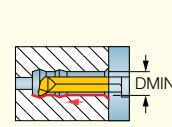
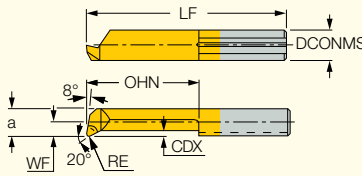

Right-hand shown

Designation	Dimensions								Tough ↔ Hard	
	DCONMS	WF	a	LF	OHN	RE	CDX	DMIN	IC228	IC908
PICCO R/L 050.6-35	6.00	2.30	5.30	50.00	34.0	0.15	0.50	6.00	●	●
PICCO R/L 050.6-42	6.00	2.30	5.30	57.00	41.0	0.15	0.50	6.00	●	●
PICCO R/L 050.7-20	7.00	2.80	6.30	35.00	19.0	0.15	0.60	6.80	●	●
PICCO R/L 050.7-25	7.00	2.80	6.30	40.00	24.0	0.15	0.60	6.80	●	●
PICCO R/L 050.7-30	7.00	2.80	6.30	45.00	29.0	0.15	0.60	6.80	●	●
PICCO R/L 050.7-35	7.00	2.80	6.30	50.00	34.0	0.15	0.60	6.80	●	●
PICCO R/L 050.7-40	7.00	2.80	6.30	55.00	39.0	0.15	0.60	6.80	●	●
PICCO R/L 050.7-45	7.00	2.80	6.30	60.00	44.0	0.15	0.60	6.80	●	●
PICCO R/L 050.7-50	7.00	2.80	6.30	65.00	49.0	0.15	0.60	6.80	●	●

• Specify right- or left-hand bars • For cutting speed recommendations, see pages 380-395
 (1) Maximum D.O.C.=0.01-0.03 mm, maximum feed=0.01 mm/rev.

PICCO^{CUT}

PICCO R/L 050-C
Inserts with Chipformers for Internal Boring and Profiling

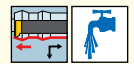
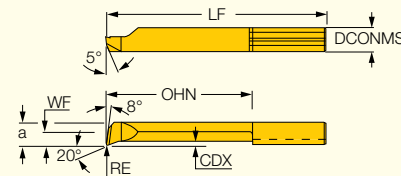

Right-hand shown

Designation	Dimensions								IC908
	DCONMS	WF	a	LF	OHN	CDX	DMIN	RE	
PICCO R/L 050.4-10C	4.00	1.50	3.50	24.00	10.0	0.30	4.00	0.20	●
PICCO R/L 050.4-20C	4.00	1.50	3.50	34.00	20.0	0.30	4.00	0.20	●
PICCO R/L 050.4-24C	4.00	1.50	3.50	38.00	24.0	0.30	4.00	0.20	●
PICCO R/L 050.4-28C	4.00	1.50	3.50	42.00	28.0	0.30	4.00	0.20	●
PICCO R 050.4-16C	4.00	1.50	3.50	30.00	16.0	0.30	4.00	0.20	●
PICCO R/L 050.5-10C	5.00	1.90	4.40	25.00	10.0	0.50	5.00	0.20	●
PICCO R/L 050.5-15C	5.00	1.90	4.40	30.00	15.0	0.50	5.00	0.20	●
PICCO R/L 050.5-20C	5.00	1.90	4.40	35.00	20.0	0.50	5.00	0.20	●
PICCO R/L 050.5-25C	5.00	1.90	4.40	40.00	25.0	0.50	5.00	0.20	●
PICCO R/L 050.5-30C	5.00	1.90	4.40	45.00	30.0	0.50	5.00	0.20	●
PICCO R/L 050.5-35C	5.00	1.90	4.40	50.00	35.0	0.50	5.00	0.20	●
PICCO R/L 050.6-15C	6.00	2.30	5.30	30.00	15.0	0.50	6.00	0.20	●
PICCO R/L 050.6-22C	6.00	2.30	5.30	37.00	22.0	0.50	6.00	0.20	●
PICCO R/L 050.6-25C	6.00	2.30	5.30	40.00	25.0	0.50	6.00	0.20	●
PICCO R/L 050.6-30C	6.00	2.30	5.30	45.00	30.0	0.50	6.00	0.20	●
PICCO R/L 050.6-35C	6.00	2.30	5.30	50.00	35.0	0.50	6.00	0.20	●
PICCO R/L 050.6-42C	6.00	2.30	5.30	57.00	42.0	0.50	6.00	0.20	●
PICCO R/L 050.7-20C	7.00	2.80	6.30	35.00	20.0	0.60	6.80	0.20	●
PICCO R/L 050.7-25C	7.00	2.80	6.30	40.00	25.0	0.60	6.80	0.20	●
PICCO R/L 050.7-30C	7.00	2.80	6.30	45.00	30.0	0.60	6.80	0.20	●
PICCO R/L 050.7-35C	7.00	2.80	6.30	50.00	35.0	0.60	6.80	0.20	●
PICCO R/L 050.7-40C	7.00	2.80	6.30	55.00	40.0	0.60	6.80	0.20	●
PICCO L 050.7-50C	7.00	2.80	6.30	65.00	50.0	0.60	6.80	0.20	●

• All left-hand inserts on request • For cutting speed recommendations, see pages 380-395

Stainless Steel 316L

PICCO R 050.6-35C with Chipbreaker

f= 0.03 mm/rev

f= 0.05 mm/rev

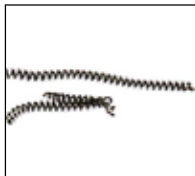

PICCO R 050.6-35 Standard

f= 0.03 mm/rev

f= 0.05 mm/rev



PICCO CUT

PICCO R/LM

Profiling Inserts with Coolant Channels Optimized for Machining Medical Parts

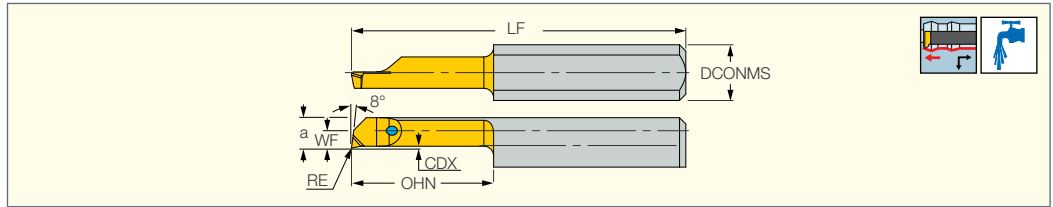

Designation	Dimensions								IC909
	DMIN	OHN	DCONMS	WF	a	CDX	RE	LF	
PICCO R/LM050.05-2	0.50	2.0	4.00	0.20	0.40	0.02	0.02	20.00	●
PICCO R/LM050.08-4	0.80	4.0	4.00	0.20	0.70	0.03	0.02	20.00	●
PICCO R/LM050.1-5	1.00	5.0	4.00	0.40	0.90	0.05	0.02	20.00	●
PICCO R/LM050.1-7	1.00	7.0	4.00	0.40	0.90	0.05	0.02	22.00	●
PICCO R/LM050.15-5	1.50	5.0	4.00	0.60	1.15	0.08	0.02	19.00	●
PICCO R/LM050.15-10	1.50	10.0	4.00	0.60	1.15	0.08	0.02	24.00	●
PICCO R/LM050.2-5	2.00	5.0	4.00	0.80	1.70	0.08	0.02	19.00	●
PICCO R/LM050.2-10	2.00	10.0	4.00	0.80	1.70	0.08	0.02	24.00	●
PICCO R/LM050.25-5	2.50	5.0	4.00	0.20	2.20	0.10	0.02	19.00	●
PICCO R/LM050.25-10	2.50	10.0	4.00	0.20	2.20	0.10	0.02	24.00	●
PICCO R/LM050.3-10	3.00	10.0	4.00	0.60	2.60	0.15	0.02	24.00	●
PICCO R/LM050.3-16	3.00	16.0	4.00	0.60	2.60	0.15	0.02	30.00	●
PICCO R/LM050.35-10	3.50	10.0	4.00	1.10	3.40	0.17	0.02	24.00	●
PICCO R/LM050.35-16	3.50	16.0	4.00	1.10	3.10	0.17	0.02	30.00	●
PICCO R/LM050.35-20	3.50	20.0	4.00	1.10	3.10	0.17	0.02	34.00	●
PICCO R/LM050.4-10	4.00	10.0	4.00	1.50	3.50	0.20	0.02	24.00	●
PICCO R/LM050.4-16	4.00	16.0	4.00	1.50	3.50	0.20	0.02	30.00	●
PICCO R/LM050.4-20	4.00	20.0	4.00	1.50	3.50	0.20	0.02	34.00	●
PICCO R/LM050.4-24	4.00	24.0	4.00	1.50	3.50	0.20	0.02	38.00	●

• An optimized insert geometry and carbide grade for machining medical parts made from titanium, medical standard stainless steel and other difficult to machine materials.

PICCO CUT

PICCO R 050.20

Inserts for Internal Turning and Chamfering Next to the Bottom of Blind Holes

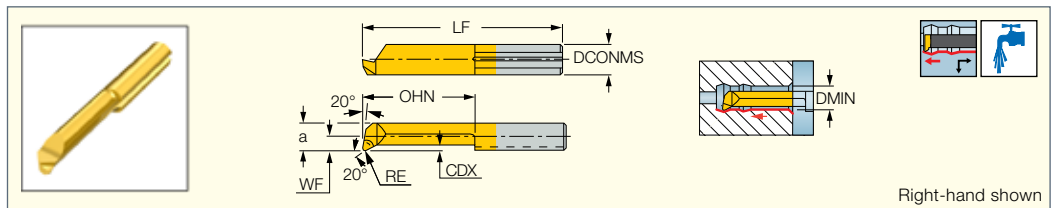

Designation	Dimensions								IC908
	DCONMS	WF	a	LF	OHN	RE	CDX	DMIN	
PICCO R 050.20.2-10	4.00	-	1.70	24.00	10.0	0.05	0.10	2.00	●
PICCO R 050.20.3-10	4.00	0.60	2.60	24.00	10.0	0.10	0.20	2.80	●
PICCO R 050.20.4-16	4.00	1.50	3.50	30.00	16.0	0.10	0.30	4.00	●
PICCO R 050.20.5-20	5.00	1.90	4.40	35.00	19.0	0.15	0.50	5.00	●

• Specify right- or left-hand bars • For cutting speed recommendations, see pages 380-395

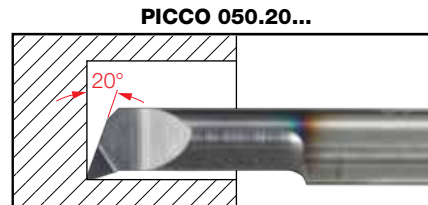
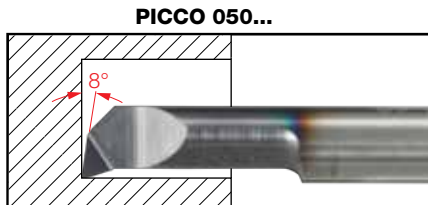

PICCO^{CUT}

PICCO R/LHD 050
 Inserts for Internal Turning
 and Chamfering of Hard
 Steel - Up to 65 HRC

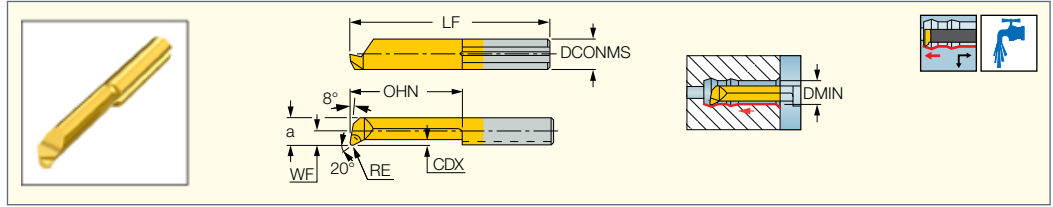

Designation	Dimensions								IC902
	DCONMS	WF	a	LF	OHN	RE	CDX	DMIN	
PICCO R/LHD 050.2-5	4.00	-	1.70	19.00	4.0	0.05	0.10	2.00	●
PICCO R/LHD 050.3-10	4.00	0.60	2.60	24.00	9.0	0.10	0.20	2.80	●
PICCO R/LHD 050.3-16	4.00	0.60	2.60	30.00	15.0	0.10	0.20	2.80	●
PICCO R/LHD 050.4-10	4.00	1.50	3.50	24.00	9.0	0.10	0.30	4.00	●
PICCO R/LHD 050.4-20	4.00	1.50	3.50	34.00	19.0	0.10	0.30	4.00	●
PICCO R/LHD 050.5-10	5.00	1.90	4.40	25.00	9.0	0.15	0.50	5.00	●
PICCO R/LHD 050.5-15	5.00	1.90	4.40	30.00	14.0	0.15	0.50	5.00	●
PICCO R/LHD 050.6-15	6.00	2.30	5.30	30.00	14.0	0.15	0.50	6.00	●
PICCO R/LHD 050.7-20	7.00	2.80	6.30	35.00	19.0	0.15	0.60	6.80	●
PICCO R/LHD 050.7-25	7.00	2.80	6.30	40.00	24.0	0.15	0.60	6.80	●
PICCO R/LHD 050.7-35	7.00	2.80	6.30	50.00	34.0	0.15	0.60	6.80	●

• Specify right- or left-hand bars • For cutting speed recommendations, see pages 380-395

PICCO^{CUT}

PICCO R 050 (CBN)
 CBN Tipped Inserts for
 Internal Turning, Profiling and
 Chamfering of Hard Steel

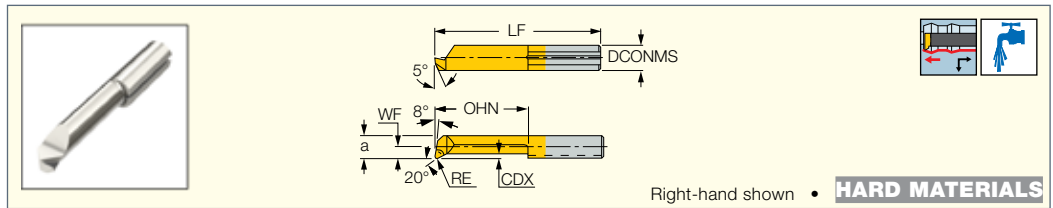

Designation	Dimensions								IB55
	DCONMS	WF	a	LF	OHN	CDX	DMIN	RE	
PICCO R 050.3-10B	4.00	0.60	2.60	25.50	10.0	0.20	2.80	0.10	●
PICCO R 050.4-10B	4.00	1.50	3.50	25.50	10.0	0.30	4.00	0.10	●
PICCO R 050.5-15B	5.00	1.90	4.40	31.50	15.0	0.50	5.00	0.15	●
PICCO R 050.6-15B	6.00	2.30	5.30	31.50	15.0	0.50	6.00	0.15	●
PICCO R 050.7-20B	7.00	2.80	6.30	36.50	20.0	0.60	6.80	0.15	●

• It is not recommended to use coolant when machining with CBN tipped tools • Available on request only • For cutting speed recommendations, see pages 380-395

PICCO CUT

PICCO R/LX050
Reinforced Boring Inserts
with Internal Coolant Holes

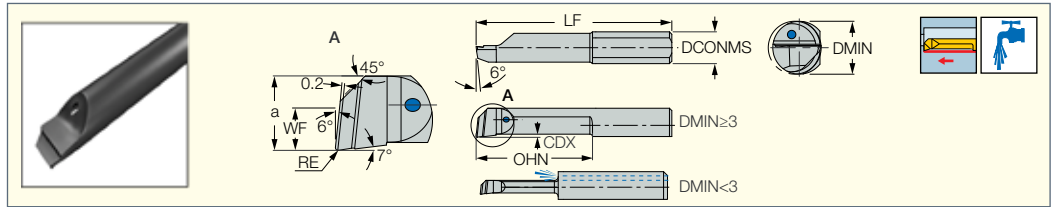

Designation	Dimensions								IC908
	DCONMS	WF	a	RE	LF	OHN	CDX	DMIN	
PICCO R/LX050.2-5R15	4.00	-	1.80	0.15	19.00	5.0	0.10	2.00	●
PICCO R/LX050.2-10R05	4.00	-	1.80	0.05	24.00	10.0	0.10	2.00	●
PICCO R/LX050.2-10R15	4.00	-	1.80	0.15	24.00	10.0	0.10	2.00	●
PICCO R/LX050.3-16R10	4.00	0.70	2.70	0.10	30.00	16.0	0.15	3.00	●
PICCO R/LX050.3-16R20	4.00	0.70	2.70	0.20	30.00	16.0	0.15	3.00	●
PICCO R/LX050.4-10R10	4.00	1.60	3.60	0.10	24.00	10.0	0.20	4.00	●
PICCO R/LX050.4-10R20	4.00	1.60	3.60	0.20	24.00	10.0	0.20	4.00	●
PICCO R/LX050.4-16R10	4.00	1.60	3.60	0.10	30.00	16.0	0.20	4.00	●
PICCO R/LX050.4-16R20	4.00	1.60	3.60	0.20	30.00	16.0	0.20	4.00	●
PICCO R/LX050.5-15R10	5.00	2.10	4.60	0.10	30.00	15.0	0.30	5.00	●
PICCO R/LX050.5-15R20	5.00	2.10	4.60	0.20	30.00	15.0	0.30	5.00	●
PICCO R/LX050.5-25R10	5.00	2.10	4.60	0.10	40.00	25.0	0.30	5.00	●
PICCO R/LX050.5-25R20	5.00	2.10	4.60	0.20	40.00	25.0	0.30	5.00	●
PICCO R/LX050.6-15R10	6.00	2.50	5.50	0.10	30.00	15.0	0.40	6.00	●
PICCO R/LX050.6-15R20	6.00	2.50	5.50	0.20	30.00	15.0	0.40	6.00	●
PICCO R/LX050.6-22R20	6.00	2.50	5.50	0.20	37.00	22.0	0.40	6.00	●
PICCO R/LX050.6-35R20	6.00	2.50	5.50	0.20	50.00	35.0	0.40	6.00	●

• Left-hand inserts on request • For cutting speed recommendations, see pages 380-395

PICCO CUT

PICCO R/L 090
Inserts for Internal
Turning and Profiling

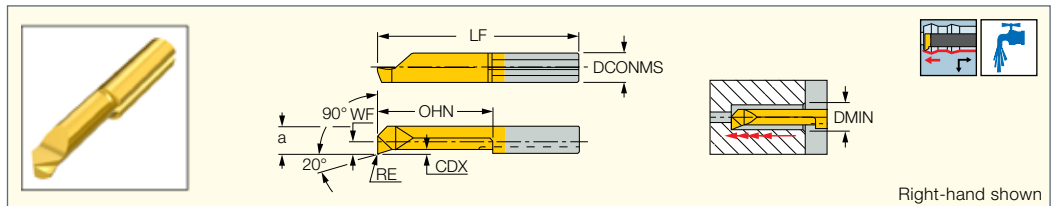

Right-hand shown

Designation	Dimensions								IC228
	DCONMS	WF	a	LF	OHN	RE	CDX	DMIN	
PICCO R/L 090.3-10	4.00	0.60	2.60	24.00	9.0	0.10	0.20	2.80	●
PICCO R/L 090.3-16	4.00	0.60	2.60	30.00	15.0	0.10	0.20	2.80	●
PICCO R/L 090.4-10	4.00	1.50	3.50	24.00	9.0	0.10	0.30	4.00	●
PICCO R/L 090.4-16	4.00	1.50	3.50	30.00	15.0	0.10	0.30	4.00	●
PICCO R/L 090.5-10	5.00	1.90	4.40	25.00	9.0	0.15	0.50	5.00	●
PICCO R/L 090.5-15	5.00	1.90	4.40	30.00	14.0	0.15	0.50	5.00	●
PICCO R/L 090.5-20	5.00	1.90	4.40	35.00	19.0	0.15	0.50	5.00	●

• Specify right- or left-hand bars • For cutting speed recommendations, see pages 380-395

PICCO^{CUT}

PICCO R/L 080

Inserts for Internal Back Turning

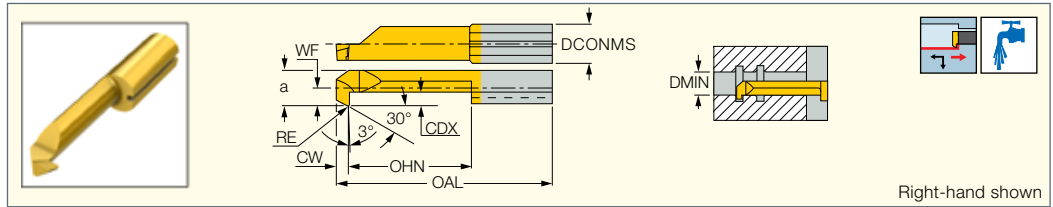

Right-hand shown

Designation	Dimensions									
	DCONMS	WF	a	CW	OAL	OHN ⁽¹⁾	RE	CDX	DMIN	IC228
PICCO R/L 080.0003-15	4.00	0.60	2.60	1.50	29.00	14.0	0.10	0.50	3.00	●
PICCO R/L 080.0003-20	4.00	0.60	2.60	1.50	34.00	19.0	0.10	0.50	3.00	●
PICCO R/L 080.0004-15	4.00	1.50	3.50	1.50	29.00	14.0	0.15	0.80	4.00	●
PICCO R/L 080.0004-25	4.00	1.50	3.50	1.50	39.00	24.0	0.15	0.80	4.00	●
PICCO R/L 080.0005-20	5.00	1.90	4.40	1.50	35.00	19.0	0.20	1.00	5.00	●
PICCO R/L 080.0005-30	5.00	1.90	4.40	1.50	45.00	29.0	0.20	1.00	5.00	●
PICCO R/L 080.0006-20	6.00	2.30	5.30	1.50	35.00	19.0	0.20	1.80	6.00	●
PICCO R/L 080.0006-30	6.00	2.30	5.30	1.50	45.00	29.0	0.20	1.80	6.00	●
PICCO R/L 080.0007-20	7.00	2.80	6.30	1.50	35.00	19.0	0.20	2.50	7.00	●
PICCO R/L 080.0007-30	7.00	2.80	6.30	1.50	45.00	29.0	0.20	2.50	7.00	●

● Specify right- or left-hand bars • For cutting speed recommendations, see pages 380-395
⁽¹⁾ Minimum overhang

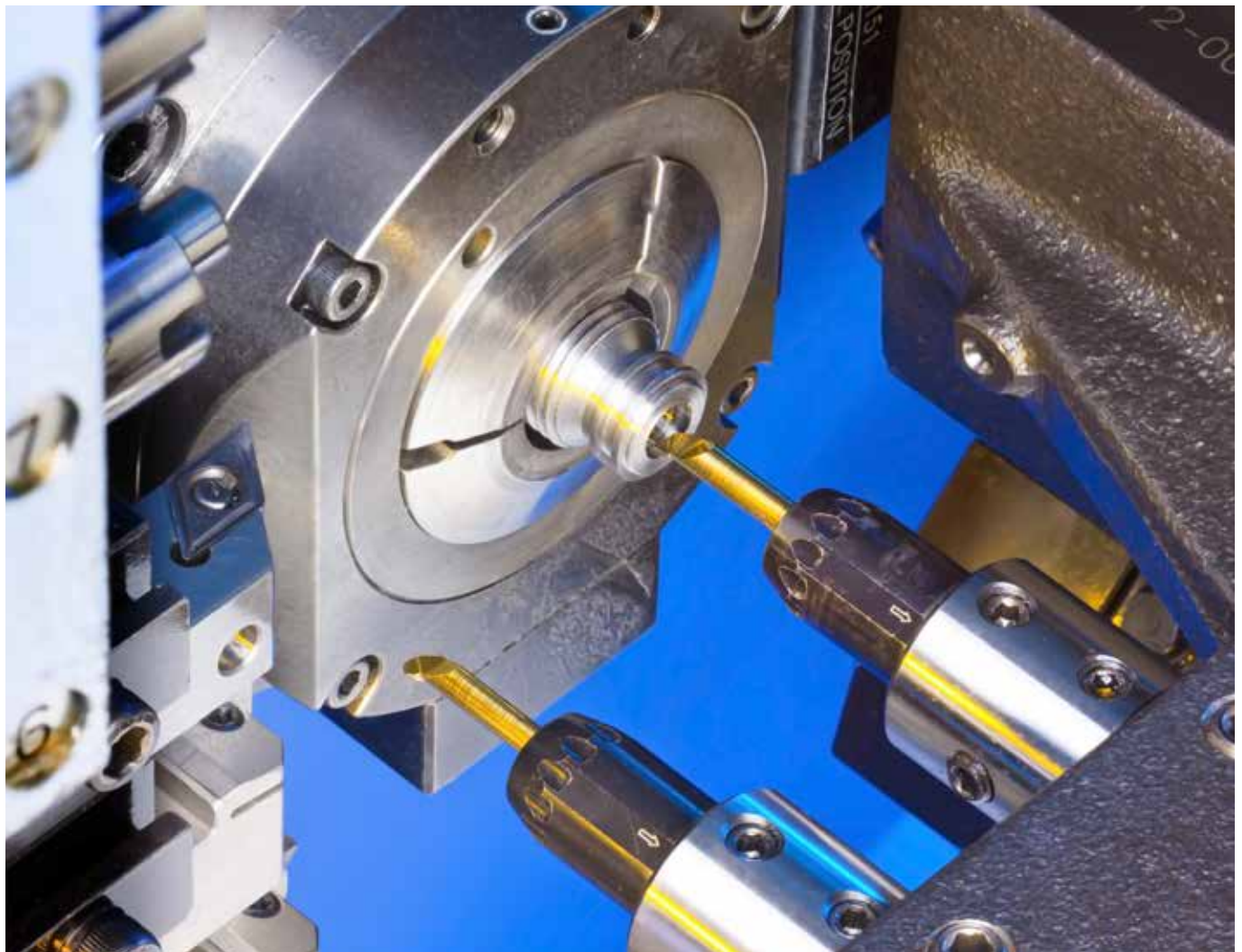

PICCO^{CUT}

PICCO R/L 002-007

Inserts for Internal Grooving and Turning

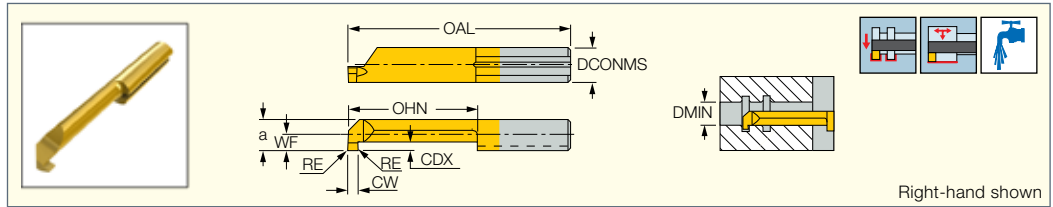

Designation	Dimensions									Tough ↔ Hard	
	DCONMS	CW	WF	a	RE	OAL	OHN	CDX	DMIN	IC228	IC908
PICCO R 002.0050-5	4.00	0.50	0.20	1.80	0.00	19.00	5.0	0.40	2.00		●
PICCO R 002.0050-10	4.00	0.50	0.20	1.80	0.00	24.00	10.0	0.40	2.00		●
PICCO R/L 002.0050-15	4.00	0.50	0.20	1.80	0.00	29.00	15.0	0.40	2.00		●
PICCO R 003.0070-5	4.00	0.70	0.70	2.70	0.00	19.00	5.0	0.60	3.00		●
PICCO R 003.0070-10	4.00	0.70	0.70	2.70	0.00	24.00	10.0	0.60	3.00		●
PICCO R 003.0070-16	4.00	0.70	0.70	2.70	0.00	29.00	15.0	0.60	3.00		●
PICCO R/L 004.0100-10	4.00	1.00	1.50	3.50	0.00	24.00	9.0	0.80	4.00	●	
PICCO R/L 004.0100-16	4.00	1.00	1.50	3.50	0.00	30.00	15.0	0.80	4.00	●	
PICCO R/L 004.0100-20	4.00	1.00	1.50	3.50	0.00	34.00	19.0	0.80	4.00	●	
PICCO R/L 005.0100-10	5.00	1.00	1.90	4.40	0.00	25.00	9.0	1.00	5.00	●	
PICCO R/L 005.0100-15	5.00	1.00	1.90	4.40	0.00	30.00	14.0	1.00	5.00	●	
PICCO R/L 005.0100-20	5.00	1.00	1.90	4.40	0.00	35.00	19.0	1.00	5.00	●	
PICCO R/L 005.0100-25	5.00	1.00	1.90	4.40	0.00	40.00	24.0	1.00	5.00	●	
PICCO R/L 005.0100-30	5.00	1.00	1.90	4.40	0.00	45.00	29.0	1.00	5.00	●	
PICCO R/L 005.0150-10	5.00	1.50	1.90	4.40	0.00	25.00	9.0	1.00	5.00	●	
PICCO R/L 005.0150-15	5.00	1.50	1.90	4.40	0.00	30.00	14.0	1.00	5.00	●	
PICCO R 005M0150-15	5.00	1.50	1.90	4.00	0.10	30.00	14.0	1.00	5.00		●
PICCO R/L 005.0150-20	5.00	1.50	1.90	4.40	0.00	35.00	19.0	1.00	5.00	●	
PICCO R/L 005.0150-25	5.00	1.50	1.90	4.40	0.00	40.00	24.0	1.00	5.00	●	
PICCO R/L 005.0150-30	5.00	1.50	1.90	4.40	0.00	45.00	29.0	1.00	5.00	●	
PICCO R/L 005.0200-10	5.00	2.00	1.90	4.40	0.00	25.00	9.0	1.00	5.00	●	
PICCO R/L 005.0200-15	5.00	2.00	1.90	4.40	0.00	30.00	14.0	1.00	5.00	●	
PICCO R/L 005.0200-20	5.00	2.00	1.90	4.40	0.00	35.00	19.0	1.00	5.00	●	
PICCO R/L 005.0200-25	5.00	2.00	1.90	4.40	0.00	40.00	24.0	1.00	5.00	●	
PICCO R/L 005.0200-30	5.00	2.00	1.90	4.40	0.00	45.00	29.0	1.00	5.00	●	
PICCO R/L 006.0100-10	6.00	1.00	2.30	5.30	0.00	25.00	9.0	1.80	6.00	●	
PICCO R/L 006.0100-15	6.00	1.00	2.30	5.30	0.00	30.00	14.0	1.80	6.00	●	
PICCO R/L 006.0100-22	6.00	1.00	2.30	5.30	0.00	37.00	21.0	1.80	6.00	●	
PICCO R/L 006.0100-25	6.00	1.00	2.30	5.30	0.00	40.00	24.0	1.80	6.00	●	
PICCO R/L 006.0100-30	6.00	1.00	2.30	5.30	0.00	45.00	29.0	1.80	6.00	●	
PICCO R/L 006.0150-10	6.00	1.50	2.30	5.30	0.00	25.00	9.0	1.80	6.00	●	
PICCO R/L 006.0150-15	6.00	1.50	2.30	5.30	0.00	30.00	14.0	1.80	6.00	●	
PICCO R/L 006.0150-22	6.00	1.50	2.30	5.30	0.00	37.00	21.0	1.80	6.00	●	
PICCO R/L 006.0150-25	6.00	1.50	2.30	5.30	0.00	40.00	24.0	1.80	6.00	●	
PICCO R/L 006.0150-30	6.00	1.50	2.30	5.30	0.00	45.00	29.0	1.80	6.00	●	
PICCO R/L 006.0200-10	6.00	2.00	2.30	5.30	0.00	25.00	9.0	1.80	6.00	●	
PICCO R/L 006.0200-15	6.00	2.00	2.30	5.30	0.00	30.00	14.0	1.80	6.00	●	
PICCO R 006M0200-15	6.00	2.00	2.30	5.30	0.10	30.00	14.0	1.80	6.00		●
PICCO R/L 006.0200-22	6.00	2.00	2.30	5.30	0.00	37.00	21.0	1.80	6.00	●	
PICCO R/L 006.0200-25	6.00	2.00	2.30	5.30	0.00	40.00	24.0	1.80	6.00	●	
PICCO R/L 006.0200-30	6.00	2.00	2.30	5.30	0.00	45.00	29.0	1.80	6.00	●	
PICCO R/L 007.0100-10	7.00	1.00	2.80	6.30	0.00	25.00	9.0	2.50	6.80	●	
PICCO R/L 007.0100-15	7.00	1.00	2.80	6.30	0.00	30.00	14.0	2.50	6.80	●	
PICCO R/L 007.0100-22	7.00	1.00	2.80	6.30	0.00	37.00	21.0	2.50	6.80	●	
PICCO R/L 007.0100-25	7.00	1.00	2.80	6.30	0.00	40.00	24.0	2.50	6.80	●	
PICCO R/L 007.0100-30	7.00	1.00	2.80	6.30	0.00	45.00	29.0	2.50	6.80	●	
PICCO R/L 007.0150-10	7.00	1.50	2.80	6.30	0.00	25.00	9.0	2.50	6.80	●	
PICCO R/L 007.0150-15	7.00	1.50	2.80	6.30	0.00	30.00	14.0	2.50	6.80	●	
PICCO R/L 007.0150-22	7.00	1.50	2.80	6.30	0.00	37.00	21.0	2.50	6.80	●	
PICCO R/L 007.0150-25	7.00	1.50	2.80	6.30	0.00	40.00	24.0	2.50	6.80	●	
PICCO R/L 007.0150-30	7.00	1.50	2.80	6.30	0.00	45.00	29.0	2.50	6.80	●	
PICCO R/L 007.0200-10	7.00	2.00	2.80	6.30	0.00	25.00	9.0	2.50	6.80	●	
PICCO R/L 007.0200-15	7.00	2.00	2.80	6.30	0.00	30.00	14.0	2.50	6.80	●	
PICCO R 007M0200-15	7.00	2.00	2.80	6.30	0.10	30.00	14.0	2.50	6.80		●
PICCO R/L 007.0200-22	7.00	2.00	2.80	6.30	0.00	37.00	21.0	2.50	6.80	●	
PICCO R/L 007.0200-25	7.00	2.00	2.80	6.30	0.00	40.00	24.0	2.50	6.80	●	
PICCO R/L 007.0200-30	7.00	2.00	2.80	6.30	0.00	45.00	29.0	2.50	6.80	●	

• All carbide bars with sharp corners • Specify right- or left-hand bars • For cutting speed recommendations, see pages 380-395

PICCOCUT

PICCO R/L 004-007 (radius)

Full Radius Inserts for Internal Profiling

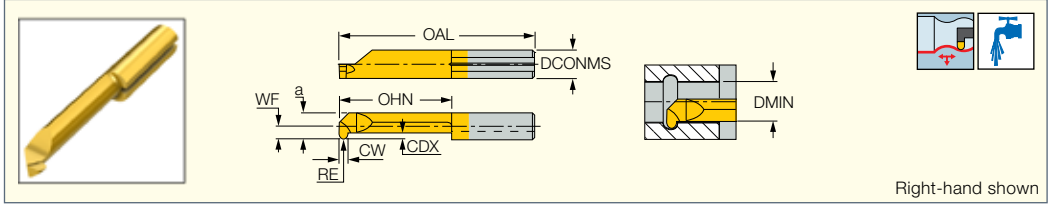

Right-hand shown

Designation	Dimensions									IC228
	DCONMS	CW	WF	a	RE	OAL	OHN ⁽¹⁾	CDX	DMIN	
PICCO R/L 004.0.50-16	4.00	1.00	1.50	3.50	0.50	30.00	15.0	0.80	4.00	●
PICCO R/L 005.0.50-20	5.00	1.00	1.90	4.40	0.50	35.00	19.0	1.00	5.00	●
PICCO R/L 005.0.75-20	5.00	1.50	1.90	4.40	0.75	35.00	19.0	1.00	5.00	●
PICCO R/L 005.1.00-20	5.00	2.00	1.90	4.40	1.00	35.00	19.0	1.00	5.00	●
PICCO R/L 006.0.50-25	6.00	1.00	2.30	5.30	0.50	40.00	24.0	1.80	6.00	●
PICCO R/L 006.0.75-25	6.00	1.50	2.30	5.30	0.75	40.00	24.0	1.80	6.00	●
PICCO R/L 006.1.00-25	6.00	2.00	2.30	5.30	1.00	40.00	24.0	1.80	6.00	●
PICCO R/L 007.0.50-30	7.00	1.00	2.80	6.30	0.50	45.00	29.0	2.50	6.80	●
PICCO R/L 007.0.75-30	7.00	1.50	2.80	6.30	0.75	45.00	29.0	2.50	6.80	●
PICCO R/L 007.1.00-30	7.00	2.00	2.80	6.30	1.00	45.00	29.0	2.50	6.80	●

- Specify right- or left-hand bars
- For cutting speed recommendations, see pages 380-395
- ⁽¹⁾ Minimum overhang

PICCOCUT

PICCO R/L 060

Inserts for Internal Turning and 45° Chamfering

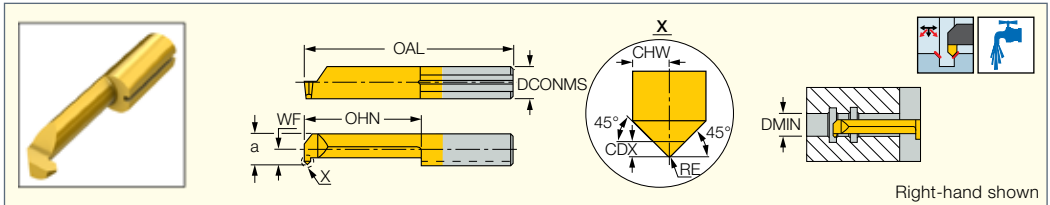

Right-hand shown

Designation	Dimensions									Tough ← Hard	
	DCONMS	RE	CHW	WF	a	OHN ⁽¹⁾	OAL	CDX	DMIN	IC228	IC908
PICCO R/L 060.5-15	5.00	0.20	1.0	1.90	4.40	14.0	30.00	0.70	5.00	●	
PICCO R/L 060.5-20	5.00	0.20	1.0	1.90	4.40	19.0	35.00	0.70	5.00	●	
PICCO R 060.6-20	6.00	0.20	1.0	2.30	5.30	20.0	35.00	0.70	6.00		●
PICCO R 060.6-25	6.00	0.20	1.0	2.30	5.30	25.0	40.00	0.70	6.00		●
PICCO R/L 060.7-20	7.00	0.20	1.0	2.80	6.30	19.0	35.00	0.70	6.80	●	
PICCO R 060.7-40	7.00	0.20	1.0	2.80	6.30	40.0	55.00	0.70	6.80		●

- Specify right- or left-hand bars
- For cutting speed recommendations, see pages 380-395
- ⁽¹⁾ Minimum overhang

PICCOCUT

PICCO R/L 520

Inserts for Internal Chamfering

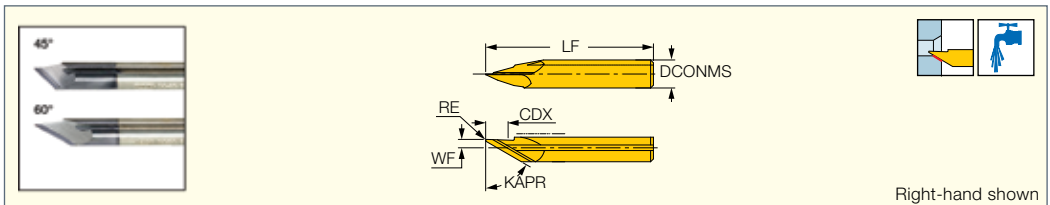

Right-hand shown

Designation	Dimensions							IC908
	DCONMS	WF	KAPR	LF	RE	CDX	DMIN	
PICCO R/L 520.0045-15	5.00	1.50	45.0	30.00	0.20	3.50	1.00	●
PICCO R/L 520.0060-15	5.00	1.50	60.0	30.00	0.20	4.00	1.00	●

- Left hand inserts on request
- For cutting speed recommendations, see pages 380-395

PICCO CUT

PICCO R/L 047

Inserts for Internal Deep Profiling

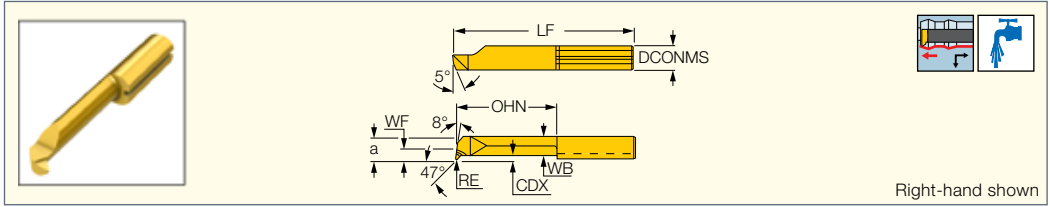

Designation	Dimensions									
	DCONMS	WF	a	LF	OHN	WB	CDX	DMIN	RE	IC908
PICCO R/L 047.4-20	4.00	1.50	3.50	34.00	20.0	3.00	0.30	4.00	0.15	●
PICCO R/L 047.5-25	5.00	1.90	4.40	40.00	25.0	3.80	0.50	5.00	0.15	●
PICCO R/L 047.6-30	6.00	2.30	5.30	45.00	30.0	4.50	0.50	6.00	0.15	●
PICCO R 047.T6-22	6.00	2.30	5.30	37.00	22.0	3.40	1.80	6.00	0.15	●
PICCO R 047.T6-30	6.00	2.30	5.30	45.00	30.0	3.40	1.80	6.00	0.15	●

• Left hand inserts on request • For cutting speed recommendations, see pages 380-395

PICCO CUT

PICCO R/L 070

Back Chamfering Inserts for Pre-Parting Operations

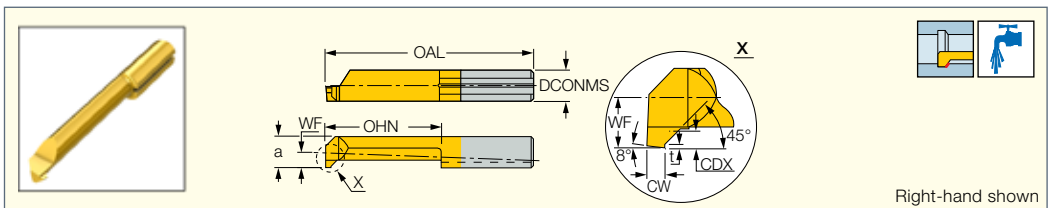

Designation	Dimensions									
	DCONMS	CW	WF	a	OHN ⁽¹⁾	OAL	t	CDX	DMIN	IC228
PICCO R/L 070.5-15	5.00	1.00	1.90	4.40	15.0	30.00	0.20	1.00	5.00	●
PICCO R/L 070.5-20	5.00	1.00	1.90	4.40	20.0	35.00	0.20	1.00	5.00	●

• All carbide bars with sharp corners • Specify right- or left-hand bars
⁽¹⁾ Minimum overhang

PICCO CUT

KIT PICCO SET

Contains 2 Toolholders and a Set of Solid Carbide Miniature Turning and Grooving Boring Bars

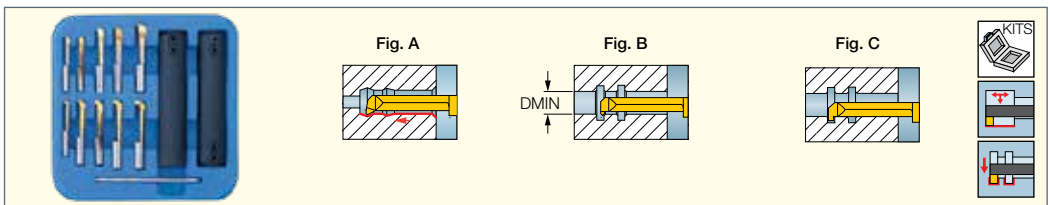

Designation	DMIN	Qty
KIT PICCO SET-1R	3.00	12

Designation	DMIN	OHN	CDX	CW	Pcs.	Fig.	Description
PICCO 16-4-5					1x		Holder
PICCO 16-6-7					1x		Holder
PICCO R 050.3-16	3.0	15	—	—	1x	A	Mini carbide bar
PICCO R 050.4-16	4.0	15	—	—	1x	A	Mini carbide bar
PICCO R 050.5-20	5.0	19	—	—	1x	A	Mini carbide bar
PICCO R 050.6-22	6.0	21	—	—	1x	A	Mini carbide bar
PICCO R 060.5-20	5.0	19	—	—	1x	B	Mini carbide bar
PICCO R 004.0100-16	4.0	15	0.8	1.0	1x	C	Mini carbide bar
PICCO R 005.0150-20	5.0	19	1.0	1.5	1x	C	Mini carbide bar
PICCO R 005.0200-20	5.0	19	1.0	2.0	1x	C	Mini carbide bar
PICCO R 006.0150-22	6.0	21	1.8	1.5	1x	C	Mini carbide bar
PICCO R 006.0200-22	6.0	21	1.8	2.0	1x	C	Mini carbide bar

PICCO CUT

PICCO ISO Full Profile
Inserts for ISO Standard
Full Profile Thread

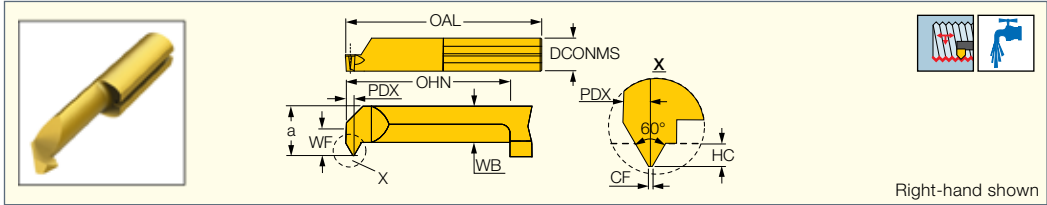

Designation	Dimensions											IC908
	TP	DCONMS	WF	a	OAL	OHN	WB	PDX	HC	CF	DMIN	
PICCO R/L 105.0510-15	1.000	5.00	1.90	4.40	30.00	15.0	3.30	0.6	0.54	0.12	4.80	●
PICCO R/L 106.0612-15	1.250	6.00	2.30	5.30	30.00	15.0	3.40	0.7	0.67	0.15	6.00	●
PICCO R/L 106.0815-15	1.500	6.00	2.30	5.30	30.00	15.0	3.40	0.8	0.81	0.18	6.00	●
PICCO R/L 107.0815-15	1.500	7.00	2.80	6.30	30.00	15.0	3.80	0.8	0.81	0.18	7.00	●

PICCO CUT

PICCO ISO Full Profile Fine
Inserts for ISO Fine Pitch
Full Profile Thread

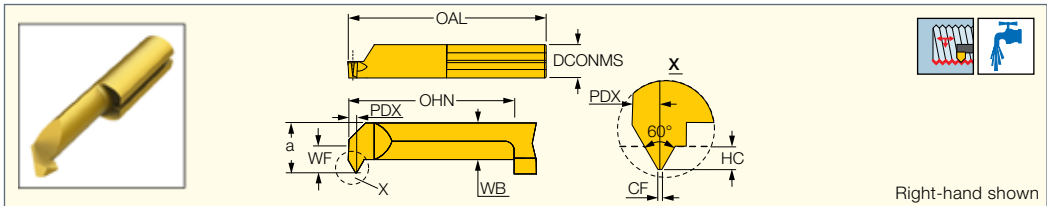

Designation	Dimensions											IC908
	TP	DCONMS	WF	a	OAL	OHN	WB	PDX	HC	CF	DMIN	
PICCO R/L 104.0205-15	0.500	5.00	1.50	3.50	30.00	15.0	2.40	0.4	0.27	0.06	4.00	●
PICCO R/L 105.0205-15	0.500	5.00	1.90	4.40	30.00	15.0	3.30	0.4	0.27	0.06	5.00	●
PICCO R/L 105.0407-15	0.750	5.00	1.90	4.40	30.00	15.0	3.30	0.5	0.40	0.09	5.00	●
PICCO R/L 106.0510-15	1.000	6.00	2.30	5.30	30.00	15.0	3.40	0.6	0.54	0.12	6.00	●

ISCARTHREAD

PICCO CUT

PICCO R/L-60°-Thread
Inserts with a 60° Internal
Thread Profile for 2.4 mm
Min. Bore Diameter

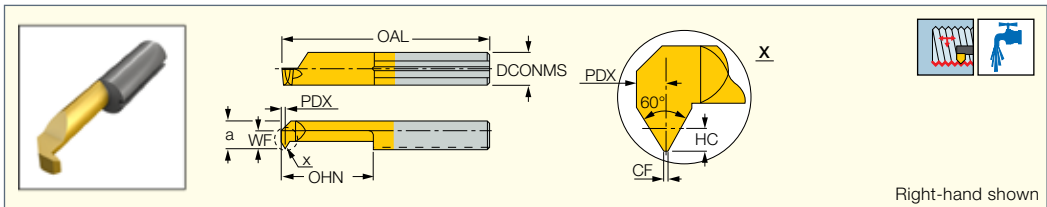

Designation	Dimensions										Tough ← Hard	
	TP	DCONMS	HC	CF	PDX	WF	a	OHN ⁽¹⁾	OAL	DMIN	IC228	IC908
PICCO R 003.0105-8	0.500	4.00	0.27	0.04	0.3	0.30	2.30	8.0	22.00	2.40		●
PICCO R 004.0105-10	0.500	4.00	0.27	0.09	0.4	1.00	3.00	10.0	24.00	3.20		●
PICCO R/L 004.0205-15	0.500	4.00	0.27	0.06	0.4	1.50	3.50	15.0	30.00	4.00	●	
PICCO R/L 005.0205-15	0.500	5.00	0.27	0.06	0.4	1.90	4.40	15.0	30.00	5.00	●	
PICCO R/L 005.0407-15	0.750	5.00	0.40	0.09	0.5	1.90	4.40	15.0	30.00	5.00	●	●
PICCO R 005.0407-20	0.750	5.00	0.40	0.09	0.5	1.90	4.40	20.0	35.00	5.00		●
PICCO R/L 005.0510-15	1.000	5.00	0.55	0.12	0.6	1.90	4.40	15.0	30.00	4.80	●	
PICCO R 005.0510-20	1.000	5.00	0.55	0.12	0.6	1.90	4.40	20.0	35.00	4.80		●
PICCO R/L 006.0510-15	1.000	6.00	0.55	0.12	0.6	2.30	5.30	15.0	30.00	6.00	●	
PICCO R 006.0510-22	1.000	6.00	0.55	0.12	0.6	2.30	5.30	22.0	37.00	6.00		●
PICCO R/L 006.0612-15	1.250	6.00	0.68	0.15	0.7	2.30	5.30	15.0	30.00	6.00	●	
PICCO R 006.0612-22	1.250	6.00	0.68	0.15	0.7	2.30	5.30	22.0	37.00	6.00		●
PICCO R/L 006.0815-15	1.500	6.00	0.81	0.18	0.8	2.30	5.30	15.0	30.00	6.00	●	
PICCO R 006.0815-22	1.500	6.00	0.81	0.18	0.8	2.30	5.30	22.0	37.00	6.00		●
PICCO R/L 007.0815-15	1.500	7.00	0.81	0.18	0.8	2.70	6.30	15.0	30.00	7.00	●	

• For detailed cutting data, see pages 380-395

⁽¹⁾ Thread pitch

ISCAR THREAD

PICCO CUT

PICCO-55°-Thread
 Inserts for 55° Internal Threading Profile

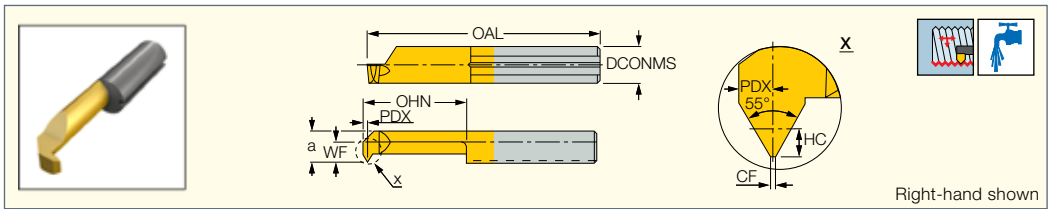

Right-hand shown

Designation	Dimensions											IC228
	DCONMS	TPIX ⁽¹⁾	TPIN ⁽²⁾	HC	CF	PDX	WF	a	OHN ⁽³⁾	OAL	DMIN	
PICCO R 005.5548-15	5.00	48.00	24	0.40	0.06	0.5	1.90	4.40	15.0	30.00	4.80	●
PICCO R 006.5548-15	6.00	48.00	24	0.40	0.06	0.5	2.30	5.30	15.0	30.00	6.00	●
PICCO R 006.5524-15	6.00	24.00	16	0.81	0.12	0.8	2.30	5.30	15.0	30.00	6.00	●
PICCO R 007.5524-15	7.00	24.00	16	0.81	0.12	0.8	2.80	6.30	15.0	30.00	7.00	●

• All mini-bars have sharp corners • For detailed cutting data, see pages 380-395

⁽¹⁾ Threads per inch maximum

⁽²⁾ Threads per inch minimum

⁽³⁾ Minimum overhang

MINICHAM

MGUHR

Solid Carbide Bars for Internal Turning and Threading at 4 mm Minimum Bore Diameter

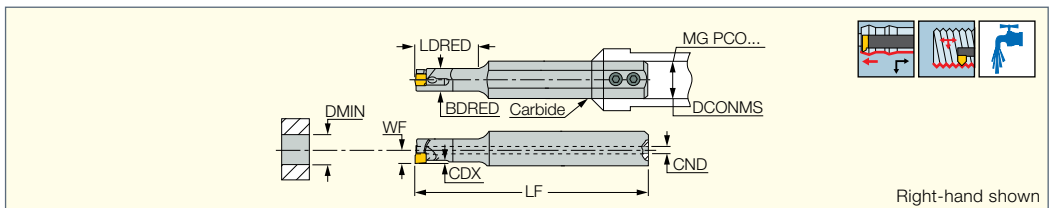

Right-hand shown

Designation	DMIN	CDX ⁽²⁾	WF ⁽³⁾	DCONMS	LF	LDRED	BDRED	CND
MGUHR 06-04L10 ⁽¹⁾	4.00	0.50	2.17	6.00	62.00	10.0	3.45	1.3
MGUHR 06-04L20	4.00	0.50	2.17	6.00	62.00	20.0	3.45	1.3

⁽¹⁾ DMIN for turning 4.0 mm & CDX 0.43 mm; DMIN for threading 5.0 mm & CDX 1.00 mm

⁽²⁾ Cutting depth maximum

⁽³⁾ WF=2.17 for turning, WF=2.7 for threading

For inserts, see pages: UMGR (373) • UMGR-A55 (373) • UMGR-A60 (373)

For holders, see pages: PICCO/MG PCO (holder) (360)

Mounting Operation



Dismounting Operation



MINICHAM

UMGR

Miniature Indexable Inserts for Internal Turning

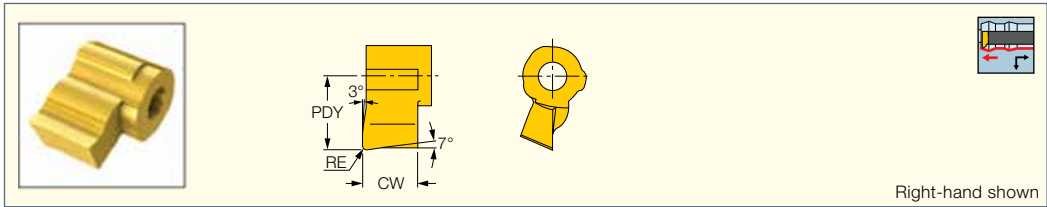

Right-hand shown

Dimensions						IC508
Designation	CW	RE	PDY	DMIN		
UMGR 4.0-0.0	1.63	0.00	2.20	4.00		•
UMGR 4.0-0.1	1.63	0.10	1.60	4.00		•

For tools, see pages: MGUHR (372)

ISCARTHREAD

MINICHAM

UMGR-A55

Mini Indexable Inserts with Whitworth Partial Profile for Threading in 5.2 mm and Larger Holes

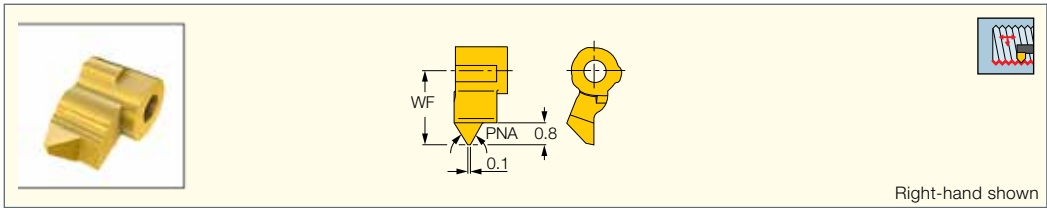

Right-hand shown

Dimensions								IC508
Designation	WF	PNA	TPIX ⁽¹⁾	TPIN ⁽²⁾	TPN ⁽³⁾	TPX ⁽⁴⁾	DMIN	
UMGR 4.0-A55	2.70	55	48.00	18	0.500	1.400	5.20	•

- (1) Threads per inch maximum
- (2) Threads per inch minimum
- (3) Thread pitch minimum (mm)
- (4) Thread pitch maximum (mm)

For tools, see pages: MGUHR (372)

ISCARTHREAD

MINICHAM

UMGR-A60

Mini Indexable Inserts with a 60° Partial Profile for Threading in 5.2 mm and Larger Holes

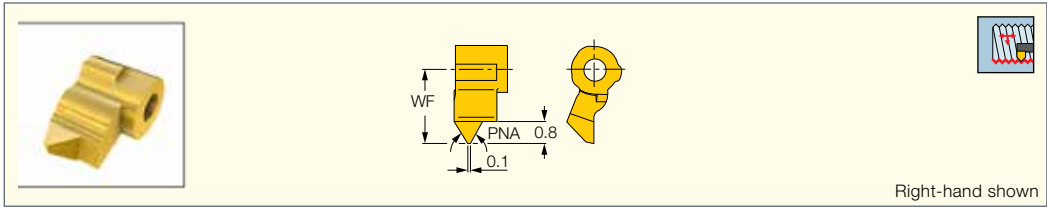

Right-hand shown

Dimensions							IC508
Designation	PNA	WF	DMIN	TPN ⁽¹⁾	TPX ⁽²⁾		
UMGR 4.0-A60	60	2.70	5.20	0.500	1.250		•

• For detailed cutting data, see pages 380-395.

- (1) Thread pitch minimum (mm)
- (2) Thread pitch maximum (mm)

For tools, see pages: MGUHR (372)



MIFHR

Bars for Face and Internal Grooving, Undercutting and Threading Inserts

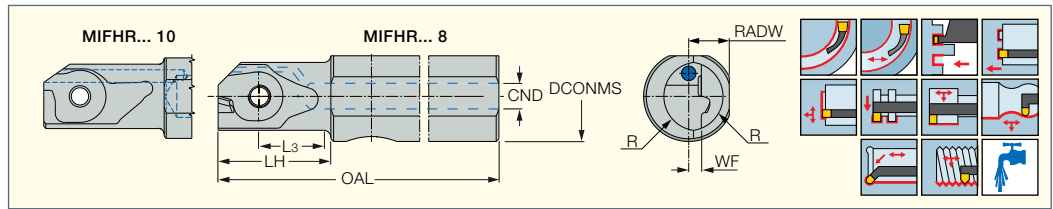

Designation	DCONMS	CND	WF	RADW	OAL	L3	LH	R	Insert			
MIFHR 8SC-8-SRK ⁽¹⁾	8.00	1.2	1.4	3.70	75.00	7.40	11.7	3.80	MI.R 8	SR 14-297	T-8/5	
MIFHR 10C-8	10.00	5.0	1.4	4.50	102.50	7.40	12.5	3.80	MI.R 8	SR 14-297	T-8/5	
MIFHR 12C-10 ⁽²⁾	12.00	6.0	2.4	5.50	90.00	11.20	17.2	4.60	MI.R 10	SR 34-506	T-9/5	
MIFHR 12C-8	12.00	5.0	1.4	5.50	102.50	7.40	12.5	3.80	MI.R 8	SR 14-297	T-8/5	
MIFHR 16C-10 ⁽²⁾	16.00	6.0	2.4	7.50	90.00	11.20	17.2	4.60	MI.R 10	SR 34-506	T-9/5	
MIFHR 16C-15	16.00	8.0	2.7	7.50	100.00	12.50	19.0	10.30	MI.R 15	SR 34-506/L	T-9/5	PL 16
MIFHR 20C-15	20.00	8.5	4.7	9.00	100.00	12.50	19.0	11.30	MI.R 15	SR 34-506/L	T-9/5	PL 20

⁽¹⁾ Solid carbide shank
⁽²⁾ Only face grooving inserts are available for this tool

For inserts, see pages: MEFL (545) • MIFR (545) • MIGR 8 (374) • MITR 8-MT (375) • MIUR 8 (374)
 For holders, see pages: PICCO/MG PCO (holder) (360)



MIGR 8

Internal Shallow Grooving Inserts

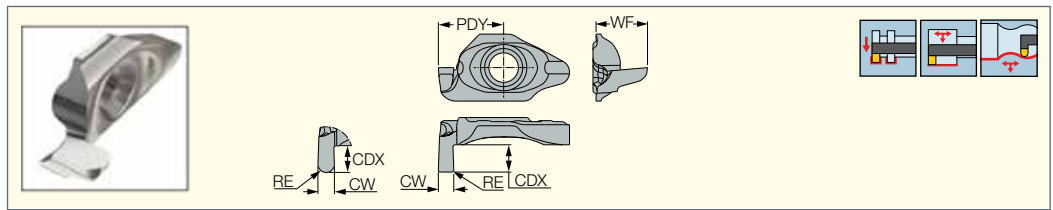

Designation	Dimensions								IC908	Recommended Machining Data		
	CW	RE	CWTOL ⁽¹⁾	RETOL ⁽²⁾	DMIN	CDX	PDY	WF		a _p (mm)	f turn (mm/rev)	f groove (mm/rev)
MIGR 8-0.50-0.00	0.50	-	0.02	0.020	8.50	1.40	6.30	4.00	●	0.05-0.50	0.03-0.10	0.01-0.03
MIGR 8-1.00-0.05	1.00	0.05	0.02	0.020	8.50	1.40	6.80	4.00	●	0.05-0.50	0.03-0.10	0.01-0.03
MIGR 8-1.20-0.05	1.20	0.05	0.02	0.020	9.20	2.10	6.80	4.70	●	0.05-0.50	0.03-0.10	0.01-0.03
MIGR 8-1.20-0.60	1.20	0.60	0.02	0.020	9.20	2.10	6.80	4.70	●	0.05-0.50	0.03-0.10	0.01-0.03
MIGR 8-1.50-0.05	1.50	0.05	0.02	0.020	9.20	2.10	6.80	4.70	●	0.05-0.50	0.03-0.10	0.01-0.03
MIGR 8-1.60-0.80	1.60	0.80	0.02	0.020	9.20	2.10	6.80	4.70	●	0.05-0.50	0.03-0.10	0.01-0.03
MIGR 8-2.00-0.10	2.00	0.10	0.02	0.020	8.90	1.80	6.80	4.40	●	0.05-0.50	0.03-0.10	0.01-0.03
MIGR 8-2.00-1.00	2.00	1.00	0.02	0.020	9.20	2.10	6.80	4.70	●	0.05-0.50	0.03-0.10	0.01-0.03

• For cutting speed recommendations, see pages 380-395

⁽¹⁾ Cutting width tolerance (+/-)
⁽²⁾ Corner radius tolerance (+/-)

For tools, see pages: MIFHR (374)



MIUR 8

45° Full Radius Internal Undercutting Inserts

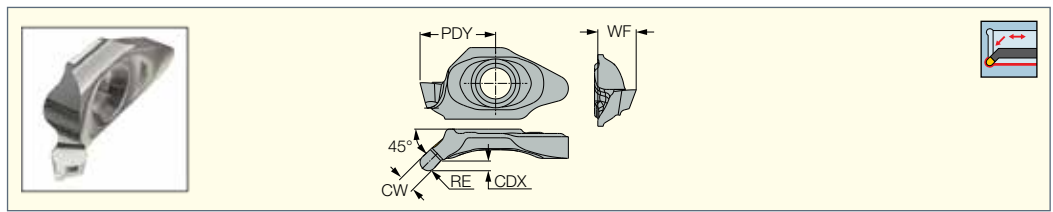

Designation	Dimensions								IC908	Recommended Machining Data		
	CW	RE	CWTOL ⁽¹⁾	RETOL ⁽²⁾	DMIN	CDX	PDY	WF		a _p (mm)	f turn (mm/rev)	f groove (mm/rev)
MIUR 8-1.00-0.50	1.00	0.50	0.02	0.020	8.00	1.10	6.70	3.60	●	0.03-0.50	0.03-0.10	0.01-0.03
MIUR 8-1.5-0.75	1.50	0.75	0.02	0.020	8.10	1.20	6.70	3.60	●	0.03-0.50	0.03-0.10	0.01-0.03
MIUR 8-2.00-1.00	2.00	1.00	0.02	0.020	8.30	1.36	6.70	3.60	●	0.03-0.50	0.03-0.10	0.01-0.03

• For cutting speed recommendations, see pages 380-395

⁽¹⁾ Cutting width tolerance (+/-)
⁽²⁾ Corner radius tolerance (+/-)

For tools, see pages: MIFHR (374)

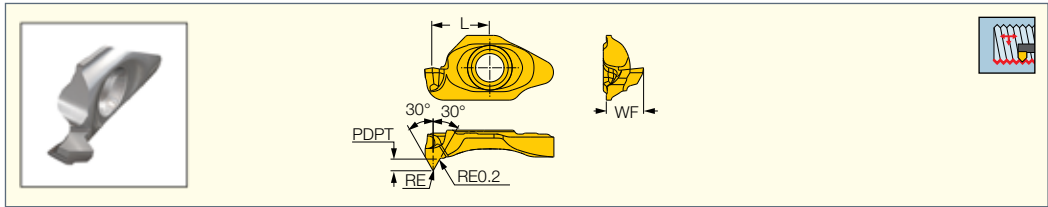

Designation	Dimensions							IC908
	PDPT ⁽¹⁾	RE	L	WF	DMIN ⁽²⁾	TPN ⁽³⁾	TPX ⁽⁴⁾	
MITR 8-MT2-0.1	1.17	0.10	5.75	3.80	10.00	1.500	2.000	●
MITR 8-MT1-0.05	1.23	0.05	5.75	3.80	10.00	0.750	1.250	●

- (1) Cutting depth maximum
- (2) Minimum diameter
- (3) Thread pitch minimum (mm)
- (4) Thread pitch maximum (mm)

For tools, see pages: MIFHR (374)

CHAMGROOVE

MG
Internal Grooving, Turning
and Threading Bars

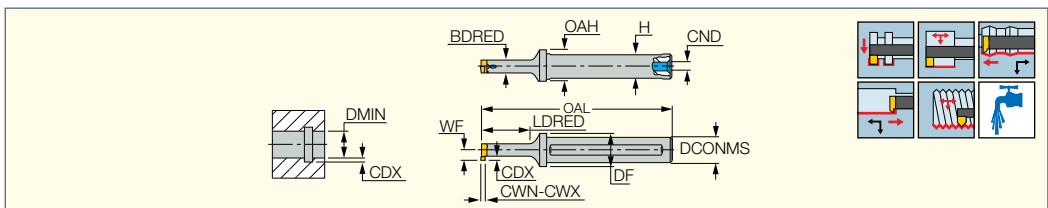

Designation	DCONMS	DMIN ⁽¹⁾	CDX ⁽²⁾	BDRED	OAL	LDRED	WF ⁽³⁾	H	CWN ⁽⁴⁾	CWX ⁽⁵⁾	OAH	DF	CND	Insert		
MG 12-08C16	12.00	8.00	1.50	6.00	92.00	16.0	4.80	11.0	0.50	3.00	16.3	18.00	6.0	GIQR/L 8	SR 76-1499	T-8/5
MG 12-08C23	12.00	8.00	1.50	6.00	92.00	23.0	4.80	11.0	0.50	3.00	16.3	18.00	6.0	GIQR/L 8	SR 76-1499	T-8/5
MG 12-11C25	12.00	11.00	2.30	8.00	92.50	25.0	6.70	11.0	0.50	3.00	16.3	18.00	6.0	GIQR/L 11	SR M3.5-08134	T-9/5

- The same tool applies on right and left machining
- (1) Check according to specific insert data
- (2) Check according to specific insert data
- (3) Cutting edge radius on rotating tool
- (4) Minimum cutting width
- (5) Maximum cutting width

For inserts, see pages: GIQR/L 8 (376) • GIQR/L 8-R (376) • GIQR/L 11 (377) • GIQR/L 11-R (377) • GIQR/L 11-15 (378) • GIQR/L 11-15-R (378) • GIQR/L-A18 (378) • GIQR/L-B18 (379) • GIQR/L-MT (379) • GIQR/L-WT (379)

CHAMGROOVE

MGCH
Solid Carbide Bars for
Internal Grooving, Turning
and Threading, Dmin 8 mm

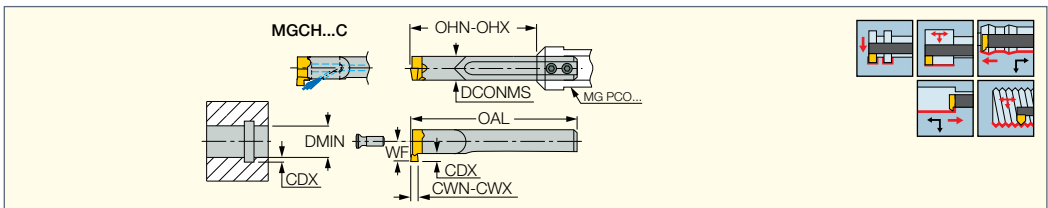

Designation	DMIN ⁽¹⁾	CDX ⁽²⁾	DCONMS	OAL	OHN ⁽³⁾	OHX ⁽⁴⁾	WF	CWN ⁽⁵⁾	CWX ⁽⁶⁾	CSP ⁽⁷⁾	Insert		
MGCH 06	8.00	1.50	6.00	62.00	16.0	42.0	4.80	0.50	4.00	0	GIQR/L 8	SR 76-1499	T-8/5
MGCH 06C	8.00	1.50	6.00	62.00	16.0	42.0	4.80	0.50	4.00	1	GIQR/L 8	SR 76-1499	T-8/5
MGCH 06-L100	8.00	1.50	6.00	100.00	16.0	80.0	4.80	0.50	4.00	0	GIQR/L 8	SR 76-1499	T-8/5
MGCH 08	- (8)	- (9)	8.00	76.00	20.0	56.0	- (10)	0.50	5.00	0	GIQR/L 11/11-15	SR M3.5-08134	T-9/5
MGCH 08C	- (8)	- (9)	8.00	76.00	20.0	56.0	- (10)	0.50	5.00	1	GIQR/L 11/11-15	SR M3.5-08134	T-9/5
MGCH 08-L125	- (8)	- (9)	8.00	125.00	20.0	105.0	- (10)	0.50	5.00	0	GIQR/L 11/11-15	SR M3.5-08134	T-9/5

- The same tool applies on right and left machining .
- (1) Check according to specific insert data
- (2) Check according to specific insert data
- (3) Minimum overhang
- (4) Maximum overhang
- (5) Minimum cutting width
- (6) Maximum cutting width
- (7) 0 - Without coolant supply, 1 - With coolant supply
- (8) DMIN=11 mm for GIQR 11, DMIN=15 mm for GIQR 11-15
- (9) CDX=2.30 for GIQR 11, CDX=6.3 for GIQR 11-15

(10) WF=6.70 mm for GIQR 11, WF=10.6 mm for GIQR 11-15

For inserts, see pages: GIQR/L 8 (376) • GIQR/L 8-R (376) • GIQR/L 11 (377) • GIQR/L 11-R (377) • GIQR/L 11-15 (378) • GIQR/L 11-15-R (378) • GIQR/L-A18 (378) • GIQR/L-B18 (379) • GIQR/L-MT (379) • GIQR/L-WT (379)

For holders, see pages: PICCO/MG PCO (holder) (360) • SBB (106)

CHAMGROOVE

GIQR/L 8

Precision Ground Single-Ended Inserts for Internal Grooving and Turning

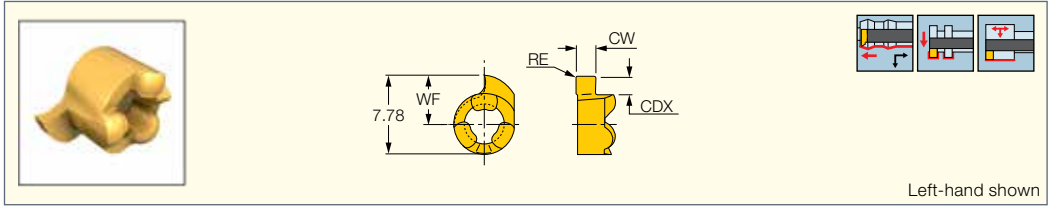

Designation	Dimensions							IC528	Recommended Machining Data		
	CW	RE	CWTOL ⁽²⁾	RETOL ⁽³⁾	CDX	DMIN	WF		a _p (mm)	f turn (mm/rev)	f groove (mm/rev)
GIQR/L 8-0.50-0.00 ⁽¹⁾	0.50	0.00	0.02	0.030	0.70	8.00	4.80	●	-	-	0.01-0.03
GIQR/L 8-0.75-0.00 ⁽¹⁾	0.75	0.00	0.02	0.030	1.20	8.00	4.80	●	-	-	0.01-0.03
GIQR/L 8-0.85-0.00 ⁽¹⁾	0.85	0.00	0.02	0.030	1.20	8.00	4.80	●	-	-	0.01-0.03
GIQR/L 8-0.95-0.00 ⁽¹⁾	0.95	0.00	0.02	0.030	1.50	8.00	4.80	●	-	-	0.01-0.03
GIQR/L 8-1.00-0.00 ⁽¹⁾	1.00	0.00	0.02	0.030	1.50	8.00	4.80	●	-	-	0.01-0.03
GIQR/L 8-1.04-0.05 ⁽¹⁾	1.04	0.05	0.02	0.030	1.50	8.00	4.80	●	-	-	0.01-0.03
GIQR/L 8-1.20-0.05 ⁽¹⁾	1.20	0.05	0.02	0.030	1.50	8.00	4.80	●	-	-	0.01-0.03
GIQR/L 8-1.40-0.05 ⁽¹⁾	1.40	0.05	0.02	0.030	1.50	8.00	4.80	●	-	-	0.01-0.03
GIQR/L 8-1.47-0.05 ⁽¹⁾	1.47	0.05	0.02	0.030	1.50	8.00	4.80	●	-	-	0.01-0.03
GIQR/L 8-1.50-0.05 ⁽¹⁾	1.50	0.05	0.02	0.030	1.50	8.00	4.80	●	-	-	0.01-0.03
GIQR/L 8-1.70-0.10	1.70	0.10	0.02	0.030	1.50	8.00	4.80	●	0.12-0.68	0.02-0.05	0.01-0.03
GIQR/L 8-1.96-0.10	1.96	0.10	0.02	0.030	1.50	8.00	4.80	●	0.12-0.78	0.02-0.05	0.01-0.03
GIQR/L 8-2.00-0.10	2.00	0.10	0.02	0.030	1.50	8.00	4.80	●	0.12-0.80	0.02-0.05	0.01-0.03
GIQR/L 8-2.22-0.10	2.22	0.10	0.02	0.030	1.50	8.00	4.80	●	0.12-0.88	0.02-0.05	0.01-0.03
GIQR/L 8-2.50-0.20	2.50	0.20	0.02	0.030	1.50	8.00	4.80	●	0.24-1.00	0.02-0.05	0.01-0.03
GIQR/L 8-3.00-0.20	3.00	0.20	0.02	0.030	1.50	8.00	4.80	●	0.24-1.20	0.02-0.05	0.01-0.03
GIQR 8-3.18-0.20	3.18	0.20	0.02	0.030	1.50	8.00	4.80	●	0.24-1.27	0.02-0.05	0.01-0.03
GIQR 8-3.50-0.20	3.50	0.20	0.02	0.030	1.50	8.00	4.80	●	0.24-1.40	0.02-0.05	0.01-0.03
GIQR 8-4.00-0.20	4.00	0.20	0.02	0.030	1.50	8.00	4.80	●	0.24-1.60	0.02-0.05	0.01-0.03

• According to retaining rings standard DIN 471/472. • Can be used for groove milling by circular interpolation • For cutting speed recommendations, see pages 380-395

⁽¹⁾ For grooving only

⁽²⁾ Cutting width tolerance (+/-)

⁽³⁾ Corner radius tolerance (+/-)

For tools, see pages: MG (375) • MGCH (375)

CHAMGROOVE

GIQR/L 8-R

Precision Ground Single-Ended Full Radius Inserts for Internal Grooving and Profiling

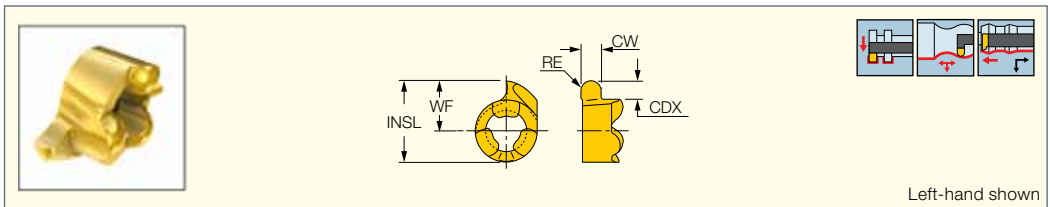

Designation	Dimensions								IC528	Recommended Machining Data		
	CW	RE	CWTOL ⁽¹⁾	RETOL ⁽²⁾	CDX	DMIN	WF	INSL		a _p (mm)	f turn (mm/rev)	f groove (mm/rev)
GIQR/L 8-1.20-R060	1.20	0.60	0.02	0.030	1.50	8.00	4.80	7.78	●	0.30-0.60	0.02-0.05	0.01-0.03
GIQR/L 8-2.00-R100	2.00	1.00	0.02	0.030	1.50	8.00	4.80	7.78	●	0.50-1.00	0.02-0.05	0.01-0.03
GIQR 8-3.00-R150	3.00	1.50	0.02	0.030	1.50	8.00	4.80	7.78	●	0.70-1.50	0.02-0.05	0.01-0.03

• Comply to retaining rings DIN 471/472 • Can be used for groove milling by circular interpolation • For cutting speed recommendations, see pages 380-395

⁽¹⁾ Cutting width tolerance (+/-)

⁽²⁾ Corner radius tolerance (+/-)

For tools, see pages: MG (375) • MGCH (375)



CHAMGROOVE

GIQR/L 11

Precision Ground Single-Ended Inserts for Internal Grooving and Turning, Dmin 11 mm

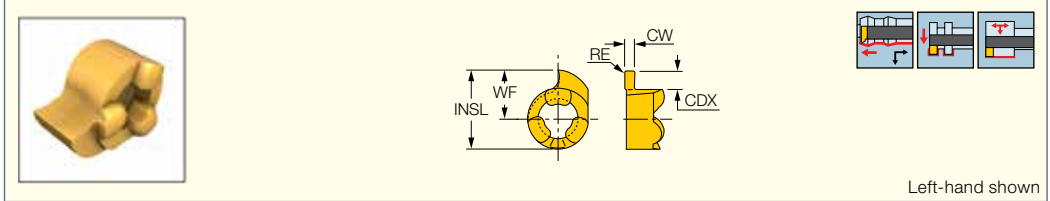

Designation	Dimensions								IC528	Recommended Machining Data		
	CW	RE	CWTOL ⁽²⁾	RETOL ⁽³⁾	CDX	DMIN	INSL	WF		a _p (mm)	f turn (mm/rev)	f groove (mm/rev)
GIQR/L 11-0.50-0.00 ⁽¹⁾	0.50	0.00	0.02	0.030	1.50	11.00	10.68	6.70	●	-	-	0.01-0.03
GIQR/L 11-0.75-0.00 ⁽¹⁾	0.75	0.00	0.02	0.030	1.50	11.00	10.68	6.70	●	-	-	0.01-0.03
GIQR/L 11-0.85-0.00 ⁽¹⁾	0.85	0.00	0.02	0.030	1.50	11.00	10.68	6.70	●	-	-	0.01-0.03
GIQR/L 11-0.95-0.00 ⁽¹⁾	0.95	0.00	0.02	0.030	1.80	11.00	10.68	6.70	●	-	-	0.01-0.03
GIQR/L 11-1.04-0.05 ⁽¹⁾	1.04	0.05	0.02	0.030	2.00	11.00	10.68	6.70	●	-	-	0.01-0.03
GIQR/L 11-1.20-0.05 ⁽¹⁾	1.20	0.05	0.02	0.030	2.30	11.00	10.68	6.70	●	-	-	0.01-0.03
GIQR/L 11-1.40-0.05 ⁽¹⁾	1.40	0.05	0.02	0.030	2.30	11.00	10.68	6.70	●	-	-	0.01-0.03
GIQR/L 11-1.50-0.05 ⁽¹⁾	1.50	0.05	0.02	0.030	2.30	11.00	10.68	6.70	●	-	-	0.01-0.03
GIQR/L 11-1.70-0.05 ⁽¹⁾	1.70	0.05	0.02	0.030	2.30	11.00	10.68	6.70	●	-	-	0.01-0.03
GIQR/L 11-1.96-0.10 ⁽¹⁾	1.96	0.10	0.02	0.030	2.30	11.00	10.68	6.70	●	-	-	0.01-0.03
GIQR/L 11-2.00-0.10 ⁽¹⁾	2.00	0.10	0.02	0.030	2.30	11.00	10.68	6.70	●	-	-	0.01-0.03
GIQR/L 11-2.22-0.10	2.22	0.10	0.02	0.030	2.30	11.00	10.68	6.70	●	0.12-0.88	0.03-0.07	0.02-0.05
GIQR/L 11-2.39-0.15	2.39	0.15	0.02	0.030	2.30	11.00	10.68	6.70	●	0.18-0.95	0.03-0.07	0.02-0.05
GIQR/L 11-2.47-0.20	2.47	0.20	0.02	0.030	2.30	11.00	10.68	6.70	●	0.24-0.98	0.03-0.07	0.02-0.05
GIQR/L 11-2.50-0.20	2.50	0.20	0.02	0.030	2.30	11.00	10.68	6.70	●	0.24-1.00	0.03-0.07	0.02-0.05
GIQR/L 11-2.70-0.20	2.70	0.20	0.02	0.030	2.30	11.00	10.68	6.70	●	0.24-1.08	0.03-0.07	0.02-0.05
GIQR/L 11-3.00-0.20	3.00	0.20	0.02	0.030	2.30	11.00	10.68	6.70	●	0.24-1.20	0.03-0.07	0.02-0.05
GIQR 11-3.18-0.20	3.18	0.20	0.02	0.030	2.30	11.00	10.68	6.70	●	0.24-1.27	0.03-0.07	0.02-0.05
GIQR 11-4.00-0.20	4.00	0.20	0.02	0.030	2.30	11.00	10.68	6.70	●	0.24-1.60	0.03-0.07	0.02-0.05
GIQR 11-5.00-0.20	5.00	0.20	0.02	0.030	2.30	11.00	10.68	6.70	●	0.24-2.00	0.03-0.07	0.02-0.05

• Comply to retaining rings DIN 471/472 • Can be used for groove milling by circular interpolation • For cutting speed recommendations, see pages 380-395

⁽¹⁾ For grooving only

⁽²⁾ Cutting width tolerance (+/-)

⁽³⁾ Corner radius tolerance (+/-)

For tools, see pages: MG (375) • MGCH (375)

CHAMGROOVE

GIQR/L 11-R

Precision Ground Single-Ended Full Radius Inserts for Internal Grooving and Profiling

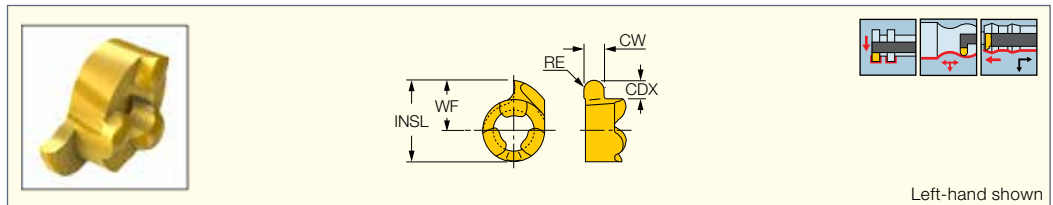

Designation	Dimensions								IC528	Recommended Machining Data		
	CW	RE	CWTOL ⁽¹⁾	RETOL ⁽²⁾	CDX	DMIN	WF	INSL		a _p (mm)	f turn (mm/rev)	f groove (mm/rev)
GIQR/L 11-1.20-R060	1.20	0.60	0.02	0.030	2.30	11.00	6.70	10.68	●	0.30-0.60	0.02-0.05	0.01-0.03
GIQR/L 11-1.80-R090	1.80	0.90	0.02	0.030	2.30	11.00	6.70	10.68	●	0.40-0.90	0.02-0.05	0.01-0.03
GIQR/L 11-2.00-R100	2.00	1.00	0.02	0.030	2.30	11.00	6.70	10.68	●	0.50-1.00	0.02-0.05	0.01-0.03
GIQR/L 11-3.00-R150	3.00	1.50	0.02	0.030	2.30	11.00	6.70	10.68	●	0.70-1.50	0.02-0.05	0.01-0.03
GIQR 11-4.00-R200	4.00	2.00	0.02	0.030	2.30	11.00	6.70	10.68	●	1.00-2.00	0.02-0.05	0.01-0.03

• Comply to retaining rings DIN 471/472 • Can be used for groove milling by circular interpolation • For cutting speed recommendations, see pages 380-395

⁽¹⁾ Cutting width tolerance (+/-)

⁽²⁾ Corner radius tolerance (+/-)

For tools, see pages: MG (375) • MGCH (375)



CHAMGROOVE

GIQR/L 11-15

Precision Ground Single-Ended Inserts for Internal Deep Grooving and Turning

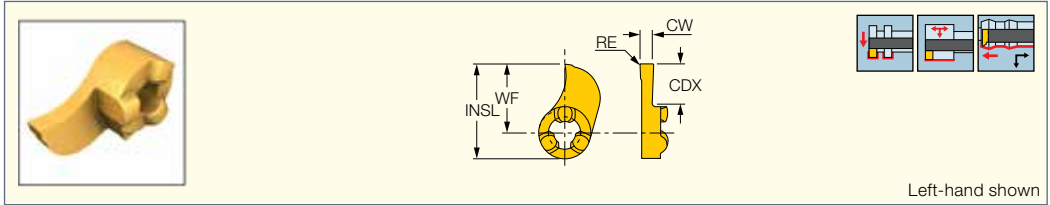

Left-hand shown

Designation	Dimensions									IC528	Recommended Machining Data		
	CW	RE	CWTOL ⁽¹⁾	RETOL ⁽²⁾	CDX	DMIN	INSL	WF	SR		a _p (mm)	f turn (mm/rev)	f groove (mm/rev)
GIQR/L 11-15-1.50-0.05	1.50	0.05	0.02	0.030	6.30	15.00	14.60	10.60	SR M3.5-08134	●	0.10-0.40	0.02-0.05	0.02-0.06
GIQR/L 11-15-2.00-0.10	2.00	0.10	0.02	0.030	6.30	15.00	14.60	10.60	SR M3.5-08134	●	0.15-0.50	0.02-0.05	0.02-0.06
GIQR/L 11-15-2.50-0.20	2.50	0.20	0.02	0.030	6.30	15.00	14.60	10.60	SR M3.5-08134	●	0.25-0.65	0.02-0.05	0.02-0.06
GIQR/L 11-15-3.00-0.20	3.00	0.20	0.02	0.030	6.30	15.00	14.60	10.60	SR M3.5-08134	●	0.25-0.75	0.02-0.05	0.02-0.06

• Comply to retaining rings DIN 471/472 • Can be used for groove milling by circular interpolation • For cutting speed recommendations, see pages 380-395

⁽¹⁾ Cutting width tolerance (+/-)

⁽²⁾ Corner radius tolerance (+/-)

For tools, see pages: MG (375) • MGCH (375)

CHAMGROOVE

GIQR/L 11-15-R

Precision Ground Single-Ended Full Radius Inserts for Deep Internal Grooving and Profiling

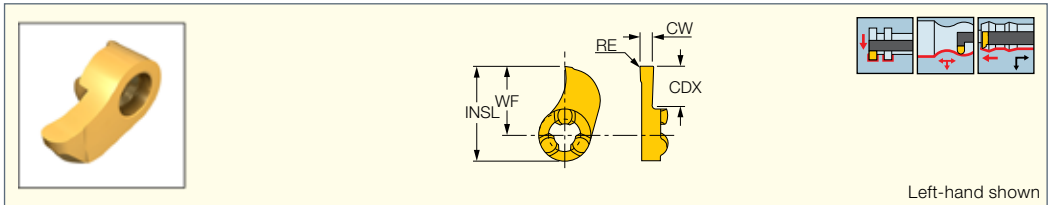

Left-hand shown

Designation	Dimensions									IC528	Recommended Machining Data		
	CW	RE	CWTOL ⁽¹⁾	RETOL ⁽²⁾	CDX	DMIN	WF	INSL	SR		a _p (mm)	f turn (mm/rev)	f groove (mm/rev)
GIQR/L 11-15-2.00-R100	2.00	1.00	0.02	0.030	6.30	15.00	10.60	14.60	SR M3.5-08134	●	0.00-0.50	0.02-0.05	0.02-0.06
GIQR/L 11-15-2.50-R125	2.50	1.25	0.02	0.030	6.30	15.00	10.60	14.60	SR M3.5-08134	●	0.00-0.65	0.02-0.05	0.02-0.06
GIQR/L 11-15-3.00-R150	3.00	1.50	0.02	0.030	6.30	15.00	10.60	14.60	SR M3.5-08134	●	0.00-0.75	0.02-0.05	0.02-0.06

• Comply to retaining rings DIN 471/472 • Can be used for groove milling by circular interpolation • For cutting speed recommendations, see pages 380-395

⁽¹⁾ Cutting width tolerance (+/-)

⁽²⁾ Corner radius tolerance (+/-)

For tools, see pages: MG (375) • MGCH (375)

CHAMGROOVE

GIQR/L-A18

Internal Boring and Profiling Inserts

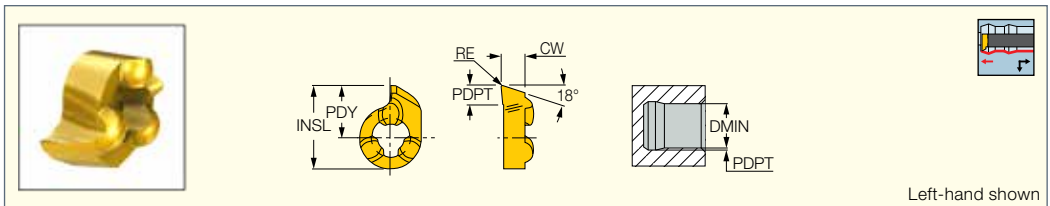

Left-hand shown

Designation	Dimensions						IC528	Recommended Machining Data		
	DMIN	CW	RE	PDPT	INSL	PDY		a _p (mm)	f (mm/rev)	f groove (mm/rev)
GIQR/L 8-A18-0.15	7.80	3.00	0.15	1.60	7.60	4.60	●	0.02-1.30	0.02-0.05	0.01-0.03
GIQR/L 11-A18-0.15	11.00	3.00	0.15	2.50	10.70	6.70	●	0.02-2.20	0.02-0.05	0.01-0.03

• For cutting speed recommendations, see pages 380-395

For tools, see pages: MG (375) • MGCH (375)

CHAMGROOVE

GIQR/L-B18
Internal Back Boring
and Profiling Inserts

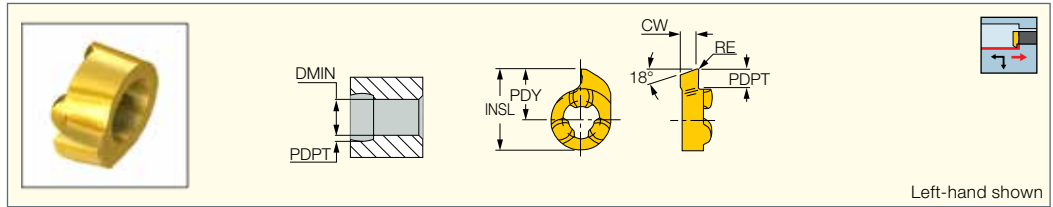

Left-hand shown

Designation	Dimensions						IC528	Recommended Machining Data	
	DMIN	CW	RE	PDPT	PDY	INSL		a_p (mm)	f (mm/rev)
GIQR/L 8-B18-0.15	7.80	2.50	0.15	1.30	4.60	7.60	●	0.02-1.00	0.02-0.05
GIQR/L 11-B18-0.15	11.00	2.50	0.15	2.30	6.70	10.70	●	0.02-2.00	0.02-0.05

• For cutting speed recommendations, see pages 380-395

For tools, see pages: MG (375) • MGCH (375)

ISCARTHREAD

CHAMGROOVE

GIQR/L-MT
Internal Threading Inserts with a
60° Partial Profile for Threading
in 8 mm and Larger Holes

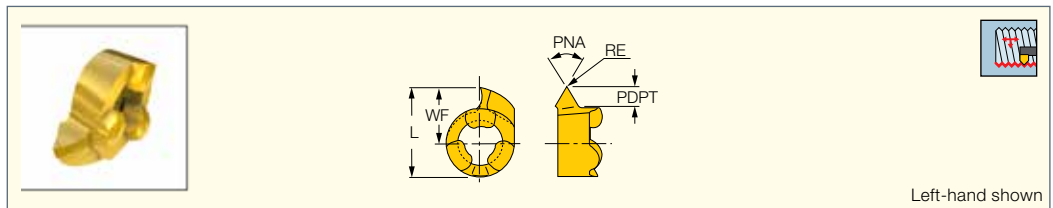

Left-hand shown

Designation	Dimensions								IC528
	L	RE	PNA	PDPT ⁽¹⁾	WF	DMIN ⁽²⁾	TPN ⁽³⁾	TPIX ⁽⁴⁾	
GIQR/L 8-MT-0.05	7.78	0.05	60.0	1.50	4.80	8.00	0.900	28.00	●
GIQR/L 11-MT-0.05	10.68	0.05	60.0	2.00	6.70	11.00	0.900	28.00	●

• Can be used for thread milling by circular interpolation • Pitch max 0.19xD • D-diameter of thread • For cutting speed recommendations, see pages 380-395

⁽¹⁾ Cutting depth maximum

⁽²⁾ Minimum diameter

⁽³⁾ Thread pitch minimum (mm)

⁽⁴⁾ Threads per inch maximum

For tools, see pages: MG (375) • MGCH (375)

ISCARTHREAD

CHAMGROOVE

GIQR/L-WT
Internal Inserts with Whitworth
Partial Profile for Threading
in 8 mm and Larger Holes

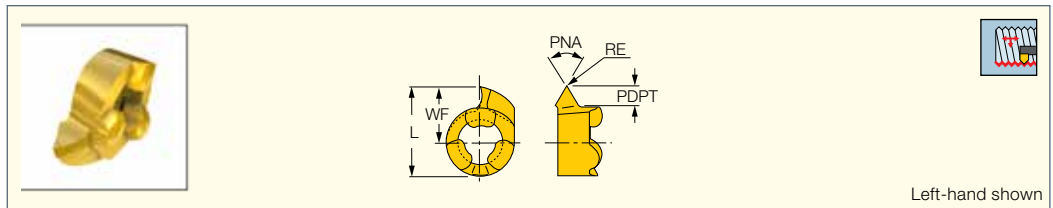

Left-hand shown

Designation	Dimensions								IC528
	L	RE	PNA	PDPT	WF	DMIN	TPN ⁽¹⁾	TPIX ⁽²⁾	
GIQR/L 8-WT-0.05	7.78	0.05	55	1.50	4.80	8.00	0.500	50.00	●
GIQR/L 11-WT-0.05	10.68	0.05	55	2.00	6.70	11.00	0.500	50.00	●

• Can be used for thread milling by circular interpolation • TPI min D/5.9 • D-diameter of thread (pitch max<=W) • For cutting speed recommendations, see pages 380-395

⁽¹⁾ Cutting depth maximum

⁽²⁾ Thread pitch minimum (mm)

For tools, see pages: MG (375) • MGCH (375)

Groove-Turn Cutting Speed Recommendations

ISO	Material	Condition	Tensile Strength [N/mm ²]	Hardness HB	Material No. ⁽¹⁾	
P	Non-alloy steel and cast steel, free cutting steel	< 0.25 %C	Annealed	420	125	1
		>= 0.25 %C	Annealed	650	190	2
		< 0.55 %C	Quenched and tempered	850	250	3
		>= 0.55 %C	Annealed	750	220	4
		>= 0.55 %C	Quenched and tempered	1000	300	5
	Low alloy steel and cast steel (less than 5% all elements)	Annealed		600	200	6
		Quenched and tempered		930	275	7
				1000	300	8
	High alloy steel, cast steel, tool steel	Annealed		680	200	10
		Quenched and tempered		1100	325	11
	P	Stainless steel and cast steel	Ferritic/martensitic	680	200	12
Martensitic			820	240	13	
M	Stainless steel	Austenitic	600	180	14	
K	Grey cast iron (GG)	Pearlitic/ferritic		180	15	
		Pearlitic/martensitic		260	16	
	Ductile cast iron (nodular) (GGG)	Ferritic		160	17	
		Pearlitic		250	18	
	Malleable cast iron	Ferritic		130	19	
		Pearlitic		230	20	
N	Aluminum-wrought alloy	Not cureable		60	21	
		Cured		100	22	
	Aluminum-cast, alloyed	<=12% Si	Not cureable		75	23
			Cured		90	24
		>12% Si	High temperature		130	25
	Copper alloys	>1% Pb	Free cutting		110	26
			Brass		90	27
			Electrolytic copper		100	28
	Non-metallic	Duroplastics, fiber plastics				29
		Hard rubber				30
S	High temp. alloys	Fe Baswd	Annealed		200	31
			Cured		280	32
		Ni or Co based	Annealed		250	33
			Cured		350	34
			Cast		320	35
	Titanium and Ti alloys			RM 400		36
				Alpha+beta alloys cured	RM 1050	37
H	Hardened steel	Hardened		55 HRc	38	
		Hardened		60 HRc	39	
	Chilled cast iron	Cast		400	40	
	Cast iron	Hardened		55 HRc	41	

⁽¹⁾ For material groups, see pages 688-723

Material No.	IC20N	IC8250	IC807	IC808	IC908	IC354	IC830	IC228/328/528		
1	225 - 335	210 - 315	160 - 240	145 - 220	140-210	110 - 170	105 - 155	100 - 145		
2	210 - 290	195 - 270	150 - 205	135 - 190	130-180	105 - 145	95 - 135	90 - 125		
3	160 - 240	150 - 225	115 - 170	105 - 155	100-150	80 - 120	75 - 110	70 - 105		
4	175 - 270	165 - 255	125 - 195	115 - 180	110-170	90 - 135	80 - 125	75 - 120		
5	145 - 225	135 - 210	105 - 160	95 - 145	90-140	70 - 110	65 - 105	65 - 100		
6	175 - 270	165 - 255	125 - 195	115 - 180	110-170	90 - 135	80 - 125	75 - 120		
7	145 - 240	135 - 225	105 - 170	95 - 155	90-150	70 - 120	65 - 110	65 - 105		
8	145 - 225	135 - 210	105 - 160	95 - 145	90-140	70 - 110	65 - 105	65 - 100		
9	130 - 210	120 - 195	90 - 150	85 - 135	80-130	65 - 105	60 - 95	55 - 90		
10	210 - 290	195 - 270	150 - 205	135 - 190	130-180	105 - 145	95 - 135	90 - 125		
11	130 - 210	120 - 195	90 - 150	85 - 135	80-130	65 - 105	60 - 95	55 - 90		

	IC20N	IC806	IC907/807	IC8250	IC808	IC908	IC320	IC830	IC354	
12	180 - 320	130 - 240	125 - 230	120 - 220	115 - 210	110-200	100 - 180	80 - 150	90 - 160	
13	160 - 300	120 - 230	115 - 220	110 - 210	105 - 200	100-190	90 - 170	75 - 140	80 - 150	

	IC20N	IC806	IC907/807	IC8250	IC808	IC908	IC320	IC830	IC354	
14	140 - 270	110 - 205	105 - 195	100 - 185	95 - 180	90-170	80 - 155	65 - 125	70 - 135	

	IC5010	IC418	IC428	IC8250	IC907/807	IC908/808				
15	165 - 295	140 - 255	150-270	135 - 245	105 - 190	95 - 175				
16	145 - 210	125 - 180	130-190	115 - 170	90 - 135	85 - 125				
17	155 - 255	135 - 220	140-230	125 - 205	100 - 160	90 - 150				
18	120 - 200	105 - 170	110-180	100 - 160	75 - 125	70 - 115				
19	185 - 310	160 - 265	170-280	155 - 250	120 - 195	110 - 180				
20	155 - 255	135 - 220	140-230	125 - 205	100 - 160	90 - 150				

	ID5	IC04	IC807	IC20	IC04	IC07	IC08			
21	400-2500	460 - 1380	440 - 1320	400-1200	460 - 1380	440 - 1320	320 - 960			
22	400-2500	345 - 1150	330 - 1100	300-1000	345 - 1150	330 - 1100	240 - 800			
23	400-2500	345 - 1150	330 - 1100	300-1000	345 - 1150	330 - 1100	240 - 800			
24	400-2500	230 - 690	220 - 660	200-600	230 - 690	220 - 660	160 - 480			
25	300-1500	230 - 460	220 - 440	200-400	230 - 460	220 - 440	160 - 320			
26	300-1000	230 - 460	220 - 440	200-400	230 - 460	220 - 440	160 - 320			
27	300-800	170 - 345	165 - 330	150-300	170 - 345	165 - 330	120 - 240			
28	300-800	115 - 230	110 - 220	100-200	115 - 230	110 - 220	80 - 160			
29	150-600	55 - 230	55 - 220	50-200	55 - 230	55 - 220	40 - 160			
30										

No.	IC804	IC806	IC807	IC907	IC908	IC808	IC04	IC07	IC20	IC08
31	60 - 95	50 - 80	50 - 80	45 - 75	40-65	40 - 70	30 - 50	30 - 45	25 - 40	25 - 40
32	45 - 65	35 - 55	35 - 55	35 - 50	30-45	30 - 45	25 - 35	20 - 30	20 - 30	20 - 25
33	45 - 65	35 - 55	35 - 55	35 - 50	30-45	30 - 45	25 - 35	20 - 30	20 - 30	20 - 25
34	35 - 60	30 - 50	30 - 50	30 - 45	25-40	25 - 40	20 - 30	15 - 30	15 - 25	15 - 25
35	30 - 45	25 - 35	25 - 35	25 - 35	20-30	20 - 30	15 - 25	15 - 20	15 - 20	10 - 20
36	150 - 255	125 - 210	120 - 205	115 - 195	100-170	105 - 180	80 - 135	70 - 120	65 - 110	60 - 100
37	50 - 65	45 - 60	40 - 50	40 - 50	35-45	35 - 45	50 - 65	40 - 55	40 - 50	35 - 45

No.	IB10H	IB50	IB20H	IC807	IC907	IC808	IC908			
38	100-155	90-140	80-125	35-45	30-40	30-40	25-35			
39	90-135	80-120	75-110	30-40	25-35	25-35	20-30			
40	110-175	100-160	90-145	45-65	40-60	40-60	30-50			
41	100-135	90-120	80-110	40-50	35-45	35-45	30-40			

Grades	ISO	Coating Layers
IC228	P30-P45 M25-M45	TiN
IC528	P30-P45 M30-M40	TiN TiCN
S.T. IC804	S05-S15	TiAlN AlTiN
S.T. IC806	S10-S20 M05-M15	TiAlN AlTiN
S.T. IC807	P10-P20 M05-M15 S10-S20 K15-K30 H05-H15	TiN TiAlN
S.T. IC808	P15-P30 M20-M30 K20-K40 S15-S30 H20-H30	TiN TiAlN
S.T. IC830	P30-P45 M25-M45	TiN TiAlN
IC907	P10-P20 M05-M15 S10-S20 K15-K30 H05-H15	TiAlN
IC908	P15-P30 M20-M30 K20-K40 S15-S30 H20-H30	TiAlN
IC1007	P10-P20 M05-M15 S10-S20 K15-K30 H05-H15	TiN TiAlN
IC1008	P15-P30 M20-M30 K20-K40 S15-S30 H20-H30	TiN TiAlN
IC418	K10-K25	Al ₂ O ₃ TiC
IC428	K05-K20 H15-H25 P05-P15	Al ₂ O ₃ TiC
S.T. IC5010	K10-K25	TiN Al ₂ O ₃ TiCN
S.T. IC8250	P10-P35 M15-M25	TiN Al ₂ O ₃ TiCN

S.T. SUMO TEC ■ PVD COATED ■ CVD COATED

Recommended Applications

TiN PVD coated grade on tough substrate.
The grade is recommended for steels and stainless steels at low to medium cutting speeds.

TiCN + TiN PVD coated grade on very tough substrate for grooving and turning applications at low to medium cutting speeds on steels and stainless steel. The grade can function also at unstable conditions.

A very hard submicron substrate with **AlTiN + TiAlN PVD** coating and a special **SUMO TEC** surface treatment. Suitable for semi finishing and finishing operations of high temperature alloys at medium to high cutting speeds.

A hard submicron substrate with **AlTiN + TiAlN PVD** coating and a special **SUMO TEC** surface treatment. First choice for grooving and turning of high temperature alloys. Suitable also for titanium alloys, at medium to relatively high cutting speeds.

A hard submicron substrate with **TiAlN + TiN PVD** coating and a special **SUMO TEC** surface treatment. Suitable for turning and grooving of high temperature alloys, austenitic stainless steel and hard steels at low to medium cutting speeds.

A tough submicron substrate with **TiAlN + TiN PVD** coating and a special **SUMO TEC** surface treatment. Recommended for grooving and turning on large variety of materials as well as high temperature alloys, stainless steel and hard steels at low to medium cutting speeds.

TiAlN + TiN PVD coated grade with a special **SUMO TEC** surface treatment on very tough substrate for grooving and turning of steel and stainless steel at low to medium speeds and medium to high feeds. The grade is recommended for interrupted cut and machining at unstable conditions.

A very hard submicron substrate with **TiAlN PVD** coating. Suitable for grooving and turning of steel, alloy steels, austenitic stainless steel, high temperature alloys and hard steels at medium cutting speeds.

A tough submicron substrate with **TiAlN PVD** coating. Recommended for general use in grooving and turning operations on large variety of materials as well as steel, alloy steels, stainless steel high temperature alloys at low to medium cutting speeds.

A hard submicron substrate with **TiAlN + TiN PVD** coating, suitable for grooving and turning of high temperature alloys, austenitic stainless steel and hard steels at low to medium speeds.

A tough submicron substrate with **TiAlN + TiN PVD** coating. Recommended for general use in grooving and turning operations on large variety of materials as well as high temperature alloys, stainless steel and hard steels at low to medium cutting speeds.

A **TiC + Al₂O₃** multilayer **CVD** coated grade. Used for turning and grooving of grey and nodular cast iron at medium to high cutting speeds. Can be used for interrupted cut and heavy machining.

A **TiC + Al₂O₃** multilayer **CVD** coated grade. Used for turning and grooving of grey and nodular cast iron at medium to high cutting speeds.

A **TiCN + Al₂O₃** multilayer, **CVD** coated grade with a special **SUMO TEC** surface treatment. Used for machining of grey and nodular cast iron at medium to high cutting speeds.

A tough substrate with a cobalt enriched layer combined with **MTCVD TiCN** and a thick alpha **Al₂O₃ CVD** coating with a special **SUMO TEC** surface treatment. Recommended for general use machining of steels and martensitic stainless steel in a wide range of conditions, features high toughness and wear resistance.

Grades	ISO	Coating Layers
IC20N	P05-P25 M05-M15	
IC4	S05-S15 N01-N15	
IC07	S10-S25 N05-N20 M10-M20	
IC08	M15-M30 S15-S30 N10-N25	
IC20	N05-N25 S10-S20 K10-K20 H10-H20	
IB10H	H10	
IB20H	H20	
IB50	K01-K10 H01-H10	
ID5	N01-N10	

■ CERMET
 ■ UNCOATED
 ■ CBN
 ■ PCD

Recommended Applications

A hard cermet grade, used for grooving and turning applications. Recommended for steels at high cutting speeds and low feeds, provides excellent surface finish. Features improved wear resistance and prevents build-up edge.

A very hard uncoated submicron carbide grade. Used for machining titanium and high temperature alloys at medium to relatively high cutting speeds. Suitable also for aluminium and other nonferrous materials.

A hard uncoated submicron carbide grade. Used for machining titanium, high temperature alloys and aluminum alloys at medium to high cutting speeds.

A tough uncoated submicron carbide grade, used for steels, stainless steel and high temperature alloys at low cutting speeds.

An uncoated carbide grade. Used for turning and grooving of aluminum and other nonferrous materials at medium to high cutting speeds. Suitable also for high temperature and titanium alloys machining at low cutting speeds.

Extra fine grain **PCBN**, used for finish turning and grooving of hardened steels **45-65 HRc**.

A combination of coarse and fine grain **PCBN**, used for finish turning and grooving, continuous and interrupted cutting of hardened steels **45-65 HRc**.

A 50% **PCBN** grade, used for finish turning and grooving of hardened steel **45-65 HRc** and nodular cast iron in continuous cutting.

A **PCD** brazed tip, suitable for machining aluminum and other nonferrous materials at very high cutting speeds.

What is a GRIP Insert?

A grip insert is a grooving, groove-turn or parting insert that is clamped between 2 prisms.

Clamping a grip insert correctly in the holder is necessary for stable machining.

- 1 Ensure that the seat is clean of dirt and swarf.
- 2 In the first stage of clamping, ease the insert gently into place. Make sure that the prismatic surfaces match.
- 3 Always use the wrench supplied with the tool. Use reasonable force to the point of resistance for final clamping. The maximum recommended clamping torque is 1.5xd Nm or 15xd Kgf x cm. d=clamping screw dia. in mm.

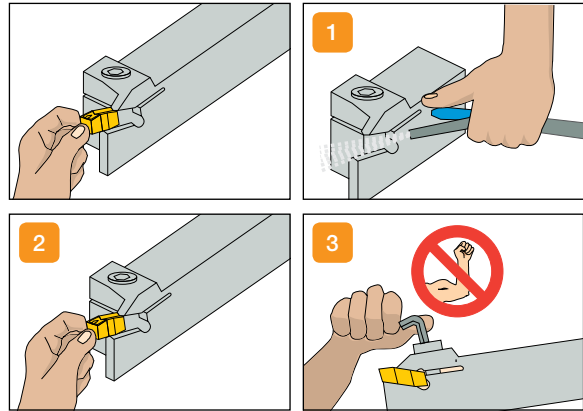

It is very important not to overtighten a grip insert, even though you may get the impression that the insert is more secure. When overtightened, the insert doesn't clamp into its correct and carefully designed clamping points, and therefore, is less stable.

Positioning the Tool on the Turret

Successful machining can be achieved only if the tool is properly positioned on the turret.

The following sequence should be followed:

- Position the grip holder perpendicular to the workpiece; deviation may be 0.10/100 mm along the holder
- Check to ensure that the frontal cutting edge is aligned parallel to the workpiece



If the cutting edge is not parallel to the workpiece or is positioned as shown, the deflection during machining (in the indicated direction) will be too small and chatter may occur.

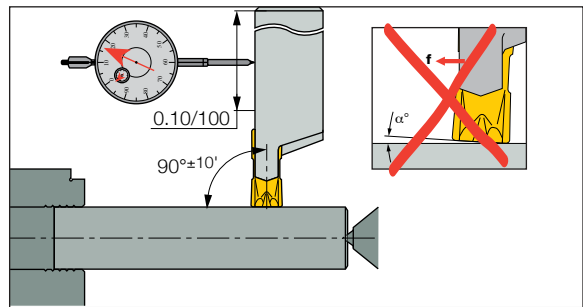

Principles of Turning with Groove-Turn Tools

The basic principle in turning with groove-turn tools is the deflection of the cutting tool, which results in a frontal clearance angle α° between the insert and the workpiece. The clearance angle α° is a function of the side cutting forces and is not constant, as is the case with ISO inserts. The deflection is influenced by the following factors:

- Feed **f**
- Depth of Cut **ap**
- Overhang of Insert Support **T**
- Width of Insert Support **A**
- Cutting Speed **Vc**
- Workpiece Material

When all of the above factors remain constant during turning, a high degree of accuracy with a tolerance up to ± 0.01 mm can be achieved.



If the conditions are too light (such as in a super finish operation), there may not be enough deflection and the clearance angle will be very small. This may result in chatter and vibration.

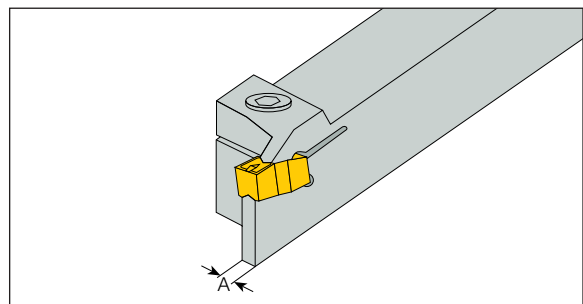
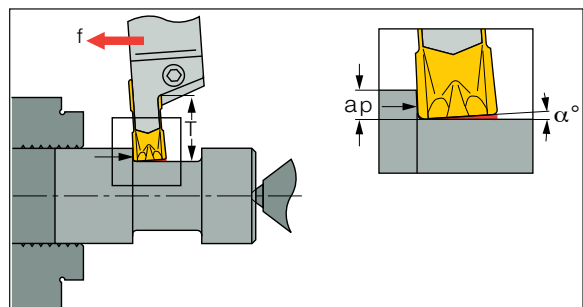

Cutting Conditions

Choosing the correct cutting conditions

Specific cutting conditions are listed in the catalog for every individual insert as shown below:

Example: GIMF 608 Utility Inserts for Grooving and Turning

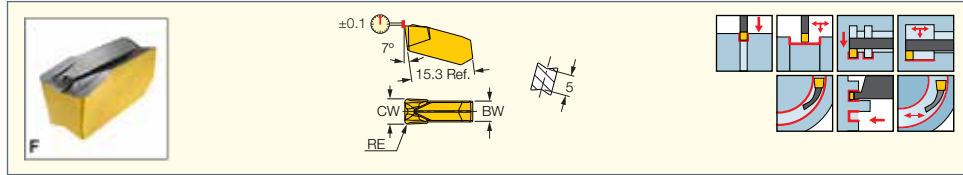

Designation	Dimensions			Tough ↔ Hard								Recommended Machining Data			
	W±0.05	R±0.05	M	IC830	IC8250	IC808	IC908	IC20	IC428	IC5010	IC907	IC806	a _p (mm)	f _{turn} (mm/rev)	f _{groove} (mm/rev)
GIMF 608	6.00	0.80	5.0	•	•	•		•		•		•	1.00-3.60	0.24-0.42	0.13-0.25
													Depth of cut	Turning feed	Grooving feed

Grades for Applications and Materials

- Carbide grades and cutting speeds:
- Cutting speed recommendations are derived from the type of workpiece material and choice of carbide grade

- Choose the carbide grade according to the chart below. For specific workpiece material and cutting speed recommendations, refer to pages 380-381

Material groups	ISO P		ISO M	ISO K	ISO N	ISO S	ISO H
	1-11 Steel	12-13 Stainless Steel Ferritic & Martensitic	14 Stainless Steel Austenitic & Duplex (Ferritic-Austenitic)	15-20 Cast Iron	21-28 Non-ferrous	31-37 High Temperature Alloys	38-41 Hard Steel & Cast Iron
<p>GROOVE TURN</p>	IC20N	IC807	IC807	IC5010	ID5	IC804 IC806	IB50
	IC807					IC907	
	IC808 (IC908) IC8250	IC808 (IC908)	IC808 (IC908)	IC428		IC807 IC07 IC20	IC807 IC808
				IC8250	IC20	IC908	
	IC830	IC830	IC830			IC08	

■ First choice

Machining Tips

Insert Width

Generally, the insert width should be as wide as possible as it contributes to its strength. However, there are additional considerations that should be taken into account in order to choose the correct width:

- Workpiece size and clamping stability:
A larger width means higher cutting forces during grooving. A width that is too large can cause deformation of the workpiece and/or vibration.
- When using a larger width, make sure your machine has enough power. (see page 393)
- Machining strategy:
Grooving in a correct sequence should also affect your choice. (see page 389)
- Required overhang:
A larger tool overhang will require a wider insert to maintain stability.
- The larger the insert, the wider the upper and lower jaws can be, therefore, higher forces are required to effect the necessary side deflection.
- If the depth of cut is small, the width of the insert should be proportionately smaller to guarantee the required deflection.

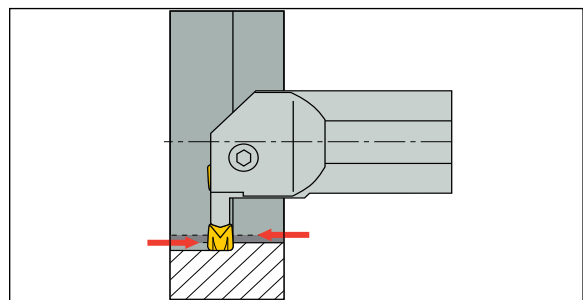
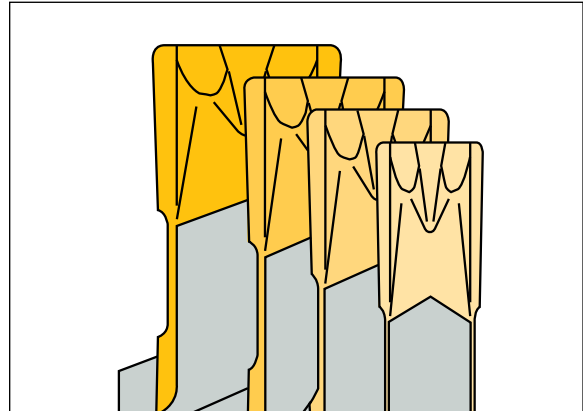

Efficient use of insert's corners:

Always try to evenly split machining between the two corners. This optimization will increase the insert's life.

Insert Radius

Choosing the insert radius for a particular application is a combination of many factors. The corner radius of the groove-turn insert influences the product shape and tool life.

- A larger radius in turning operations normally improves surface quality.
- An insert with a larger radius has a better distribution of the cutting load and of the generated heat. It is stronger and ensures longer tool life.
- Small radii on grip inserts result in increased side forces and side deflection, preventing instability, especially with small depths of cut and feed.
- The best radius to use is basically determined by the geometry and dimensions of the workpiece. The more securely the workpiece is fastened in the machine tool, the larger the radius may be.

- When the ratio of a workpiece's length compared to its diameter is large, inserts with smaller radii will prevent chatter.
- A larger corner radius enables machining at a larger feed rate.
- In profiling operations, inserts with larger corner radii or full radii are required.

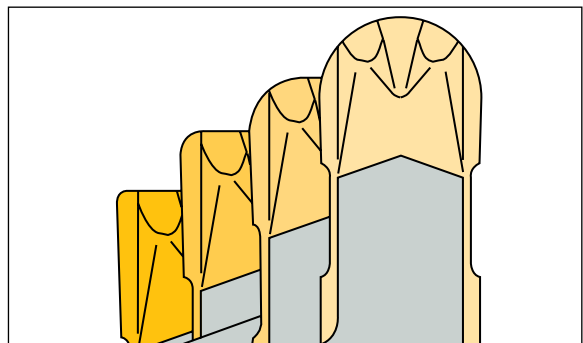

Machining Tips

Correct grooving sequence

When making a groove where the insert's width is not identical to the groove, it is recommended to select an insert that will enable grooving symmetrically in such

a way that the material is always in the center of the insert. This practice will ensure better chipbreaking and symmetrical cutting forces.

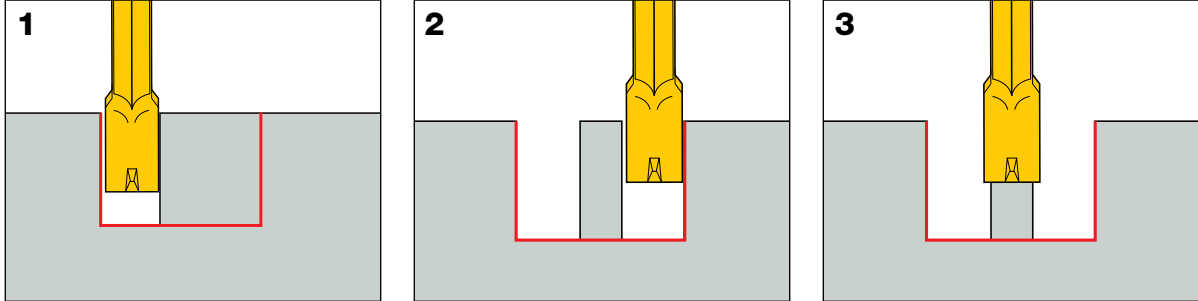

Eliminating a "Hanging Ring"

When turning at the end of a bar or towards a recess between two walls, a "hanging ring" may be formed. To eliminate the unwanted "hanging ring":

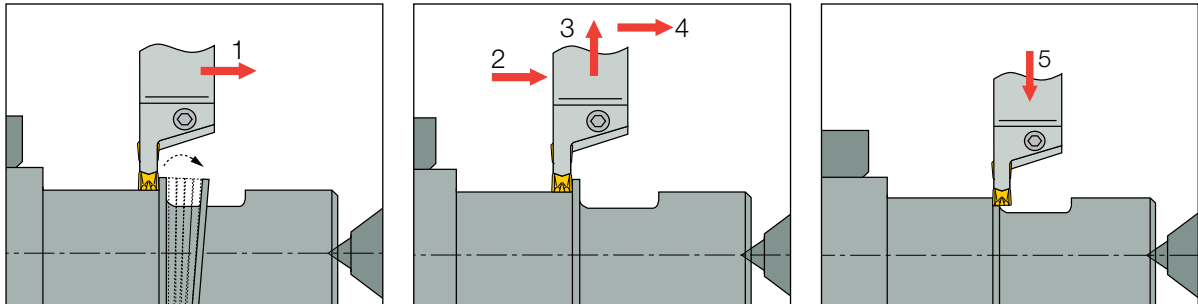

1. Turn toward the recess. Stop a short distance before reaching the recess.
2. Pull back the groove-turn tool and re-position it.
3. Machine as shown. This final operation achieves the size and flatness of the side wall.

Internal Machining

Improving Internal Turning in a Blind Hole

Internal turning in a blind hole brings about the problem of chip exit. When the tool reaches the rear side wall, chips may be caught between the wall and the insert, possibly causing insert breakage. Two solutions that can eliminate this problem:

First Solution

1. Start by grooving at the rear wall.
2. Continue by turning from the inside toward the outside.

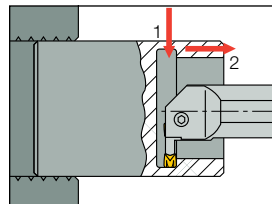

Second Solution

1. Start by grooving at the rear wall.
2. Pull the tool back the outside.
3. Turn the final diameter from outside, toward the groove.

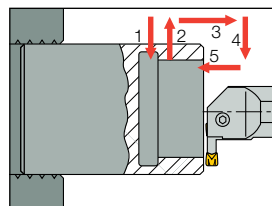

Optimizing Internal Machining Toolholder Overhang

It is always recommended to use the minimum possible overhang in order to maintain maximum toolholder rigidity. As a general rule, maximum overhang should not exceed three times the holder-bar diameter.

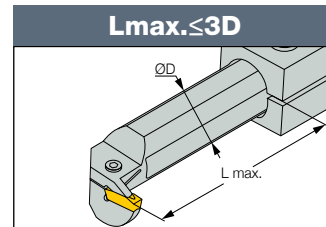

Finishing Operation: Diameter Compensation

A compensation factor for the final diameter must be used in the final machining operation. After the initial grooving to the required final diameter, the machining direction is normally changed for longitudinal turning. At this point the deflection occurs. If machining continues without correction, corner A will penetrate the material. This will result in two different diameters: øD1 from the grooving and øD2 from the turning. The difference between øD1 and øD2 is a value we define as Δ. The compensation factor is Δ/2, as shown below.

$$\frac{\Delta}{2} = \frac{\phi D^1 - \phi D^2}{2}$$

- Using the compensation factor will eliminate the small surface step. Follow this simple procedure during machining:
1. Groove to the final diameter
 2. Pull the tool back, a distance equal to the value of Δ/2
 3. Continue the finish turning operation

Characteristic values of Δ are shown in the diagrams on the next page.

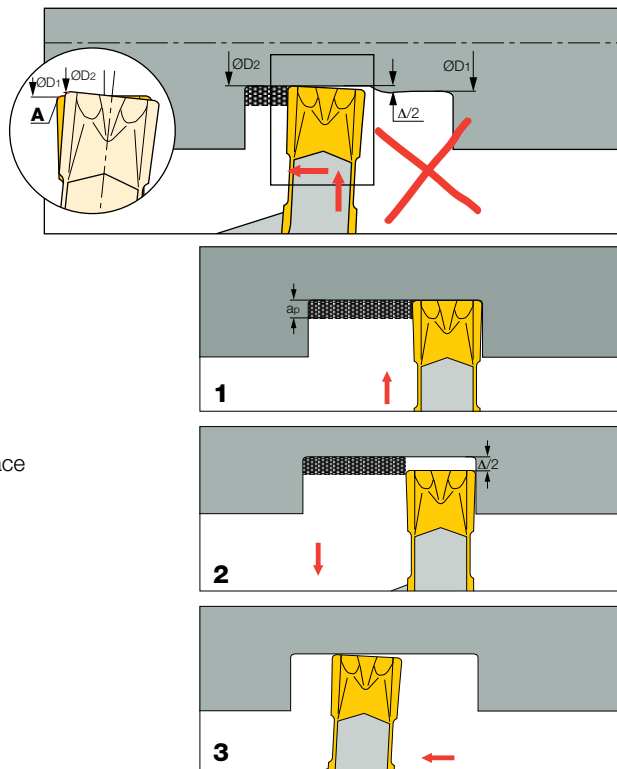

Characteristic Values of Δ

The diagrams show experimental results for specific machining conditions. These are sample values that will vary with different workpiece materials and different holder types.



Measure the Δ value for your finishing operation in a short test using your selected finishing conditions. Do not run your test using the final diameter.

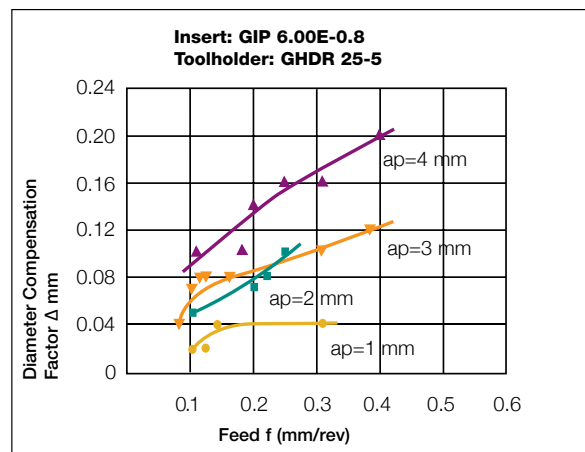
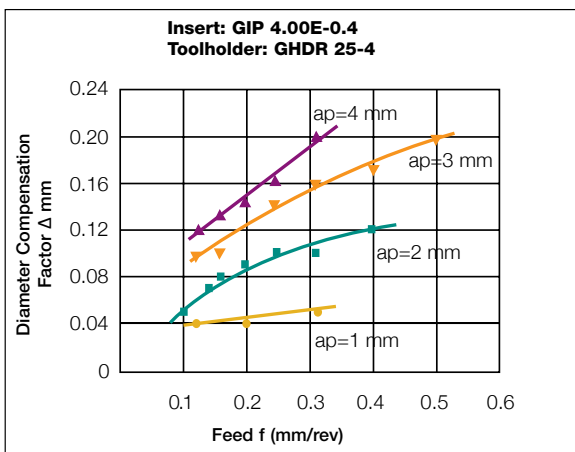
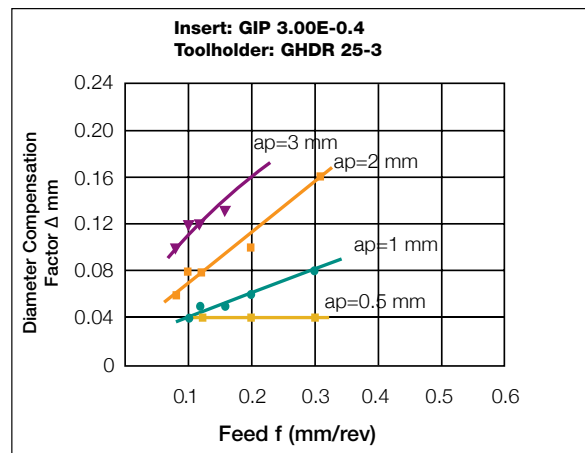

Multifunction Operations

The groove-turn tools are multifunction tools, able to operate in a sequence of grooving and turning modes. Moving from turning to grooving requires consideration of the basic Grip principle, thereby eliminating the possibility of insert breakage. In this situation one must release the side deflection which is necessary in turning, but not recommended in grooving.

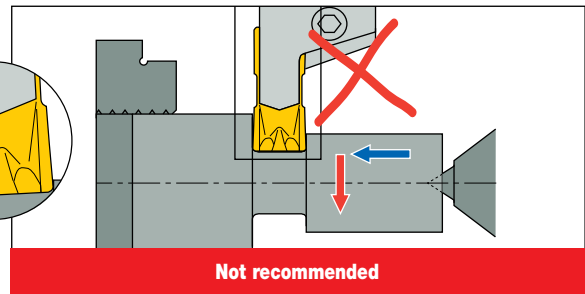
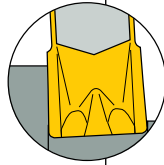

The following machining sequence is suggested: After completing the longitudinal turning, but before starting the grooving, the side deflection must be released. Move the tool in the direction opposite that of feed, approximately 0.1 mm, and return to the original position without side load.

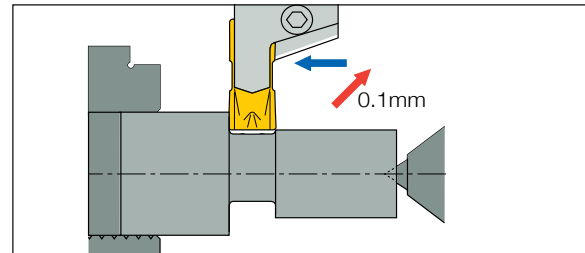

Then, after the deflection has been released and the holder is perpendicular to the workpiece, the grooving operation may start.

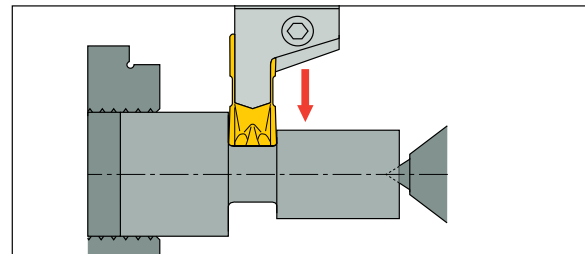

Machining Between Walls

One of the most important advantages of the GROOVE-TURN systems is the ability to machine between walls. To achieve the best results, the following sequence is recommended:

Roughing

Plunge to depth of cut. Pull back 0.2 mm radially. Turn longitudinally, retract at the end of the cut by 0.2 mm, simultaneously in radial and axial directions. Plunge again

and repeat same cycle leaving steps of 0.2 mm at the shoulders for the finishing cut. Minimum D.O.C. has to be $a_p \geq R_{x1.2}$ (corner radius).

Finishing

Plunge on the right side, reaching the tangent of the bottom radius. Retract and relieve the tangent point of the radius on the other side. Retract and machine all of the contour, pulling back by compensation value along the bottom (see page 390).

Roughing

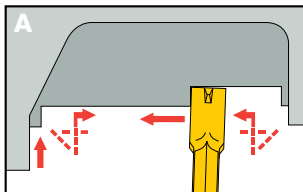

Roughing

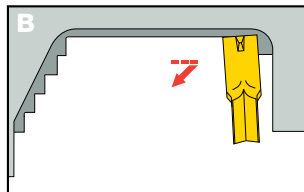

Finishing

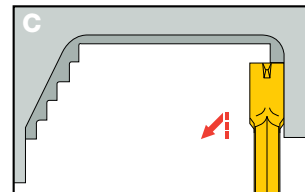

Finishing

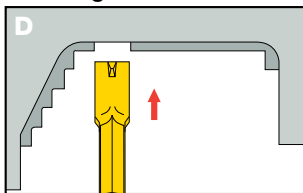

Finishing

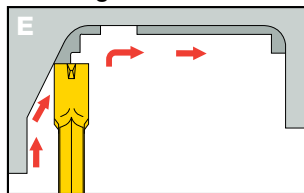

Finishing

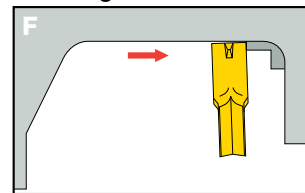

These instructions can be viewed at:
<http://www.youtube.com/watch?v=HXhEtc1zl4w>

Recommended Criteria for Replacement of the Cutting Edge

The cutting edge should be replaced in time to save costly downtime. The recommended value of wear at replacement is defined as the wear land size. The insert should be replaced when the wear land size is such that the increase in side forces is still small - not causing the insert to break and still maintaining the required workpiece tolerances. Wear is a function of machining time. The cutting edge should normally be replaced after 15 minutes of machining time.

Insert Wear - Tool Life

Wear on the Clearance Face

Wear land on groove turn inserts generally occurs at the corner of the clearance face **VB_n**, on the side near the corner **VB**, on the frontal cutting edge **VB_f** and at the end of the cutting side **VG**. The effective life of the cutting edge ends when any of the wear land values - **VB**, **VB**, **VB_f** or **VG** - exceed the recommended maximum values shown.

The largest wear land is normally measured at the corner of the clearance face **VB_n**. It has the most influence on the dimensions and tolerances of the final workpiece. The wear land shape on **GRIP** inserts differs slightly from that of **ISO** inserts. Although the frontal cutting surface of **GRIP** inserts absorbs more heat land wear, the wear land **VB_f** is generally negligible in turning operations when compared to **VB** and **VB_n**. Wear and may be found only occasionally at the end of the cutting side **VG**.

Crater Wear and Tool Life

Crater wear **KB** occurs on the rake face and is mainly affected by feed and cutting speed. Crater wear develops over time toward the frontal cutting edge.

If penetration of the frontal cutting edge occurs, it will immediately affect the quality of the machined surface.

Plastic Deformation

Plastic deformation occurs when the hardness of a cutting edge is decreased due to heat and pressure. The so-called "hot hardness" of the cutting tool material limits the feed and the cutting speed. Plastic deformation will affect the dimensions and tolerances of the finished product. It generally occurs when a small corner radius is used with high cutting speeds and high feeds. Using the proper insert geometry and the correct speed and feed ranges should eliminate the problem.

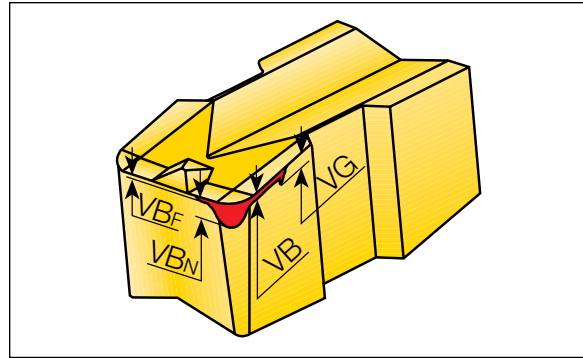

Maximum Recommended Wear Land Values Relative to Insert Widths

W Insert Width (mm)	Maximum Wear Land (mm)
≤3	0.20
4	0.22
5	0.25
6	0.27
8	0.27
≥10	0.30

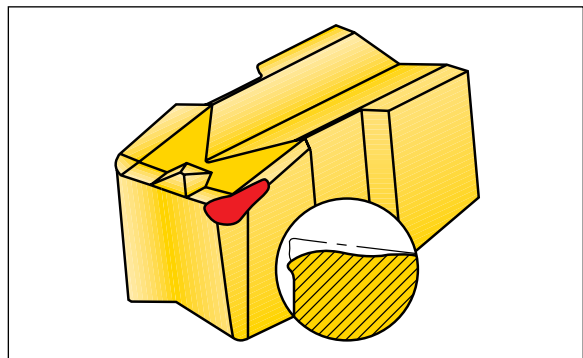
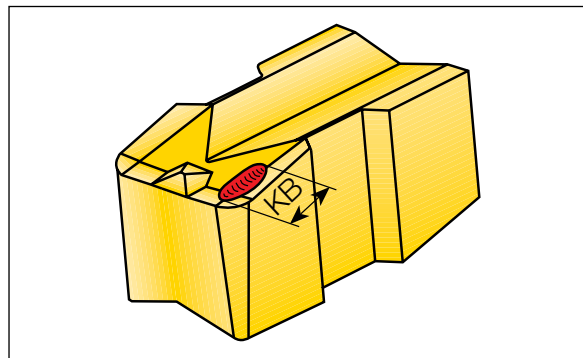

Machine Power Calculation

Calculation of Required Machine Power

Use the formulas below or use our internet web tool at: <http://mpwr.iscar.com/machiningpwr/machiningpower.wgx>

Turning

$$P = \frac{K_C \cdot a_p \cdot f \cdot v_C}{h \cdot 61 \cdot 10^3} \text{ [kW]}$$

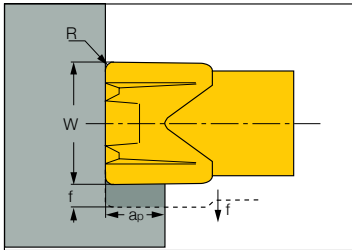

Grooving/Parting

$$P = \frac{K_C \cdot W \cdot f \cdot v_C}{h \cdot 61 \cdot 10^3} \text{ [kW]}$$

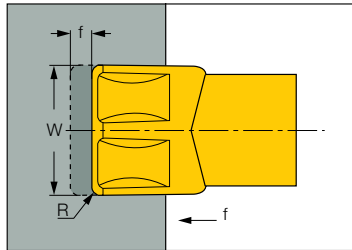

Face Grooving

$$P = \frac{K_C \cdot W \cdot f \cdot v_C}{h \cdot 61 \cdot 10^3} \text{ [kW]}$$

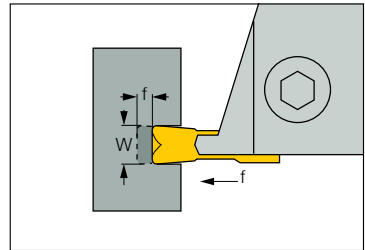

Where:

- K_C**- Specific cutting forces (N/mm²), turning values could be used
- h**- Efficiency (h≈0.8)

K_C Values

Mtl. Gr. No.	K _C [N/mm ²]	Mtl. Gr. No.	K _C [N/mm ²]
1	2000	21	500
2	2100	22	800
3	2150	23	800
4	2200	26	700
5	2100	27	700
6	2100	28	1700
7	2100	31	3000
8	2100	32	3100
9	2100	33	3300
10	2500	34	3300
11	3250	35	3200
12	2300	36	1700
13	2800	37	1700
14	2600	38	4600
15	1100	39	4700
16	1300	40	4600
17	1100	41	4500
18	1800		
19	900		
20	1000		

For material groups, see page 380

M-type Tools

- M-type tools have no support under the insert's cutting edge
- For an insert with a width smaller than 2.2 mm, there are no standard catalog tools available. There are 2 options as to how to use these narrow inserts:
 - Modify an existing tool and adjust the support under the insert to the required width
 - Use a standard M-type tool without support
- In wider widths, there are also cases where the support under the insert will disturb machining (threading inserts, pulley-V inserts and various specially tailored inserts) and therefore the above explanation should be considered
- These tools also provide the option for customers to use a very wide range of insert widths on the same tool (up to 6.4 mm)
- Machining conditions need to be light due to little support and limited gripping forces**



Recommended Clamping Torques and Interchangeable Key Blades and Adjustable Torque Handles (optional) for GROOVE-TURN Tools



TOP-GRIP

Tool	Recommended Torque Range [Nm]	Adjustable Torque Handle	Key Blade
TGDR/L			
TGDR/L 1616-3M	6-7	TSA 6 5-14	BLD 6 HEX4
TGDR/L 1616-4M	7-8		BLD 6 HEX4
TGDR/L 2020-3M	7-8		BLD 6 HEX4
TGDR/L 2020-4M	7-8		BLD 6 HEX4
TGDR/L 2525-3M	7-8		BLD 6 HEX4
TGDR/L 2525-4M	6-7		BLD 6 HEX4
TGDR/L 2525-5M	6-7		BLD 6 HEX4
TGDR/L 2525-6M	8-9		BLD 6 HEX5
TGDR/L 3232-5M	7-8		BLD 6 HEX5
TGDR/L 3232-6M	12-13		BLD 6 HEX5

HELI-GRIP

Tool	Recommended Torque Range [Nm]	Adjustable Torque Handle	Key Blade
HELIR/L			
HELIR/L 1212-3T12	5-6	TSA 6 5-14	BLD 6 HEX4
HELIR/L 1616-3T12	7-8		BLD 6 HEX4
HELIR/L 1616-3T20	8-9		BLD 6 HEX5
HELIR/L 1616-4T12	5-6		BLD 6 HEX4
HELIR/L 1616-4T20	11-12		BLD 6 HEX5
HELIR/L 2020-3T12	6-7		BLD 6 HEX4
HELIR/L 2020-3T20	7-8		BLD 6 HEX5
HELIR/L 2020-4T12	6-7		BLD 6 HEX4
HELIR/L 2020-4T25	7-8		BLD 6 HEX5
HELIR/L 2020-5T12	7-8		BLD 6 HEX5
HELIR/L 2020-5T25	9-10		BLD 6 HEX5
HELIR/L 2525-3T12	6-7		BLD 6 HEX4
HELIR/L 2525-3T20	10-11		BLD 6 HEX5
HELIR/L 2525-4T12	6-7		BLD 6 HEX4
HELIR/L 2525-4T25	8-9		BLD 6 HEX5
HELIR/L 2525-5T12	8-9		BLD 6 HEX5
HELIR/L 2525-5T25	10-11		BLD 6 HEX5
HELIR/L 2525-6T12	11-12		BLD 6 HEX5
HELIR/L 2525-6T30	10-11		BLD 6 HEX5
HELIR/L 3232-3T20	9-10		BLD 6 HEX5
HELIR/L 3232-4T25	9-10	BLD 6 HEX5	
HELIR/L 3232-5T25	10-11	BLD 6 HEX5	
HELIR/L 3232-6T30	11-12	BLD 6 HEX5	
HELIR/L 4032-4T25	9-10	BLD 6 HEX5	

CUT-GRIP

Tool	Recommended Torque Range [Nm]	Adjustable Torque Handle	Key Blade
GHDR/L (short pocket)			
GHDR/L 12-3	4-5	TSA 6 5-14	BLD 6 T20
GHDR/L 16-3	5-6		BLD 6 HEX4
GHDR/L 16-3 ST	5-6		BLD 6 HEX4
GHDR/L 16-4	7-8		BLD 6 HEX5
GHDR/L 16-4 ST	7-8		BLD 6 HEX5
GHDR/L 20-3	5-6		BLD 6 HEX4
GHDR/L 20-4	7-8		BLD 6 HEX5
GHDR/L 20-5	8-9		BLD 6 HEX5
GHDR/L 25-3	5-6		BLD 6 HEX4
GHDR/L 25-4	7-8		BLD 6 HEX5
GHDR/L 25-5	8-9		BLD 6 HEX5
GHDR/L 25-6	9-10		BLD 6 HEX5
GHDR/L 32-3	6-7		BLD 6 HEX4
GHDR/L 32-4	8-10		BLD 6 HEX5
GHDR/L 32-5	9-11		BLD 6 HEX5
GHDR/L 25-P8	13-14		BLD 6 HEX6
GHDR/L 32-P8	10-12		BLD 6 HEX6

GHDR/L-JHP (short pocket)	Recommended Torque Range [Nm]	Adjustable Torque Handle	Key Blade
GHDR/L 20-3-JHP	5-6	TSA 6 5-14	BLD 6 HEX4
GHDR/L 20-4-JHP	7-8		BLD 6 HEX5
GHDR/L 25-3-JHP	7-8		BLD 6 HEX4
GHDR/L 25-4-JHP	10-11		BLD 6 HEX5
GHDR/L 25-5-JHP	10-12		BLD 6 HEX5
GHDR/L 25-P8-JHP	10-11		BLD 6 HEX5

C#-HELIR/L	Recommended Torque Range [Nm]	Adjustable Torque Handle	Key Blade
C4 HELIR/L 3T20	9-10	TSA 6 5-14	BLD 6 HEX5
C4 HELIR/L 4T25	11-12		BLD 6 HEX5
C5 HELIR/L 3T20	10-11		BLD 6 HEX5
C5 HELIR/L 4T25	11-12		BLD 6 HEX5
C5 HELIR/L 5T25	11-12		BLD 6 HEX5
C6 HELIR/L 3T20	10-11		BLD 6 HEX5
C6 HELIR/L 4T25	12-13		BLD 6 HEX5
C6 HELIR/L 5T25	12-13		BLD 6 HEX5
C6 HELIR/L 6T30	13-14	BLD 6 HEX5	

CUT-GRIP

Tool	Recommended Torque Range [Nm]	Adjustable Torque Handle	Key Blade
------	-------------------------------	--------------------------	-----------

GHDR/L-JHP (long pocket)			
GHDR/L 32-8-JHP	15-17	Not Available	Not Available
GHDR/L-8A			
GHDR/L 25-8A	10-12	TSA 6 5-14	BLD 6 HEX5
GHDR/L 32-8A	10-12		BLD 6 HEX5

GHDR/L (long pocket)			
GHDR/L 25-8	10-12	TSA 6 5-14	BLD 6 HEX5
GHDR/L 25-812	10-12		BLD 6 HEX5
GHDR/L 32-8	10-12		BLD 6 HEX5
GHDR/L 3225-8	10-12		BLD 6 HEX5
GHDR/L 32-812	11-12		BLD 6 HEX5
GHDR/L 25-10	15-17	Not Available	Not Available
GHDR/L 32-836	16-17		
GHDR/L 32-10	15-17		
GHDR/L 40-10	16-17		

C#-GHDR/L			
C4 GHDR/L-3	6-7	TSA 6 5-14	BLD 6 HEX4
C4 GHDR/L-4	7-8		BLD 6 HEX5
C5 GHDR/L-3	6-7		BLD 6 HEX4
C5 GHDR/L-4	7-8		BLD 6 HEX5
C5 GHDR/L-5	8-9		BLD 6 HEX5
C6 GHDR/L-3	6-7		BLD 6 HEX4
C6 GHDR/L-4	7-8		BLD 6 HEX5
C6 GHDR/L-5	8-9		BLD 6 HEX5
C6 GHDR/L-8	10-12		BLD 6 HEX5

GHDR/L/N 12/14			
GHDR/L 2525-14T12	16-17	Not Available	Not Available
GHDR/L 32-12	15-16		
GHDR/L 3232-14T12	16-17		
GHDR/L 3232-14T38	18-20		
GHDN 3232-14T38	18-20		
GHDR/L 4040-14T38	18-20		
GHDN 4040-14T38	18-20		

GHGR/L			
GHGR/L 16-3	7-8	TSA 6 5-14	BLD 6 HEX5
GHGR/L 16-3 ST	7-8		BLD 6 HEX5
GHGR/L 16-4	7-8		BLD 6 HEX5
GHGR/L 20-2	4-6	HSA 4 1-5	BLD 4 HEX4
GHGR/L 20-3	7-8	TSA 6 5-14	BLD 6 HEX5
GHGR/L 20-4	7-8		BLD 6 HEX5
GHGR/L 25-2	4-5	HSA 4 1-5	BLD 4 HEX4
GHGR/L 25-3	6-8	TSA 6 5-14	BLD 6 HEX5
GHGR/L 25-4	8-10		BLD 6 HEX5
GHGR/L 25-425	8-10		BLD 6 HEX5
GHGR/L 25-5	9-11		BLD 6 HEX5
GHGR/L 25-630	10-12		BLD 6 HEX5
GHGR/L 32-5	10-12		BLD 6 HEX5
GHGR/L 32-632	10-12		BLD 6 HEX5

Tool	Recommended Torque Range [Nm]	Adjustable Torque Handle	Key Blade
------	-------------------------------	--------------------------	-----------

GHMR/L			
GHMR/L 12	8-9	TSA 6 5-14	BLD 6 T20
GHMR/L 16	10-12		BLD 6 HEX5
GHMR/L 16-3 ST	10-12		BLD 6 HEX5
GHMR/L 20	10-12		BLD 6 HEX5
GHMR/L 25	10-12		BLD 6 HEX5
GHMR/L 32	10-12		BLD 6 HEX5

GHMPR/L			
GHMPR/L 16	4-5	TSA 6 5-14	BLD 6 HEX5
GHMPR/L 20	5-6		BLD 6 HEX5
GHMPR/L 25	8-9		BLD 6 HEX5

GHMUR/L			
GHMUR/L 16	6-7	TSA 6 5-14	BLD 6 HEX5
GHMUR/L 20	8-10		BLD 6 HEX5
GHMUR/L 25	10-11		BLD 6 HEX5

GHSR/L			
GHSR/L 10-2	2-3	HSA 4 1-5	BLD 4 T15
GHSR/L 12-2	2-3		BLD 4 T15
GHSR/L 14-2	2-3		BLD 4 T15
GHSR/L 16-2	4-5	TSA 6 5-14	BLD 6 T20

CGHN-P8			
CGHN 52-P8	6-7	TSA 6 5-14	BLD 6 HEX4
CGHN 53-P8	6-7		BLD 6 HEX4

CGHN-8-10D			
CGHN 52-8D	7-8	TSA 6 5-14	BLD 6 HEX4
CGHN 53-8D	7-8		BLD 6 HEX4
CGHN 52-10D	9-11		BLD 6 HEX5
CGHN 53-10D	9-11		BLD 6 HEX5

CGHR/L-12-14D			
CGHR/L 53-12D	10-12	TSA 6 5-14	BLD 6 HEX5
CGHR/L 53-14D	10-12		BLD 6 HEX5

All JETCUT tools also provide great advantages to standard low-pressure (7-10 Bars) machine tools

The **JETCUT** tools provide a great advantage when standard machine pressure (10-20 bars) is applied and on a wide range of popular materials such as alloy & stainless steel, improving their tool life and in some cases chip control.

The main reasons for the improvement in both high and low pressure are:

- The **JETCUT** coolant is pinpointed exactly to the cutting edge where it is most effective.



- The **JETCUT** coolant is steady and not influenced by the operator's attention or interrupted by the chips.



- In parting-off and deep grooving, external coolant loses its effectiveness as the groove becomes deeper. With **JETCUT** tools and blades, the coolant delivery is not influenced by the groove's depth.



These advantages were reported by many customers and are presented in various test reports.

	PENTAIQGRIP	PENTAIQGRIP JETCUT
Material	Stainless Steel AISI 316	
Operation	Grooving	
Pressure (Bar)	10 (external)	10 (Internal)
Tool	PCHR 25-D40-3	PCHR 25-D40-3- JHP
Insert	PENTA D40N300C020 IC808G	
Vc (mm/min)	180	
f (mm/rev)	0.2	
Toolife (number of grooves)	110	200

Tool life increase 82%

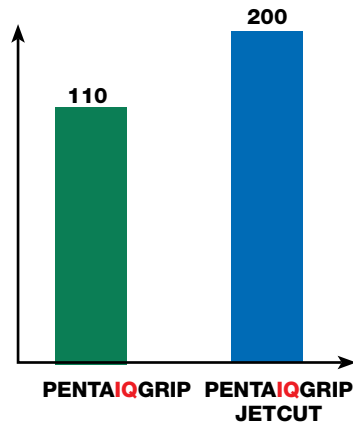

	CUT-GRIP	CUT-GRIP JETCUT
Material	Stainless Steel 1.4301 (AISI 304)	
Operation	External Grooving	
Pressure (Bar)	20 (external)	20 (Internal)
Tool	GHDR 20-4	GHDR 20-4- JHP
Insert	GIP 4.00E-0.4 IC808	GIP 4.00E-0.4 IC808
Vc (m/min)	120	140
f (mm/rev)	0.12	0.2
Cycle time (min)	128.5	67.4
Parts/Edge	10	12

Tool life increase 20%

Cycle time improvement 52%

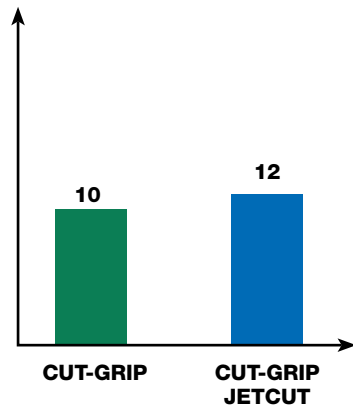

JETCUT Tools High Pressure (up to 340 Bar)

The high pressure coolant feature has been in existence for a long time in the metal removal world, taking a bigger role in today's machining.

ISCAR was one of the first cutting tools companies to respond to market needs by designing and producing tools for ultra high and high pressure coolant flow.

High pressure coolant was initially implemented mainly for difficult-to-machine materials such as titanium, Inconel and other heat resistant alloys. Later it was found that tool life, productivity and chip control can be improved when machining stainless and alloyed steel.

JETCUT tools are essential and important in the aviation, aerospace and medical industries.

How does it work?

The stream velocity of the coolant emitted from the pump increases as the coolant holes become smaller. When it emerges out of the tool through the nozzle, the velocity is very high, exerting considerable force on the chips, lowering their temperature and protecting the cutting edge from thermal shock. High temperature alloys produce a very high temperature as they are being cut. By effectively removing the heat, the chips become less ductile and thus easier to break. Shorter chips are easily managed - they do not tangle around the workpiece or machine parts, so there is no need to stop the process frequently. Usually in conventional cooling the chip prevents the coolant from reaching the insert rake face in the cutting zone. The coolant stream of the **JETCUT** tools is directed precisely between the insert rake face and the flowing chip. This results in longer tool life and a much more reliable process.

The coolant channels of the **JETCUT** tools feature outlets very close to the cutting edges, thus gaining the following advantages:

- Shorter machining time – the cutting speed may be increased by up to 200% when machining titanium & heat resistant alloys
- Longer tool life – tool life increases by up to 100% not only on titanium and heat resistant alloys, but also on stainless and alloy steels
- Improved chip control – even on the most ductile and problematic materials, small chips can be obtained
- Very effective cooling down of the cutting edge, which reduces sensitivity to heat fluctuations
- Safer and more stable process

 **JETCUT** tools provide advantageous performance also when conventional pressure is applied.

General Information

Pressure Ranges

Up to 30 Bar – Low pressure (**LP**) may provide some improvement in tool life. Usually will not have an effect on chip control.

30 – 120 Bar – High pressure (**HP**) the most commonly used pressure range used with **JETCUT** tools.

Increase in tool life, increase in cutting speeds, improved chip control.

120 – 400 Bar – Ultra high pressure (**UHP**) requires special tool design in order to take advantage of the extra pressure. Minor increase in tool life compared to **HP** range.

Ultra high pressure coolant is usually implemented for machining titanium and heat resistant alloys when there is a need for very small chips and higher machining rates.

Since 2000, **ISCAR** has provided hundreds of special tools featuring ultra high pressure coolant capability, for various customers and applications.

Pressure vs. Flow

Each **JETCUT** tool is designed to work at a certain flow rate, depending on the pressure. The flow rates are listed in the catalog pages for each tool. The user should verify that the pump can supply the required flow in order to achieve the optimal results. The pump data sheet will usually list the maximum flow rate for each pressure range.

Chips & Pressure

The coolant flow will start to break the chips at a certain pressure, depending on the specific tool and the workpiece material. If the chips are not breaking, the pressure should be increased until chip control is achieved. Above this pressure, as it is increased the chips become smaller and smaller. It is possible to control the size of the chips by modifying the pressure in order to achieve the desired chip size.

High Pressure Coolant with Groove-Turn and Parting Tools

In grooving and parting operations, applying high pressure coolant provides excellent chip breaking results on all materials. On exotic alloys such as Inconel and titanium, it is usually impossible to break the chips with standard external coolant pressure. Applying high coolant pressure provides excellent chip breaking results. On some alloyed and stainless steel, especially when low feeds are applied, high pressure coolant may solve chip breaking problems.

High pressure coolant reduces or even eliminates built-up edge phenomenon, especially when machining stainless steel and high temperature alloys.

In turning operations, applying high pressure coolant is less effective because the jet is directed to the frontal edge.

Assembly and Safety Guidelines When Using the JET HP ISO Turning and Grooving Tools

- Before use, please ensure that:
- The machine door is in a fully closed position
 - The coolant hose is in the correct location and fully tightened with all seals in position
 - A blank plug is inserted into the unused coolant hole
 - All O-rings and washers are in place
 - The coolant hose is tightened securely to the toolholder and tool block, to prevent leakage of coolant

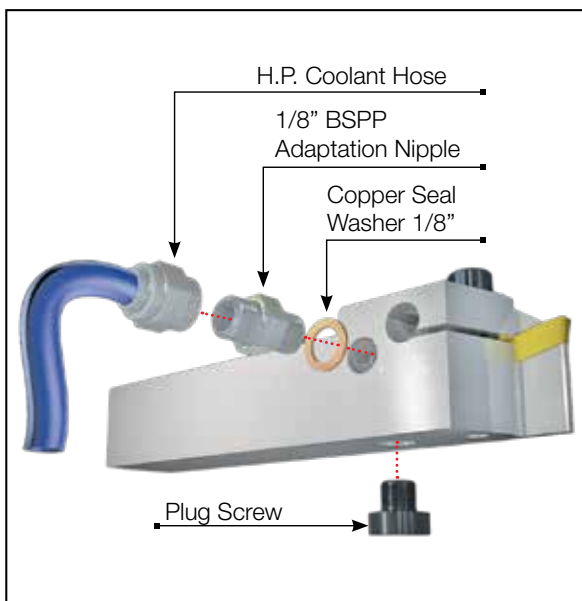

Grooving Test

Material: Titanium (Ti6Al4v)
Operation: Grooving
Tool: GHDL 25-6-JHP
Insert: GIMF 608 IC07
Vc: 50 mm/min
f: 0.15 mm/rev



Pressure [bar]		
10 (External)	70	350

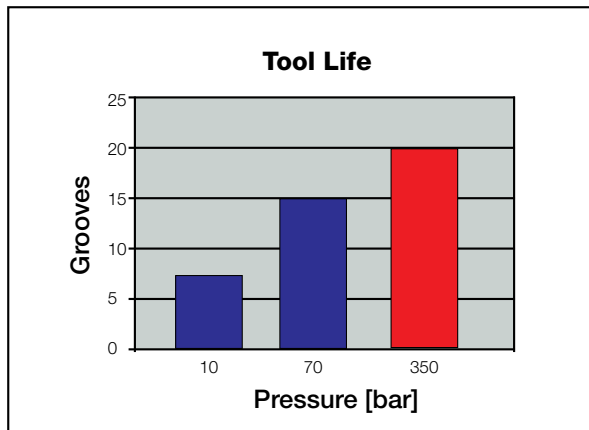

Important

Always pay attention not to exceed the maximum safe working pressure for **GROOVE-TURN tools 340 bar** and **PARTING OFF tools 300 bar**.

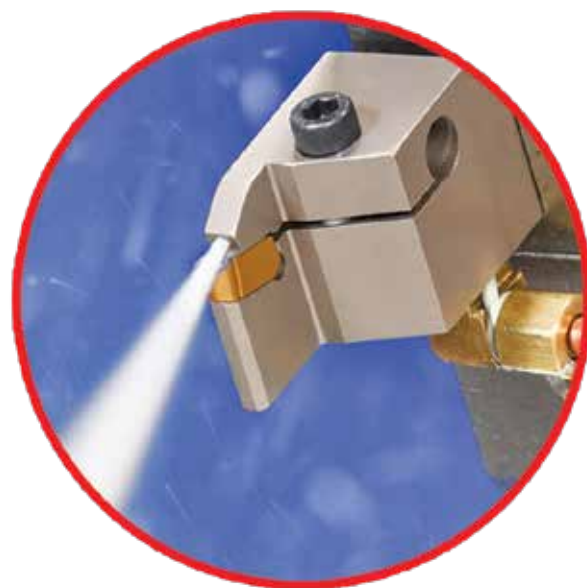

Accessories

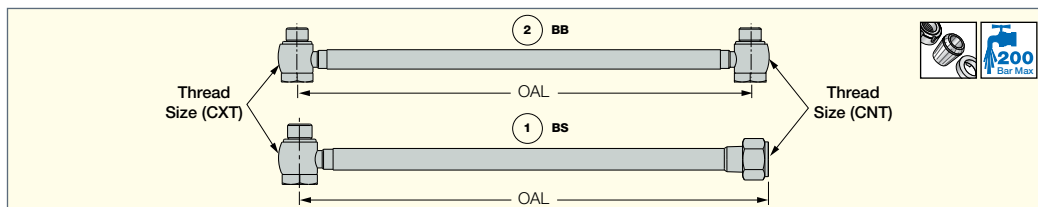

JHP HOSE

High Pressure Coolant Hose



Designation	OAL	Fig.	CXT	CNT
JHP HOSE G1/8-7/16-200BS	200.00	1.	G1/8"-28 BSPP	UNF7/16"-20FLARE 37°
JHP HOSE 5/16-G1/8-200BS	200.00	1.	5/16"-24 UNF	G1/8"-28 BSPP
JHP HOSE 5/16-7/16-200BS	200.00	1.	5/16"-24 UNF	UNF7/16"-20FLARE 37°
JHP HOSE G1/8-G1/8-200BB	200.00	2.	G1/8"-28 BSPP	G1/8"-28 BSPP
JHP HOSE G1/8-7/16-250BS	250.00	1.	G1/8"-28 BSPP	UNF7/16"-20FLARE 37°
JHP HOSE G1/8-G1/8-250BB	250.00	2.	G1/8"-28 BSPP	G1/8"-28 BSPP

Spare Parts

Designation		
JHP HOSE 5/16-7/16-200BS	JHP BANJO BOLT 5/16" UNF	JHP COPPER SEAL 5/16"
JHP HOSE G1/8-G1/8-200BB	JHP BANJO BOLT G1/8**	JHP COPPER SEAL 1/8**
JHP HOSE G1/8-G1/8-250BB	JHP BANJO BOLT G1/8**	JHP COPPER SEAL 1/8**

* Optional, should be ordered separately

Accessories

JHP NIPPLE

High Pressure Adaptation Nipple

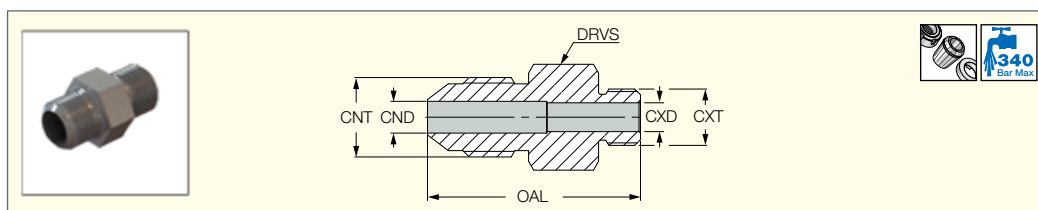

Designation	CXT	CNT	OAL	CND	CXD	DRVS ⁽¹⁾
JHP NIPPLE G1/8"-7/16"UNF	1/8"-28 BSPP	7/16"-20 UNF	28.75	4.00	4.00	14.3
JHP NIPPLE 1/8NPT-7/16UNF	1/8"-27 NPT	7/16"-20 UNF	31.00	4.80	4.40	12.7
JHP NIPPLE 1/4NPT-7/16UNF	1/4"-18 NPT	7/16"-20 UNF	36.00	4.40	4.40	14.3
JHP NIPPL 5/16UNF-7/16UNF	5/16"-24 UNF	7/16"-20 UNF	29.50	4.40	4.00	12.7

⁽¹⁾ Key flat size

Accessories

JHP ELBOW

High Pressure Adaptation Elbow

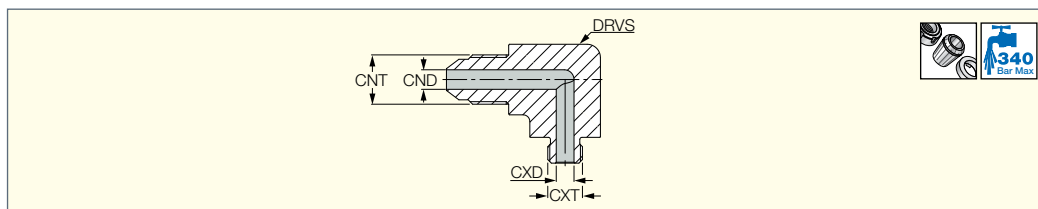

Designation	CNT	CND	CXT	CXD	DRVS ⁽¹⁾
JHP ELBOW 90-G1/8-7/16UNF	7/16"-20 UNF	4.40	1/8"-28 BSPP	4.00	15.9
JHP ELBOW 90-5/16-7/16UNF	7/16"-20 UNF	4.40	5/16"-24 UNF	4.00	12.7

⁽¹⁾ Key flat size

Spare Parts

Designation	
JHP ELBOW 90-G1/8-7/16UNF	JHP COPPER SEAL 1/8"
JHP ELBOW 90-5/16-7/16UNF	JHP COPPER SEAL 5/16"-2.5

Accessories

JHP CONNECTOR
High Pressure Connector

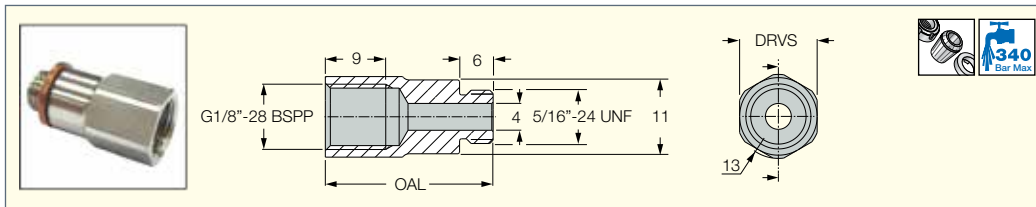

Designation	OAL	DRVS ⁽¹⁾
JHP CONECTOR 5/16"-G1/8"	25.00	12.0

⁽¹⁾ Key flat size

Accessories

JHP COPPER SEAL
High Pressure Copper Seal

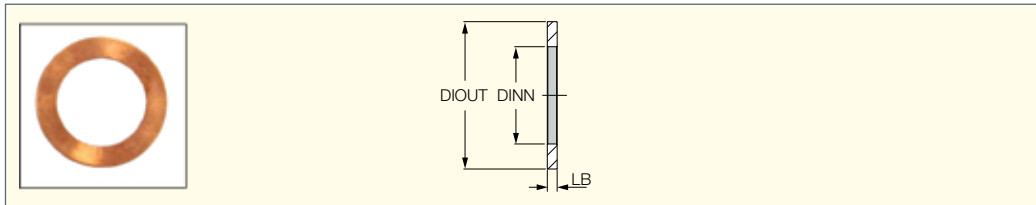

Designation	DIOUT	DINN	LB
JHP COPPER SEAL 5/16"-2.5	9.40	8.00	2.50
JHP COPPER SEAL 5/16"	11.90	8.15	1.35
JHP COPPER SEAL 1/8"	15.00	10.00	1.00



ISCARBROACH

SXCIB

Broaching Holders for Lathe and Milling Machines

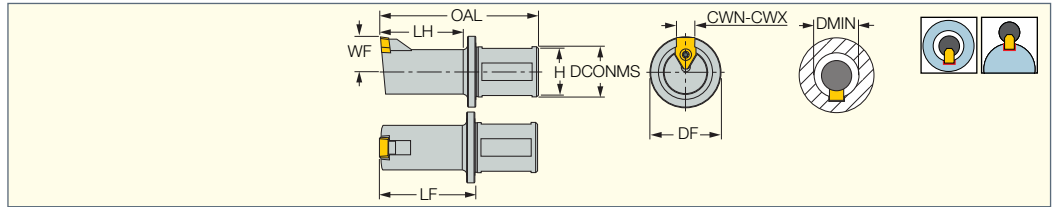

Designation	DCONMS	OAL	LH	LF	CWN ⁽¹⁾	CWX ⁽²⁾	WF	DMIN	H	DF	Insert		
SXCIB 25-22-50	25.00	100.00	50.0	60.00	5.00	12.00	12.00	22.00	23.0	33.0	Group #1	SR M5X13 T20	T-20/5
SXCIB 32-30-50	32.00	100.00	50.0	60.00	5.00	12.00	16.50	30.00	30.0	45.0	Group #2	SR M5X13 T20	T-20/5
SXCIB 32-38-50	32.00	100.00	50.0	60.00	5.00	12.00	22.00	38.00	30.0	45.0	Group #3	SR M5X13 T20	T-20/5
SXCIB 32-30-75	32.00	125.00	75.0	85.00	5.00	12.00	16.50	30.00	30.0	45.0	Group #2	SR M5X13 T20	T-20/5
SXCIB 32-38-75	32.00	125.00	75.0	85.00	5.00	12.00	22.00	38.00	30.0	45.0	Group #3	SR M5X13 T20	T-20/5

⁽¹⁾ Minimum cutting width

⁽²⁾ Maximum cutting width

For inserts, see pages: XNUWB (401) • XNUWB (light fit) (402) • XNUWB (tight fit) (402)

Insert Group #1	Insert Group #2	Insert Group #3
XNUWB 13-4.98-0.2	XNUWB 13-7.98-0.2	XNUWB 13-10.13-1.05
XNUWB 13-5.01-0.2	XNUWB 13-8.13-1.05	XNUWB 13-11.98-0.3
XNUWB 13-5.98-0.2	XNUWB 13-9.98-0.3	XNUWB 13-12.02-0.3
XNUWB 13-6.01-0.2	XNUWB 13-10.01-0.3	XNUWB 13-12.02-0.5
XNUWB 13-6.12-0.85		XNUWB 13-12.15-1.35
XNUWB 13-7.13-0.85		XNUWB 13-12.15-1.75
XNUWB 13-7.98-0.2		XNUWB 13-12.15-2.25
XNUWB 13-8.01-0.2		
XNUWB 13-8.13-1.05		

Spare Parts Clamping screw: SR M5X13 T20 Key: T-20/5

ISCARBROACH

XNUWB

DIN138 (Tolerance C11) Inserts for Keyway Broaching on Lathe and Milling Machines

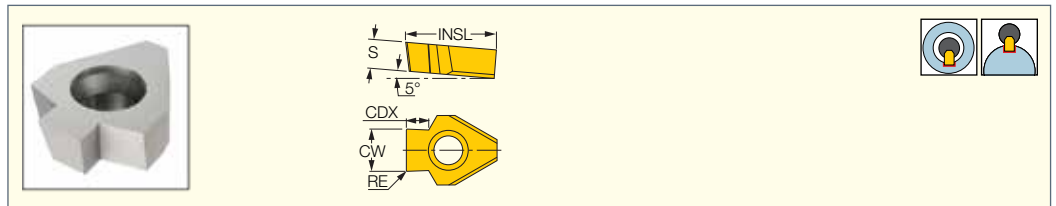

Designation	Dimensions							IC908
	CW	RE	CWTOL ⁽¹⁾	RETOL ⁽²⁾	INSL	CDX	S	
XNUWB 13-6.12-0.85	6.12	0.85	0.02	0.050	17.30	2.60	5.30	•
XNUWB 13-7.13-0.85	7.13	0.85	0.02	0.050	17.30	3.30	5.30	•
XNUWB 13-8.13-1.05	8.13	1.05	0.02	0.050	17.30	3.40	5.30	•
XNUWB 13-10.13-1.05	10.13	1.05	0.02	0.050	20.20	4.20	5.30	•
XNUWB 13-12.15-1.35	12.15	1.35	0.02	0.050	20.20	5.10	5.30	•
XNUWB 13-12.15-1.75	12.15	1.75	0.02	0.050	20.20	6.60	5.30	•
XNUWB 13-12.15-2.25	12.15	2.25	0.02	0.050	20.20	8.50	5.30	•

• Typical conditions: Vc = 4000-8000 mm/min, ap = 0.02-0.08 mm

⁽¹⁾ Cutting width tolerance (+/-)

⁽²⁾ Corner radius tolerance (+/-)

For tools, see pages: SXCIB (401)

ISCARBROACH

XNUWB (light fit)
DIN6885 Inserts for Light Fit (JS9) Keyway Broaching on Lathe and Milling Machines

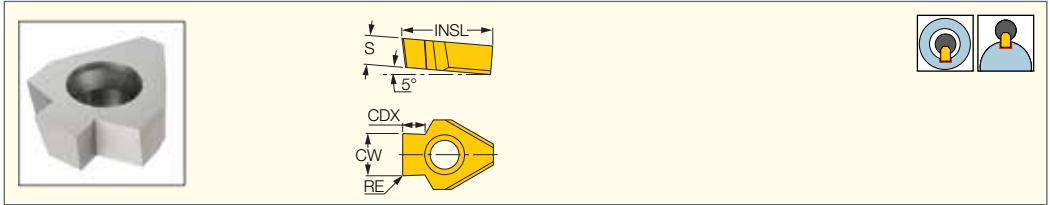

Designation	Dimensions						IC908
	CW ⁽¹⁾	RE	RETOL ⁽²⁾	INSL	CDX ⁽³⁾	S	
XNUWB 13-5.01-0.2	5.01	0.20	0.030	17.30	2.70	5.30	●
XNUWB 13-6.01-0.2	6.01	0.20	0.030	17.30	3.40	5.30	●
XNUWB 13-8.01-0.2	8.01	0.20	0.030	17.30	4.10	5.30	●
XNUWB 13-10.01-0.3	10.01	0.30	0.030	17.30	4.20	5.30	●
XNUWB 13-12.02-0.3	12.02	0.30	0.030	20.20	5.70	5.30	●
XNUWB 13-12.02-0.5	12.02	0.50	0.050	20.20	8.50	5.30	●

• Typical conditions: Vc = 4000-8000 mm/min, ap = 0.02-0.08 mm

⁽¹⁾ Tolerance: +0 -0.03

⁽²⁾ Corner radius tolerance (+/-)

⁽³⁾ Cutting depth maximum

ISCARBROACH

XNUWB (tight fit)
DIN6885 Inserts for Tight Fit (P9) Keyway Broaching on Lathe and Milling Machines

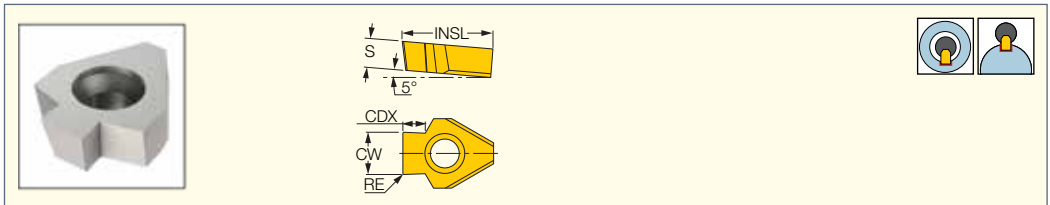

Designation	Dimensions						IC908
	CW ⁽¹⁾	RE	INSL	CDX	S		
XNUWB 13-4.98-0.2	4.98	0.20	17.30	2.70	5.30	●	
XNUWB 13-5.98-0.2	5.98	0.20	17.30	3.40	5.30	●	
XNUWB 13-7.98-0.2	7.98	0.20	17.30	4.10	5.30	●	
XNUWB 13-9.98-0.3	9.98	0.30	17.30	4.20	5.30	●	
XNUWB 13-11.98-0.3	11.98	0.30	20.20	5.70	5.30	●	

• Typical conditions: Vc = 4000-8000 mm/min, ap = 0.02-0.08 mm

⁽¹⁾ Tolerance: +0 -0.03

For tools, see pages: SXCIB (401)





ISCARBROACH

BHDN

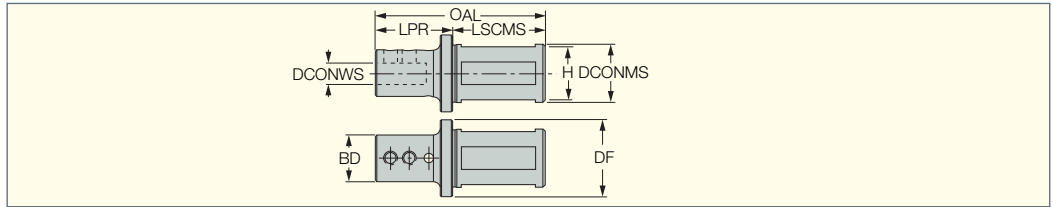
Broaching Holders for Lathe and Milling Machines



Designation	DCONWS	DCONMS	BD	DF	LPR	OAL	LSCMS	H	Insert		
BHDN 25-10-33	10.00	25.00	20.00	33.00	33.00	73.00	40.00	23.0	SCB 010	SR M5X6 DIN913	HW 2.5
BHDN 32-10-33	10.00	32.00	20.00	40.00	33.00	73.00	40.00	30.0	SCB 010	SR M5X6 DIN913	HW 2.5

• Holders are suitable for left- and right-hand mini-bars and ISO bars

ISCARBROACH

SCB

DIN138 (Tolerance C11) Inserts for Keyway Broaching on Lathe and Milling Machines

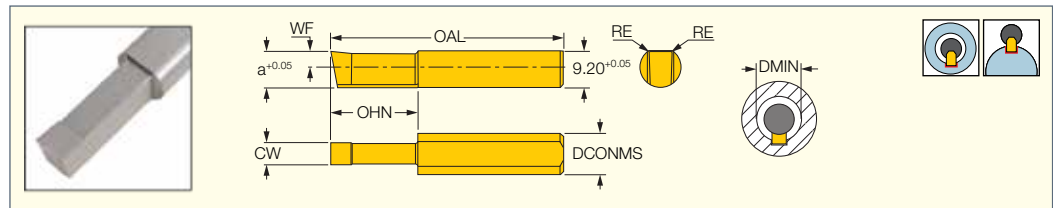

Designation	Dimensions									IC908
	CW	RE	DCONMS	WF	a	OAL	OHN ⁽¹⁾	DMIN		
SCB 010.410.050-25	4.10	0.50	10.00	4.00	9.00	50.00	25.0	10.00		•
SCB 010.410.050-41	4.10	0.50	10.00	4.00	9.00	66.00	41.0	10.00		•
SCB 010.510.050-25	5.10	0.50	10.00	4.00	9.00	50.00	25.0	10.00		•
SCB 010.510.050-41	5.10	0.50	10.00	4.00	9.00	66.00	41.0	10.00		•

• Typical conditions: Vc = 4000-8000 mm/min, ap = 0.02-0.08 mm

⁽¹⁾ Minimum overhang

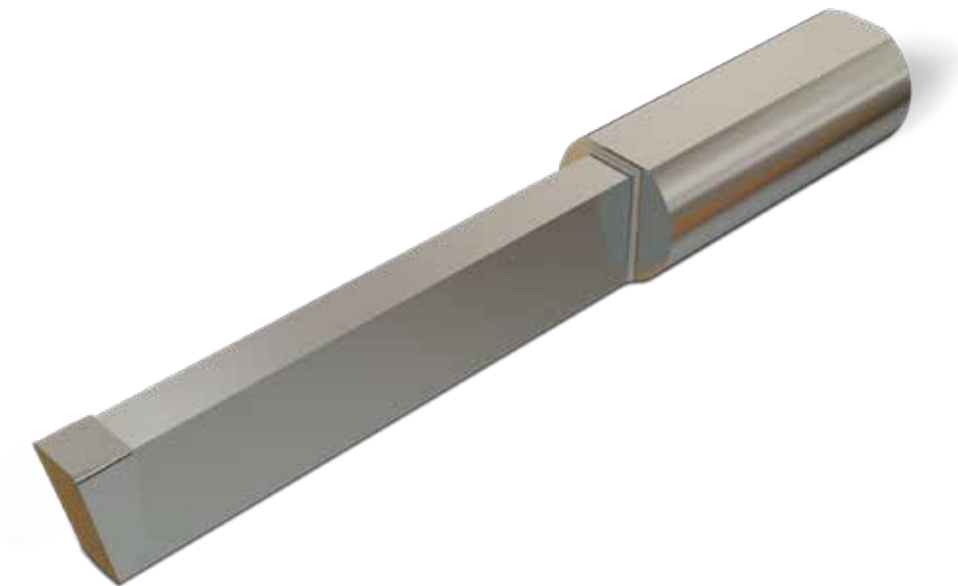

ISCARBROACH

SCB (light fit)

DIN6885 Inserts for Light Fit (JS9) Keyway Broaching on Lathe and Milling Machines

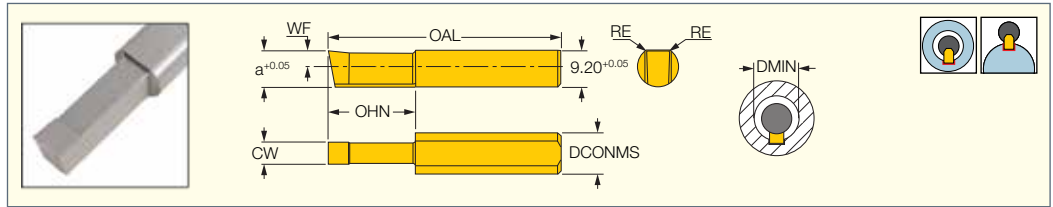

Dimensions									
Designation	CW	RE	DCONMS	WF	a	OAL	OHN ⁽¹⁾	DMIN	IC908
SCB 010.400.020-25	4.00	0.20	10.00	4.00	9.00	50.00	25.0	10.00	●
SCB 010.400.020-41	4.00	0.20	10.00	4.00	9.00	66.00	41.0	10.00	●
SCB 010.500.020-25	5.00	0.20	10.00	4.00	9.00	50.00	25.0	10.00	●
SCB 010.500.020-41	5.00	0.20	10.00	4.00	9.00	66.00	41.0	10.00	●

• Typical conditions: Vc = 4000-8000 mm/min, ap = 0.02-0.08 mm

⁽¹⁾ Minimum overhang

ISCARBROACH

SCB (tight fit)

DIN6885 Inserts for Tight Fit (P9) Keyway Broaching on Lathe and Milling Machines

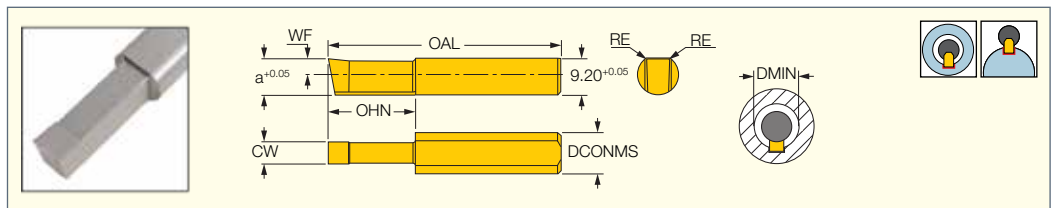

Dimensions									
Designation	CW ⁽¹⁾	RE	DCONMS	WF	a	OAL	OHN ⁽²⁾	DMIN	IC908
SCB 010.398.020-25	3.98	0.20	10.00	4.00	9.00	50.00	25.0	10.00	●
SCB 010.398.020-41	3.98	0.20	10.00	4.00	9.00	66.00	41.0	10.00	●
SCB 010.498.020-25	4.98	0.20	10.00	4.00	9.00	50.00	25.0	10.00	●
SCB 010.498.020-41	4.98	0.20	10.00	4.00	9.00	66.00	41.0	10.00	●

• Typical conditions: Vc = 4000-8000 mm/min, ap = 0.02-0.08 mm

⁽¹⁾ Tolerance: +0.01 -0.02

⁽²⁾ Minimum overhang

TOOLS FOR MACHINING ALUMINUM WHEELS



CUTGRIP

GHIUR/L-C-A (15° & 27.5°) Bars

Internal Grooving and Turning Bars for Machining Aluminum Wheels

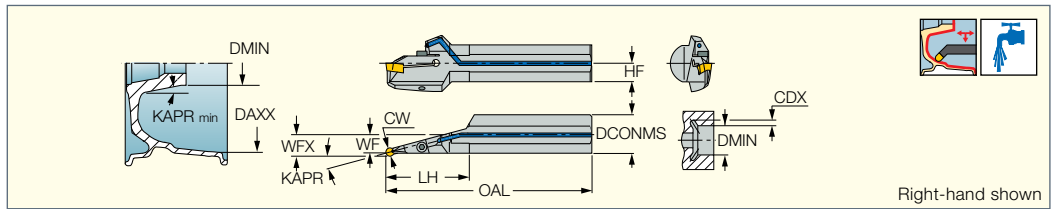

Right-hand shown

Designation	CW	DCONMS	DMIN	CDX ⁽¹⁾	OAL	LH	WFX	WF	HF	KAPR			
GHIUR/L 40C-15A-6	6.00	40.00	160.00	-	320.00	83.0	21.20	19.0	18.0	15.0	SR M5X20DIN912	HW 4.0	PL 40
GHIUR/L 40C-15A-8	8.00	40.00	160.00	0.00 ⁽²⁾	320.00	83.0	21.00	18.0	18.0	15.0	SR M6X20 DIN912	HW 5.0	PL 40
GHIUR/L 50C-15A-8	8.00	50.00	100.00	0.00 ⁽³⁾	350.00	83.0	26.00	23.0	23.0	15.0	SR M6X25 DIN912	HW 5.0	PL 40
GHIUR/L 40C-27.5A-6	6.00	40.00	90.00	0.60 ⁽⁴⁾	320.00	80.0	25.10	23.5	18.0	27.5	SR M6X25 DIN912	HW 5.0	PL 40
GHIUR/L 50C-27.5A-8	8.00	50.00	120.00	1.80 ⁽⁴⁾	350.00	82.0	30.20	28.0	23.0	27.5	SR M6X25 DIN912	HW 5.0	PL 40

• Upper jaw with hard coating to sustain chip deflection

- ⁽¹⁾ Dimension for minimum bore diameter
- ⁽²⁾ For bore diameter D>200, CDX is 0.5 mm
- ⁽³⁾ For bore diameter D>200, CDX is 1.4 mm
- ⁽⁴⁾ For bore diameter D>200, CDX is 4.0 mm

For inserts, see pages: GDMA (284) • GIPA (full radius W=3-6) (285) • GIPA 8-35V (V-shape) (409) • GIPA/GIDA 8 (full radius) (286)

CUTGRIP

GHIUR/L-C-22.5A-8V 22.5° Approach Angle Bars for Facing and Internal Machining

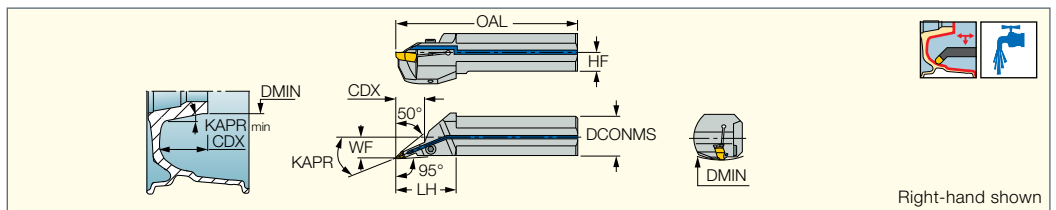

Right-hand shown

Designation	CW	DCONMS	DMIN	CDX	OAL	LH	HF	WF	KAPR			
GHIUR/L 40C-22.5A-8V	8.00	40.00	300.00	28.50	250.00	60.0	18.0	21.00	22.5	SR M6X20 DIN912	HW 5.0	PL 40

• Upper jaw with hard coating to sustain chip deflection

For inserts, see pages: GIPA 8-35V (V-shape) (409)

CUTGRIP

GHIUR/L-UC 45° Undercutting Bars for Internal Turning of Aluminum Wheels

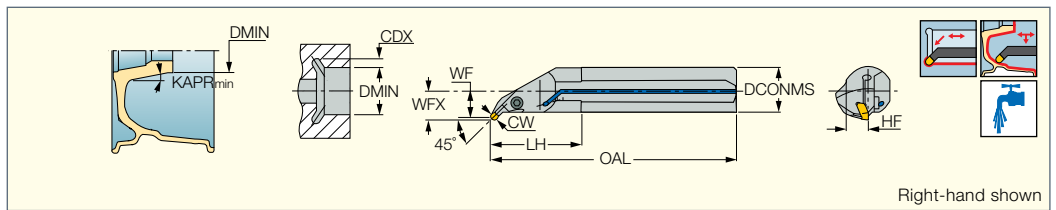

Right-hand shown

Designation	CW	DCONMS	DMIN	CDX	OAL	LH	WFX	WF	HF			
GHIUR/L 40UC-6	6.00	40.00	70.00	0.00 ⁽¹⁾	350.00	75.0	23.80	24.7	18.0	SR M6X20 DIN912	HW 5.0	PL 40
GHIUR/L 50UC-6	6.00	50.00	78.00	0.00 ⁽²⁾	350.00	75.0	28.80	29.7	23.0	SR M6X20 DIN912	HW 5.0	PL 40
GHIUR/L 40UC-8	8.00	40.00	68.00	0.00 ⁽³⁾	350.00	79.0	28.80	26.0	18.0	SR M6X20 DIN912	HW 5.0	PL 40
GHIUR/L 50UC-8	8.00	50.00	58.00	0.00 ⁽⁴⁾	350.00	80.0	30.20	31.4	23.0	SR M6X20 DIN912	HW 5.0	PL 40

⁽¹⁾ Cutting depth maximum

⁽²⁾ For bore diameter more than 200, CDX is 1.3 mm

⁽³⁾ For bore diameter more than 200, CDX is 2.0 mm

⁽⁴⁾ For bore diameter more than 200, CDX is 2.8 mm

For inserts, see pages: GDMA (284) • GIPA 8-35V (V-shape) (409) • GIPA/GIDA 8 (full radius) (286)

CUTGRIP

GHIFR/L-A 8° / 10° Approach Angle Bars for Facing and Internal Machining

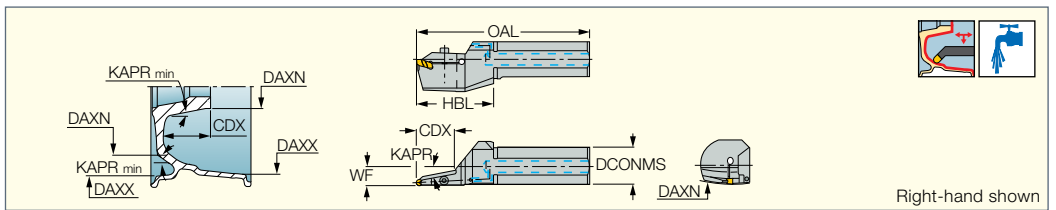

Right-hand shown

Designation	CW	DAXN ⁽¹⁾	DAXX ⁽²⁾	OAL	HBL	CDX	WF	KAPR	DCONMS			
GHIFR/L 40C-10A-6	6.00	300.00	360.0	300.00	80.0	40.00	19.30	10.0	40.00	SR M5X20DIN912	HW 4.0	PL 40
GHIFR/L 40C-8A-8	8.00	300.00	360.0	320.00	100.0	70.00	19.50	8.0	40.00	SR M6X25 DIN912	HW 5.0	PL 40

• Upper jaw with hard coating to sustain chip deflection

⁽¹⁾ Minimum axial grooving diameter

⁽²⁾ Maximum axial grooving diameter

For inserts, see pages: GDMA (284) • GIPA (full radius W=3-6) (285) • GIPA/GIDA 8 (full radius) (286)



CUTGRIP

GHDR/L-8A

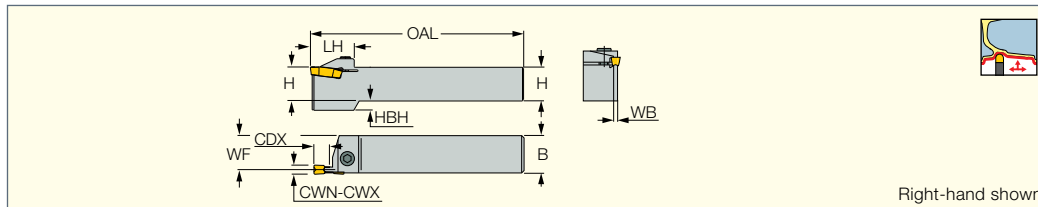
External Tools for Turning, Grooving and Parting; Upper Jaw with Hard Coating to Sustain Chip Deflection



Right-hand shown

Designation	H	CWN ⁽¹⁾	CWX ⁽²⁾	CDX	B	OAL	WF	WB	LH	HBH		
GHDR/L 25-8A	25.0	8.00	8.00	25.00	25.0	150.00	22.00	6.00	40.0	7.6	SR M6X16 DIN912	HW 5.0
GHDR/L 32-8A	32.0	8.00	8.00	25.00	32.0	170.00	29.00	6.00	40.0	-	SR M6X16 DIN912	HW 5.0

• Upper jaw with hard coating to sustain chip deflection • For user guide, see pages 380-395

⁽¹⁾ Minimum cutting width

⁽²⁾ Maximum cutting width

For inserts, see pages: GIPA/GIDA 8 (full radius) (286)



CUTGRIP

GHVR/L

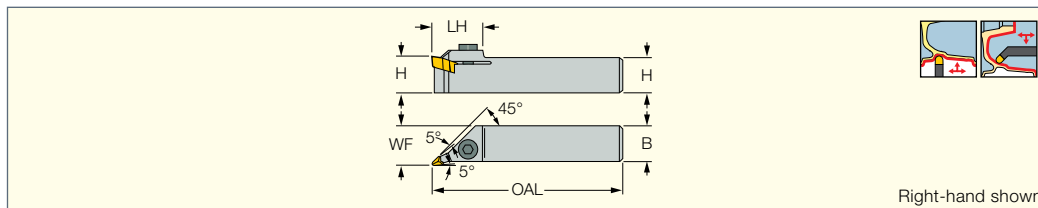
Internal and External Profiling Holders for Machining Aluminum Wheels



Right-hand shown

Designation	CW	H	B	OAL	WF	LH		
GHVR/L 25-8	8.00	25.0	25.0	150.00	29.00	41.0	SR M6X16 DIN912	HW 5.0

For inserts, see pages: GIPA 8-35V (V-shape) (409)



CUTGRIP

GHDKR/L

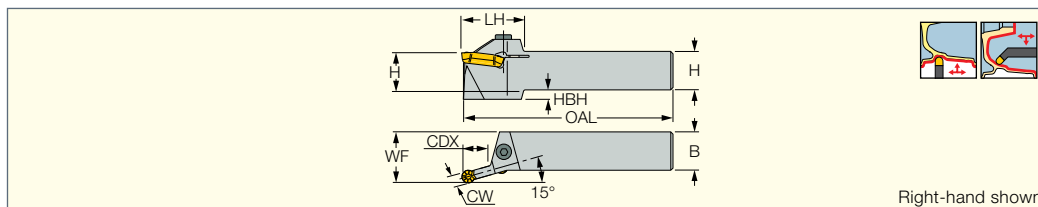
External and Internal Profiling Holders for Machining Aluminum Wheels



Right-hand shown

Designation	CW	H	B	OAL	LH	WF	HBH		
GHDKR/L 25-6 ⁽¹⁾	6.00	25.0	25.0	150.00	40.0	32.20	6.0	SR M6X20 DIN912	HW 5.0
GHDKR/L 25-8	8.00	25.0	25.0	150.00	44.0	33.00	6.0	SR M6X20 DIN912	HW 5.0
GHDKR/L 32-8	8.00	32.0	32.0	170.00	44.0	40.00	-	SR M6X20 DIN912	HW 5.0

⁽¹⁾ Only insert GIPA 6.00-3.00 is suitable for this tool.

For inserts, see pages: GDMA (284) • GDMY (full radius) (274) • GIPA (full radius W=3-6) (285) • GIPA/GIDA 8 (full radius) (286)

CUTGRIP

GIPA (full radius W=3-6)
Precision Double-Ended
Inserts with Polished Top Rake
for Machining Aluminum

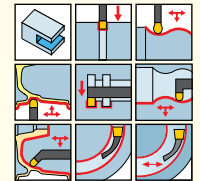
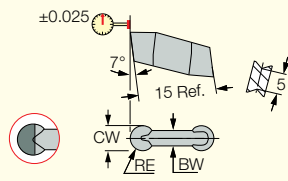
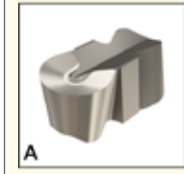

Designation	Dimensions					Tough ↔ Hard				Recommended Machining Data		
	CW	RE	CWTOL ⁽⁴⁾	RETOL ⁽⁵⁾	BW	IC20	IC806	IC4	ID5	a _p (mm)	f turn (mm/rev)	f groove (mm/rev)
GIPA 3.00-1.50	3.00	1.50	0.02	0.050	2.40	●				0.00-1.50	0.15-0.30	0.08-0.16
GIPA 3.00-1.50-D ⁽¹⁾	3.00	1.50	0.02	0.050	2.40				●	0.00-1.50	0.19-0.36	0.09-0.19
GIPA 3.00-1.50YZ-D ⁽²⁾	3.00	1.50	0.02	0.050	2.40				●	0.00-1.50	0.19-0.36	0.09-0.19
GIPA 4.00-2.00	4.00	2.00	0.02	0.050	3.20	●	●			0.00-2.00	0.20-0.43	0.10-0.22
GIPA 4.00-2.00-D ⁽¹⁾	4.00	2.00	0.02	0.050	3.20				●	0.00-2.00	0.25-0.53	0.12-0.26
GIPA 4.00-2.00YZ-D ⁽²⁾	4.00	2.00	0.02	0.050	3.20				●	0.00-2.00	0.25-0.53	0.12-0.26
GIPA 5.00-2.50	5.00	2.50	0.02	0.050	3.90	●	●			0.00-2.50	0.21-0.48	0.09-0.24
GIPA 5.00-2.50-D ⁽¹⁾	5.00	2.50	0.02	0.050	3.90				●	0.00-2.50	0.22-0.60	0.11-0.30
GIPA 5.00-2.50YZ-D ⁽²⁾	5.00	2.50	0.02	0.050	3.90				●	0.00-2.50	0.22-0.60	0.11-0.30
GIPA 6.00-3.00	6.00	3.00	0.02	0.050	4.80	●		●		0.00-3.00	0.21-0.58	0.11-0.29
GIPA 6.00-3.00-D ⁽¹⁾	6.00	3.00	0.02	0.050	4.80				●	0.00-3.00	0.26-0.72	0.13-0.36
GIPA 6.00-3.00YZ	6.00	3.00	0.02	0.050	4.80	●				0.00-3.00	0.21-0.58	0.11-0.29
GIPA 6.00-3.00YZ-D ⁽²⁾	6.00	3.00	0.02	0.050	4.80				●	0.00-3.00	0.26-0.72	0.13-0.36
GIPA 6.00-3.00CB ⁽³⁾	6.00	3.00	0.02	0.050	4.80				●	0.00-3.00	0.21-0.58	0.11-0.29

• For cutting speed recommendations and user guide, see pages 380-395

- ⁽¹⁾ Single-ended PCD tipped insert
- ⁽²⁾ Single-ended molded PCD chipformer tipped insert
- ⁽³⁾ Single-ended flat PCD tipped insert with chip deflector
- ⁽⁴⁾ Cutting width tolerance (+/-)
- ⁽⁵⁾ Corner radius tolerance (+/-)

For tools, see pages: Anti-Vibration Blades (268) • C#-GHDR/L (259) • CGHN 26-M (340) • CGHN 32-DGM (342) • CGHN 32-M (341) • CGHN-D (266) • CGHN-DG (267) • CGHN-S (266) • CGPAD (265) • CGPAD-JHP (265) • GHDKR/L (407) • GHDR/L (short pocket) (259) • GHDR/L-JHP (short pocket) (260) • GHDR/L-JHP-MC (short pocket) (261) • GHGR/L (262) • GHIFR/L-A (406) • GHIUR/L-C-A (15° & 27.5°) Bars (406) • GHMPR/L (258) • GHMR/L (258) • GHSR/L (357) • GHSR/L-JHP-SL (358)



CUTGRIP

GIPA/GIDA 8 (full radius)

Precision Double-Ended Inserts with Polished Top Rake for Machining Aluminum

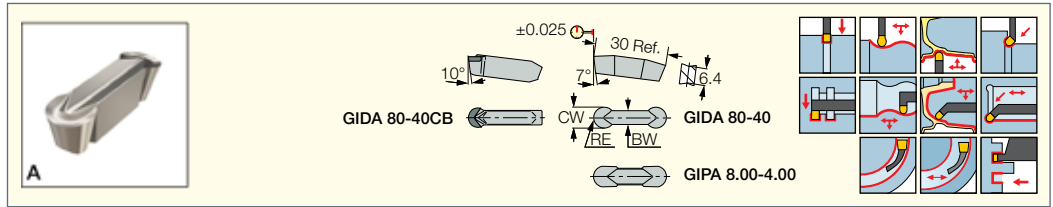

Designation	Dimensions					Tough ↔ Hard			Recommended Machining Data		
	CW	RE	CWTOL ⁽²⁾	RETOL ⁽³⁾	BW	IC20	IC4	ID5	a _p (mm)	f turn (mm/rev)	f groove (mm/rev)
GIDA 80-40	8.00	4.00	0.02	0.050	5.60	●	●		0.00-4.00	0.24-0.67	0.14-0.38
GIDA 80-40-D	8.00	4.00	0.02	0.050	5.60			●	0.00-4.00	0.24-0.67	0.14-0.38
GIDA 80-40CB-D ⁽¹⁾	8.00	4.00	0.02	0.050	5.60			●	0.00-4.00	0.24-0.67	0.14-0.38
GIDA 80-40YZ	8.00	4.00	0.02	0.050	5.60	●	●		0.00-4.00	0.24-0.67	0.14-0.38
GIDA 80-40YZ-D	8.00	4.00	0.02	0.050	5.60			●	0.00-4.00	0.35-0.96	0.18-0.48
GIPA 8.00-4.00	8.00	4.00	0.02	0.050	6.00	●			0.00-4.00	0.24-0.67	0.14-0.38

• ID5 is a single-ended PCD tipped insert • For cutting speed recommendations and user guide, see pages 380-395

⁽¹⁾ Should not be clamped on tools with "A" suffix

⁽²⁾ Cutting width tolerance (+/-)

⁽³⁾ Corner radius tolerance (+/-)

For tools, see pages: C#-GHDR/L (259) • CGHN-8-10D (270) • GADR/L-8 (269) • GADR/L-JHP (270) • GAFG-R/L-8 (562) • GHDKR/L (407) • GHDR/L (long pocket) (268) • GHDR/L-8A (407) • GHDR/L-JHP (long pocket) (268) • GHFR/L-8 (561) • GHFR/L-A (406) • GHIR/L (W=7.0-8.3) (339) • GHIUR/L-C-A (15° & 27.5°) Bars (406) • GHIUR/L-UC (406)

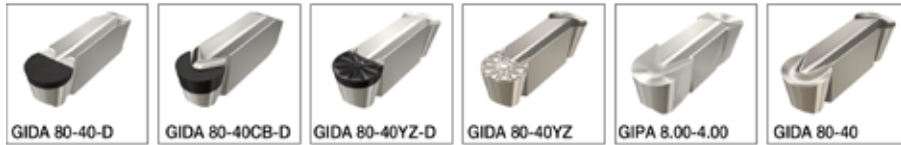

CUTGRIP

GIPA 8-35V (V-shape)

V-Shaped Inserts for Machining Aluminum Wheels

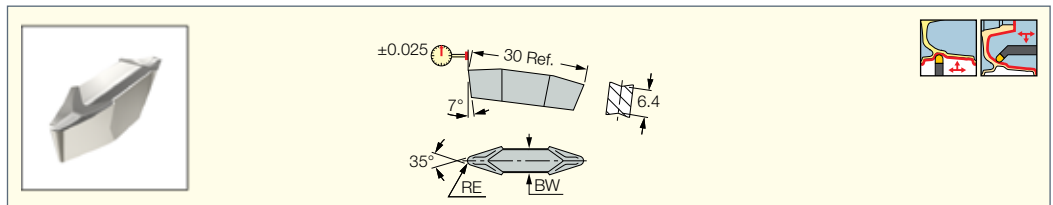

Designation	Dimensions			Tough ↔ Hard			Recommended Machining Data	
	RE	RETOL ⁽²⁾	BW	IC20	IC4	ID5	a _p (mm)	f turn (mm/rev)
GIPA 6.0-35V-0.8	0.80	0.050	4.80	●			1.00-3.60	0.21-0.48
GIPA 8YZ-35V-0.80	0.80	0.050	6.00		●		1.00-4.80	0.24-0.56
GIPA 8YZ-35V-1.20	1.20	0.050	6.00		●		1.45-4.80	0.24-0.62
GIPA 8YZ-35V-1.20-D ⁽¹⁾	1.20	0.050	6.00			●	1.45-4.80	0.35-0.88
GIPA 8-35V-1.20	1.20	0.050	6.00	●			1.45-4.80	0.24-0.62
GIPA 8-35V-1.20-D ⁽¹⁾	1.20	0.050	6.00			●	1.45-4.80	0.35-0.88
GIPA 8-35V-3.0	3.00	0.050	6.00	●	●		3.60-4.80	0.24-0.67

• Precision ground and polished rake to avoid built-up edge • Toolholder seat needs to be modified according to insert profile to ensure clearance

⁽¹⁾ Single-ended PCD tipped insert

⁽²⁾ Corner radius tolerance (+/-)

For tools, see pages: GHIUR/L-C-22.5A-8V (406) • GHIUR/L-C-A (15° & 27.5°) Bars (406) • GHIUR/L-UC (406) • GHVR/L (407)

CUTGRIP

GDMA

Utility Double-Ended Insert with a Polished Top Rake for Machining Aluminum

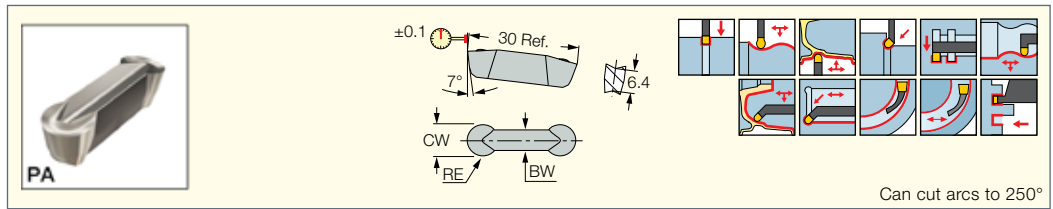

Designation	Dimensions					Tough ↔ Hard		Recommended Machining Data		
	CW	RE	CWTOL ⁽¹⁾	RETOL ⁽²⁾	BW	IC07	IC507	a _p (mm)	f turn (mm/rev)	f groove (mm/rev)
GDMA 840	8.00	4.00	0.05	0.050	5.60	●	●	0.00-4.00	0.24-0.67	0.14-0.38

• For heavy-duty machining • DMIN for internal machining = 65 mm • For cutting speed recommendations and user guide, see pages 380-395

⁽¹⁾ Cutting width tolerance (+/-)

⁽²⁾ Corner radius tolerance (+/-)

For tools, see pages: GADR/L-8 (269) • GADR/L-JHP (270) • GAFG-R/L-8 (562) • GHDKR/L (407) • GHIFR/L-A (406) • GHIR/L (W=7.0-8.3) (339) • GHIUR/L-C-A (15° & 27.5°) Bars (406) • GHIUR/L-UC (406)

FIXGRIP

FSHIUR

10° / 15° Approach Angle Bars for Facing and Internal Profiling of Aluminum

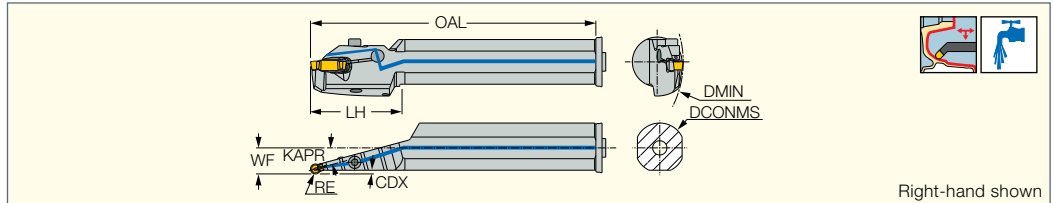

Designation	CW	DCONMS	DMIN	OAL	LH	CDX	WF	KAPR					
FSHIUR 40C-15A-6	6.00	40.00	160.00	320.00	68.0	2.20	21.00	15.0	SR M6X1-28509	HW 5.0	OR 5X1N	PU SEAL-28510	PL 40
FSHIUR 40C-10A-8	8.00	40.00	160.00	320.00	68.0	2.40	24.30	10.0	SR M6X1-28509	HW 5.0	OR 5X1N	PU SEAL-28510	PL 40
FSHIUR 40C-15A-8	8.00	40.00	160.00	320.00	68.0	3.00	21.00	15.0	SR M6X1-28509	HW 5.0	OR 5X1N	PU SEAL-28510	PL 40

• Clamping torque for FSHIUR..-6: 9 Nxm, for FSHDR..-8: 10.5 Nxm

For inserts, see pages: FSP/MA (411)

Insert Clamping Instructions

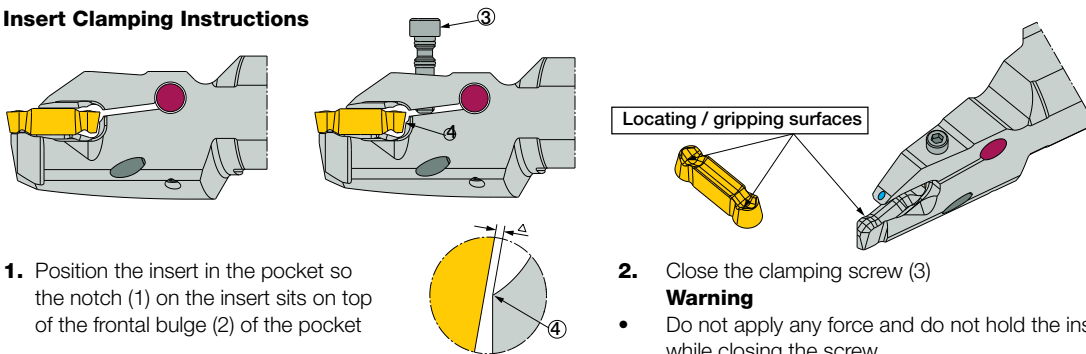

1. Position the insert in the pocket so the notch (1) on the insert sits on top of the frontal bulge (2) of the pocket

2. Close the clamping screw (3)



Warning

- Do not apply any force and do not hold the insert in place while closing the screw
- There is no contact between the insert and pocket rear wall (4)

FSHDR

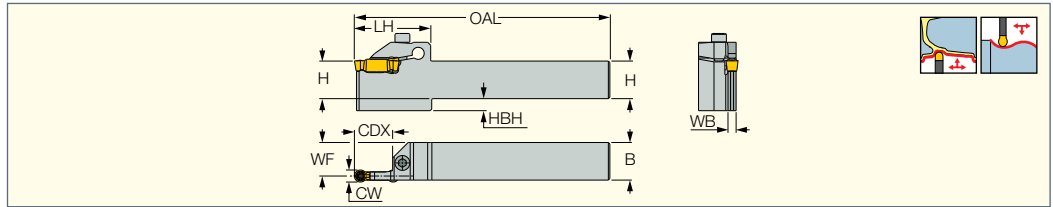
Tools with a Very Strong Insert Grip for Interrupted Cuts and Back Turning of Aluminum Wheels



Designation	CW	CDX	H	B	WF	WB	LH	HBH	OAL		
FSHDR 25-6	6.00	21.00	25.0	25.0	22.80	4.40	51.0	8.0	150.00	SR M5X20DIN912	HW 4.0
FSHDR 25-8	8.00	25.50	25.0	25.0	22.30	5.40	51.5	8.0	170.00	SR M6X25 DIN912	HW 5.0

• Clamping torque for FSHDR...-6: 7.5 Nxm, for FSHDR...-8: 10 Nxm

For inserts, see pages: FSP/MA (411)

Insert Clamping Instructions

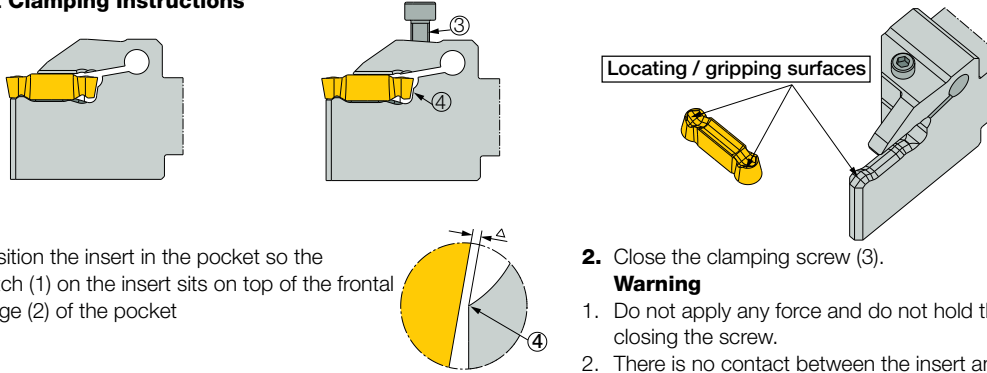

1. Position the insert in the pocket so the notch (1) on the insert sits on top of the frontal bulge (2) of the pocket

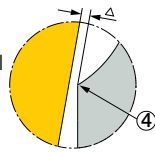

2. Close the clamping screw (3).

Warning

1. Do not apply any force and do not hold the insert in place while closing the screw.
2. There is no contact between the insert and pocket rear wall (4)

FSP/MA

Full Radius Precision Inserts for Machining Aluminum at Medium to High Feeds

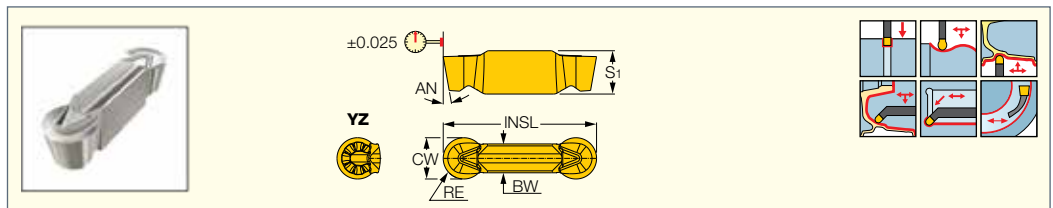

Designation	Dimensions							Tough ↔ Hard			Recommended Machining Data	
	CW	CWTOL ⁽²⁾	RE	S ₁	BW	INSL	AN	IC20	IC07	ID5	a _p (mm)	f _{turn} (mm/rev)
FSPA 6.00-3.00	6.00	0.02	3.00	7.50	4.60	25.00	9.0	●			0.05-3.00	0.30-0.55
FSPA 6.00-3.00YZ	6.00	0.02	3.00	7.50	4.60	25.00	9.0	●			0.05-3.00	0.30-0.55
FSPA 6.00-3.00YZ-D	6.00	0.02	3.00	7.50	4.60	25.00	9.0			●	0.05-3.00	0.30-0.55
FSMA 80-40 ⁽¹⁾	8.00	0.04	4.00	8.40	5.60	29.70	10.0		●		0.05-4.00	0.40-0.72
FSPA 80-40	8.00	0.02	4.00	8.40	5.60	29.70	10.0	●			0.05-4.00	0.40-0.72
FSPA 80-40-D	8.00	0.02	4.00	8.40	5.60	29.70	10.0			●	0.05-4.00	0.40-0.72
FSPA 80-40YZ	8.00	0.02	4.00	8.40	5.60	29.70	10.0	●			0.05-4.00	0.40-0.72
FSPA 80-40YZ-D	8.00	0.02	4.00	8.40	5.60	29.70	10.0			●	0.05-4.00	0.40-0.72

⁽¹⁾ Utility insert

⁽²⁾ Cutting width tolerance (+/-)

For tools, see pages: FSHDR (411) • FSHIUR (410)



FIXGRIP

FGHDUR

Tools for Interrupted Cuts and Back Turning of Aluminum Wheels

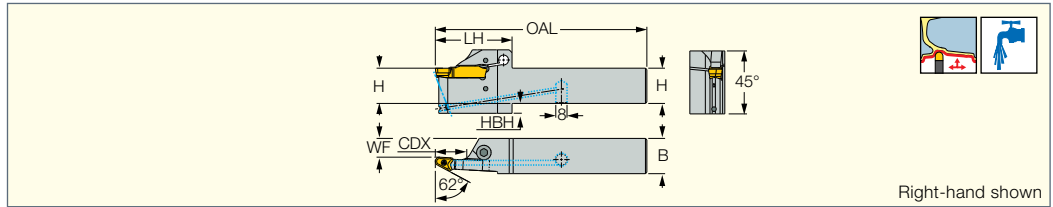

Right-hand shown

Designation	CDX	H	B	OAL	WF	LH	HBH		
FGHDUR 25C-3A-10S	22.30	25.0	25.0	150.00	13.30	54.4	7.0	SR M6X25 DIN912	HW 5.0

• Upper jaw with hard coating to sustain chip deflection • For mounting and removing the inserts, see page 380-395
 For inserts, see pages: FGPAM (412)

FIXGRIP

FGPAM

V-Shaped Inserts for Machining Aluminum Wheels

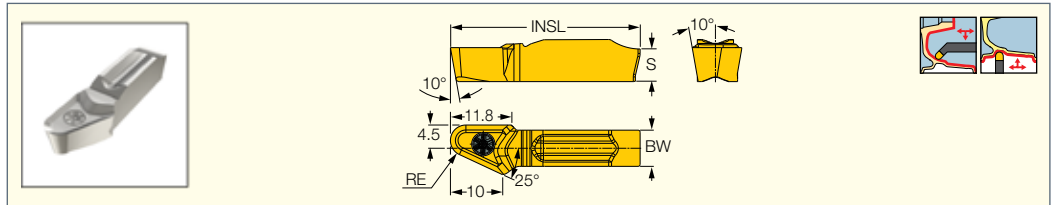

Designation	Dimensions					IC20	Recommended Machining Data	
	RE	BW	S	INSL	a_p (mm)		f turn (mm/rev)	
FGPAM 10S-3R-25A	3.00	7.00	8.20	36.50	•	0.05-12.00	0.40-0.72	

For tools, see pages: FGHDUR (412)

ISOTURN

SVJCR/L

93° Lead Angle Screw Lock Tools Carrying the 35° Diamond Inserts with 7° Clearance Angle

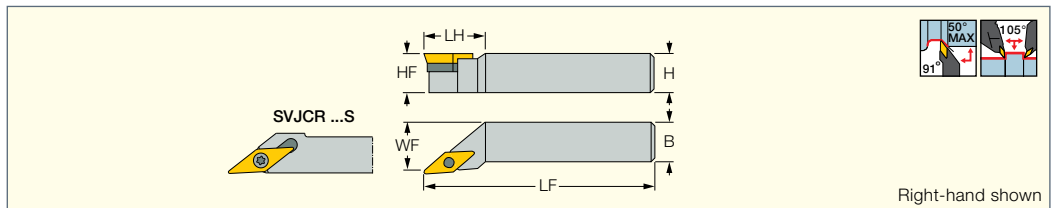

Right-hand shown

Designation	H	HF	B	LF	LH	WF	GAMP	GAMF	Insert					
SVJCR/L 0808K-11S (1)	8.0	8.0	8.0	125.00	11.5	8.20	0	0	VC..1103	SR 14-560	T-8/5			
SVJCR/L 1010K-11S (1)	10.0	10.0	10.0	125.00	22.0	10.20	0	0	VC..1103	SR 14-560	T-8/5			
SVJCR/L 1212K-11S (1)	12.0	12.0	12.0	125.00	-	12.20	0	0	VC..1103	SR 14-560	T-8/5			
SVJCR/L 1616K-11	16.0	16.0	16.0	125.00	25.0	20.00	0	0	VC..1103	SR 14-560	T-8/5			
SVJCR/L 2020K-11	20.0	20.0	20.0	125.00	30.0	25.00	0	0	VC..1103	SR 14-560	T-8/5			
SVJCR/L 2525M-11	25.0	25.0	25.0	150.00	30.0	32.00	0	0	VC..1103	SR 14-560	T-8/5			
SVJCR/L 2020K-16	20.0	20.0	20.0	125.00	30.0	25.00	0	0	VC..1604	SR 16-236 P	T-15/5	TVC 3-1	SR TC-3	HW 2.5
SVJCR/L 2525M-16	25.0	25.0	25.0	150.00	30.0	32.00	0	0	VC..1604	SR 16-236 P	T-15/5	TVC 3-1	SR TC-3	HW 2.5

(1) For Swiss-type machines

ISOTURN JETCUT

SVJCR/L-16-JHP

Screw Lock Tools with Channels for High Pressure Coolant Carrying 35° Rhombic Inserts with 7° Clearance Angle

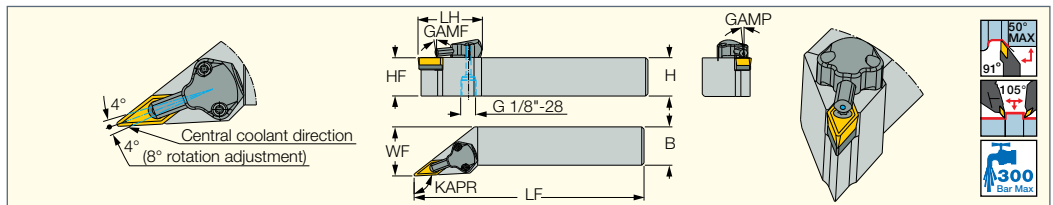

Designation	H	B	HF	LF	LH	WF	KAPR	GAMP	GAMF	Insert
SVJCR/L 2525M-16-JHP	25.0	25.0	25.0	150.00	42.0	32.00	93.0	0	0	VCMT 1604

• For user guide, see pages 380-400

Spare Parts

Designation							
SVJCR/L 2525M-16-JHP	TVC 3-1	SR TC-3	SR 16-236 P	CU-V-JHP	T-15/5	HW 2.5	T-8/5

ISOTURN

SVVCN

72.5° Lead Angle Screw Lock Tools Carrying the 35° Diamond Inserts with 7° Clearance Angle

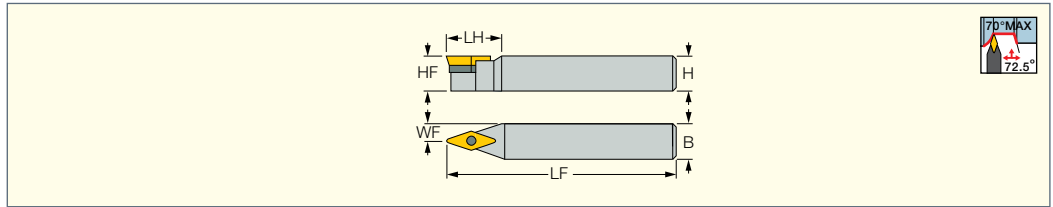

Designation	H	HF	B	LF	LH	WF	GAMP	GAMF	Insert					
SVVCN 0808K-11S ⁽¹⁾	8.0	8.0	8.0	125.00	-	4.30	0	0	VC..1103	SR 14-560	T-8/5			
SVVCN 1010K-11S ⁽¹⁾	10.0	10.0	10.0	125.00	-	5.30	0	0	VC..1103	SR 14-560	T-8/5			
SVVCN 1212K-11S ⁽¹⁾	12.0	12.0	12.0	125.00	-	6.30	0	0	VC..1103	SR 14-560	T-8/5			
SVVCN 1616K-11S ⁽¹⁾	16.0	16.0	16.0	125.00	-	8.30	0	0	VC..1103	SR 14-560	T-8/5			
SVVCN 2020K-16	20.0	20.0	20.0	125.00	34.0	10.00	0	0	VC..1604	SR 16-236 P	T-15/5	TVC 3-1	SR TC-3	HW 2.5
SVVCN 2525M-16	25.0	25.0	25.0	150.00	38.1	12.50	0	0	VC..1604	SR 16-236 P	T-15/5	TVC 3-1	SR TC-3	HW 2.5

⁽¹⁾ For Swiss-type machines

ISOTURN

SVXCR/L

112° Lead Angle Screw Lock Tools Carrying the 35° Diamond Inserts with 7° Clearance Angle

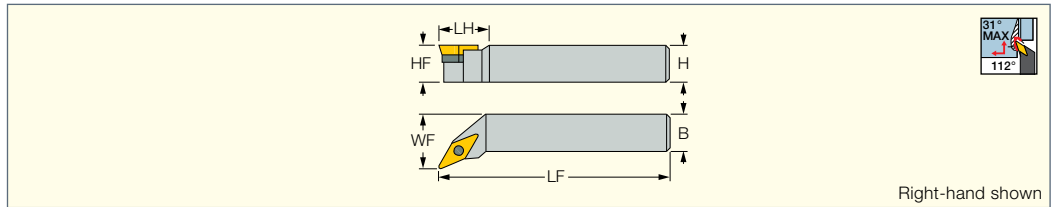

Designation	H	HF	B	LF	LH	WF	GAMP	GAMF	Insert					
SVXCR/L 2020K-16	20.0	20.0	20.0	125.00	25.0	25.00	0	0	VC..1604	TVC 3-1	SR TC-3	HW 2.5	SR 16-236 P	T-15/5
SVXCR/L 2525M-16	25.0	25.0	25.0	150.00	30.0	32.00	0	0	VC..1604	TVC 3-1	SR TC-3	HW 2.5	SR 16-236 P	T-15/5

Right-hand shown

ISOTURN

A/S-SVQCR/L

Screw Lock Boring Bars Carrying the 35° Rhombic Inserts with 7° Clearance

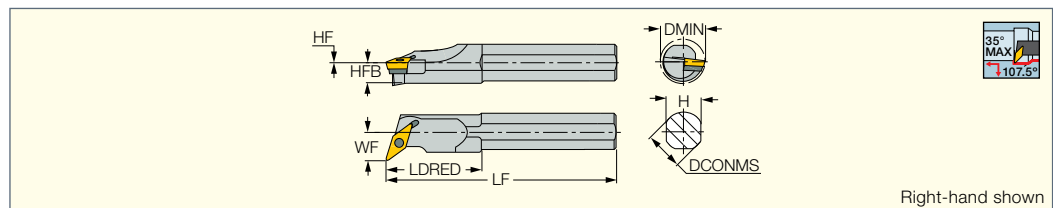

Designation	DCONMS	LF	LDRED	H	HFB	WF	HF	DMIN	GAMP	GAMF	CSP ⁽¹⁾	Insert
S25S SVQCR/L-16	25.00	250.00	61.0	23.0	12.0	17.00	0.5	32.00	0	-5	0	VC.. 1604
S32T SVQCR/L-16	32.00	300.00	70.0	30.0	15.0	22.00	0.0	40.00	0	-5	0	VC.. 1604
A40U SVQCR/L-22	40.00	350.00	64.0	36.0	18.0	27.00	0.0	47.50	0	-8	1	VCGT 2205

⁽¹⁾ 0 - Without coolant supply, 1 - With coolant supply

For inserts, see pages: VCMT-FPC-CERMET (175) • VCMT-F3P (174) • VCGW-2 (CBN) (211) • VCMT-F3M (174) • VCMT-M3M (174) • VCMT-SM (176) • VCGT-AS (190) • VCGT-AF (190) • VCMT-14 (176) • VCMW (176) • VCMT (CBN) (202) • VCGT (PCD) (202) • VCGT-DW (PCD) (202)

Spare Parts

Designation								
S25S SVQCR/L-16	SR 16-236 P	T-15/5						
S32T SVQCR/L-16	SR 16-236 P	T-15/5	TVC 3-1P	SR TC-3P	HW 4.0			
A40U SVQCR/L-22	SR 14-536	T-20/5	TVC 22T330	SR TC-3	HW 2.5			PL 40

ISOTURN

**A/S-SVLFCR/L;
A-SVUCR/L**

Screw Lock Boring Bars
Carrying the 35° Rhombic
Inserts with 7° Clearance

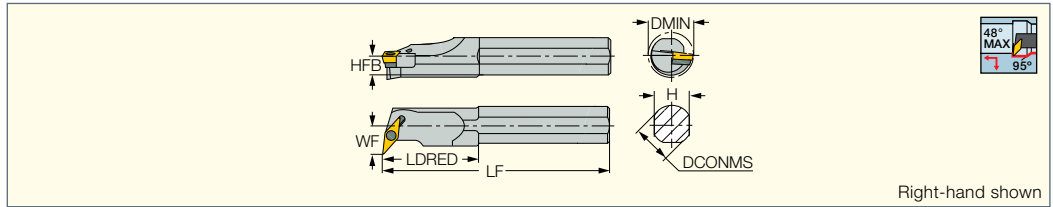

Right-hand shown

Designation	DCONMS	LF	LDRED	H	HFB	WF	DMIN	GAMP	GAMF	CSP ⁽²⁾	Insert
A32T SVUCR/L-16 ⁽¹⁾	32.00	300.00	50.0	29.0	14.5	22.00	40.00	0	-8	1	VC.. 1604
S32T SVLFCR/L-16	32.00	300.00	56.0	29.0	14.5	22.00	39.50	0	-8	0	VC.. 1604
S40U SVLFCR/L-16	40.00	350.00	-	36.0	18.0	27.00	49.00	0	-5	0	VC.. 1604
A40U SVLFCR/L-22	40.00	350.00	70.0	36.0	18.0	27.00	48.00	0	-8	1	VC.. 2205

⁽¹⁾ 93° approach angle

⁽²⁾ 0 - Without coolant supply, 1 - With coolant supply

For inserts, see pages: VCMT-F3P (174) • VCMT-F3M (174) • VCMT-M3M (174) • VCMT-SM (176) • VCGT-AS (190) • VCGT-AF (190) • VCMT-14 (176) • VCMW (176) • VCMT (CBN) (202) • VCGT (PCD) (202) • VCGT-DW (PCD) (202) • VCMT-FPC-CERMET (175) • VCGW-2 (CBN) (211)

Spare Parts

Designation							
A32T SVUCR/L-16	TVC 3-1P	SR TC-3P	HW 1.5	HW 4.0	SR 16-236 P	PL 32	T-15/5
S32T SVLFCR/L-16	TVC 3-1P	SR TC-3P	HW 4.0	HW 4.0	SR 16-236 P		T-15/5
S40U SVLFCR/L-16	TVC 3-1P	SR TC-3P	HW 4.0	HW 4.0	SR 16-236 P		T-15/5
A40U SVLFCR/L-22	TVC 22T330	SR TC-3	HW 2.5	HW 2.5	SR 14-536	PL 40	T-20/5

ISOTURN

A/S-SVLBCR/L

Screw Lock Back Boring Bars
Carrying the 35° Rhombic
Inserts with 7° Clearance

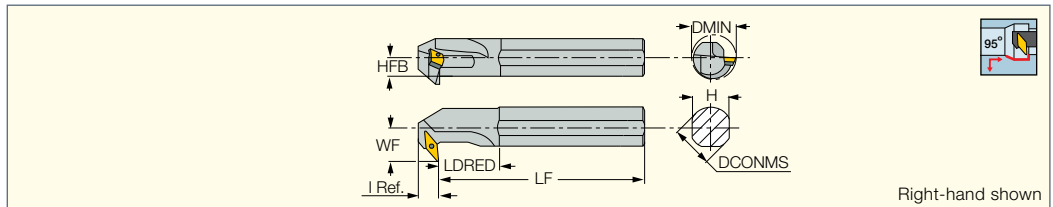

Right-hand shown

Designation	DCONMS	LF	LDRED	I Ref.	H	HFB	WF	DMIN	GAMP	GAMF	CSP ⁽¹⁾	Insert
A32T SVLBCR/L-16	32.00	300.00	76.5	18.50	29.0	14.5	27.50	40.00	0	-8	1	VC.. 1604
S32T SVLBCR/L-16	32.00	300.00	63.2	18.50	29.0	14.5	22.00	40.00	0	-8	0	VC.. 1604
S40U SVLBCR/L-16	40.00	350.00	60.0	20.00	36.0	18.0	27.00	49.50	0	-5	0	VC.. 1604

⁽¹⁾ 0 - Without coolant supply, 1 - With coolant supply

For inserts, see pages: VCMT-FPC-CERMET (175) • VCMT-F3P (174) • VCGW-2 (CBN) (211) • VCMT-F3M (174) • VCMT-M3M (174) • VCMT-SM (176) • VCGT-AS (190) • VCMT-14 (176) • VCMW (176) • VCMT (CBN) (202) • VCGT (PCD) (202) • VCGT-DW (PCD) (202)

Spare Parts

Designation					
A/S-SVLBCR/L	TVC 3-1P	SR TC-3P	HW 4.0	SR 16-236 P	T-15/5

ISOTURN

VCGT-AS

35° Rhombic Inserts with a 7°
Positive Flank, Very Positive
Rake Angle and Sharp Cutting
Edge for Machining Aluminum

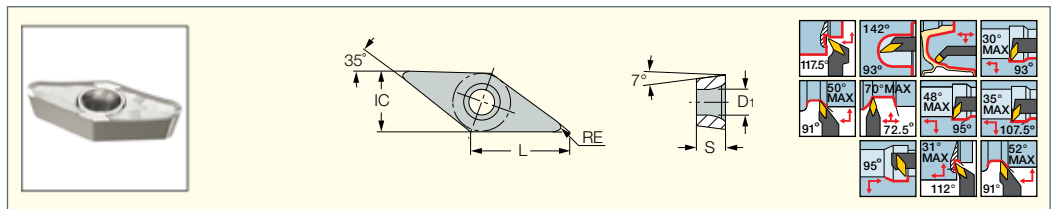

Designation	Dimensions					Tough ↔ Hard		Recommended Machining Data	
	L	IC	S	RE	D ₁	IC920	IC20	a _p (mm)	f (mm/rev)
VCGT 110302-AS	11.10	6.35	3.18	0.20	2.90	●	●	0.20-2.50	0.05-0.20
VCGT 110304-AS	11.10	6.35	3.18	0.40	2.90	●	●	0.50-3.00	0.05-0.25
VCGT 160401-AS	16.60	9.52	4.76	0.10	4.40	●	●	0.20-2.50	0.05-0.20
VCGT 160402-AS	16.60	9.52	4.76	0.20	4.40	●	●	0.50-2.50	0.05-0.25
VCGT 160404-AS	16.60	9.52	4.76	0.40	4.40	●	●	0.50-3.00	0.05-0.25
VCGT 160408-AS	16.60	9.52	4.76	0.80	4.40	●	●	0.50-3.00	0.10-0.25
VCGT 160412-AS	16.60	9.52	4.76	1.20	4.40	●	●	0.50-3.00	0.10-0.25
VCGT 220530-AS	22.10	12.70	5.56	3.00	5.50	●	●	1.50-4.50	0.15-0.30

• For user guide and cutting speed recommendations, see pages 380-395

ISOTURN

VCGT-AF

Inserts with a Very Positive Rake Angle and Sharp Cutting Edge for Semi-Finishing and Finishing on Aluminum

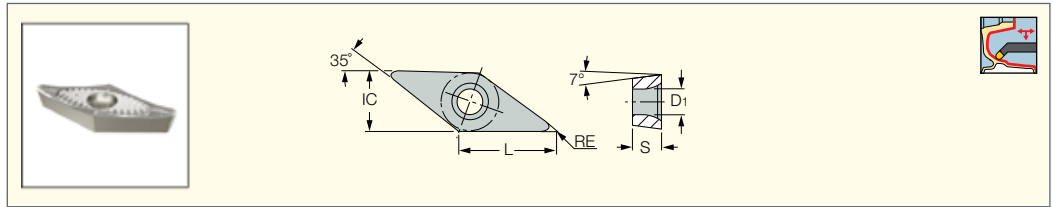

Designation	Dimensions						IC20	Recommended Machining Data	
	L	IC	S	RE	D1	a_p (mm)		f (mm/rev)	
VCGT 220508-AF	22.10	12.70	5.56	0.80	5.50	●	1.00-4.50	0.10-0.25	
VCGT 220512-AF	22.10	12.70	5.56	1.20	5.50	●	1.00-4.50	0.10-0.30	
VCGT 220516-AF	22.10	12.70	5.56	1.60	5.50	●	1.50-4.50	0.10-0.35	

• For user guide and cutting speed recommendations, see pages 380-395

ISOTURN

VCGT-DW (PCD)

Inserts with 7° Clearance and a Single PCD Top Corner Tip Chipformer for Machining Aluminum

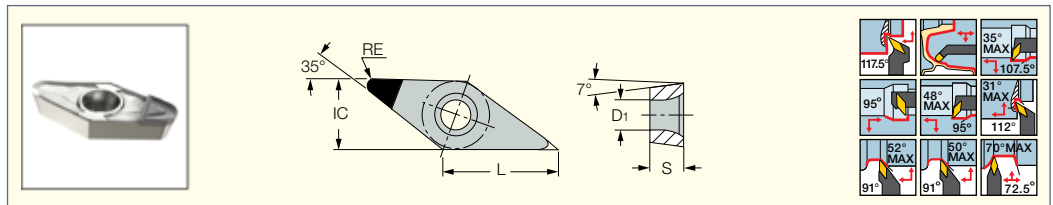

Designation	Dimensions						ID5	Recommended Machining Data	
	L	IC	S	RE	D1	a_p (mm)		f (mm/rev)	
VCGT 160404-DW	16.60	9.52	4.76	0.40	4.40	●	0.10-3.00	0.05-0.30	
VCGT 160408-DW	16.60	9.52	4.76	0.80	4.40	●	0.10-3.00	0.05-0.30	
VCGT 160412-DW	16.60	9.52	4.76	1.20	4.40	●	0.10-3.00	0.05-0.30	
VCGT 220516-DW	22.10	12.70	5.56	1.60	5.50	●	0.10-3.00	0.05-0.30	
VCGT 220520-DW	22.10	12.70	5.56	2.00	5.50	●	0.10-3.00	0.05-0.30	
VCGT 220530-DW	22.10	12.70	5.56	3.00	5.50	●	0.10-3.00	0.05-0.30	

• For user guide and cutting speed recommendations, see pages 380-395

ISOTURN

VCGT (PCD)

35° Rhombic Single Brazed Tip Corner Inserts for Finishing Aluminum (PCD)

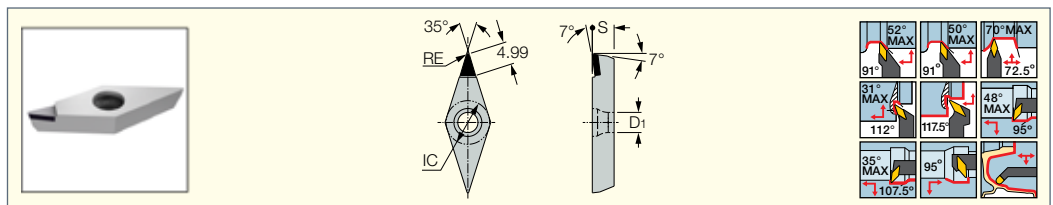

Designation	Dimensions						ID5	Recommended Machining Data	
	IC	S	RE	L	D1	a_p (mm)		f (mm/rev)	
VCGT 160404D	9.52	4.76	0.40	16.60	4.40	●	0.10-3.00	0.05-0.30	
VCGT 160408D	9.52	4.76	0.80	16.60	4.40	●	0.10-3.00	0.05-0.30	

• For user guide and cutting speed recommendations, see pages 380-395

ISOTURN JETCUT

SVHNR/L-JHP

Screw Lock Tools with Channels for High Pressure Coolant Carrying 35° Rhombic Inserts

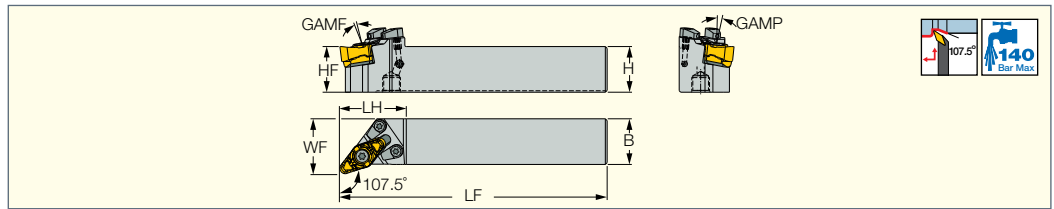

Designation	H	B	HF	LF	LH	WF	GAMP	GAMF	Insert
SVHNR/L 2525M-22-AL-JHP	25.0	25.0	25.0	146.34	36.4	30.03	7.0	6.0	VNGU 22..

• For user guide, see pages 380-400

Spare Parts

Designation							
SVHNR/L-JHP	TVX 2230	SR 14-591/L-SN	SW6-T-SH	BLD T20/S7	HW 3.0	SR TC-4	CH-1.9D-JHP-A SET

ISOTURN JETCUT

SVVNN-JHP

Screw Lock Tools with Channels for High Pressure Coolant Carrying 35° Rhombic Inserts

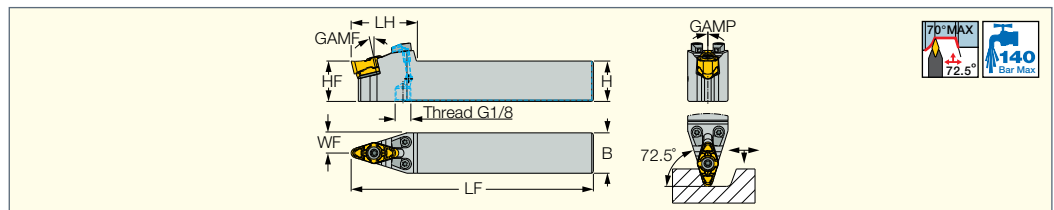

Designation	H	HF	B	LF	LH	WF	GAMP	GAMF	MIID ⁽¹⁾
SVVNN 2525M-22-AL-JHP	25.0	25.0	25.0	150.00	41.0	12.50	0	-13.5	VNGU 220630-R3N

⁽¹⁾ Master insert identification

For inserts, see pages: VNGU-R3N (189)

Spare Parts

Designation							
SVVNN-JHP	TVX 2230	HW 3.0	BLD T20/S7	SW6-T-SH	SR TC-4	SR 14-591/L-SN	CH-1.9D-JHP-A SET

ISOTURN

A-SVQNR/L-AL-JHP

Screw Lock Boring Bars Carrying the 35° Rhombic Inserts

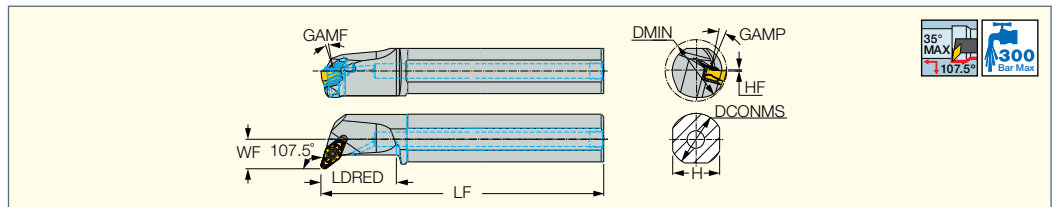

Designation	DCONMS	LF	LDRED	H	HF	WF	DMIN	GAMP	GAMF	Insert
A40U SVQNR/L-22-AL-JHP	40.00	348.10	60.0	36.0	0.1	23.40	49.00	6.5	14.5	VNGU 22..

Spare Parts

Designation							
A-SVQNR/L-AL-JHP	TVX 2230	SR 14-591/L-SN	HW 3.0	SW6-T-SH	BLD T20/S7	PL 40	SR TC-4

ISOTURN

VNGU-R3N

Double-Sided Sharp-Edged Positive Rake Inserts for Rough Machining on Aluminum and Other Non-Ferrous Materials

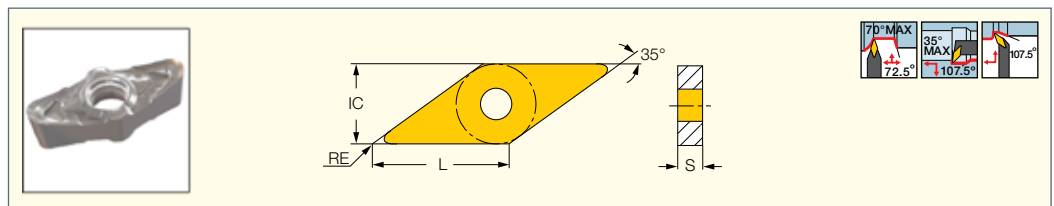

Designation	Dimensions					Recommended Machining Data		
	L	IC	S	RE	IC20	a _p (mm)	f (mm/rev)	
VNGU 220616-R3N	22.00	12.70	6.35	1.60	•	0.50-3.00	0.10-0.25	
VNGU 220630-R3N	22.00	12.70	6.35	3.00	•	1.50-4.50	0.15-0.30	

• For user guide and cutting speed recommendations, see pages 380-395

PARTING



TABLE OF CONTENTS

Selection Guide	419
Tools and Inserts	
DO-GRIP	425
TANG-GRIP	450
MULTI-F-GRIP	468
LOGIQ-5-GRIP	471
CUT-GRIP	473
PENTA-IQ-GRIP	476
PENTACUT R/L Parting Inserts	480
Full range of PENTACUT Tools & Inserts	295
User Guide	484
Modular Adaptations	494

Clamping Systems

DO-GRIP

- First choice for parting
- Double-ended insert
- Self clamped for deeper grooving and parting medium to large diameters
- Screw clamped for small diameters
- See also **HELI-GRIP**, page 243

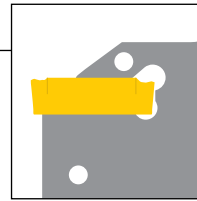
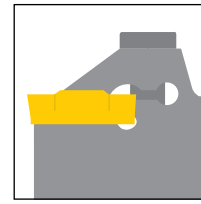
FIRST CHOICE!**Self-clamped****Screw-clamped****TANG-GRIP**

- Very rigid clamping in a tangentially oriented pocket
- Enables machining at very high feed rates and provides excellent straightness and surface finish
- Recommended for parting large diameter parts and for interrupted cuts
- Offers a free, unobstructed chip flow

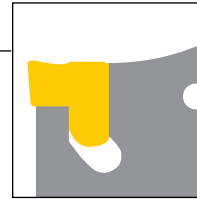
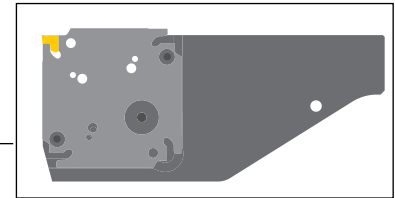
**TANG-GRIP****MULTI-F-GRIP****MULTI-F-GRIP**
HIGH FEED GRIP HOLDER

- Unique adaptation for Quad /Square type adapters with 4 pockets
- Outstanding stability, vibration free parting system also on big diameters
- Improves inserts life, surface finish and workpiece straightness due to robust design
- Enables reduction of cutting width due to excellent stability, leading to material savings
- **Ø120mm** bar can be cut with only 3 mm insert width
- Guarantees high productivity, especially when using **TAG N...HF** inserts with feed of up to 0.4 mm/rev.
- Economical adapters with 4 pockets
- User friendly, easy to operate
- Saves set up time after pocket replacement - adapter can be positioned with new pocket without set up
- Several adapters can be clamped on one tool block
- The tools and adapters are designed for **JET-CUT** cooling up to 140 Bar

LOGIQ5GRIP
PARTING & GROOVING

- Economical pentagonal adapters with 5 pockets
- No setup time after pocket replacement
- Several adapters can be clamped on one holder
- The tools and adapters are designed for **JET-CUT** cooling up to 340 Bar

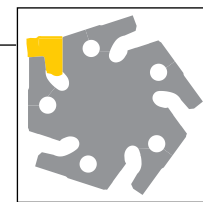
**LOGIQ-5-GRIP****CUT-GRIP**

- Single-ended insert
- Self- and screw-clamped options

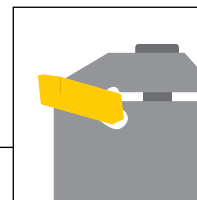
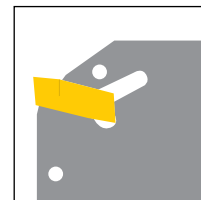
**Screw-clamped****Self-clamped****PENTACUT**

- 5 cutting edges
- Fast edge indexing
- For shallow grooving and up to 20 mm parting diameter
- **PENTAIQ** for parting up to 40mm bar diameter

**PENTACUT****PENTAIQ**

Main Chipformers

HF-Type

- For high feed machining only!
- Reinforced cutting edge (negative rake)
- Should be used with short extension tools

$$f \approx \frac{W_{insert}}{12} \text{ [mm/rev]}$$

Alloy Steel	Austenitic Stainless	High Temp. Alloys	Nonferrous Materials	Cast Iron
✓	✗	✗	✗	✓

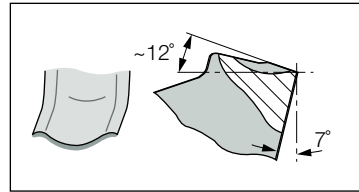

Recommended feed range as a function of insert width

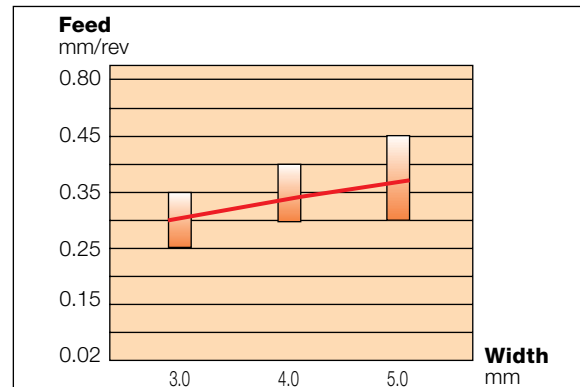

C-Type

- First choice for parting of bars, hard materials and tough applications.
- A positive rake, single cavity with negative land and shoulders provides extra cutting-edge strength.
- Medium-to-high feed

$$f \approx \frac{W_{insert}}{18} \text{ [mm/rev]}$$

Alloy Steel	Austenitic Stainless	High Temp. Alloys	Nonferrous Materials	Cast Iron
✓	✗	✓ (IC20 only)	✓ (IC20 only)	✓

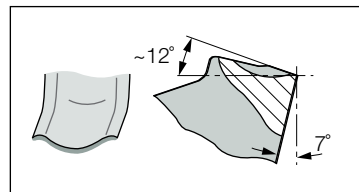

Recommended feed range as a function of insert width

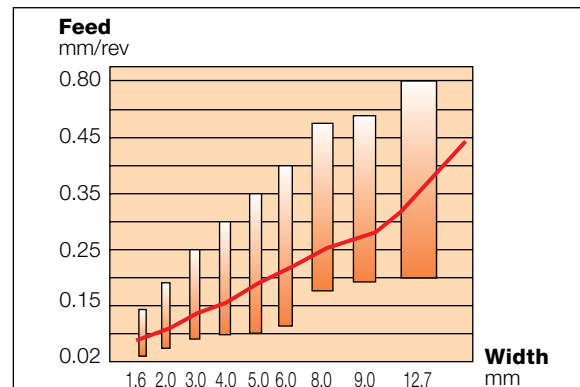

Recommendations are for neutral inserts. For R/L inserts, reduce feed by 20-40%.

MF Type

- Parting and Grooving Insert for Soft and Hard Materials, Medium Feed

$$f \approx \frac{W_{insert}}{21} \text{ [mm/rev]}$$

Alloy Steel	Austenitic Stainless	High Temp. Alloys	Nonferrous Materials	Cast Iron
✓	✓	✓	✗	✓

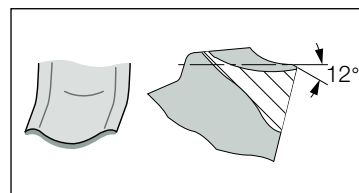

JT-Type

Based on the J-type chipformer with a T-land reinforced frontal cutting edge.

- Provides a solution for the intermediate range between the strong and negative C-type configuration and the positive edged J-type chipformer.
- Can be used on a wide range of materials.
- Same manner as the J-type, but it can be used at higher feeds due to its reinforced edge.

$$f \approx \frac{W \text{ insert}}{24} \text{ [mm/rev]}$$

Alloy Steel	Austenitic Stainless	High Temp. Alloys	Nonferrous Materials	Cast Iron
✓	✓	✓	✗	✓

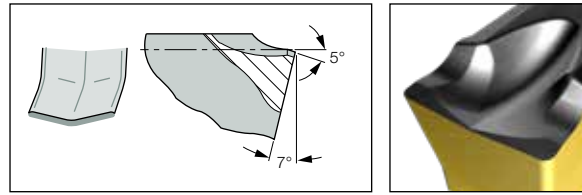

Recommended feed range as a function of insert width

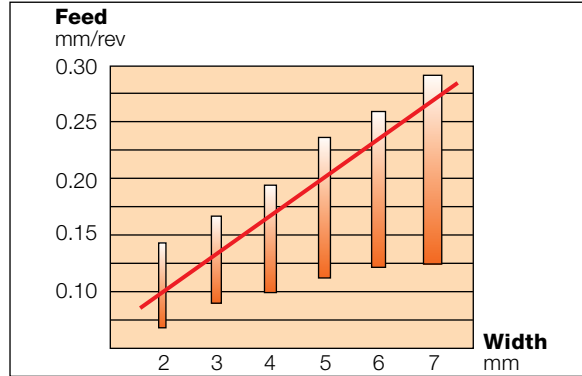

J-Type

- First choice for soft materials, parting tubes, small diameters and thin-walled parts
- Cutting edge with positive rake
- Low-to-medium feed

$$f \approx \frac{W \text{ insert}}{26} \text{ [mm/rev]}$$

Alloy Steel	Austenitic Stainless	High Temp. Alloys	Nonferrous Materials	Cast Iron
✓	✓	✓	✓	✗

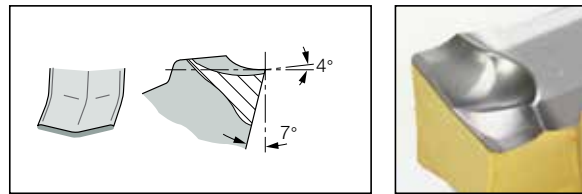

Recommended feed range as a function of insert width

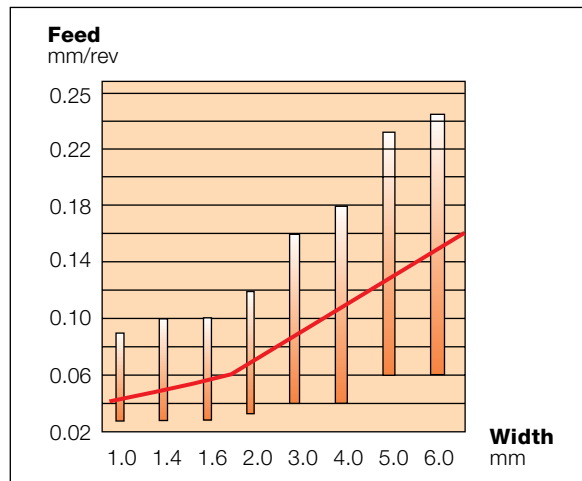

Recommendations are for neutral inserts. For R/L inserts, reduce feed by 20-40%.

Z-Type

- Cutting edge with high positive rake, suitable for parting tubes, thin walled parts and for small diameters
- Suitable for soft materials
- Excellent for cutting bearing steel and stainless steel
- Low-to-medium feeds

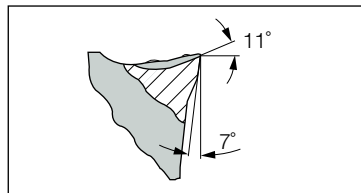

$$f \approx \frac{W \text{ insert}}{28} \text{ [mm/rev]}$$

Alloy Steel	Austenitic Stainless	High Temp. Alloys	Nonferrous Materials	Cast Iron
✓	✓	✓	✓	✗

LF

- Parting and Grooving Insert for Stainless Steel & soft materials
- Miniature Parts
- Low Feeds

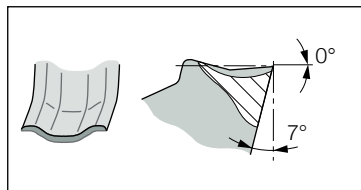

$$f \approx \frac{W \text{ insert}}{31} \text{ [mm/rev]}$$

Alloy Steel	Austenitic Stainless	High Temp. Alloys	Nonferrous Materials	Cast Iron
✓	✓	✓	✗	✗

UA/UT-Type

- A chipformer for use at low feeds
- Recommended for CrNi alloys and low carbon steel, especially in the bearing industry and on similar, ductile materials
- The narrow chipformer design ensures short deformed chips and provides improved performance
- UA and UT are similar chipformers. UT is slightly tighter than the UA chipformer

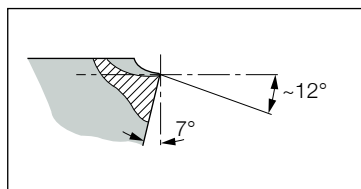

Recommended feed range as a function of insert width

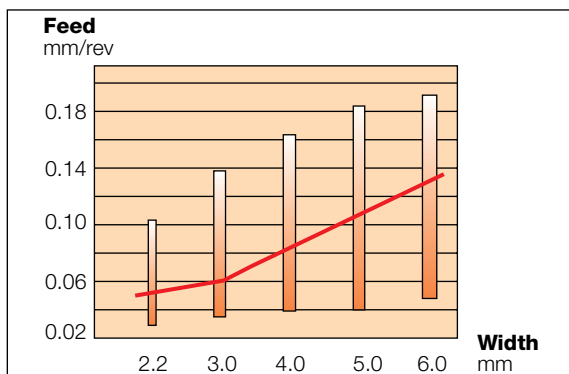

$$f \approx \frac{W \text{ insert}}{40} \text{ [mm/rev]}$$

P-Type

- Very positive rake inclination and sharp cutting edge
- For soft materials, slim parts and general parting
- Low feeds

$$f \approx \frac{W \text{ insert}}{55} \text{ [mm/rev]}$$

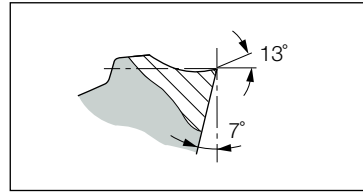

Alloy Steel	Austenitic Stainless	High Temp. Alloys	Nonferrous Materials	Cast Iron
✓	✓	✗	✓	✗

M-Type

- Similar to C-type, but with modified edge (smaller k-land)
- Improved chip control at medium feed

$$f \approx \frac{W \text{ insert}}{22} \text{ [mm/rev]}$$

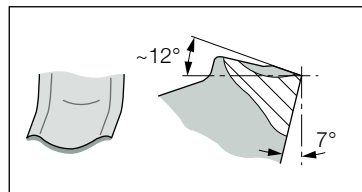

Alloy Steel	Austenitic Stainless	High Temp. Alloys	Nonferrous Materials	Cast Iron
✓	✗	✓	✗	✗

A-Type

- Positive rake, sharp edge
- For parting aluminum
- In grade IC20

$$f \approx \frac{W \text{ insert}}{43} \text{ [mm/rev]}$$

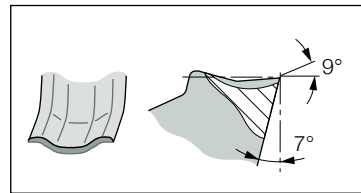

Alloy Steel	Austenitic Stainless	High Temp. Alloys	Nonferrous Materials	Cast Iron
✗	✗	✗	✓	✗

Main Chipformers - Recommended Feed

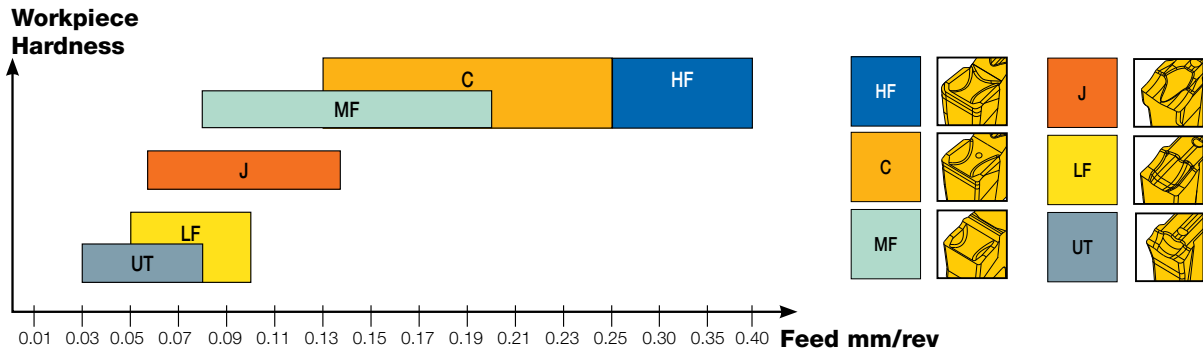

Selection of Chipformers for Various Workpiece Materials

Inserts		Alloy Steel	Austenitic Stainless	High Temp. Alloys	Nonferrous Materials	Cast Iron
High ↑ ↓ Feed ↑ ↓ Low	HF	✓	✗	✗	✗	✓
	C	✓	✗	✓ (IC20 only)	✓ (IC20 only)	✓
	W	✓	✗	✗	✗	✓
	C-jet (Coolant)	✓	✓	✓	✗	✗
	MF	✓	✓ Medium to high feed	✓	✗	✓
	JT	✓	✓	✓	✗	✓
	J	✓	✓	✓	✓	✗
	Z	✓	✓	✓	✓	✗
	LFT	✓	✓	✓	✗	✗
	LF	✓	✓	✓	✗	✗
	UT	✓	✗	✗	✗	✗
	P	✓	✓	✗	✓	✗
A	✗	✗	✗	✓	✗	

✓ First choice

DGFH
Parting and Grooving Blades
with and without Coolant
Channels Carrying DO-GRIP
and HELI-GRIP Inserts

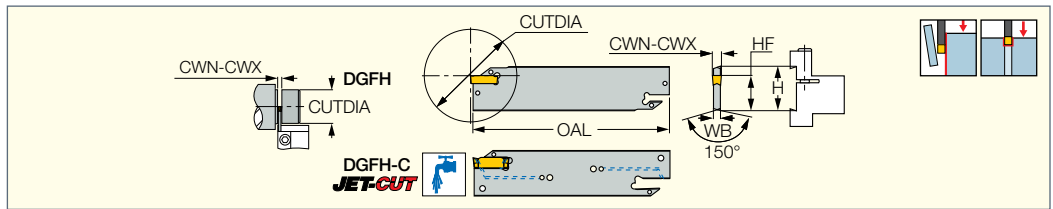

Designation	H	CWN ⁽⁴⁾	CWX ⁽⁵⁾	WB	OAL	HF	CUTDIA	Insert
DGFH 26-1.4	26.0	1.40	1.40	2.50 ⁽⁷⁾	110.00	21.4	26.0	DG. 14..
DGFH 26-2 ⁽¹⁾	26.0	1.90 ⁽⁶⁾	2.50	1.60	110.00	21.4	39.0 ⁽⁸⁾	DG. 1.../DG. 2...
DGFH 26-3 ⁽¹⁾	26.0	3.00 ⁽⁶⁾	3.18	2.40	110.00	21.4	39.0 ⁽⁸⁾	DG. 1.../DG. 3...
DGFH 26C-3 ⁽²⁾	26.0	3.00	3.18	2.40	110.00	21.4	39.0 ⁽⁸⁾	DGNC/DGRC/DGLC 3...
DGFH 26-4	26.0	4.00	4.00	3.20	110.00	21.4	80.0	DG. 4.../GRIP 4...
DGFH 32-1.4	32.0	1.40	1.40	2.50 ⁽⁷⁾	150.00	24.8	26.0	DG. 14
DGFH 32-2 ⁽¹⁾	32.0	1.90 ⁽⁶⁾	2.50	1.80	150.00	24.8	39.0 ⁽⁸⁾	DG. 1.../DG. 2...
DGFH 32-3 ⁽¹⁾	32.0	3.00 ⁽⁶⁾	3.18	2.40	150.00	24.8	39.0 ⁽⁸⁾	DG. 1.../DG. 3...
DGFH 32C-3 ⁽²⁾	32.0	3.00	3.18	2.40	150.00	24.8	39.0 ⁽⁸⁾	DGNC/DGRC/DGLC 3...
DGFH 32-4	32.0	4.00	4.00	3.20	150.00	24.8	100.0	DG. 4.../GRIP 4...
DGFH 32C-4 ⁽³⁾	32.0	4.00	4.00	3.20	150.00	24.8	69.0	DGNC/DGRC/DGLC 4...
DGFH 32-5	32.0	5.00	5.00	4.00	150.00	24.8	120.0	DG. 5.../GRIP 5...
DGFH 32-6	32.0	6.00	6.35	5.20	150.00	24.8	120.0	DG. 6.../GRIP 6...
DGFH 45-3	45.0	3.00 ⁽⁶⁾	3.18	2.40	225.00	38.0	160.0	DG. 1.../DG. 3...
DGFH 45-4	45.0	4.00	4.10	3.20	225.00	38.0	160.0	DG. 4.../GRIP 4...
DGFH 45-5	45.0	4.80	5.00	4.00	225.00	38.0	160.0	DG. 5.../GRIP 5...
DGFH 45-6	45.0	6.00	6.40	5.20	225.00	38.0	160.0	DG. 6.../GRIP 6...

• DG..1.0 insert can be mounted into pocket sizes 2 and 3, in which case the pocket width has to be modified • For user guide, see pages 484-492

⁽¹⁾ For CUTDIA 50 mm, use single-ended insert (should be modified by the user)

⁽²⁾ Blades with frontal coolant holes (JETCUT) • For CUTDIA 50 mm, use single-ended insert (should be modified by the user)

⁽³⁾ These blades are suitable for turning, using GRIP 4 inserts • Blades with frontal coolant holes (JETCUT)

⁽⁴⁾ Minimum cutting width

⁽⁵⁾ Maximum cutting width

⁽⁶⁾ For DG. 1... insert, modify holder

⁽⁷⁾ Thickness at the D.O.C. area is 1.0 mm

⁽⁸⁾ Maximum diameter with double-sided inserts.

For inserts, see pages: DGN-LF/LFT (441) • DGN-MF (442) • DGN/DGNC/DGNM-C (438) • DGR/L-C DGRC/LC-C (439) • DGN/DGNM-J/JS/JT (440) • DGR/L-J/JS (441) • DGN-P (444) • DGN-UT/UA (443) • DGN-W (439) • DGN-WP (444) • DGN-Z (442) • DGR-P (444) • DGR-WP (445) • DGR-Z/ZS (443) • GRIP (254) • GRIP (full radius) (255)

For holders, see pages: C#-TBK-R/L (591) • HSK A-WH-TBK-R/L (598) • SGTBF (687) • SGTBK (587) • SGTBR/L (587) • SGTBU/SGTBN (586) • UBHCR/L (587)

Spare Parts

Designation						
DGFH 26-1.4	EDG 23B*					
DGFH 26-2	EDG 23A*					
DGFH 26-3	EDG 23A*					
DGFH 26C-3	EDG 23A*	SGC 340	SGCU 341*	CGF 343*	CF 343*	CGM 343*
DGFH 26-4	EDG 23A*					
DGFH 32-1.4	EDG 23B*					
DGFH 32-2	EDG 33A*					
DGFH 32-3	EDG 33A*					
DGFH 32C-3	EDG 33A*	SGC 340	SGCU 341*	CGF 343*	CF 343*	CGM 343*
DGFH 32-4	EDG 33A*					
DGFH 32C-4	EDG 33A*	SGC 340	SGCU 341*	CGF 343*	CF 343*	CGM 343*
DGFH 32-5	EDG 33A*					
DGFH 32-6	EDG 33A*					
DGFH 45-3	EDG 33A*					
DGFH 45-4	EDG 33A*					
DGFH 45-5	EDG 33A*					
DGFH 45-6	EDG 33A*					

* Optional, should be ordered separately

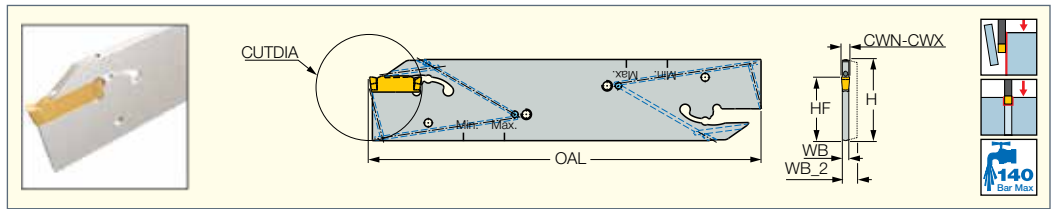

DO-GRIP
 TWISTED 2-SIDED **JETCUT**
DGFH-JHP

 Parting and Grooving Blades
 with Channels for Low and
 High Pressure Coolant
 Carrying DO-GRIP Inserts

Designation	CWN ⁽²⁾	CWX ⁽³⁾	WB	WB_2	OAL	H	HF	CUTDIA	Insert	⊕	✎
DGFH 32-2-JHP ⁽¹⁾	1.90 ⁽⁴⁾	2.50	1.80	2.5	150.00	32.0	24.8	39.0	DG. 1.../DG. 2...	SGC 340	EDG 33A-JHP*
DGFH 32-3-JHP	3.00 ⁽⁴⁾	3.18	2.50	-	152.00	32.0	24.8	90.0	DG. 1.../DG. 3...	SGC 340	EDG 33A-JHP*
DGFH 32-4-JHP	4.00	4.00	3.20	-	152.00	32.0	24.9	90.0	DG. 4.../GRIP 4...	SGC 340	EDG 33A-JHP*
DGFH 32-5-JHP	5.00	5.00	4.00	-	152.00	32.0	24.9	90.0	DG. 5.../GRIP 5...	SGC 340	EDG 33A-JHP*
DGFH 32-6-JHP ⁽¹⁾	6.00	6.35	5.20	-	160.00	32.0	24.9	90.0	DG. 6.../GRIP 6...	SGC 340	EDG 33A-JHP*

• For user guide and accessories, see pages 484-492

⁽¹⁾ Only an upper channel

⁽²⁾ Minimum cutting width

⁽³⁾ Maximum cutting width

⁽⁴⁾ For DG. 1... insert, modify holder

* Optional, should be ordered separately

For inserts, see pages: DGN-LF/LFT (441) • DGN-MF (442) • DGN-P (444) • DGN-UT/UA (443) • DGN-W (439) • DGN-WP (444) • DGN-Z (442) • DGN/DGNC/DGNM-C (438) • DGN/DGNM-J/JS/JT (440) • DGR-P (444) • DGR-WP (445) • DGR-Z/ZS (443) • DGR/L-C DGRC/LC-C (439) • DGR/L-J/JS (441) • GRIP (254) • GRIP (full radius) (255)

For holders, see pages: TGTBU-JHP (454)

DO-GRIP
 TWISTED 2-SIDED

DGFHR/L

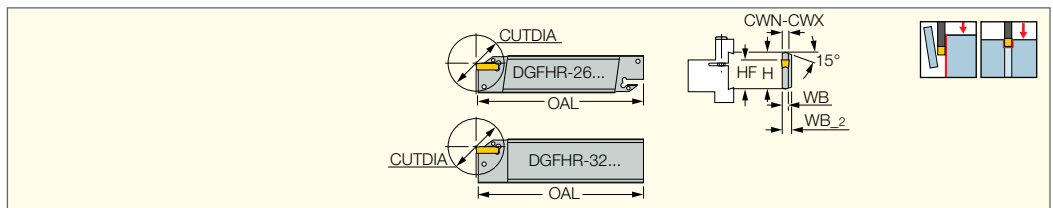
 Parting and Grooving Reinforced
 Blades for DO-GRIP Inserts

Designation	H	CWN ⁽¹⁾	CWX ⁽²⁾	WB_2	WB	OAL	HF	CUTDIA ⁽³⁾	Machines	Insert	✎
DGFHR 26T16-2	26.0	1.90	2.50	8.0	1.70	110.00	21.4	42.0	TNS-30	DG. 1.../DG. 2..	EDG 23A*
DGFHR/L 26T23-2	26.0	1.90	2.50	8.0	1.60	110.00	21.4	42.0	TNS-30/112	DG. 1.../DG. 2..	EDG 23A*
DGFHR/L 26T16-3	26.0	3.00	3.18	8.0	2.40	110.00	21.4	30.0	TNS-30	DG. 1.../DG. 3..	EDG 23A*
DGFHR/L 26T23-3	26.0	3.00	3.18	8.0	2.40	110.00	21.4	42.0	TNS-30/42	DG. 1.../DG. 3..	EDG 23A*
DGFHR/L 32T22-2	32.0	1.90	2.50	8.0	1.60	110.00	24.8	42.0	TNS-42	DG. 1.../DG. 2..	EDG 33A*
DGFHR/L 32T22-4	32.0	4.00	4.00	8.0	3.40	110.00	24.8	42.0	TNS-42	DG. 4.../GRIP 4..	EDG 33A*
DGFHR/L 32T33-3	32.0	3.00	3.18	8.0	2.40	110.00	24.8	60.0	TNS-42/60/65	DG. 1.../DG. 3..	EDG 33A*
DGFHR/L 32T33-4	32.0	4.00	4.00	8.0	3.40	110.00	24.8	60.0	TNS-42/60/65	DG. 4.../GRIP 4..	EDG 33A*
DGFHR/L 32T41-4	32.0	4.00	4.00	10.0	3.40	110.00	24.8	80.0	TNS-65/80/480	DG. 4.../GRIP 4..	EDG 33A*

 • Insert limit is T_{max}=18 mm. If deeper penetration is required, the insert should be modified into single-ended by the user. • DG..1.0 insert can be mounted into pocket sizes 2 and 3, in which case the pocket width has to be modified - see page 436 • For user guide, see pages 484-492

⁽¹⁾ Minimum cutting width • For DG: 1.0 insert - modify holder

⁽²⁾ Maximum cutting width

⁽³⁾ The specified limit refers to the tool

* Optional, should be ordered separately

For inserts, see pages: DGN-LF/LFT (441) • DGN-P (444) • DGN-UT/UA (443) • DGN-WP (444) • DGN-Z (442) • DGN/DGNC/DGNM-C (438) • DGN/DGNM-J/JS/JT (440) • DGR-P (444) • DGR-WP (445) • DGR-Z/ZS (443) • DGR/L-C DGRC/LC-C (439) • DGR/L-J/JS (441)

For holders, see pages: C#-TBK-R/L (591) • HSK A-WH-TBK-R/L (598) • SGTBF (587) • SGTBR/L (587) • SGTBU/SGTBN (586) • UBHCR/L (587)

DGFHR/L-BC-JHP
Parting and Grooving
Reinforced Blades with
Channels for High Pressure
Coolant for DO-GRIP Inserts

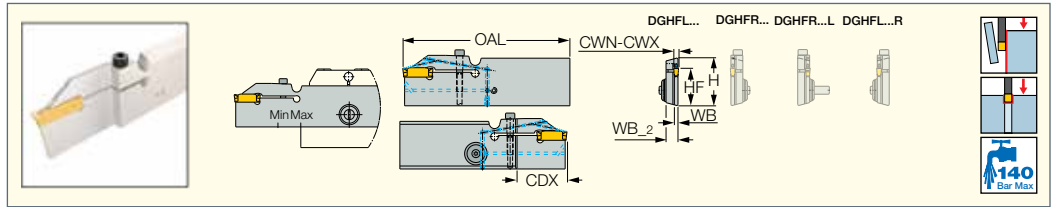

Designation	CWN ⁽¹⁾	CWX ⁽²⁾	WB_2	WB	OAL	H	HF	CDX ⁽³⁾	Insert			
DGFHR/L 32BC-3T33-JHP	3.00	3.18	7.9	2.40	111.00	32.0	24.8	33.00	DG. 3..	SR M4-21532	HW 3.0	SGC 340
DGFHL 32BC-3T33R-JHP	3.00	3.18	7.9	2.40	111.00	32.0	24.8	33.00	DG. 3..	SR M4-21532	HW 3.0	SGC 340
DGFHR 32BC-3T33L-JHP	3.00	3.18	7.9	2.40	111.00	32.0	24.8	33.00	DG. 3..	SR M4-21532	HW 3.0	SGC 340

- For user guide and accessories, see pages 484-492
- (1) **Minimum cutting width** • For DG: 1.0 insert - modify holder
- (2) Maximum cutting width
- (3) The specified limit refers to the tool

For inserts, see pages: DGN-LF/LFT (441) • DGN-MF (442) • DGN-P (444) • DGN-UT/UA (443) • DGN-Z (442) • DGN/DGNC/DGNM-C (438) • DGN/DGNM-J/JS/JT (440) • DGR-Z/ZS (443) • DGR/L-C DGRC/LC-C (439) • DGR/L-J/JS (441)
For holders, see pages: TGTBU-JHP (454)

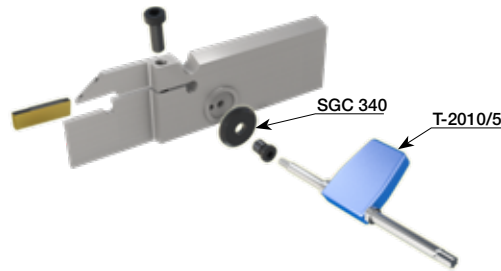

DGFS
Blades for Multi-Spindle
Machines, Replacement for
HSS and Brazed Tools

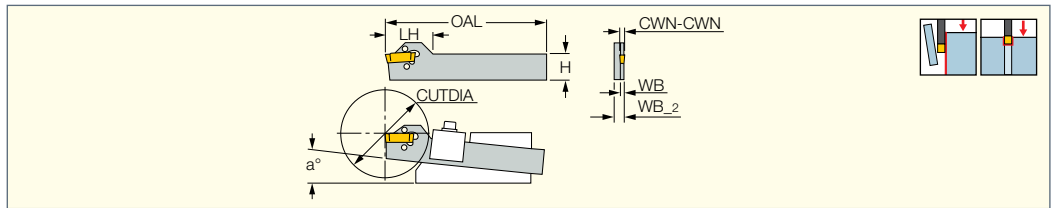

Designation	H	CWN ⁽⁷⁾	CWX ⁽⁸⁾	CUTDIA	WB	WB_2	OAL	LH	a°	
DGFS 0-12-2 (1)	12.7	1.90	2.50	32.0	1.60	3.2	110.00	32.0	0	EDG 33B*
DGFS 0-17-2 (2)	17.4	1.90	2.50	35.0	1.60	3.2	110.00	32.0	0	EDG 33B*
DGFS 0-17-3 (2)	17.4	3.00	3.18	60.0	2.40	3.2	110.00	32.0	0	EDG 33B*
DGFS 5-17-2 (3)	17.4	1.90	2.50	35.0	1.60	3.2	110.00	32.0	5	EDG 33B*
DGFS 5-17-3 (3)	17.4	3.00	3.18	60.0	2.40	3.2	110.00	32.0	5	EDG 33B*
DGFS 5-17-4 (3)	17.4	4.00	4.00	60.0	3.20	3.2	110.00	32.0	5	EDG 33B*
DGFS 5-22-2 (4)	22.2	1.90	2.50	50.0	1.60	3.2	150.00	32.0	5	EDG 33B*
DGFS 5-22-3 (5)	22.2	3.00	3.18	75.0	2.40	3.2	150.00	32.0	5	EDG 33B*
DGFS 5-22-4 (5)	22.2	4.00	4.00	80.0	3.20	3.2	150.00	32.0	5	EDG 33B*
DGFS 5-24-3	23.8	3.00	3.18	80.0	2.40	3.2	150.00	32.0	5	EDG 33B*
DGFS 5-28-2 (6)	28.5	1.90	2.50	65.0	1.60	3.2	150.00	32.0	5	EDG 33B*
DGFS 5-28-4 (6)	28.5	4.00	4.00	100.0	3.20	3.2	150.00	32.0	5	EDG 33B*

- DG..1.0 insert can be mounted into pocket sizes 2 and 3, in which case the pocket width has to be modified -see page 436 • For user guide, see pages 484-492
- (1) Toolholder assembly X18-1,46,47-WT,160-CL,354-CL,701-ACL,702,702-CL,703,703-CL,704,704-CL,6921,6925
- (2) Toolholder assembly E-7,47,102-CL,103-CL,161-A-CL,162-A-CL
- (3) Toolholder assembly 226,226-CL,275,275-CL,276-CL,361-CL,431,630,707-A,707-A-CL
- (4) Toolholder assembly 100-CL,274,277,277-CL,274-CL,370,383-CL, 6722,6754,6755,6854,6855,6922,51,51-CL,353-CL,167,370-CL
- (5) Toolholder assembly 100-CL,274,277,277-CL,274-CL,370,383-CL, 6722,6754,6755,6854,6855,51,51-CL,353-CL,167,370-CL
- (6) Toolholder assembly 278,278-CL,279,279-CL,280,280-CL,281,281-CL,375-CL,359-CL,372-CL,A6120,52,52-CL
- (7) **Minimum cutting width** • For DG: 1.0 insert - modify holder
- (8) Maximum cutting width

* Optional, should be ordered separately

For inserts, see pages: DGN-LF/LFT (441) • DGN/DGNC/DGNM-C (438) • DGR/L-C DGRC/LC-C (439) • DGN/DGNM-J/JS/JT (440) • DGR/L-J/JS (441) • DGN-P (444) • DGN-UT/UA (443) • DGN-WP (444) • DGN-Z (442) • DGR-P (444) • DGR-WP (445) • DGR-Z/ZS (443) • GRIP (254) • GRIP (full radius) (255)

DOGRIP
 TWISTED 2-SIDED

DGFHR/L-B-D..(R/L)

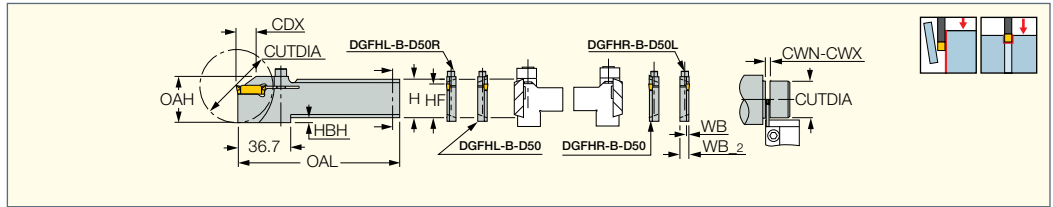
 Reinforced Type Blades
 with Screw Clamping

Designation	H ⁽⁴⁾	CWN ⁽⁵⁾	CWX ⁽⁶⁾	WB	WB_2	OAL	OAH	HF	HBH	CDX ⁽⁷⁾	CUTDIA ⁽⁸⁾	Insert		
DGFHR/L 26B-2D50 ⁽¹⁾	26.0	1.90	2.50	1.60	8.0	110.00	33.7	21.4	3.6	18.00	42.0	DG. 1.../DG. 2..	SR M4X20 DIN912	HW 3.0
DGFHL 26B-2D50R ⁽²⁾	26.0	1.90	2.50	1.60	8.0	110.00	31.5	21.4	3.7	18.00	50.0	DG. 1.../DG. 2..	SR M4X20 DIN912	HW 3.0
DGFHR 26B-2D50L ⁽²⁾	26.0	1.90	2.50	1.60	8.0	110.00	31.5	21.4	3.7	18.00	50.0	DG. 1.../DG. 2..	SR M4X20 DIN912	HW 3.0
DGFHR/L 26B-3D50 ⁽¹⁾	26.0	3.00	3.18	2.40	8.0	110.00	31.5	21.4	3.7	18.00	30.0	DG. 1.../DG. 3..	SR M4X20 DIN912	HW 3.0
DGFHL 26B-3D50R ⁽²⁾	26.0	3.00	3.18	2.40	8.0	110.00	31.5	21.4	3.7	18.00	50.0	DG. 1.../DG. 3..	SR M4X20 DIN912	HW 3.0
DGFHR 26B-3D50L ⁽²⁾	26.0	3.00	3.18	2.40	8.0	110.00	31.5	21.4	3.7	18.00	50.0	DG. 1.../DG. 3..	SR M4X20 DIN912	HW 3.0
DGFHR/L 32B-2D50 ⁽³⁾	32.0	1.90	2.50	1.60	8.0	120.00	31.5	24.8	-	18.00	42.0	DG. 1.../DG. 2..	SR M4X20 DIN912	HW 3.0
DGFHL 32B-2D50R ⁽²⁾	32.0	1.90	2.50	1.60	8.0	120.00	31.5	24.8	-	18.00	50.0	DG. 1.../DG. 2..	SR M4X20 DIN912	HW 3.0
DGFHR 32B-2D50L ⁽²⁾	32.0	1.90	2.50	1.60	8.0	120.00	31.5	24.8	-	18.00	50.0	DG. 1.../DG. 2..	SR M4X20 DIN912	HW 3.0
DGFHR/L 32B-3D50 ⁽³⁾	32.0	3.00	3.18	2.40	8.0	120.00	31.5	24.8	-	18.00	42.0	DG. 1.../DG. 3..	SR M4X20 DIN912	HW 3.0
DGFHL 32B-3D50R ⁽²⁾	32.0	3.00	3.18	2.40	8.0	120.00	31.5	24.8	-	18.00	50.0	DG. 1.../DG. 3..	SR M4X20 DIN912	HW 3.0
DGFHR 32B-3D50L ⁽²⁾	32.0	3.00	3.18	2.40	8.0	120.00	31.5	24.8	-	18.00	50.0	DG. 1.../DG. 3..	SR M4X20 DIN912	HW 3.0

• Insert limit is T_{max}=18 mm. If deeper penetration is required, the insert should be modified into single-ended by the user • DG..1.0 insert can be mounted into pocket sizes 2 and 3, in which case the pocket width has to be modified - see page 436 • For user guide, see pages 484-492

⁽¹⁾ For Traub machines, model TNC 30, TNM 28, TNS 26/30/42/112, TNA 300, TNK 260

⁽²⁾ For Tornos Bechler, Emco 2000/20, 2000/26 machines

⁽³⁾ For Traub machines, model TNC 42/65, TNM 42/65, TNS 42/60/65, TNA 300/400

⁽⁴⁾ Mounted on all ISCAR standard blocks

⁽⁵⁾ Minimum cutting width • For DG: 1.0 insert - modify holder

⁽⁶⁾ Maximum cutting width

⁽⁷⁾ Cutting depth maximum

⁽⁸⁾ The specified limit refers to the tool

For inserts, see pages: DGN-LF/LFT (441) • DGN-P (444) • DGN-UT/UA (443) • DGN-WP (444) • DGN-Z (442) • DGN/DGNC/DGNM-C (438) • DGN/DGNM-J/JS/JT (440) • DGR-P (444) • DGR-WP (445) • DGR-Z/ZS (443) • DGR/L-C DGRC/LC-C (439) • DGR/L-J/JS (441)

For holders, see pages: C#-TBK-R/L (591) • HSK A-WH-TBK-R/L (598) • SGTBF (587) • SGTBR/L (587) • SGTBU/SGTBN (586) • UBHCR/L (587)

DOGRIP
 TWISTED 2-SIDED

DGFHL-26B-TR-D

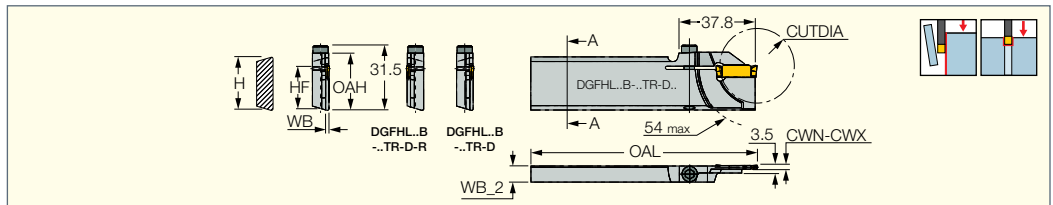
 Reinforced Type Blades with
 Screw Clamping for Traub
 and Index Machines

Designation	H ⁽²⁾	CWN ⁽³⁾	CWX ⁽⁴⁾	WB	WB_2	OAL	OAH	HF	CUTDIA ⁽⁵⁾	Insert		
DGFHL 26B-1.5TR-D20 ⁽¹⁾	26.0	1.00	1.50	1.20	7.9	110.00	27.9	21.4	20.0	DG. 1.../DG. 15..	SR M5X20-01172	HW 3.0
DGFHL 26B-2TR-D36	26.0	1.90 ⁽⁶⁾	2.50	1.60	7.9	110.00	27.9	21.4	36.0	DG. 1.../DG. 2..	SR M5X20-01172	HW 3.0
DGFHL 26B-2TR-D36R	26.0	1.90 ⁽⁶⁾	2.50	1.60	7.9	110.00	27.9	21.4	36.0	DG. 1.../DG. 2..	SR M4X20 DIN912	HW 3.0
DGFHL 26B-3TR-D36	26.0	3.00 ⁽⁶⁾	3.18	2.40	7.9	110.00	27.9	21.4	36.0	DG. 1.../DG. 3..	SR M5X20-01172	HW 3.0
DGFHL 26B-3TR-D36R	26.0	3.00 ⁽⁶⁾	3.18	2.40	7.9	110.00	27.9	21.4	36.0	DG. 1.../DG. 3..	SR M5X20-01172	HW 3.0

• Insert limit is T_{max}=18 mm. If deeper penetration is required, the insert should be modified into single-ended by the user • DG..1.0 insert can be mounted into pocket sizes 2 and 3, in which case the pocket width has to be modified - see page 436 • For user guide, see pages 484-492

⁽¹⁾ Do not use DG.. 1.4 on this tool!

⁽²⁾ Mounted on all ISCAR standard blocks

⁽³⁾ Minimum cutting width

⁽⁴⁾ Maximum cutting width

⁽⁵⁾ The specified limit refers to the tool

⁽⁶⁾ For DG: 1.0 insert - modify holder

For inserts, see pages: DGN-LF/LFT (441) • DGN-P (444) • DGN-UT/UA (443) • DGN-WP (444) • DGN-Z (442) • DGN/DGNC/DGNM-C (438) • DGN/DGNM-J/JS/JT (440) • DGR-Z/ZS (443) • DGR/L-C DGRC/LC-C (439) • DGR/L-J/JS (441)

DGTR/L-B-D-SH

Parting and Grooving Short
Head Tools for CNC and
Swiss Automatics

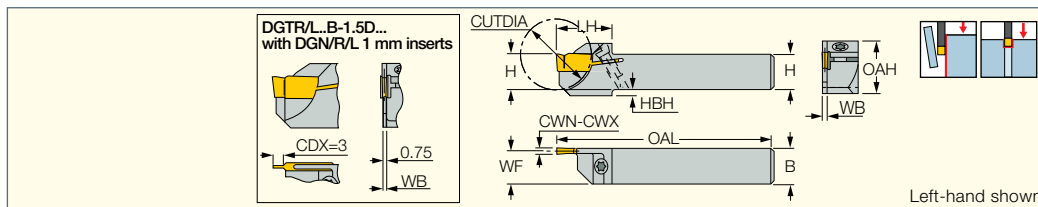

Designation	CWN ⁽²⁾	CWX ⁽³⁾	H	B	WB	WF	LH	CUTDIA	OAH	HBH	OAL	Insert		
DGTR/L 8B-1.4SH	1.40	1.40	8.0	8.0	1.00	7.50	18.0	10.0	15.4	2.0	125.00	DG. 14..	SR 16-236 P(a)	T-15/5
DGTR/L 10B-1.4D20SH	1.40	1.40	10.0	10.0	1.00	9.50	18.0	20.0	13.7	-	120.00	DG. 14..	SR 16-236 P(a)	T-15/5
DGTR/L 10B-1.5D20SH (1)	1.00	1.50	10.0	10.0	1.00	9.50	19.0	20.0	15.7	2.0	120.00	DG. 1.../DG. 15..	SR 16-236 P(a)	T-15/5
DGTR/L 10B-2D20SH	1.90	2.50	10.0	10.0	1.60	9.20	19.0	20.0	15.7	2.0	120.00	DG. 1.../DG. 2..	SR 16-236 P(a)	T-15/5
DGTR/L 12B-1.4D24SH	1.40	1.40	12.0	12.0	1.00	11.50	19.0	24.0	15.7	-	120.00	DG. 14..	SR 16-236 P(a)	T-15/5
DGTR/L 12B-1.5D24SH (1)	1.00	1.50	12.0	12.0	1.00	11.40	19.0	24.0	15.7	-	120.00	DG. 1.../DG. 15..	SR 16-236 P(a)	T-15/5
DGTR/L 12B-2D24SH	1.90	2.50	12.0	12.0	1.60	11.20	19.0	24.0	15.7	-	120.00	DG. 1.../DG. 2..	SR 16-236 P(a)	T-15/5
DGTR/L 12B-2D24SH-L85	1.90	2.50	12.0	12.0	1.60	11.20	19.0	24.0	15.7	-	85.00	DG. 1.../DG. 2..	SR 16-236 P(a)	T-15/5
DGTR/L 12B-3D24SH	3.00	3.18	12.0	12.0	2.40	10.80	19.0	24.0	15.7	-	120.00	DG. 3.../DG. 10..	SR 16-236 P(a)	T-15/5
DGTR/L 16B-1.5D25SH (1)	1.00	1.50	16.0	16.0	1.20	15.40	19.5	25.4	19.7	-	120.00	DG. 1.../DG. 15..	SR 16-236 P(a)	T-15/5
DGTR/L 16B-2D25SH	1.90	2.50	16.0	16.0	1.60	15.20	19.5	25.4	19.7	-	120.00	DG. 1.../DG. 2..	SR 16-236 P(a)	T-15/5
DGTR/L 16B-3D25SH	3.00	3.18	16.0	16.0	2.40	14.80	19.5	25.4	19.7	-	120.00	DG. 1.../DG. 3..	SR 16-236 P(a)	T-15/5
DGTR/L 20B-1.5D25SH (1)	1.00	1.50	20.0	20.0	1.20	19.40	19.5	25.4	23.7	-	120.00	DG. 1.../DG. 15..	SR 16-236 P(a)	T-15/5
DGTR/L 20B-3D25SH	3.00	3.18	20.0	20.0	2.40	18.80	19.5	25.4	23.7	-	120.00	DG. 1.../DG. 3..	SR 16-236 P(a)	T-15/5

• DGN/R/L 1 mm inserts can also be mounted into pocket sizes 2 and 3. For insert depth capacity table and modification instructions for the 2 and 3 holder pockets, see page 436 • For user guide, see pages 484-492

(1) Do not use DG.. 1.4 on this tool!

(2) Minimum cutting width

(3) Maximum cutting width

(a) Recommended tightening torque for this item: 3 N*M (26.5 lb*in)

For inserts, see pages: DGN-LF/LFT (441) • DGN-P (444) • DGN-UT/UA (443) • DGN-WP (444) • DGN-Z (442) • DGN/DGNC/DGNM-C (438) • DGN/DGNM-J/JS/JT (440) • DGR-P (444) • DGR-WP (445) • DGR-Z/ZS (443) • DGR/L-C DGRC/LC-C (439) • DGR/L-J/JS (441)

Depth Capacity DGTR/L-B-D

Depth of Cut Function of
Workpiece Diameter
(DGN/R/L-100... excluded)

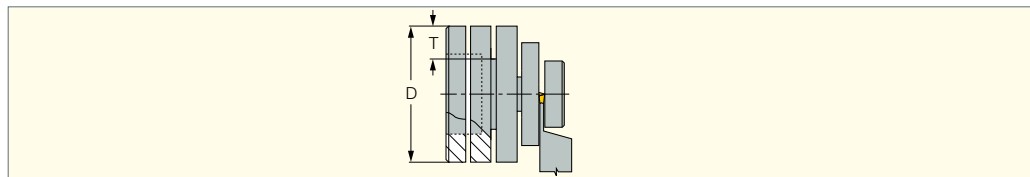

Designation	øD _{max}																
DGTR/L 10B-1.4D20	-	-	-	-	-	-	-	-	-	-	20	23	26	32	45	76	NL
DGTR/L 12B-1.4D30	-	-	-	-	-	30	32	35	38	43	50	62	83	125	300	NL	NL
DGTR/L 16B-1.4D30	-	-	-	-	-	30	32	35	38	43	50	62	83	125	300	NL	NL
DGTR/L 20B-1.4D30	-	-	-	-	-	30	32	35	38	43	50	62	83	125	300	NL	NL
DGTR/L 10B-2D30	-	-	-	-	-	30	32	35	38	43	50	62	83	125	300	NL	NL
DGTR/L 12B-2D30	-	-	-	-	-	30	32	35	38	43	50	62	83	125	300	NL	NL
DGTR/L 16B-2D32	-	-	-	-	32	35	37	41	47	55	69	93	150	400	NL	NL	NL
DGTR/L 20B-2D35	-	-	-	75	90	113	155	250	650	NL	NL	NL	NL	NL	NL	NL	NL
DGTR/L 25B-2D35	-	-	-	75	90	113	155	250	650	NL	NL	NL	NL	NL	NL	NL	NL
DGTR/L 12B-3D30	-	-	-	-	-	30	32	35	38	43	50	62	83	125	300	NL	NL
DGTR/L 16B-3D35	-	-	-	35	39	42	46	51	59	71	91	130	230	1200	NL	NL	NL
DGTR/L 20B-3D40	56	62	71	83	102	134	200	400	NL	NL	NL	NL	NL	NL	NL	NL	NL
DGTR/L 25B-3D40	56	62	71	83	102	134	200	400	NL	NL	NL	NL	NL	NL	NL	NL	NL

Depth T → 20 19 18 17 16 15 14 13 12 11 10 9 8 7 6 5 4

NL - No Limit
Example:
For 9 mm depth of groove on a 75 mm workpiece diameter, six tools may be used.



DGTR/L-B-D-JHP-SL
Parting and Grooving Side
Lock Type Tools with High
Pressure Coolant for CNC
and Swiss Automatics

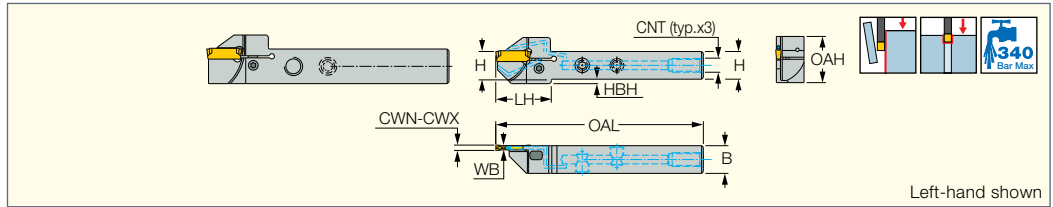

Designation	CWN ⁽¹⁾	CWX ⁽²⁾	H	B	WB	LH	CUTDIA ⁽³⁾	OAH	HBH	OAL	Insert	CNT
DGTR/L 12B-2D24-JHP-SL	1.90	2.50	12.0	12.0	1.70	29.4	24.0	25.7	6.5	100.00	DG. 2...	5/16"-24 UNF
DGTR/L 16B-2D35-JHP-SL	1.90	2.50	16.0	16.0	1.70	32.0	35.0	26.7	2.6	120.00	DG. 2...	5/16"-24 UNF
DGTR/L 20B-2D35-JHP-SL	1.90	2.50	20.0	20.0	1.70	32.0	35.0	28.1	-	140.00	DG. 2...	1/8"-28 BSPP
DGTR/L 12B-3D24-JHP-SL	3.00	3.18	12.0	12.0	2.40	29.4	24.0	25.7	6.5	100.00	DG. 3..	5/16"-24 UNF
DGTR/L 16B-3D35-JHP-SL	3.00	3.18	16.0	16.0	2.40	32.0	35.0	26.7	2.6	120.00	DG. 3..	5/16"-24 UNF
DGTR/L 20B-3D40-JHP-SL	3.00	3.18	20.0	20.0	2.40	35.6	40.0	28.1	-	140.00	DG. 3..	1/8"-28 BSPP
DGTR/L 25B-2D35-JHP-SL	1.90	2.50	25.0	25.0	1.70	32.1	35.0	33.1	-	140.00	DG. 2..	1/8"-28 BSPP
DGTR/L 25B-3D40-JHP-SL	3.00	3.18	25.0	25.0	2.40	35.6	40.0	33.1	-	140.00	DG. 3..	1/8"-28 BSPP
DGTR/L 25B-4D40-JHP-SL	4.00	4.76	25.0	25.0	3.40	34.6	40.0	33.0	-	140.00	DG..4..	1/8"-28 BSPP

• For insert depth capacity table and modification instructions for the holder pockets, see page 436 • For user guide, see pages 484-492

- ⁽¹⁾ Minimum cutting width
- ⁽²⁾ Maximum cutting width
- ⁽³⁾ Maximum cutting diameter

For inserts, see pages: DGN-MF (442) • DGN-P (444) • DGN-UT/UA (443) • DGN-WP (444) • DGN-Z (442) • DGN/DGNC/DGNM-C (438) • DGN/DGNM-J/JS/JT (440) • DGR-P (444) • DGR-Z/ZS (443) • DGR/L-C DGRC/LC-C (439)

Depth Capacity
DGTR/L-B-D-JHP-SL
Depth of Cut Function of
Workpiece Diameter
(DGN/R/L-100... excluded)

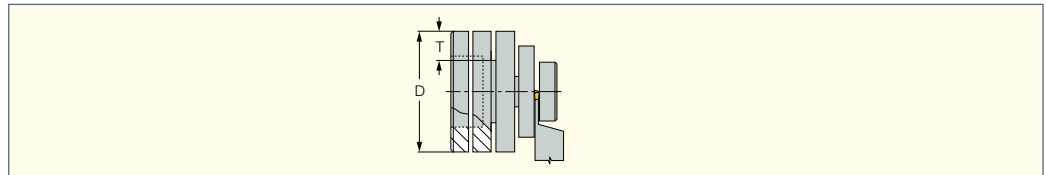

Designation	øD _{max}															
DGTR/L 12B-2D24-JHP-SL	-	-	-	-	-	-	-	24	26	27	28	30	32	36	42	52
DGTR/L 16B-2D35-JHP-SL	-	-	-	-	-	-	-	24	26	27	28	30	32	36	42	52
DGTR/L 20B-2D35-JHP-SL	-	-	-	35	39	42	46	51	59	71	91	130	230	1200	NL	NL
DGTR/L 25B-2D35-JHP-SL	-	-	-	65	70	75	80	90	100	120	140	180	250	410	1200	NL
DGTR/L 12B-3D24-JHP-SL	-	-	-	35	39	42	46	51	59	71	91	130	230	1200	NL	NL
DGTR/L 16B-3D35-JHP-SL	-	-	-	75	90	113	155	250	650	NL	NL	NL	NL	NL	NL	NL
DGTR/L 20B-3D40-JHP-SL	56	62	71	83	102	134	200	400	NL	NL	NL	NL	NL	NL	NL	NL
DGTR/L 25B-3D40-JHP-SL	50	55	60	67	75	85	100	115	140	200	350	NL	NL	NL	NL	NL

Depth T	20	19	18	17	16	15	14	13	12	11	10	9	8	7	6	5	4
---------	----	----	----	----	----	----	----	----	----	----	----	---	---	---	---	---	---

NL - No Limit

Example:
For a 9 mm depth of groove on a 75 mm workpiece diameter, six tools may be used.

Flow Rate vs. Pressure

Designation	70 Bar Flow Rate (liters/min)	100 Bar Flow Rate (liters/min)	140 Bar Flow Rate (liters/min)
DGTR/L ...2-JHP-SL	3-4	4-5	5-6
DGTR/L ...3-JHP-SL	5-6	6-7	7-8

Spare Parts

Designation						
DGTR/L 12B-2D24-JHP-SL	PIN-32121	SR M5-24145	SR 5/16UNF TL360	BLD HW2.5	HW 5/32"	SW6-SD
DGTR/L 16B-2D35-JHP-SL	PIN-32121	SR M5-24145	SR 5/16UNF TL360	BLD HW2.5	HW 5/32"	SW6-SD
DGTR/L 20B-2D35-JHP-SL	PIN-32121	SR M5-24145	PLUG G1/8-6.5 TL360	BLD HW2.5	HW 5.0	SW6-SD
DGTR/L 12B-3D24-JHP-SL	PIN-32121	SR M5-24145	SR 5/16UNF TL360	BLD HW2.5	HW 5/32"	SW6-SD
DGTR/L 16B-3D35-JHP-SL	PIN-32121	SR M5-24145	SR 5/16UNF TL360	BLD HW2.5	HW 5/32"	SW6-SD
DGTR/L 20B-3D40-JHP-SL	PIN-32121	SR M5-24145	PLUG G1/8-6.5 TL360	BLD HW2.5	HW 5.0	SW6-SD
DGTR/L 25B-2D35-JHP-SL	PIN-32121	SR M5-24145	PLUG G1/8-6.5 TL360	BLD HW2.5	HW 5.0	SW6-SD
DGTR/L 25B-3D40-JHP-SL	PIN-32121	SR M5-24145	PLUG G1/8-6.5 TL360	BLD HW2.5	HW 5.0	SW6-SD

DGTR/L-B-D-JHP-SL-MC
Parting and Grooving Side Lock
Type Tools with Bottom Inlets
for High Pressure Coolant

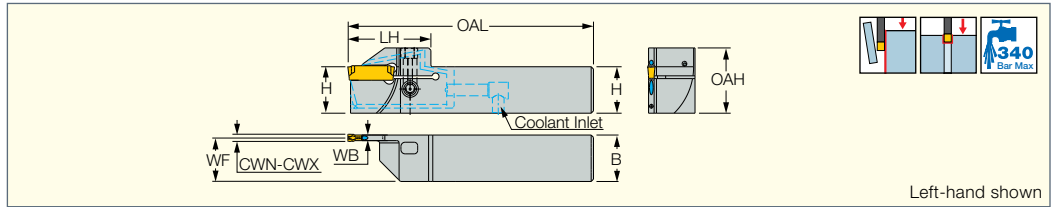





Designation	CWN ⁽¹⁾	CWX ⁽²⁾	H	B	WB	WF	LH	CUTDIA ⁽³⁾	OAH	OAL	Insert
DGTR/L 20B-2D35-JHP-SL-MC	1.90	2.50	20.0	20.0	1.70	19.15	32.1	35.0	28.1	102.10	DG. 2...
DGTR/L 20B-3D40-JHP-SL-MC	3.00	3.18	20.0	20.0	2.40	18.80	35.6	40.0	28.1	105.60	DG. 3...
DGTR/L 25B-2D35-JHP-SL-MC	1.90	2.50	25.0	25.0	1.70	24.15	32.1	35.0	33.1	117.10	DG. 2...
DGTR/L 25B-3D40-JHP-SL-MC	3.00	3.18	25.0	25.0	2.40	23.80	35.6	40.0	33.1	120.60	DG. 3...

• For insert depth capacity table and modification instructions for the holder pockets, see page 436 • For user guide, see pages 484-492

- (1) Minimum cutting width
- (2) Maximum cutting width
- (3) Maximum cutting diameter

For inserts, see pages: DGN-LF/LFT (441) • DGN-MF (442) • DGN-P (444) • DGN-UT/UA (443) • DGN-WP (444) • DGN-Z (442) • DGN/DGNC/DGNM-C (438) • DGN/DGNM-J/JS/JT (440) • DGR-P (444) • DGR-WP (445) • DGR-Z/ZS (443) • DGR/L-C DGRC/LC-C (439) • DGR/L-J/JS (441)

Spare Parts

Designation				
DGTR/L-B-D-JHP-SL-MC	SR M5-24145	PIN-32121	SW6-SD	BLD HW2.5



DGTR/L-B/BC-D

Integral Shank Reinforced Parting and Grooving Tools Especially for DGNC Type of Inserts

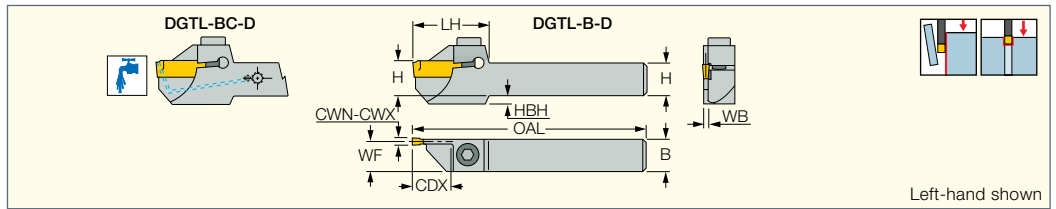

Designation	CWN ⁽³⁾	CWX ⁽⁴⁾	H	B	WB	OAL	LH	CDX ⁽⁵⁾	WF	HBH	CSP ⁽⁶⁾	Insert
DGTR/L 10B-1.4D20	1.40	1.40	10.0	10.0	1.00	140.00	23.6	10.00	9.50	2.0	0	DG. 14..
DGTR/L 12B-1.4D30	1.40	1.40	12.0	12.0	1.00	140.00	29.6	15.00	11.50	3.5	0	DG. 14..
DGTR/L 16B-1.4D30	1.40	1.40	16.0	16.0	1.00	140.00	29.6	15.00	15.50	-	0	DG. 14..
DGTR/L 20B-1.4D30	1.40	1.40	20.0	20.0	1.00	140.00	29.6	15.00	19.50	-	0	DG. 14..
DGTR/L 10B-2D30	1.90	2.50	10.0	10.0	1.60	140.00	29.6	15.00	9.20	6.6	0	DG. 1.../DG. 2..
DGTR/L 12B-2D30	1.90	2.50	12.0	12.0	1.60	140.00	29.6	15.00	11.20	3.5	0	DG. 1.../DG. 2..
DGTR/L 16B-2D32	1.90	2.50	16.0	16.0	1.60	140.00	30.6	16.00	15.20	-	0	DG. 1.../DG. 2..
DGTR/L 20B-2D35	1.90	2.50	20.0	20.0	1.60	140.00	32.1	17.50	19.20	-	0	DG. 1.../DG. 2..
DGTR/L 25B-2D35	1.90	2.50	25.0	25.0	1.60	140.00	32.1	17.50	24.20	-	0	DG. 1.../DG. 2..
DGTR/L 12B-3D30	3.00	3.18	12.0	12.0	2.40	140.00	29.6	15.00	10.80	3.5	0	DG. 1.../DG. 3..
DGTR/L 16B-3D35	3.00	3.18	16.0	16.0	2.40	140.00	32.1	16.00	14.80	2.6	0	DG. 1.../DG. 3..
DGTR/L 16BC-3D35 (1)	3.00	3.18	16.0	16.0	2.40	140.00	31.1	16.00	14.80	2.6	1	DGNC/DGRC/DGLC 3...
DGTR/L 20B-3D40 (2)	3.00	3.18	20.0	20.0	2.40	140.00	35.6	20.00	18.80	-	0	DG. 1.../DG. 3..
DGTR/L 20BC-3D40 (1)	3.00	3.18	20.0	20.0	2.40	140.00	34.6	20.00	18.80	-	1	DGNC/DGRC/DGLC 3...
DGTR/L 25B-3D40 (2)	3.00	3.18	25.0	25.0	2.40	140.00	35.6	20.00	23.80	-	0	DG. 1.../DG. 3..

• Important: 1.4 mm width inserts should be used only on tools for 1.4 mm specific width tools • DGN/R/L 1 mm inserts can also be mounted into pocket sizes 2 and 3. • For insert depth capacity table and modification instructions for the 2 and 3 holder pockets, see page 436 • For user guide, see pages 484-492

(1) Tools for inserts with coolant holes for high temperature alloys and stainless steel

(2) Insert's T_{max}=18 mm, for deeper penetration modify insert into single-ended

(3) Minimum cutting width







(4) Maximum cutting width

(5) The specified limit refers to the tool

(6) 0 - Without coolant supply, 1 - With coolant supply

For inserts, see pages: DGN-LF/LFT (441) • DGN-P (444) • DGN-UT/UA (443) • DGN-WP (444) • DGN-Z (442) • DGN/DGNC/DGNM-C (438) • DGN/DGNM-J/JS/JT (440) • DGR-P (444) • DGR-WP (445) • DGR-Z/ZS (443) • DGR/L-C DGRC/LC-C (439) • DGR/L-J/JS (441)

Spare Parts



Designation						
DGTR/L 10B-1.4D20	SR M5X12 DIN912	HW 4.0				
DGTR/L 12B-1.4D30	SR M5X12 DIN912	HW 4.0				
DGTR/L 16B-1.4D30	SR M5X12 DIN912	HW 4.0				
DGTR/L 20B-1.4D30	SR M5X12 DIN912	HW 4.0				
DGTR/L 10B-2D30	SR M5X12 DIN912	HW 4.0				
DGTR/L 12B-2D30	SR M5X12 DIN912	HW 4.0				
DGTR/L 16B-2D32	SR M4X14 DIN912	HW 3.0				
DGTR/L 20B-2D35	SR M4X14 DIN912	HW 3.0				
DGTR/L 25B-2D35	SR M5X12 DIN912	HW 4.0				
DGTR/L 12B-3D30	SR M5X12 DIN912	HW 4.0				
DGTR/L 16B-3D35	SR M5X12 DIN912	HW 4.0				
DGTR/L 16BC-3D35	SR M5X12 DIN912	HW 4.0	CGM 343*	CF 343*	SGCU 341*	CGF 343*
DGTR/L 20B-3D40	SR M5X12 DIN912	HW 4.0				
DGTR/L 20BC-3D40	SR M5X12 DIN912	HW 4.0	CGM 343*	CF 343*	SGCU 341*	CGF 343*
DGTR/L 25B-3D40	SR M5X12 DIN912	HW 4.0				

* Optional, should be ordered separately

DGTR/L-B-T-SH

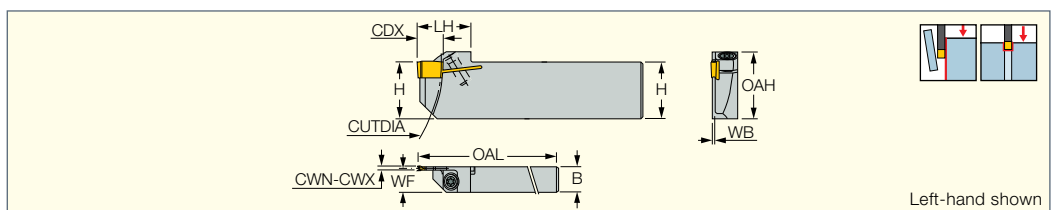
Reinforced Parting and Grooving Short Head Tools for DGN Double-Ended Inserts



Designation	CWN ⁽¹⁾	CWX ⁽²⁾	H	B	WB	WF	OAL	LH	CUTDIA	CDX ⁽³⁾	OAH		
DGTR/L 2009B-1.5T9SH	1.00	1.50	20.0	9.0	1.20	8.40	100.00	19.0	95.0	9.00	23.7	SR 16-236 P	T-15/5

• Important: 1.4 mm width inserts should be used only on tools for 1.4 mm specific width • For user guide, see pages 484-492

(1) Minimum cutting width

(2) Maximum cutting width

(3) Cutting depth maximum

For inserts, see pages: DGN-P (444) • DGN/DGNM-J/JS/JT (440) • DGR-P (444) • DGR/L-J/JS (441)

DGTR/L
Integral Shank Parting
and Grooving Tools

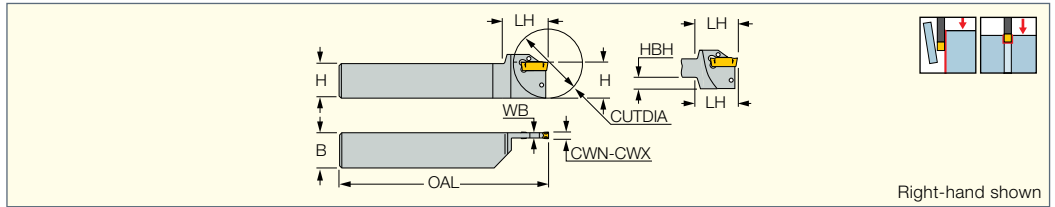

Designation	CWN ⁽¹⁾	CWX ⁽²⁾	H	B	WB	OAL	LH	HBH	CUTDIA	Insert	
DGTR/L 1010-2	1.90	2.50	10.0	10.0	1.80	150.00	29.0	6.6	35.0	DG. 1.../DG. 2..	EDG 33B*
DGTR/L 1212-2	1.90	2.50	12.0	12.0	1.80	150.00	29.0	6.6	35.0 ⁽³⁾	DG. 1.../DG. 2..	EDG 33B*
DGTR/L 1616-2	1.90	2.50	16.0	16.0	1.80	150.00	29.0	2.6	35.0 ⁽⁴⁾	DG. 1.../DG. 2..	EDG 33B*
DGTR/L 2012-2	1.90	2.50	20.0	12.0	1.80	125.00	29.0	-	35.0 ⁽³⁾	DG. 1.../DG. 2..	EDG 33A*
DGTR/L 1212-3	3.00	3.18	12.0	12.0	2.50	150.00	29.0	6.6	35.0 ⁽⁴⁾	DG. 1.../DG. 3..	EDG 33B*
DGTR/L 1616-3	3.00	3.18	16.0	16.0	2.50	150.00	29.0	6.6	35.0 ⁽⁴⁾	DG. 1.../DG. 3..	EDG 33B*
DGTR/L 2012-3	3.00	3.18	20.0	12.0	2.50	125.00	29.0	-	35.0 ⁽³⁾	DG. 1.../DG. 3..	EDG 33A*
DGTR/L 2020-3	3.00	3.18	20.0	20.0	2.50	125.00	29.0	-	35.0 ⁽³⁾	DG. 1.../DG. 3..	EDG 33A*
DGTR/L 2525-3	3.00	3.18	25.0	25.0	2.50	150.00	29.0	-	35.0 ⁽³⁾	DG. 1.../DG. 3..	EDG 33A*
DGTR/L 2020-4	4.00	4.76	20.0	20.0	3.40	125.00	31.0	-	51.0	DG. 4.../GRIP 4..	EDG 33A*
DGTR/L 2525-4	4.00	4.76	25.0	25.0	3.40	150.00	31.0	-	51.0	DG. 4.../GRIP 4..	EDG 33A*
DGTR/L 2020-5	4.80	5.00	20.0	20.0	4.00	125.00	33.0	-	59.0	DG. 5.../GRIP 5..	EDG 33A*
DGTR/L 2525-5	4.80	5.00	25.0	25.0	4.00	150.00	33.0	-	76.0	DG. 5.../GRIP 5..	EDG 33A*
DGTR/L 2525-6	6.00	6.35	25.0	25.0	5.30	150.00	33.0	-	76.0	DG. 6.../GRIP 6..	EDG 33A*

• Insert limit is T_{max}=18 mm. If deeper penetration is required, the insert should be modified into single-ended by the user • DG..1.0 insert can be mounted into pocket sizes 2 and 3, in which case the pocket width has to be modified - see page 436 • For user guide, see pages 484-492

- ⁽¹⁾ Minimum cutting width
- ⁽²⁾ Maximum cutting width
- ⁽³⁾ D_{max}=43 mm when single-ended insert is used
- ⁽⁴⁾ D_{max}=43(1.69") when single-ended insert is used

* Optional, should be ordered separately
For inserts, see pages: DGN-LF/LFT (441) • DGN-MF (442) • DGN/DGNC/DGNM-C (438) • DGR/L-C DGRC/LC-C (439) • DGN/DGNM-J/JS/JT (440) • DGR/L-J/JS (441) • DGN-P (444) • DGN-UT/UA (443) • DGN-W (439) • DGN-WP (444) • DGN-Z (442) • DGR-P (444) • DGR-WP (445) • DGR-Z/ZS (443) • GRIP (254) • GRIP (full radius) (255)
For holders, see pages: C#-ASHR/L-45-HPMC (675) • C#-ASHR/L-HPMC (675)

DGTR/L-BC-T
Parting and Grooving Tools
with Coolant Holes for DGNC
TYPE JETCUT Inserts

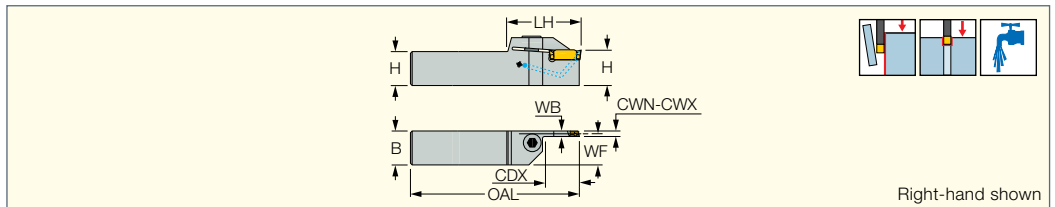







Designation	H	B	CWN ⁽¹⁾	CWX ⁽²⁾	OAL	WB	WF	LH	CDX ⁽³⁾	Insert
DGTR/L 20BC-4T25	20.0	20.0	4.00	4.00	140.00	3.40	18.30	42.0	25.00	DGNC/DGRC/DGLC 4...
DGTR/L 25BC-4T25	25.0	25.0	4.00	4.00	140.00	3.40	23.30	42.0	25.00	DGNC/DGRC/DGLC 4...

• For user guide, see pages 484-492

- ⁽¹⁾ Minimum cutting width
- ⁽²⁾ Maximum cutting width
- ⁽³⁾ Cutting depth maximum

For inserts, see pages: DGN-UT/UA (443) • DGN/DGNC/DGNM-C (438) • DGN/DGNM-J/JS/JT (440) • DGR/L-C DGRC/LC-C (439) • DGR/L-J/JS (441)
For holders, see pages: C#-ASHR/L-45-HPMC (675) • C#-ASHR/L-HPMC (675)

Spare Parts

Designation						
DGTR/L-BC-T	SR M6X16 DIN912	SGCU 341*	CGF 343*	CF 343*	CGM 343*	HW 5.0

* Optional, should be ordered separately



DGTR/L-B-D-TR
Reinforced Parting and Grooving Tools for Double-Ended DO-GRIP Inserts

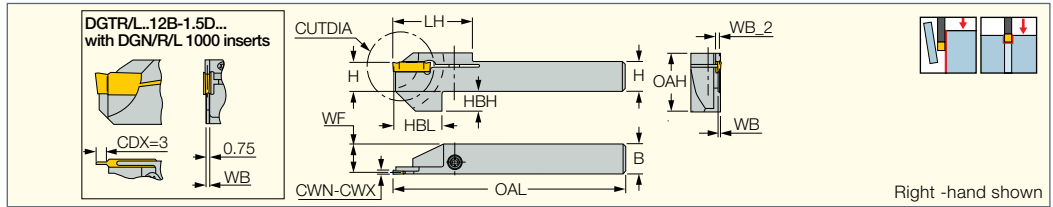

Designation	CWN ⁽¹⁾	CWX ⁽²⁾	H	B	WB	WB_2	WF	OAL	LH	HBL	CUTDIA	OAH	HBH	Insert
DGTR/L 12B-1.4D20-TR12	1.40	1.40	12.0	12.0	1.00	2.3	11.50	95.00	32.5	20.00	20.0	23.7	8.0	DG. 14..
DGTL 12B-1.5D20-TR12	1.00	1.50	12.0	12.0	1.20	2.3	11.30	95.00	32.5	20.00	20.0	23.7	8.0	DG. 1.../DG. 15..
DGTR 12B-1.5-D20-TR12	1.00	1.50	12.0	12.0	1.20	2.3	11.30	95.00	32.5	20.00	20.0	23.7	8.0	DG. 1.../DG. 15..

• Important: 1.4 mm width inserts should be used only on tools for 1.4 mm specific width! • For Traub machines, model TNL 12/7 • For user guide, see pages 484-492

⁽¹⁾ Minimum cutting width
⁽²⁾ Maximum cutting width

For inserts, see pages: DGN-P (444) • DGN/DGNM-J/JS/JT (440) • DGR-P (444) • DGR/L-J/JS (441)

Spare Parts

Designation		
DGTR/L-B-D-TR	SR 16-236 P(a)	T-15/5

(a) Recommended tightening torque: 3 N*m (26.5lb*in)



DGTR/L-XL
Integral Shank Reinforced Parting and Grooving Tools for Parting Up to 65 mm Diameters

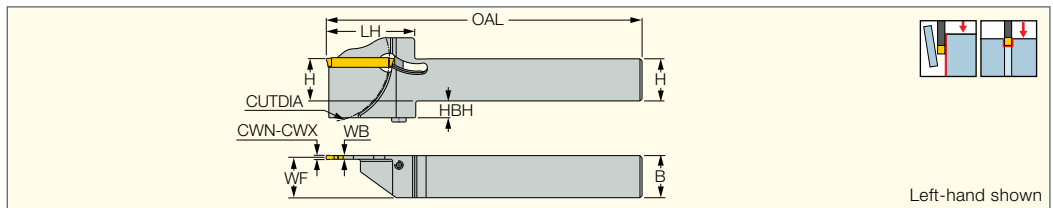

Designation	CW	CUTDIA	H	B	WB	OAL	LH	WF	HBH		
DGTR/L 20B-2XL-D60	2.00	60.0	20.0	20.0	1.74	150.00	43.2	19.10	8.0	SR M4X35DIN912	HW 3.0
DGTR/L 25B-2XL-D60	2.00	60.0	25.0	25.0	1.74	150.00	43.2	24.10	3.0	SR M4X35DIN912	HW 3.0
DGTR/L 20B-3XL-D65	3.00	65.0	20.0	20.0	2.40	150.00	43.2	18.80	12.0	SR M5X40DIN912	HW 4.0
DGTR/L 25B-3XL-D65	3.00	65.0	25.0	25.0	2.40	150.00	43.2	23.80	7.0	SR M5X40DIN912	HW 4.0

• For insert depth capacity table, see page 434 • For user guide, see pages 484-492

For inserts, see pages: DGN-C-XL (447) • DGN-J-XL (447) • DGR/L-C-XL (447) • DGR/L-J-XL (448)

Depth of Cut Function of Workpiece Diameter

T_{max}/D_{max} for DGTR/L...-2XL

T _{max}	D _{max}
15	No limit
16	600
17	300
18	200
19	150
20	130
21	120
22	100
23	90
24	85
25	80
26	75
27	70
28	65
29	63
30	60

T_{max}/D_{max} for DGTR/L...-3XL

T _{max}	D _{max}
15	No limit
16	1000
17	400
18	300
19	230
20	180
21	150
22	130
23	115
24	105
25	95
26	90
27	85
28	80
29	75
30	72
31	70
32.5	65

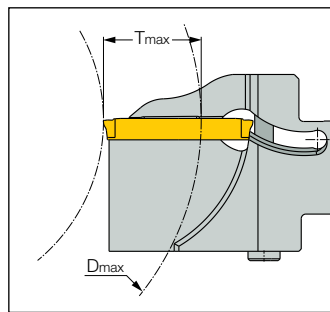

DGHAL-DECO

Holders for DGAD Adapters for
Tornos Bechler Deco Machines

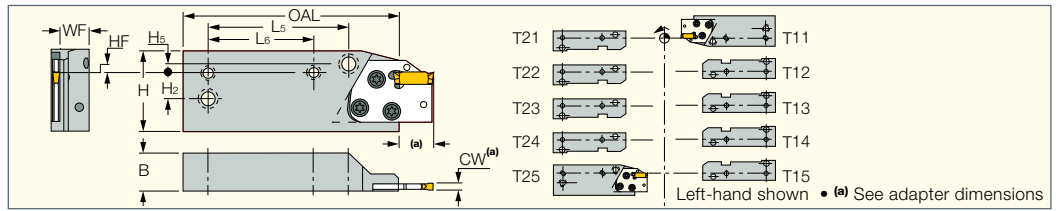

Designation	H	B	OAL	WF	HF	H ₂	H ₅	L ₆	L ₅
DGHAL DECO 7-10 ⁽¹⁾	40.3	18.2	106.00	15.0	-	12.8	4.8	52.00	69.00
DGHAL DECO 13 ⁽²⁾	42.0	35.2	115.00	28.7	2.0	16.0	16.0	60.00	60.00
DGHAL DECO 20-26 ⁽²⁾	44.8	23.2	120.00	20.0	4.0	17.0	17.0	65.00	65.00







• DGAD-... HGAD-... adapters should be ordered separately

⁽¹⁾ Positioning combinations: T11; T25

⁽²⁾ Positioning combinations: All

For tools, see pages: DGAD-B-D (436) • DGAD/HGAD (436) • SCLCR-PAD (50) • SDJCR-PAD (54) • SVJCR-PAD (60) • SWAPR-PAD (66) • TTADR/L-JHP (651)

Spare Parts



Designation							
DGHAL DECO 7-10	SR 14-519-L9.7 ^(a)	HW 4.0	SR 16-212-L9.5 ^(a)	T-20/5	SR 16-212 ^(a)	SR M5X25DIN912	
DGHAL DECO 13	SR 14-519-L9.7 ^(a)	HW 5.0	SR 16-212-L7.5 ^(a)	T-20/5	SR 16-212 ^(a)	SR M6X25 DIN912	
DGHAL DECO 20-26	SR 14-519-L12.8 ^(a)	HW 5.0	SR 16-212-L7.5 ^(a)	T-20/5	SR 16-212 ^(a)	SR M6X25 DIN912	EZ 104

(a) Recommended tightening torque:9 N*m (80lb*in)

HMSN-New Britain

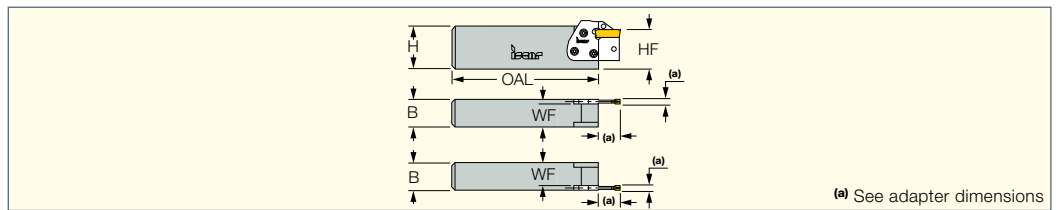
Holders for Grooving and
Turning Adapters for New Britain
Multi-Spindle Bar Machines



Designation	H	B	HF	OAL	WF	S ₁ ⁽²⁾			
HMSN 35/3722 ⁽¹⁾	36.5	22.4	34.5	181.70	18.4	226	SR 16-212	SR 14-519	T-20/5

• DGAD-... HGAD-..., adapters should be ordered separately

⁽¹⁾ For models #42; #52; #60; #61; #62; #602

⁽²⁾ Comparable Empire block

For tools, see pages: DGAD-B-D (436) • DGAD/HGAD (436) • SCLCR-PAD (50) • SDJCR-PAD (54) • SVJCR-PAD (60) • SWAPR-PAD (66) • TTADR/L-JHP (651)

DO-GRIP
 TWISTED 2-SIDED

DGAD/HGAD

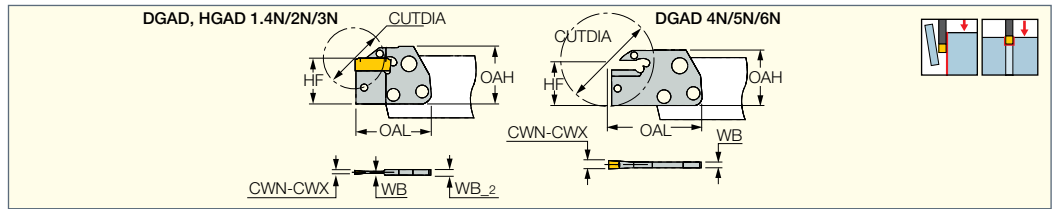
 Parting and Grooving Adapters for
 DO-GRIP Double-Ended Inserts

Designation	CWN ⁽²⁾	CWX ⁽³⁾	WB	WB_2	OAH	HF	OAL	CUTDIA	
DGAD 1.4N	1.40	1.40	1.00	3.2	30.0	24.0	41.50	28.0	EDG 23B*
DGAD 2N	1.90 ⁽⁴⁾	2.50	1.60	3.2	30.0	24.0	41.50	32.0	EDG 33A*
DGAD 3N ⁽¹⁾	3.00 ⁽⁴⁾	3.18	2.40	4.0	30.0	24.0	41.50	32.0	EDG 33A*
HGAD 3N	3.00	3.00	2.40	4.0	30.0	24.0	50.50	50.0	EDG 23B*
DGAD 4N	4.00	4.00	3.20	-	30.0	24.0	50.50	50.0	EDG 33A*
DGAD 5N	4.80	5.00	4.00	-	30.0	24.0	50.50	50.0	EDG 33A*
DGAD 6N	6.00	6.35	5.20	-	30.0	24.0	50.50	50.0	EDG 33A*

• DG..1.0 insert can be mounted into pocket sizes 2 and 3 in which case the pocket width has to be modified - see page 436 • For user guide, see pages 484-492

⁽¹⁾ Only the DGN/R/L inserts are suitable for this adapter

⁽²⁾ Minimum cutting width

⁽³⁾ Maximum cutting width

⁽⁴⁾ For 1 mm inserts, modify adapter

* Optional, should be ordered separately

For inserts, see pages: DGN-P (444) • DGN-UT/UA (443) • DGN-W (439) • DGN-WP (444) • DGN-Z (442) • DGN/DGNC/DGNM-C (438) • DGN/DGNM-J/JS/JT (440) • DGR-P (444) • DGR-WP (445) • DGR-Z/ZS (443) • DGR/L-C DGRC/LC-C (439) • DGR/L-J/JS (441) • GRIP (254) • GRIP (full radius) (255) • HGN-C (445) • HGN-J (446) • HGN-UT (446) • HGR/L-C (445) • HGR/L-J/JS (446)

For holders, see pages: MAHPR/L-JHP (264) • MAHR/L-JHP (263) • MAHR/L (262) • MAHPR/L (264) • C#-MAHD (592) • C#-MAHPD (593) • C#-MAHUR/L (592) • C#-MAHDR-45 (591) • C#-MAHDOR (592) • HSK A63WH-MAHUR/L (598) • HSK A63WH-MAHDR-45 (597) • HSK A63WH-MAHDOR (597) • IM-MAHD (599) • IM-MAHPD (599) • C#-MAHD-JHP (593) • C#-MAHPD-JHP (593) • MAHR/L-JHP-MC (263) • HMSN-New Britain (435) • DGHAL-DECO (435)

Depth Capacity for DGN/R-1002J Insert on Standard Holders

Depth: T	D max	Depth: T	D max
Up to	No limit	Up to	32.3
1.2	830	2.3	29.3
1.3	218	2.4	26.7
1.4	126	2.5	24.8
1.5	88.4	2.6	23.2
1.6	68.2	2.7	21.7
1.7	55.6	2.8	20.5
1.8	46.9	2.9	19.4
1.9	40.7	3.0	18.4
2.0	36.0		
2.1			

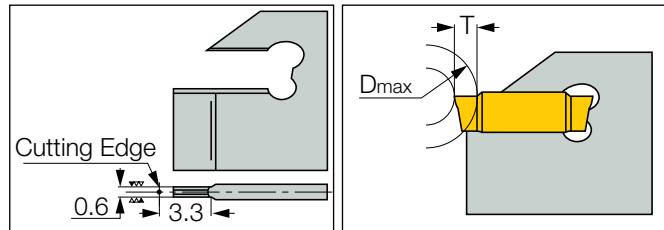
Standard Holders Modification

To achieve no limitation on the workpiece diameter up to 3 mm depth, the steel support under the insert should be ground, as per the shown sketch.

DO-GRIP
 TWISTED 2-SIDED

DGAD-B-D

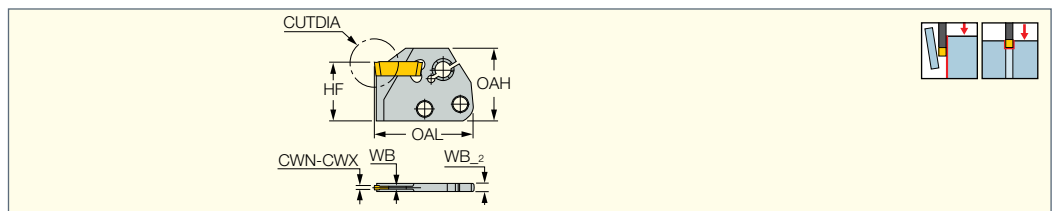
 Parting and Grooving Screw-
 Clamped Adapters for DO-GRIP
 Double-Ended Inserts

Designation	CWN ⁽²⁾	CWX ⁽³⁾	WB	WB_2	OAL	CUTDIA	HF	OAH
DGAD 1.4B-D16	1.40	1.40	1.00	3.2	36.80	16.0	24.0	30.3
DGAD 1.5B-D20 ⁽¹⁾	1.00	1.50	1.00	3.2	41.00	20.0	24.0	30.3
DGAD 2B-D20	1.90	2.50	1.60	3.2	41.00	20.0	24.0	30.3

• Up to 3 mm depth, without any limitation on the diameter • DG..1.0 insert can also be mounted into pocket sizes 2 and 3, in which case the pocket width has to be modified-see page 436 • For user guide, see pages 484-492

⁽¹⁾ Do not use DG.. 1.4 on this tool!

⁽²⁾ Minimum cutting width

⁽³⁾ Maximum cutting width

For inserts, see pages: DGN-LF/LFT (441) • DGN-P (444) • DGN-UT/UA (443) • DGN-WP (444) • DGN-Z (442) • DGN/DGNC/DGNM-C (438) • DGN/DGNM-J/JS/JT (440) • DGR-P (444) • DGR-WP (445) • DGR-Z/ZS (443) • DGR/L-C DGRC/LC-C (439) • DGR/L-J/JS (441)

For holders, see pages: C#-MAHD-JHP (593) • C#-MAHPD-JHP (593) • MAHR/L-JHP-MC (263) • MAHPR/L-JHP (264) • MAHR/L-JHP (263) • MAHR/L (262) • MAHPR/L (264) • C#-MAHD (592) • C#-MAHPD (593) • C#-MAHUR/L (592) • C#-MAHDR-45 (591) • C#-MAHDOR (592) • HSK A63WH-MAHUR/L (598) • HSK A63WH-MAHDR-45 (597) • HSK A63WH-MAHDOR (597) • IM-MAHD (599) • IM-MAHPD (599) • HMSN-New Britain (435) • DGHAL-DECO (435)

D/HGAD RE/LE-JHP
Parting and Grooving Adapters
with Channels for High Pressure
Coolant Carrying DO-GRIP Inserts

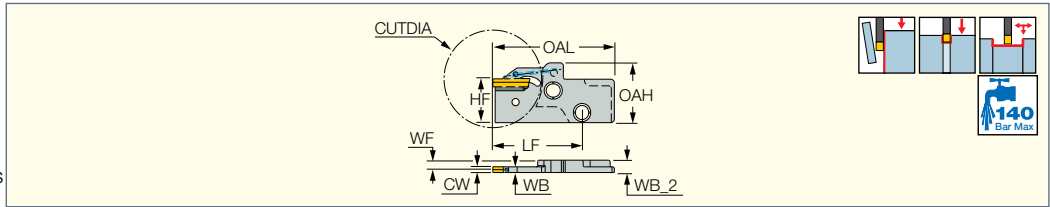

Designation	CWN ⁽²⁾	CWX ⁽³⁾	WF	WB	WB_2	LF	OAL	OAH	HF	CUTDIA	Insert
DGAD 2R/LE-D38-JHP (1)	1.90	2.50	4.50	1.60	5.3	40.40	54.35	25.8	18.9	38.0	DGN 2
DGAD 3LE-D38-JHP (1)	3.00	3.18	4.08	2.45	5.3	40.40	54.35	25.8	18.9	38.0	DGN 3
HGAD 3R/LE-D42-JHP	3.00	3.00	4.08	2.45	5.3	38.40	52.35	25.8	18.9	42.0	HGN 3/GRIP 3

• For user guide and accessories, see pages 484-492

(1) For parting and external grooving only

(2) Minimum cutting width

(3) Maximum cutting width

For inserts, see pages: DGN-P (444) • DGN-UT/UA (443) • DGN-WP (444) • DGN-Z (442) • DGN/DGNC/DGNM-C (438) • DGN/DGNM-J/JS/JT (440) • DGR-P (444) • DGR-WP (445) • DGR-Z/ZS (443) • DGR/L-C DGRC/LC-C (439) • DGR/L-J/JS (441) • GRIP (254) • GRIP (full radius) (255) • HGN-C (445) • HGN-J (446) • HGN-UT (446) • HGR/L-C (445) • HGR/L-J/JS (446)

For holders, see pages: NMAHR/L-JHP (458)

Spare Parts

Designation	
DGAD 2LE-D38-JHP	EDG 33A*
DGAD 2RE-D38-JHP	EDG 33A*
DGAD 3LE-D38-JHP	EDG 33A*
DGAD 3RE-D38-JHP	EDG 33A*
HGAD 3LE-D42-JHP	EDG 23B*
HGAD 3RE-D42-JHP	EDG 23B*

* Optional, should be ordered separately

DGPAD-JHP
Adapters with High Pressure
Coolant Channels for DO-GRIP
Parting and Grooving Inserts

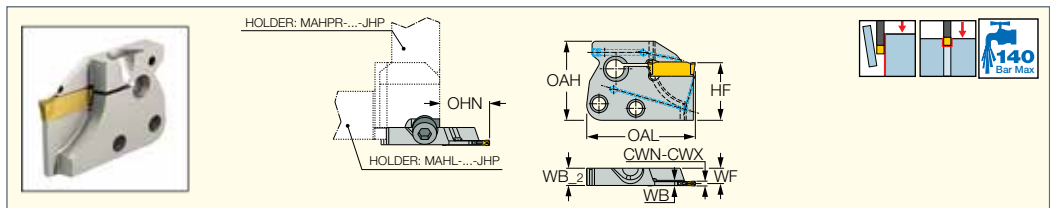

Designation	CWN ⁽¹⁾	CWX ⁽²⁾	CUTDIA	OHN ⁽³⁾	WF	WB	WB_2	OAL	OAH	HF	Insert
DGPAD 2R/L-D22-JHP	1.90	2.50	22.0	21.0	6.40	1.60	7.2	45.50	33.0	24.0	DG. 2...
DGPAD 2R/L-D32-JHP	1.90	2.50	32.0	21.0	6.40	1.60	7.2	45.50	33.0	24.0	DG. 2...
DGPAD 3L-D32-JHP	3.00	3.18	32.0	21.0	6.00	2.40	7.2	45.50	33.0	24.0	DG. 3...

• For user guide and accessories, see pages 484-492

(1) Minimum cutting width

(2) Maximum cutting width

(3) Minimum overhang

For inserts, see pages: DGN-LF/LFT (441) • DGN-MF (442) • DGN-P (444) • DGN-UT/UA (443) • DGN-WP (444) • DGN-Z (442) • DGN/DGNC/DGNM-C (438) • DGN/DGNM-J/JS/JT (440) • DGR-P (444) • DGR-WP (445) • DGR-Z/ZS (443) • DGR/L-C DGRC/LC-C (439) • DGR/L-J/JS (441)

For holders, see pages: ABC MAHDR-#-XL-JHP (532) • BI## MAHD#-#-XL-JHP (525) • BMT## MAHD#-#-XL-JHP (520) • C# MAHD#-#-XL-JHP (523) • HSK T ## MAHD#-#-XL-JHP (524) • MA##### MAHD#-#-XL-JHP (522) • MI## MAHD#-#-XL-JHP (526) • MORI## MAHD#-#-XL-JHP (521) • MS##-##-MG-JHP (501) • MS-ES##### GWS-MG-JHP (502) • NT## MAHD#-#-XL-JHP (527) • OKUMA # MAHD#-#-XL-JHP (528) • TR45 MAHDR-#-XL-JHP (530) • V## MAHD#-#-XL-##-JHP (529) • V## MAHD-XL-JHP (530) • VDI##### MAHD#-#-XL-JHP (518) • VDI###-P MAHD#-#-XL-JHP (519)

Flow Rate vs. Pressure

Designation	70 Bar	100 Bar	140 Bar
	Flow Rate (liters/min)	Flow Rate (liters/min)	Flow Rate (liters/min)
DGPAD 2R/L-D22-JHP	5	6	7
DGPAD 2R/L-D32-JHP	5	6	7
DGPAD 3R/L-D32-JHP	8.5	10	12

DGPAD-XL-JHP
Parting and Grooving Extra
Long Adapters with Coolant
Channels for DO-GRIP Inserts

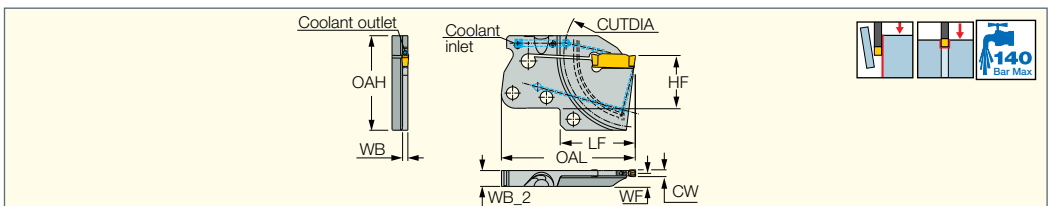

Designation	CW	CUTDIA	WF	WB	WB_2	LF	OAL	OAH	HF	Insert
DGPAD-XL 3R/L-D52-JHP	3.00	52.0	6.00	2.40	7.2	27.70	54.40	43.0	34.0	DG. 3...
DGPAD-XL 3R/L-D65-JHP	3.00	65.0	6.00	2.40	7.2	34.20	60.40	43.0	34.0	DG. 3...

• For user guide and accessories, see pages 484-492

For inserts, see pages: DGN-LF/LFT (441) • DGN-MF (442) • DGN-P (444) • DGN-UT/UA (443) • DGN-Z (442) • DGN/DGNC/DGNM-C (438) • DGN/DGNM-J/JS/JT (440) • DGR-Z/ZS (443) • DGR/L-C DGRC/LC-C (439) • DGR/L-J/JS (441)

For holders, see pages: ABC MAHDR-#-XL-JHP (532) • MAHR/L-MG-XL-JHP (457) • MAHR/L-MG-XL-JHP-MC (457) • TR TNK36 MAHDL-R-XL-JHP (531) • TR45TNL MAHDL-R-XL-JHP (531)



DGN/DGNC/DGNM-C
 Double-Sided Parting Inserts for Parting and Grooving Bars, Hard Materials and Tough Applications

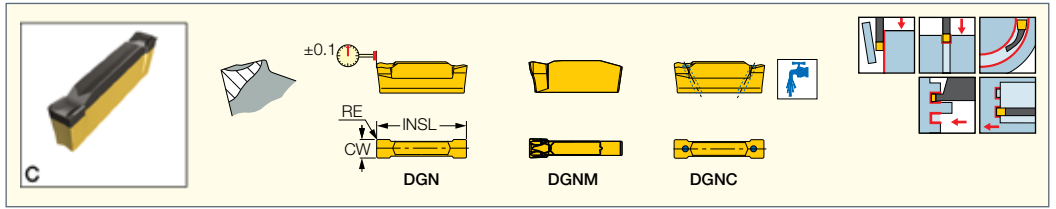

Designation	Dimensions						Tough ↔ Hard												Recommended Machining Data				
	CW	CWTOL ⁽⁹⁾	RE	RETOL ⁽⁴⁾	CDX ⁽⁵⁾	INSL	IC328	IC880	IC928	IC1030	IC1028	IC354	IC5400	IC1010	IC308	IC808	IC908	IC30N		IC20	IC807	IC907	f groove (mm/rev)
DGN 2002C	2.00	0.03	0.20	0.020	18.00	19.90	•	•		•	•	•	•	•	•	•	•	•	•	•	•	•	0.05-0.16
DGN 2202C	2.20	0.03	0.20	0.020	18.00	19.80	•	•		•	•	•	•	•	•	•	•	•	•	•	•	•	0.05-0.16
DGN 2502C	2.50	0.03	0.20	0.020	18.00	20.70			•	•	•	•	•	•	•	•	•	•	•	•	•	•	0.08-0.20
DGN 3102C	3.10	0.04	0.20	0.020	18.00	20.10	•	•		•	•	•	•	•	•	•	•	•	•	•	•	•	0.10-0.25
DGNC 3102C ⁽¹⁾	3.10	0.04	0.20	0.020	18.00	21.00									•	•	•	•	•	•	•	•	0.10-0.25
DGNM 3202C ⁽²⁾	3.18	0.04	0.20	0.020	- ⁽⁶⁾	20.40	•				•					•	•	•	•	•	•	•	0.10-0.25
DGN 4003C	4.00	0.04	0.30	0.030	- ⁽⁶⁾	18.80	•	•		•	•			•	•	•	•	•	•	•	•	•	0.10-0.30
DGNC 4003C ⁽¹⁾	4.00	0.04	0.30	0.030	- ⁽⁶⁾	19.00									•	•	•	•	•	•	•	•	0.10-0.30
DGN 4803C	4.80	0.04	0.30	0.030	- ⁽⁶⁾	19.90	•									•	•	•	•	•	•	•	0.12-0.35
DGN 5003C	5.00	0.04	0.30	0.030	- ⁽⁶⁾	19.10	•	•		•	•				•	•	•	•	•	•	•	•	0.12-0.35
DGN 6303C	6.35	0.04	0.35	0.030	- ⁽⁶⁾	19.10	•	•		•	•				•	•	•	•	•	•	•	•	0.15-0.40

• Feed values for grade IC20 should be decreased by 50% • For cutting speed recommendations and user guide, see pages 484-492

⁽¹⁾ Inserts with coolant holes, recommended coolant pressure 10 bar minimum

⁽²⁾ Single-ended insert.

⁽³⁾ Cutting width tolerance (+/-)

⁽⁴⁾ Corner radius tolerance (+/-)

⁽⁵⁾ Cutting depth maximum

⁽⁶⁾ No depth limit

For tools, see pages: C#-HELIR/L (249) • C#-HFIR/L-MC (555) • CR HFIR-M (557) • D/HGAD RE/LE-JHP (437) • DGAD-B-D (436) • DGAD/HGAD (436) • DGFH (252) • DGFH-JHP (253) • DGFHL-26B-TR-D (428) • DGFHR/L (426) • DGFHR/L-B-D..(R/L) (428) • DGFHR/L-BC-JHP (427) • DGFS (427) • DGPAD-JHP (437) • DGPAD-XL-JHP (437) • DGTR/L (433) • DGTR/L-B-D-JHP-SL (430) • DGTR/L-B-D-JHP-SL-MC (431) • DGTR/L-B-D-SH (429) • DGTR/L-B/BC-D (432) • DGTR/L-BC-T (433) • HELIR/L (250) • HFAER/L-4 (551) • HFAER/L-5T, 6T (552) • HFAIR/L-4 (554) • HFAIR/L-DG (555) • HFFR/L-T (550) • HFHR/L-4T (548) • HFHR/L-5T (548) • HFHR/L-6T (549) • HFIR/L-MC (556) • HFPAD-4 (549) • HFPAD-5 (550) • HFPAD-6 (550) • HGPAD (251) • HGPAD-JHP (251) • IM-HFIR-MC (556)



DGR/L-C DGRC/LC-C
Double-Sided Inserts for Parting Bars, Hard Materials and Tough Applications

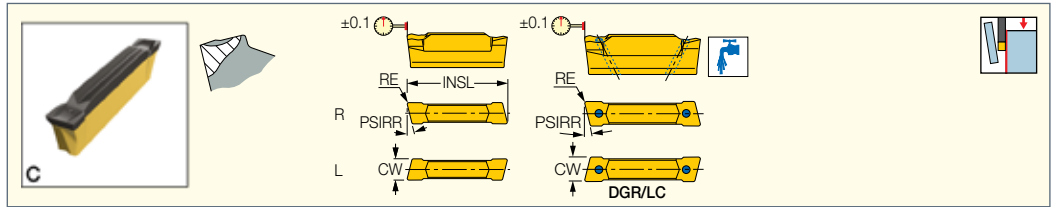

Designation	Dimensions						Tough ↔ Hard							Recommended Machining Data
	CW	RE	CDX ⁽²⁾	PSIRL	PSIRR	INSL	IC328	IC830	IC1028	IC354	IC808	IC908	IC20	
DGL 2202C-6D	2.20	0.20	18.00	6.0	-	20.80	●		●	●		●	●	0.04-0.12
DGR 2202C-6D	2.20	0.20	18.00	-	6.0	20.80	●	●	●	●	●	●	●	0.04-0.12
DGL 3102C-15D	3.10	0.20	18.00	15.0	-	21.00	●	●	●					0.08-0.14
DGL 3102C-6D	3.10	0.20	18.00	6.0	-	21.00	●	●	●	●	●	●	●	0.08-0.18
DGLC 3102C-6D ⁽¹⁾	3.10	0.20	18.00	6.0	-	21.00					●	●		0.08-0.18
DGR 3102C-15D	3.10	0.20	18.00	-	15.0	20.90	●	●	●					0.08-0.14
DGR 3102C-6D	3.10	0.20	18.00	-	6.0	21.00	●	●	●	●	●	●	●	0.08-0.18
DGR 3102C-8D	3.10	0.20	18.00	-	8.0	21.10	●	●	●					0.05-0.15
DGRC 3102C-6D ⁽¹⁾	3.10	0.20	18.00	-	6.0	20.90					●	●		0.08-0.18
DGL 4003C-4D	4.00	0.30	- ⁽³⁾	4.0	-	18.90	●		●	●		●	●	0.08-0.20
DGLC 4003C-4D ⁽¹⁾	4.00	0.30	- ⁽³⁾	4.0	-	19.00					●			0.08-0.20
DGR 4003C-4D	4.00	0.30	- ⁽³⁾	-	4.0	18.80	●	●	●	●		●	●	0.08-0.20
DGRC 4003C-4D ⁽¹⁾	4.00	0.30	- ⁽³⁾	-	4.0	19.00					●	●		0.08-0.20
DGR 4800CS-4D	4.80	0.02	- ⁽³⁾	-	4.0	19.70	●							0.05-0.15
DGR 4800CS-8D	4.80	0.02	- ⁽³⁾	-	8.0	19.70	●							0.05-0.15
DGR 4803C-4D	4.80	0.30	- ⁽³⁾	-	4.0	20.30	●							0.10-0.25
DGR 4803C-8D	4.80	0.30	- ⁽³⁾	-	8.0	20.30	●							0.10-0.20
DGL 5003C-4D	5.00	0.30	- ⁽³⁾	4.0	-	19.10	●			●			●	0.10-0.25
DGR 5003C-4D	5.00	0.30	- ⁽³⁾	-	4.0	19.20	●							0.10-0.25
DGL 6303C-4D	6.35	0.35	- ⁽³⁾	4.0	-	19.10	●			●			●	0.12-0.30
DGR 6303C-4D	6.35	0.35	- ⁽³⁾	-	4.0	19.10	●			●			●	0.12-0.30

• Feed values for grade IC20 should be decreased by 50% • For cutting speed recommendations and user guide, see pages 484-492

⁽¹⁾ Inserts with coolant holes, recommended coolant pressure 10 bar minimum

⁽²⁾ Cutting depth maximum

⁽³⁾ No depth limit

For tools, see pages: C#-HELIR/L (249) • D/HGAD RE/LE-JHP (437) • DGAD-B-D (436) • DGAD/HGAD (436) • DGFH (252) • DGFH-JHP (253) • DGFHL-26B-TR-D (428) • DGFHR/L (426) • DGFHR/L-B-D..(R/L) (428) • DGFHR/L-BC-JHP (427) • DGFS (427) • DGPAD-JHP (437) • DGPAD-XL-JHP (437) • DGTR/L (433) • DGTR/L-B-D-JHP-SL (430) • DGTR/L-B-D-JHP-SL-MC (431) • DGTR/L-B-D-SH (429) • DGTR/L-B/BC-D (432) • DGTR/L-BC-T (433) • HELIR/L (250)

DGN-W
Double-Sided Inserts with Central Ridged Chipformer for Parting and Grooving Hard Materials and Interrupted Cuts

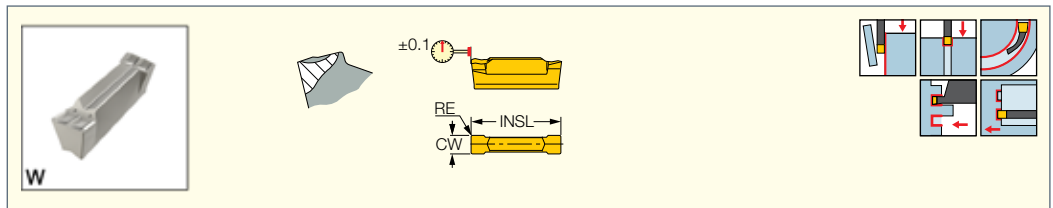

Designation	Dimensions					Tough ↔ Hard		Recommended Machining Data
	CW	RE	CWTOL ⁽¹⁾	RETOL ⁽²⁾	INSL	IC328	IC354	
DGN 5003W	5.00	0.30	0.04	0.030	19.00	●	●	0.12-0.33

• No depth limit • For cutting speed recommendations and user guide, see pages 484-492

⁽¹⁾ Cutting width tolerance (+/-)

⁽²⁾ Corner radius tolerance (+/-)

For tools, see pages: C#-HELIR/L (249) • C#-HFIR/L-MC (555) • CR HFIR-M (557) • DGAD/HGAD (436) • DGFH (252) • DGFH-JHP (253) • DGTR/L (433) • HELIR/L (250) • HFAER/L-5T, 6T (552) • HFAIR/L-DG (555) • HFFR/L-T (550) • HFHR/L-5T (548) • HFIR/L-MC (556) • HFPAD-5 (550) • HGPAD (251) • HGPAD-JHP (251) • IM-HFIR-MC (556)

DOGRIP
TWISTED 2-SIDED**DGN/DGNM-J/JS/JT**

Double-Sided Inserts for Parting and Grooving Soft Materials, Parting Tubes, Small Diameters and Thin-Walled Parts

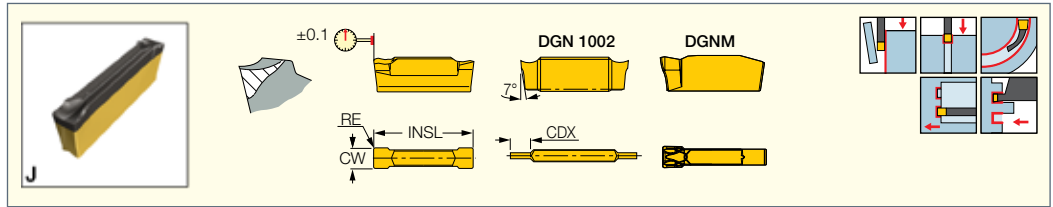

Designation	Dimensions						Tough ↔ Hard											Recommended Machining Data				
	CW	CWTOL ⁽³⁾	RE	RETOL ⁽⁴⁾	CDX ⁽⁵⁾	INSL	IC328	IC830	IC928	IC1030	IC1028	IC354	IC5400	IC1010	IC308	IC808	IC908		IC20	IC807	IC907	f groove (mm/rev)
DGN 1002J	1.00	0.02	0.16	0.020	3.00	21.00	•				•						•					0.02-0.07
DGN 1402J	1.40	0.03	0.16	0.020	15.00	15.80	•	•			•	•			•	•	•					0.03-0.12
DGN 1502J	1.50	0.03	0.16	0.020	18.00	20.90	•				•						•					0.03-0.12
DGN 2002JT	2.00	0.03	0.20	0.020	18.00	19.80										•						0.04-0.14
DGN 2200JS ⁽¹⁾	2.20	0.03	0.02	0.020	18.00	19.40	•	•														0.03-0.08
DGN 2202J	2.20	0.03	0.20	0.020	18.00	19.80	•	•		•	•	•	•	•	•	•	•	•	•	•		0.04-0.12
DGN 2202JT	2.20	0.03	0.20	0.020	18.00	19.80		•				•			•							0.04-0.14
DGN 3100JS ⁽¹⁾	3.10	0.04	0.02	0.020	18.00	19.70	•								•							0.03-0.10
DGN 3102J	3.10	0.04	0.20	0.020	18.00	20.10	•	•		•	•	•	•	•	•	•	•	•	•	•		0.04-0.16
DGN 3102JT	3.10	0.04	0.20	0.020	18.00	20.10		•				•			•					•		0.05-0.18
DGN 3202J	3.18	0.04	0.20	0.020	18.00	20.10											•					0.04-0.16
DGNM 3202J ⁽²⁾	3.18	0.04	0.20	0.020	- ⁽⁶⁾	20.30	•					•				•						0.04-0.16
DGN 4003J	4.00	0.04	0.30	0.030	- ⁽⁶⁾	18.90	•	•			•	•			•	•	•	•	•			0.05-0.18
DGN 4003JT	4.00	0.04	0.30	0.030	- ⁽⁶⁾	18.90		•														0.05-0.18
DGN 4803J	4.80	0.04	0.30	0.030	- ⁽⁶⁾	20.40	•															0.05-0.20
DGN 5003J	5.00	0.04	0.30	0.030	- ⁽⁶⁾	19.00	•	•			•	•				•	•	•				0.05-0.20
DGN 5003JT	5.00	0.04	0.30	0.030	- ⁽⁶⁾	19.00			•								•	•				0.05-0.20
DGN 6303J	6.35	0.04	0.35	0.030	- ⁽⁶⁾	19.10	•	•			•	•				•	•	•				0.05-0.25
DGN 6303JT	6.35	0.04	0.35	0.030	- ⁽⁶⁾	19.10			•								•	•				0.05-0.25

• JT chipformer has the basic positive configuration of the J-type and a reinforced negative frontal edge; most suitable for soft materials at low to medium feeds • For cutting speed recommendations and user guide, see pages 484-492

(1) Sharp corners

(2) Single-ended insert

(3) Cutting width tolerance (+/-)

(4) Corner radius tolerance (+/-)

(5) Cutting depth maximum

(6) No depth limit

For tools, see pages: C#-HELIR/L (249) • C#-HFIR/L-MC (555) • CR HFIR-M (557) • D/HGAD RE/LE-JHP (437) • DGAD-B-D (436) • DGAD/HGAD (436) • DGFH (252) • DGFH-JHP (253) • DGFHL-26B-TR-D (428) • DGFHR/L (426) • DGFHR/L-B-D..(R/L) (428) • DGFHR/L-BC-JHP (427) • DGFS (427) • DGPAD-JHP (437) • DGPAD-XL-JHP (437) • DGTR/L (433) • DGTR/L-B-D-JHP-SL (430) • DGTR/L-B-D-JHP-SL-MC (431) • DGTR/L-B-D-SH (429) • DGTR/L-B-D-TR (434) • DGTR/L-B-T-SH (432) • DGTR/L-B/BC-D (432) • DGTR/L-BC-T (433) • HELIR/L (250) • HFAER/L-4 (551) • HFAER/L-5T, 6T (552) • HFAIR/L-4 (554) • HFAIR/L-DG (555) • HFFR/L-T (550) • HFHR/L-4T (548) • HFHR/L-5T (548) • HFHR/L-6T (549) • HFIR/L-MC (556) • HFPAD-4 (549) • HFPAD-5 (550) • HFPAD-6 (550) • HGPAD (251) • HGPAD-JHP (251) • IM-HFIR-MC (556)



DGR/L-J/JS

Double-Sided Inserts for Parting Soft Materials, Parting Tubes, Small Diameters and Thin-Walled Parts

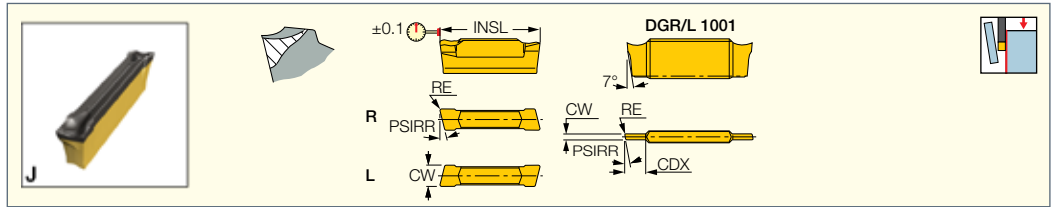

Designation	Dimensions						Tough ↔ Hard								Recommended Machining Data f groove (mm/rev)
	CW	RE	CDX ⁽²⁾	INSL	PSIRL	PSIRR	IC328	IC830	IC1028	IC354	IC308	IC808	IC908	IC20	
DGL 1001J-8D	1.00	0.07	3.00	21.00	8.0	-									0.02-0.06
DGR 1001J-8D	1.00	0.07	3.00	21.00	-	8.0	●		●		●		●		0.02-0.06
DGL 1400JS-15D ⁽¹⁾	1.40	0.02	14.00	15.40	15.0	-									0.03-0.07
DGR 1402J-8D	1.40	0.16	14.00	15.40	-	15.0	●		●						0.03-0.08
DGR 1400JS-15D ⁽¹⁾	1.40	0.02	14.00	15.80	8.0	-	●	●	●		●		●		0.03-0.07
DGR 1402J-8D	1.40	0.16	14.00	15.80	-	8.0	●	●	●		●		●		0.03-0.08
DGR 1500J-8D	1.50	0.05	18.00	20.90	-	8.0	●	●	●		●				0.03-0.08
DGL 2200JS-15D ⁽¹⁾	2.20	0.02	18.00	20.60	15.0	-									0.03-0.07
DGR 2200JS-6D ⁽¹⁾	2.20	0.02	18.00	20.60	6.0	-	●		●		●		●		0.03-0.08
DGL 2202J-6D	2.20	0.20	18.00	21.00	-	15.0	●		●	●			●	●	0.03-0.10
DGR 2200JS-15D ⁽¹⁾	2.20	0.02	18.00	20.60	-	6.0	●		●	●			●	●	0.03-0.07
DGR 2200JS-6D ⁽¹⁾	2.20	0.02	18.00	20.60	6.0	-	●	●	●		●		●		0.03-0.08
DGR 2202J-15D	2.20	0.20	18.00	21.00	-	15.0	●	●	●						0.03-0.08
DGR 2202J-6D	2.20	0.20	18.00	21.00	-	6.0	●	●	●				●	●	0.03-0.10
DGL 3100JS-15D ⁽¹⁾	3.10	0.02	18.00	20.60	15.0	-	●		●	●			●		0.03-0.07
DGL 3100JS-6D ⁽¹⁾	3.10	0.02	18.00	20.60	6.0	-	●		●		●		●		0.03-0.08
DGL 3102J-15D	3.10	0.20	18.00	21.00	-	15.0	●		●						0.04-0.10
DGL 3102J-6D	3.10	0.20	18.00	21.00	-	6.0	●	●	●	●			●	●	0.04-0.14
DGR 3100JS-15D ⁽¹⁾	3.10	0.02	18.00	20.60	15.0	-	●	●	●		●		●		0.03-0.07
DGR 3100JS-6D ⁽¹⁾	3.10	0.02	18.00	20.60	6.0	-	●	●	●	●			●	●	0.03-0.08
DGR 3102J-15D	3.10	0.20	18.00	21.00	-	15.0	●		●	●			●		0.04-0.10
DGR 3102J-6D	3.10	0.20	18.00	21.00	-	6.0	●	●	●			●	●	●	0.04-0.14
DGL 4003J-4D	4.00	0.30	- ⁽³⁾	19.90	-	15.0	●		●	●			●	●	0.04-0.15
DGR 4000JS-15D ⁽¹⁾	4.00	0.00	- ⁽³⁾	19.30	4.0	-	●								0.04-0.10
DGR 4003J-4D	4.00	0.30	- ⁽³⁾	19.90	-	4.0	●	●	●			●	●	●	0.04-0.15
DGR 4800JS-4D ⁽¹⁾	4.80	0.03	- ⁽³⁾	19.80	-	4.0	●								0.04-0.12
DGR 4800JS-8D ⁽¹⁾	4.80	0.03	- ⁽³⁾	19.80	-	8.0	●								0.04-0.14
DGR 4803J-4D	4.80	0.30	- ⁽³⁾	19.80	-	4.0	●								0.04-0.18
DGR 4803J-8D	4.80	0.30	- ⁽³⁾	19.80	-	8.0	●								0.04-0.15
DGL 5003J-4D	5.00	0.30	- ⁽³⁾	19.80	4.0	-	●			●					0.05-0.20
DGR 5003J-4D	5.00	0.30	- ⁽³⁾	19.80	-	4.0	●			●				●	0.05-0.20
DGL 6303J-4D	6.35	0.35	- ⁽³⁾	19.10	4.0	-	●			●				●	0.05-0.25
DGR 6303J-4D	6.35	0.35	- ⁽³⁾	19.10	-	4.0	●			●					0.05-0.25

• For cutting speed recommendations and user guide, see pages 484-492

⁽¹⁾ Sharp corners

⁽²⁾ Cutting depth maximum

⁽³⁾ No depth limit.

DGN-LF/LFT

Double-Sided Inserts for Parting and Grooving Stainless Steel

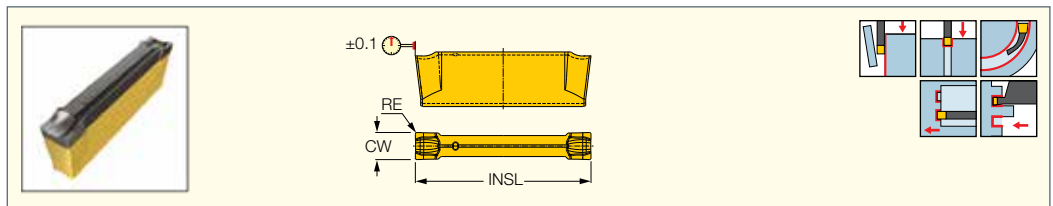

Designation	Dimensions						Tough ↔ Hard								Recommended Machining Data f groove (mm/rev)
	CW	CWTOL ⁽¹⁾	RE	RETOL ⁽²⁾	CDX ⁽³⁾	INSL	IC830	IC928	IC1030	IC5-400	IC1010	IC808	IC908		
DGN 2002LF	2.00	0.03	0.20	0.020	18.00	19.80	●				●	●	●		0.03-0.08
DGN 2202LF	2.20	0.03	0.20	0.020	18.00	19.80		●	●						0.03-0.08
DGN 3102LF	3.10	0.04	0.20	0.020	18.00	20.10	●		●	●			●	●	0.04-0.10
DGN 3102LFT	3.10	0.04	0.20	0.020	18.00	21.10		●						●	0.04-0.12

• The LFT chipformer features basically the same design as the LF chipformer, except that it was reinforced by a T-land to improve its durability in interrupted-cut or on hard materials applications. It can be applied at higher feeds than the LF chipformer

⁽¹⁾ Cutting width tolerance (+/-)

⁽²⁾ Corner radius tolerance (+/-)

⁽³⁾ Cutting depth maximum

For tools, see pages: DGAD-B-D (436) • DGFH (252) • DGFH-JHP (253) • DGFHL-26B-TR-D (428) • DGFHR/L (426) • DGFHR/L-B-D..(R/L) (428) • DGFHR/L-BC-JHP (427) • DGFS (427) • DGPAD-JHP (437) • DGPAD-XL-JHP (437) • DGTR/L (433) • DGTR/L-B-D-JHP-SL (430) • DGTR/L-B-D-JHP-SL-MC (431) • DGTR/L-B-D-SH (429) • DGTR/L-B/BC-D (432)

DO GRIP
TWISTED 2-SIDED**DGN-MF**

Double-Sided Inserts for Parting and Grooving Soft and Hard Materials at Medium Feeds

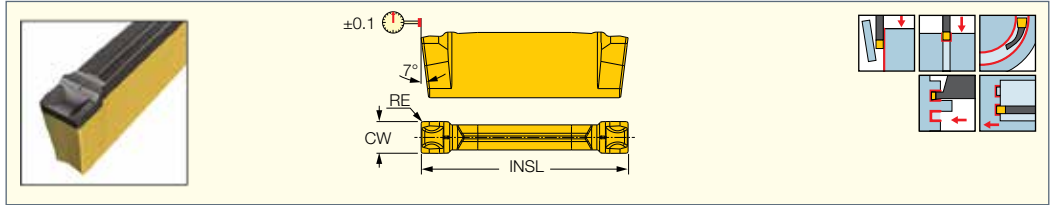

Designation	Dimensions					Tough ↔ Hard					Recommended Machining Data f groove (mm/rev)
	CW	RE	CWTOL ⁽¹⁾	CDX ⁽²⁾	INSL	IC830	IC1030	IC5400	IC1010	IC808	
DGN 2002MF	2.00	0.20	0.04	18.00	19.90	●	●	●	●	●	0.04-0.12
DGN 2202MF	2.20	0.20	0.04	18.00	19.90		●		●		0.04-0.12
DGN 3002MF	3.00	0.20	0.04	18.00	20.10			●			0.06-0.18
DGN 3102MF	3.10	0.20	0.04	18.00	20.10	●	●	●	●	●	0.06-0.18
DGN 4003MF	4.00	0.30	0.04	- ⁽³⁾	18.80	●				●	0.08-0.20

• For cutting speed recommendations and user guide, see pages 484-492

⁽¹⁾ Cutting width tolerance (+/-)⁽²⁾ Cutting depth maximum⁽³⁾ No depth limit

For tools, see pages: C#-HELIR/L (249) • C#-HFIR/L-MC (555) • CR HFIR-M (557) • DGFH (252) • DGFH-JHP (253) • DGFHR/L-BC-JHP (427) • DGPAD-JHP (437) • DGPAD-XL-JHP (437) • DGTR/L (433) • DGTR/L-B-D-JHP-SL (430) • DGTR/L-B-D-JHP-SL-MC (431) • HELIR/L (250) • HFAER/L-4 (551) • HFAIR/L-4 (554) • HFAIR/L-DG (555) • HFFR/L-T (550) • HFHR/L-4T (548) • HFIR/L-MC (556) • HFPAD-4 (549) • HGPAD (251) • HGPAD-JHP (251) • IM-HFIR-MC (556)

DO GRIP
TWISTED 2-SIDED**DGN-Z**

Double-Sided Inserts for Parting Tubes, Thin-Walled and Small Parts

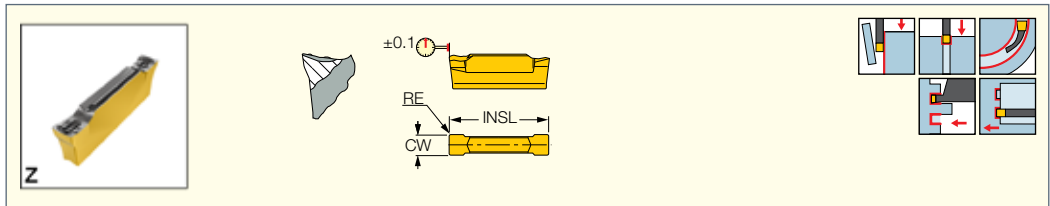

Designation	Dimensions						Tough ↔ Hard				Recommended Machining Data f groove (mm/rev)
	CW	CDX ⁽¹⁾	CWTOL ⁽²⁾	RE	RETOL ⁽³⁾	INSL	IC1030	IC1010	IC808	IC908	
DGN 2002Z	2.00	18.00	0.03	0.20	0.020	20.90	●	●	●	●	0.03-0.12
DGN 3002Z	3.00	18.00	0.03	0.20	0.020	20.90			●	●	0.03-0.16

• For cutting speed recommendations and user guide, see pages 484-492

⁽¹⁾ Cutting depth maximum⁽²⁾ Cutting width tolerance (+/-)⁽³⁾ Corner radius tolerance (+/-)

For tools, see pages: D/HGAD RE/LE-JHP (437) • DGAD-B-D (436) • DGAD/HGAD (436) • DGFH (252) • DGFH-JHP (253) • DGFHL-26B-TR-D (428) • DGFHR/L (426) • DGFHR/L-B-D..(R/L) (428) • DGFHR/L-BC-JHP (427) • DGFS (427) • DGPAD-JHP (437) • DGPAD-XL-JHP (437) • DGTR/L (433) • DGTR/L-B-D-JHP-SL (430) • DGTR/L-B-D-JHP-SL-MC (431) • DGTR/L-B-D-SH (429) • DGTR/L-B/BC-D (432)

DGR-Z/ZS

Double-Sided Inserts with Very Positive Rake for Parting Tubes and Thin-Walled and Small Parts

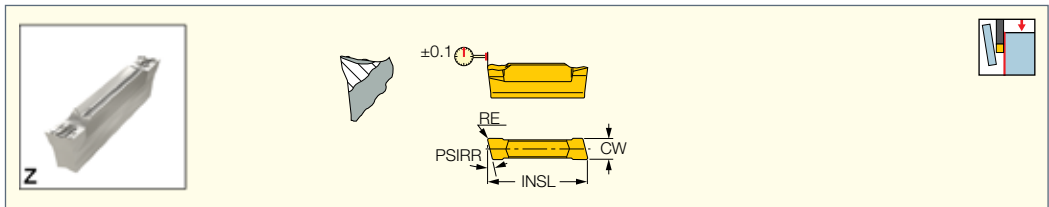

Designation	Dimensions						IC908	Recommended Machining Data f groove (mm/rev)
	CW	RE	INSL	CDX ⁽²⁾	PSIRR			
DGR 2000ZS-15D ⁽¹⁾	2.00	0.02	20.40	18.00	15.0	●	0.03-0.07	
DGR 2000ZS-6D ⁽¹⁾	2.00	0.02	20.40	18.00	6.0	●	0.03-0.08	
DGR 2002Z-15D	2.00	0.20	20.40	18.00	15.0	●	0.03-0.10	
DGR 2002Z-6D	2.00	0.20	20.90	18.00	6.0	●	0.03-0.10	
DGR 3000ZS-15D ⁽¹⁾	3.00	0.02	20.40	18.00	15.0	●	0.03-0.10	
DGR 3000ZS-6D ⁽¹⁾	3.00	0.02	20.40	18.00	6.0	●	0.03-0.12	
DGR 3002Z-6D	3.00	0.20	20.90	18.00	6.0	●	0.03-0.14	

• For cutting speed recommendations and user guide, see pages 484-492

⁽¹⁾ Sharp corners

⁽²⁾ Cutting depth maximum

For tools, see pages: D/HGAD RE/LE-JHP (437) • DGAD-B-D (436) • DGAD/HGAD (436) • DGFH (252) • DGFH-JHP (253) • DGFHL-26B-TR-D (428) • DGFHR/L (426) • DGFHR/L-B-D..(R/L) (428) • DGFHR/L-BC-JHP (427) • DGFS (427) • DGPAD-JHP (437) • DGPAD-XL-JHP (437) • DGTR/L (433) • DGTR/L-B-D-JHP-SL (430) • DGTR/L-B-D-JHP-SL-MC (431) • DGTR/L-B-D-SH (429) • DGTR/L-B/BC-D (432)

DGN-UT/UA

Double-Sided Inserts for Parting and Grooving Cr-Ni Alloys, Low Carbon Steel and Ductile Materials at Low Feeds

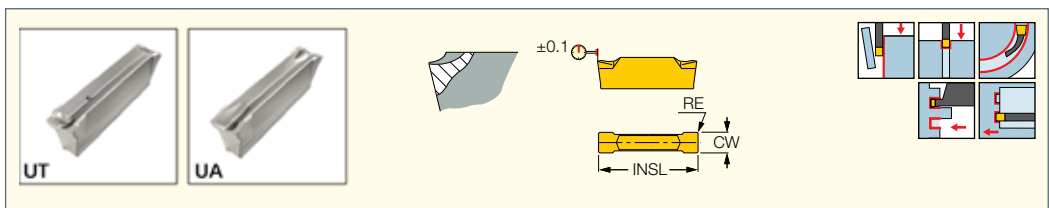

Designation	Dimensions						Tough ↔ Hard							Recommended Machining Data f groove (mm/rev)
	CW	CWTOL ⁽¹⁾	RE	RETOL ⁽²⁾	CDX ⁽³⁾	INSL	IC328	IC1028	IC354	IC350	IC308	IC908	IC20	
DGN 2202UA	2.20	0.03	0.20	0.020	18.00	19.90	●	●	●	●	●	●	●	0.04-0.13
DGN 2202UT	2.20	0.03	0.20	0.020	18.00	19.60	●	●	●	●	●	●	●	0.03-0.11
DGN 3003UA	3.00	0.03	0.25	0.020	18.00	20.50	●	●	●	●	●	●	●	0.04-0.15
DGN 3003UT	3.00	0.03	0.25	0.020	18.00	20.50	●	●	●	●	●	●	●	0.04-0.13
DGN 4003UA	4.00	0.04	0.30	0.020	- ⁽⁴⁾	19.40	●	●	●	●	●	●	●	0.05-0.16
DGN 4003UT	4.00	0.04	0.30	0.020	- ⁽⁴⁾	19.30	●	●	●	●	●	●	●	0.04-0.15
DGN 5003UT	5.00	0.04	0.30	0.020	- ⁽⁴⁾	19.00	●	●	●	●	●	●	●	0.05-0.18
DGN 6008UT	6.00	0.04	0.80	0.050	- ⁽⁴⁾	19.10	●	●	●	●	●	●	●	0.06-0.20

• For cutting speed recommendations and user guide, see pages 484-492

⁽¹⁾ Cutting width tolerance (+/-)

⁽²⁾ Corner radius tolerance (+/-)

⁽³⁾ Cutting depth maximum

⁽⁴⁾ No depth limit

For tools, see pages: C#-HELIR/L (249) • D/HGAD RE/LE-JHP (437) • DGAD-B-D (436) • DGAD/HGAD (436) • DGFH (252) • DGFH-JHP (253) • DGFHL-26B-TR-D (428) • DGFHR/L (426) • DGFHR/L-B-D..(R/L) (428) • DGFHR/L-BC-JHP (427) • DGFS (427) • DGPAD-JHP (437) • DGPAD-XL-JHP (437) • DGTR/L (433) • DGTR/L-B-D-JHP-SL (430) • DGTR/L-B-D-JHP-SL-MC (431) • DGTR/L-B-D-SH (429) • DGTR/L-B/BC-D (432) • DGTR/L-BC-T (433) • HELIR/L (250) • HGPAD (251) • HGPAD-JHP (251)



DGN-P

Double-Sided Inserts for Parting and Grooving Soft Materials, Thin and Miniature Parts

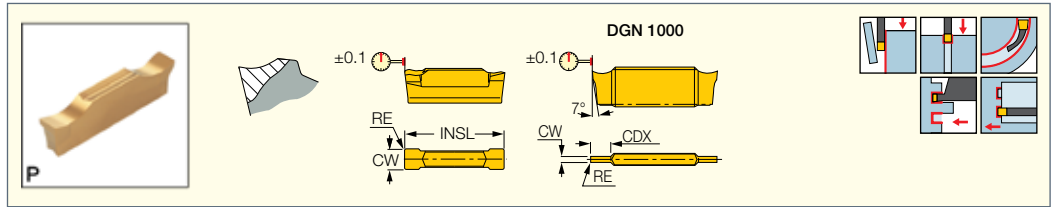

Designation	Dimensions						IC508	Recommended Machining Data f groove (mm/rev)
	CW	RE	CWTOL ⁽¹⁾	RETOL ⁽²⁾	INSL	CDX		
DGN 1000P	1.00	0.05	0.02	0.020	20.00	3.00	●	0.02-0.05
DGN 1500P	1.50	0.05	0.02	0.020	20.00	18.00	●	0.02-0.07
DGN 2000P	2.00	0.05	0.02	0.020	20.00	18.00	●	0.02-0.08
DGN 3000P	3.00	0.05	0.02	0.020	20.00	18.00	●	0.02-0.10

• For cutting speed recommendations and user guide, see pages 484-492

⁽¹⁾ Cutting width tolerance (+/-)

⁽²⁾ Corner radius tolerance (+/-)

For tools, see pages: D/HGAD RE/LE-JHP (437) • DGAD-B-D (436) • DGAD/HGAD (436) • DGFH (252) • DGFH-JHP (253) • DGFHL-26B-TR-D (428) • DGFHR/L (426) • DGFHR/L-B-D..(R/L) (428) • DGFHR/L-BC-JHP (427) • DGFS (427) • DGPAD-JHP (437) • DGPAD-XL-JHP (437) • DGTR/L (433) • DGTR/L-B-D-JHP-SL (430) • DGTR/L-B-D-JHP-SL-MC (431) • DGTR/L-B-D-SH (429) • DGTR/L-B-D-TR (434) • DGTR/L-B-T-SH (432) • DGTR/L-B/BC-D (432)



DGR-P

Double-Sided Inserts for Parting Soft Materials, Thin and Miniature Parts

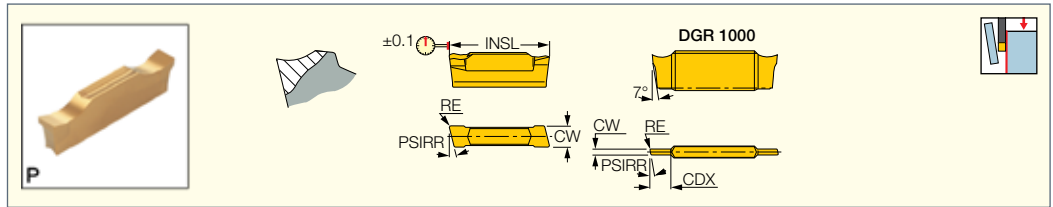

Designation	Dimensions						IC508	Recommended Machining Data f groove (mm/rev)
	CW	RE	INSL	CDX ⁽¹⁾	PSIRL	PSIRR		
DGR 1000P-15D	1.00	0.05	20.60	2.90	-	15.0	●	0.02-0.03
DGR 1000P-6D	1.00	0.05	20.60	2.90	-	6.0	●	0.02-0.04
DGR 1500P-15D	1.50	0.05	20.60	-	-	15.0	●	0.02-0.04
DGR 1500P-6D	1.50	0.05	20.60	-	-	6.0	●	0.02-0.05
DGR 2000P-15D	2.00	0.05	20.60	-	-	15.0	●	0.02-0.05
DGR 2000P-6D	2.00	0.05	20.60	-	-	6.0	●	0.02-0.07

• For cutting speed recommendations and user guide, see pages 484-492

⁽¹⁾ Cutting depth maximum

For tools, see pages: D/HGAD RE/LE-JHP (437) • DGAD-B-D (436) • DGAD/HGAD (436) • DGFH (252) • DGFH-JHP (253) • DGFHL-26B-TR-D (428) • DGFHR/L (426) • DGFHR/L-B-D..(R/L) (428) • DGFS (427) • DGPAD-JHP (437) • DGTR/L (433) • DGTR/L-B-D-JHP-SL (430) • DGTR/L-B-D-JHP-SL-MC (431) • DGTR/L-B-D-SH (429) • DGTR/L-B-D-TR (434) • DGTR/L-B-T-SH (432) • DGTR/L-B/BC-D (432)



DGN-WP

Double-Sided Parting and Grooving Inserts with a Wiper Design for High Flatness and Surface Finish

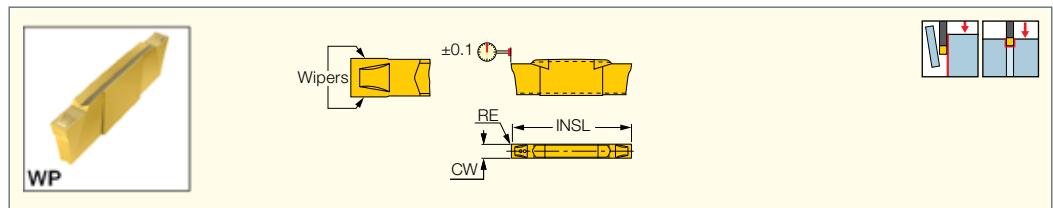

Designation	Dimensions						IC328	Recommended Machining Data f groove (mm/rev)
	CW	RE	CWTOL ⁽¹⁾	RETOL ⁽²⁾	CDX ⁽³⁾	INSL		
DGN 1900WP	1.90	0.05	0.02	0.020	6.00	19.70	●	0.04-0.12
DGN 2400WP	2.39	0.05	0.02	0.020	6.00	20.40	●	0.05-0.14

• For cutting speed recommendations and user guide, see pages 484-492

⁽¹⁾ Cutting width tolerance (+/-)

⁽²⁾ Corner radius tolerance (+/-)

⁽³⁾ Cutting depth maximum

For tools, see pages: D/HGAD RE/LE-JHP (437) • DGAD-B-D (436) • DGAD/HGAD (436) • DGFH (252) • DGFH-JHP (253) • DGFHL-26B-TR-D (428) • DGFHR/L (426) • DGFHR/L-B-D..(R/L) (428) • DGFS (427) • DGPAD-JHP (437) • DGTR/L (433) • DGTR/L-B-D-JHP-SL (430) • DGTR/L-B-D-JHP-SL-MC (431) • DGTR/L-B-D-SH (429) • DGTR/L-B/BC-D (432)

DGR-WP

Double-Sided Parting Inserts with a Wiper Design for High Flatness and Surface Finish

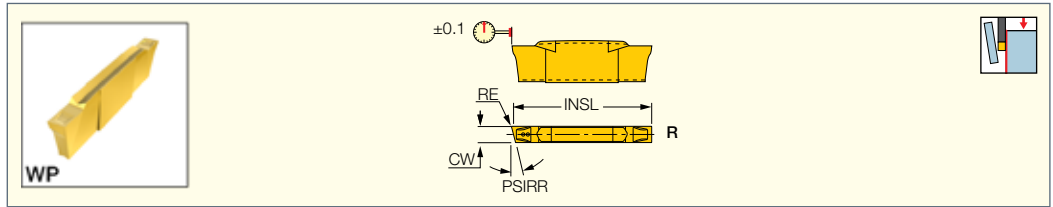

Designation	Dimensions						IC328	Recommended Machining Data
	CW	RE	CDX ⁽¹⁾	INSL	PSIRR	f groove (mm/rev)		
DGR 1900WP-12D	1.90	0.05	6.00	19.70	12.0	●	0.04-0.10	
DGR 1900WP-5D	1.90	0.05	6.00	19.70	5.0	●	0.04-0.10	
DGR 2400WP-12D	2.39	0.05	6.00	20.40	12.0	●	0.04-0.10	
DGR 2400WP-5D	2.39	0.05	6.00	20.40	5.0	●	0.04-0.12	

• For cutting speed recommendations and user guide, see pages 484-492

⁽¹⁾ Cutting depth maximum

For tools, see pages: D/HGAD RE/LE-JHP (437) • DGAD-B-D (436) • DGAD/HGAD (436) • DGFH (252) • DGFH-JHP (253) • DGFHR/L (426) • DGFHR/L-B-D..(R/L) (428) • DGFS (427) • DGPAD-JHP (437) • DGTR/L (433) • DGTR/L-B-D-JHP-SL (430) • DGTR/L-B-D-JHP-SL-MC (431) • DGTR/L-B-D-SH (429) • DGTR/L-B/BC-D (432)

HGN-C

Parting and Grooving Inserts for Parting Bars, Hard Materials and Tough Applications

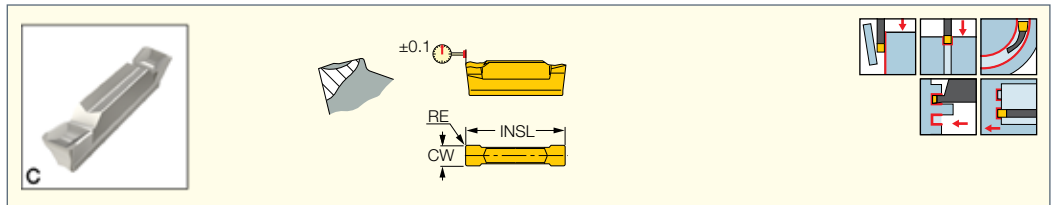

Designation	Dimensions				Tough ↔ Hard					Recommended Machining Data
	CW	RE	CWTOL ⁽¹⁾	INSL	IC328	IC830	IC354	IC308	IC908	f groove (mm/rev)
HGN 3003C	3.00	0.30	0.05	15.80	●	●	●	●	●	0.08-0.20

• No depth limit • For cutting speed recommendations and user guide, see pages 484-492

⁽¹⁾ Cutting width tolerance (+/-)

For tools, see pages: C#-HELIR/L (249) • D/HGAD RE/LE-JHP (437) • DGAD/HGAD (436) • HELIR/L (250) • HFPAD-3 (549) • HGAIR/L-3 (554) • HGFH (251) • HGHR/L-3 (547) • HGPAD (251) • HGPAD-JHP (251)

HGR/L-C

Inserts for Parting Bars, Hard Materials and Tough Applications

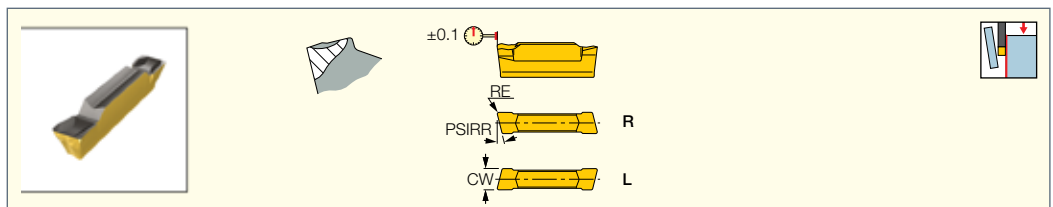

Designation	Dimensions						Tough ↔ Hard		Recommended Machining Data
	CW	RE	INSL	PSIRL	PSIRR	IC328	IC830	f groove (mm/rev)	
HGL 3003C-6D	3.00	0.30	15.60	6.0	-	●	●	0.06-0.16	
HGR 3003C-6D	3.00	0.30	15.60	-	6.0	●	●	0.06-0.16	

• No depth limit • For cutting speed recommendations and user guide, see pages 484-492

For tools, see pages: D/HGAD RE/LE-JHP (437) • DGAD/HGAD (436) • HELIR/L (250) • HGFH (251)

DO-GRIP
TWISTED 2-SIDED**HGN-J**

Inserts for Parting and Grooving Soft Materials, Parting Tubes, Small Diameters and Thin-Walled Parts

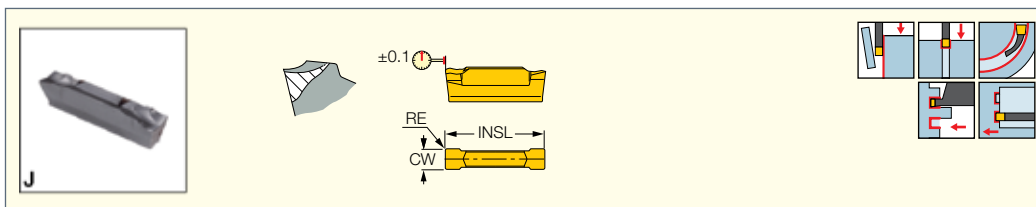

Designation	Dimensions					Tough ↔ Hard				Recommended Machining Data
	CW	RE	CWTOL ⁽¹⁾	RETOL ⁽²⁾	INSL	IC328	IC830	IC354	IC308	
HGN 3002J	3.00	0.20	0.05	0.030	16.10	●	●	●	●	0.04-0.15

• No depth limit • For cutting speed recommendations and user guide, see pages 484-492

⁽¹⁾ Cutting width tolerance (+/-)⁽²⁾ Corner radius tolerance (+/-)

For tools, see pages: C#-HELIR/L (249) • D/HGAD RE/LE-JHP (437) • DGAD/HGAD (436) • HELIR/L (250) • HFPAD-3 (549) • HGAIR/L-3 (554) • HGFH (251) • HGHR/L-3 (547) • HGPAD (251) • HGPAD-JHP (251)

DO-GRIP
TWISTED 2-SIDED**HGR/L-J/JS**

Double-Sided Inserts for Parting Soft Materials, Tubes, Small Diameters and Thin-Walled Parts

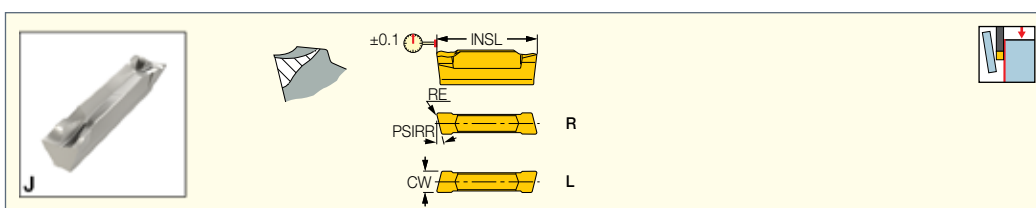

Designation	Dimensions					Tough ↔ Hard			Recommended Machining Data
	CW	RE	PSIRL	PSIRR	INSL	IC328	IC830	IC354	
HGL 3000JS-15D⁽¹⁾	3.00	0.02	15.0	-	15.20	●			0.03-0.07
HGL 3002J-6D	3.00	0.20	6.0	-	15.70	●			0.04-0.12
HGR 3000JS-15D⁽¹⁾	3.00	0.02	-	15.0	15.20	●			0.03-0.07
HGR 3002J-6D	3.00	0.20	-	6.0	15.70	●	●	●	0.04-0.12

• No depth limit • For cutting speed recommendations and user guide, see pages 484-492

⁽¹⁾ Sharp corners

For tools, see pages: D/HGAD RE/LE-JHP (437) • DGAD/HGAD (436) • HELIR/L (250) • HGFH (251)

DO-GRIP
TWISTED 2-SIDED**HGN-UT**

Double-Sided Inserts for Parting and Grooving Low Feeds on Cr-Ni Alloys and Low Carbon Steel

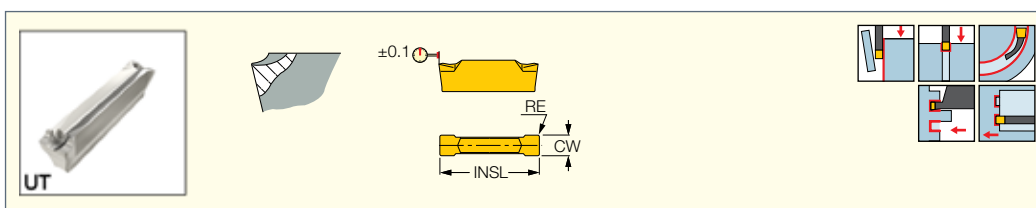

Designation	Dimensions					Tough ↔ Hard		Recommended Machining Data
	CW	RE	CWTOL ⁽¹⁾	RETOL ⁽²⁾	INSL	IC328	IC354	
HGN 3003UT	3.00	0.30	0.05	0.030	15.80	●	●	0.04-0.13

• No depth limit • For cutting speed recommendations and user guide, see pages 484-492

⁽¹⁾ Cutting width tolerance (+/-)⁽²⁾ Corner radius tolerance (+/-)

For tools, see pages: C#-HELIR/L (249) • D/HGAD RE/LE-JHP (437) • DGAD/HGAD (436) • HELIR/L (250) • HFPAD-3 (549) • HGAIR/L-3 (554) • HGFH (251) • HGHR/L-3 (547) • HGPAD (251) • HGPAD-JHP (251)

DOGRIPXL**DGN-C-XL**

Extra Long Parting and Grooving Inserts for Parting Bars Up to 65 mm Diameters, Hard Materials and Tough Applications

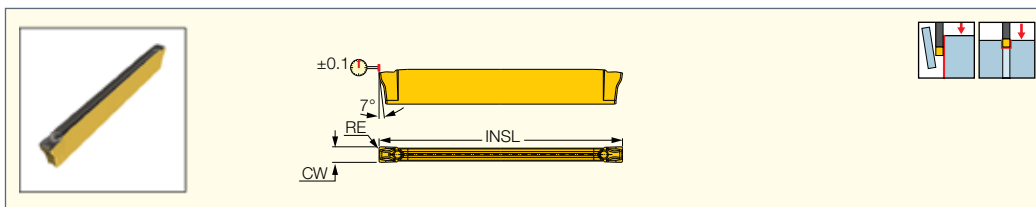

Designation	Dimensions						Tough ↔ Hard			Recommended Machining Data
	CW	RE	CWTOL ⁽¹⁾	RETOL ⁽²⁾	CDX	INSL	IC830	IC5400	IC808	
DGN 2002C-XL	2.05	0.20	0.04	0.03	30.00	32.00	●	●	●	f groove (mm/rev) 0.05-0.16
DGN 3002C-XL	3.00	0.20	0.04	0.03	32.50	35.00	●	●	●	0.07-0.20

• For cutting speed recommendations and user guide, see pages 484-492

⁽¹⁾ Cutting width tolerance (+/-)

⁽²⁾ Corner radius tolerance (+/-)

For tools, see pages: DGTR/L-XL (434)

DOGRIPXL**DGR/L-C-XL**

Extra Long Double-Sided Inserts for Parting Bars, Hard Materials and Tough Applications

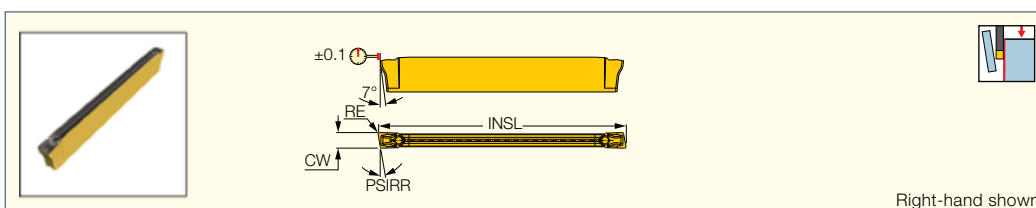

Designation	Dimensions						Tough ↔ Hard		Recommended Machining Data
	CW	RE	CDX ⁽¹⁾	PSIRL	PSIRR	INSL	IC830	IC808	
DGL 2002C-6D-XL	2.00	0.20	30.00	6.0	-	32.00	●	●	f groove (mm/rev) 0.05-0.12
DGR 2002C-6D-XL	2.00	0.20	30.00	-	6.0	32.00	●	●	0.05-0.12
DGL 3002C-6D-XL	3.00	0.20	32.50	6.0	-	35.00	●	●	0.08-0.18
DGR 3002C-6D-XL	3.00	0.20	32.50	-	6.0	35.00	●	●	0.08-0.18

• For cutting speed recommendations and user guide, see pages 484-492

⁽¹⁾ Cutting depth maximum

For tools, see pages: DGTR/L-XL (434)

DOGRIPXL**DGN-J-XL**

Extra Long Inserts for Parting and Grooving Soft Materials, Parting Tubes, Small Diameters and Thin-Walled Parts

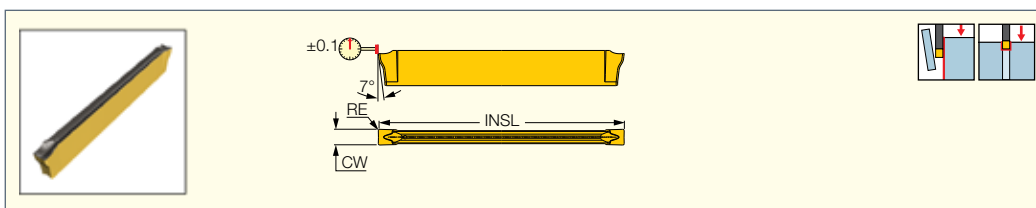

Designation	Dimensions						Tough ↔ Hard			Recommended Machining Data
	CW	RE	CWTOL ⁽¹⁾	RETOL ⁽²⁾	CDX	INSL	IC830	IC5400	IC808	
DGN 2002J-XL	2.05	0.20	0.04	0.03	30.00	32.00	●	●	●	f groove (mm/rev) 0.04-0.14
DGN 3002J-XL	3.00	0.20	0.04	0.03	32.50	35.00	●	●	●	0.04-0.16

• For cutting speed recommendations and user guide, see pages 484-492

⁽¹⁾ Cutting width tolerance (+/-)

⁽²⁾ Corner radius tolerance (+/-)

For tools, see pages: DGTR/L-XL (434)

DOGRIPXL**DGR/L-J-XL**

Extra Long Double-Sided Inserts for Parting Soft Materials, Tubes, Small Diameters and Thin-Walled Parts

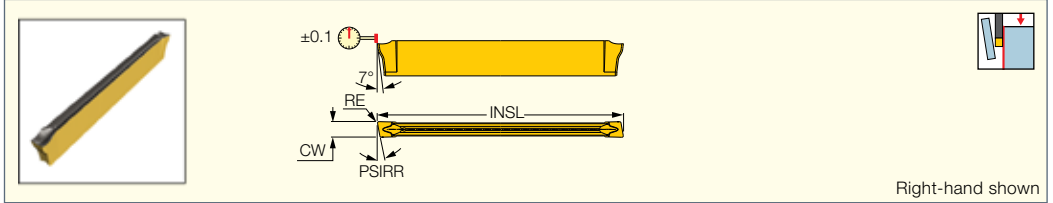

Right-hand shown

Designation	Dimensions						Tough ↔ Hard		Recommended Machining Data
	CW	RE	CDX ⁽¹⁾	PSIRL	PSIRR	INSL	IC880	IC808	
DGL 2002J-6D-XL	2.00	0.20	30.00	6.0	-	32.00	●	●	f groove (mm/rev) 0.04-0.10
DGR 2002J-6D-XL	2.00	0.20	30.00	-	6.0	32.00	●	●	0.04-0.10
DGL 3002J-6D-XL	3.00	0.20	32.50	6.0	-	35.00	●	●	0.04-0.14
DGR 3002J-6D-XL	3.00	0.20	32.50	-	6.0	35.00	●	●	0.04-0.14

• For cutting speed recommendations and user guide, see pages 484-492

⁽¹⁾ Cutting depth maximum

For tools, see pages: DGTR/L-XL (434)

ISCARPARTING**JETCUT****BGTR/L-B-JHP**

Integral Shank Parting and Grooving Tools with Coolant Channels Carrying Narrow Inserts for Parting up to 20 mm Bars

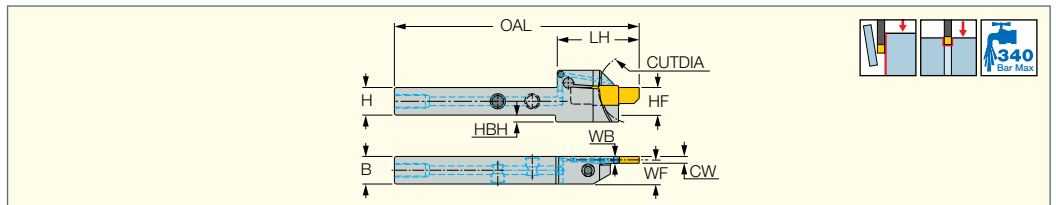

Designation	CWN ⁽¹⁾	CWX ⁽²⁾	H	HF	B	WB	OAL	LH	CUTDIA ⁽³⁾	WF	HBH
BGTR/L 16B-D20-JHP	0.80	1.50	16.0	16.0	16.0	4.00	142.00	47.5	40.0	14.00	4.0
BGTR/L 20B-D20-JHP	0.80	1.50	20.0	20.0	20.0	4.00	142.00	47.5	40.0	18.00	-
BGTR/L 25B-D20-JHP	0.80	1.50	25.0	25.0	25.0	4.00	142.00	47.5	40.0	23.00	-

• For user guide, see pages 484-492

⁽¹⁾ Minimum cutting width

⁽²⁾ Maximum cutting width

⁽³⁾ The specified limit refers to the tool

For inserts, see pages: BGM N-J (448) • BGM R/L-J (449)

For holders, see pages: C#-ADE (673) • C#-ADES (674) • C#-ASHA (673) • C#-ASHA-HPMC (675) • C#-ASHR/L (672) • C#-ASHR/L-45 (673) • C#-ASHR/L-45-HPMC (675) • C#-ASHR/L-HPMC (675) • HSK A-WH-ASHR/L-1 (677) • HSK A63WH-ASHN-45 (676) • HSK A63WH-ASHR/L-2 (677) • HSK A63WH-ASHR/L-3 (677) • HSK A63WH-ASHR/L-45 (677)

Spare Parts

Designation				
BGTL 16B-D20-JHP	SR M5X16 DIN912	HW 3.0	SR 5/16UNF TL360	HW 5.0
BGTR 16B-D20-JHP	SR M5X16 DIN912	HW 3.0	SR 5/16UNF TL360	HW 4.0
BGTL 20B-D20-JHP	SR M5X16 DIN912	HW 3.0	PLG 1/8BSP TL360	HW 5.0
BGTR 20B-D20-JHP	SR M5X16 DIN912	HW 3.0	PLG 1/8BSP TL360	HW 5.0
BGTL 25B-D20-JHP	SR M5X16 DIN912	HW 3.0	PLG 1/8BSP TL360	HW 5.0
BGTR 25B-D20-JHP	SR M5X16 DIN912	HW 3.0	PLG 1/8BSP TL360	HW 5.0

ISCARPARTING**BGM N-J**

Narrow Material Cost Saving Inserts for Grooving and Parting up to 20 mm Bar Diameters

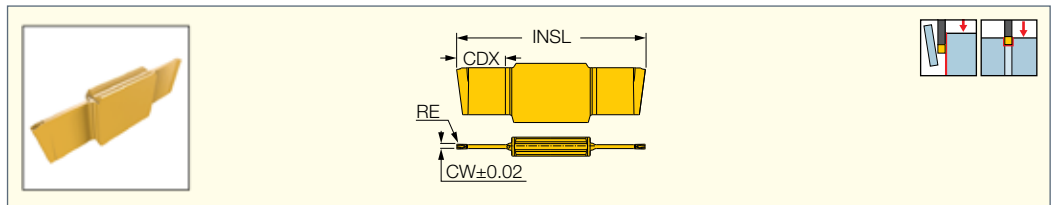

Designation	Dimensions						IC1008	Recommended Machining Data
	CW	CWTOL ⁽¹⁾	RE	RETOL ⁽²⁾	CDX	INSL		
BGM N0801J	0.80	0.02	0.10	0.020	10.00	38.70	●	f groove (mm/rev) 0.02-0.05
BGM N1001J	1.00	0.02	0.10	0.020	10.00	38.70	●	0.02-0.08
BGM N1201J	1.20	0.02	0.10	0.020	10.00	38.70	●	0.03-0.10
BGM N1501J	1.50	0.02	0.10	0.020	10.00	38.70	●	0.05-0.12

• For cutting speed recommendations and user guide, see pages 484-492

⁽¹⁾ Cutting width tolerance (+/-)

⁽²⁾ Corner radius tolerance (+/-)

For tools, see pages: BGTR/L-B-JHP (448)

ISCARPARTING

BGM R/L-J

Narrow Material Cost Saving
Inserts for Parting up to
20 mm Bar Diameters

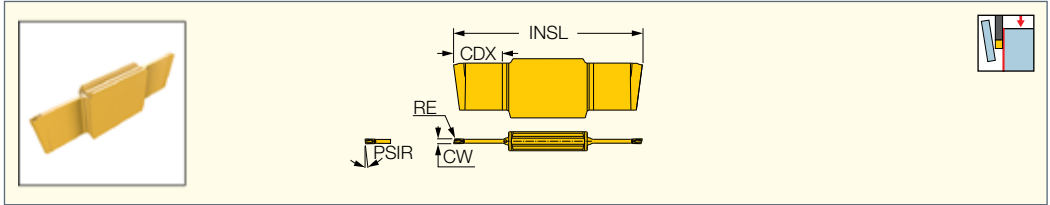

Designation	Dimensions					IC1008	Recommended Machining Data
	CW	RE	INSL	CDX	PSIR		
BGM R/L1001J-15D	1.00	0.10	38.70	10.00	15.0	•	f groove (mm/rev) 0.02-0.06
BGM R/L1001J-6D	1.00	0.10	38.70	10.00	6.0	•	0.02-0.08

• For cutting speed recommendations and user guide, see pages 484-492
For tools, see pages: BGTR/L-B-JHP (448)

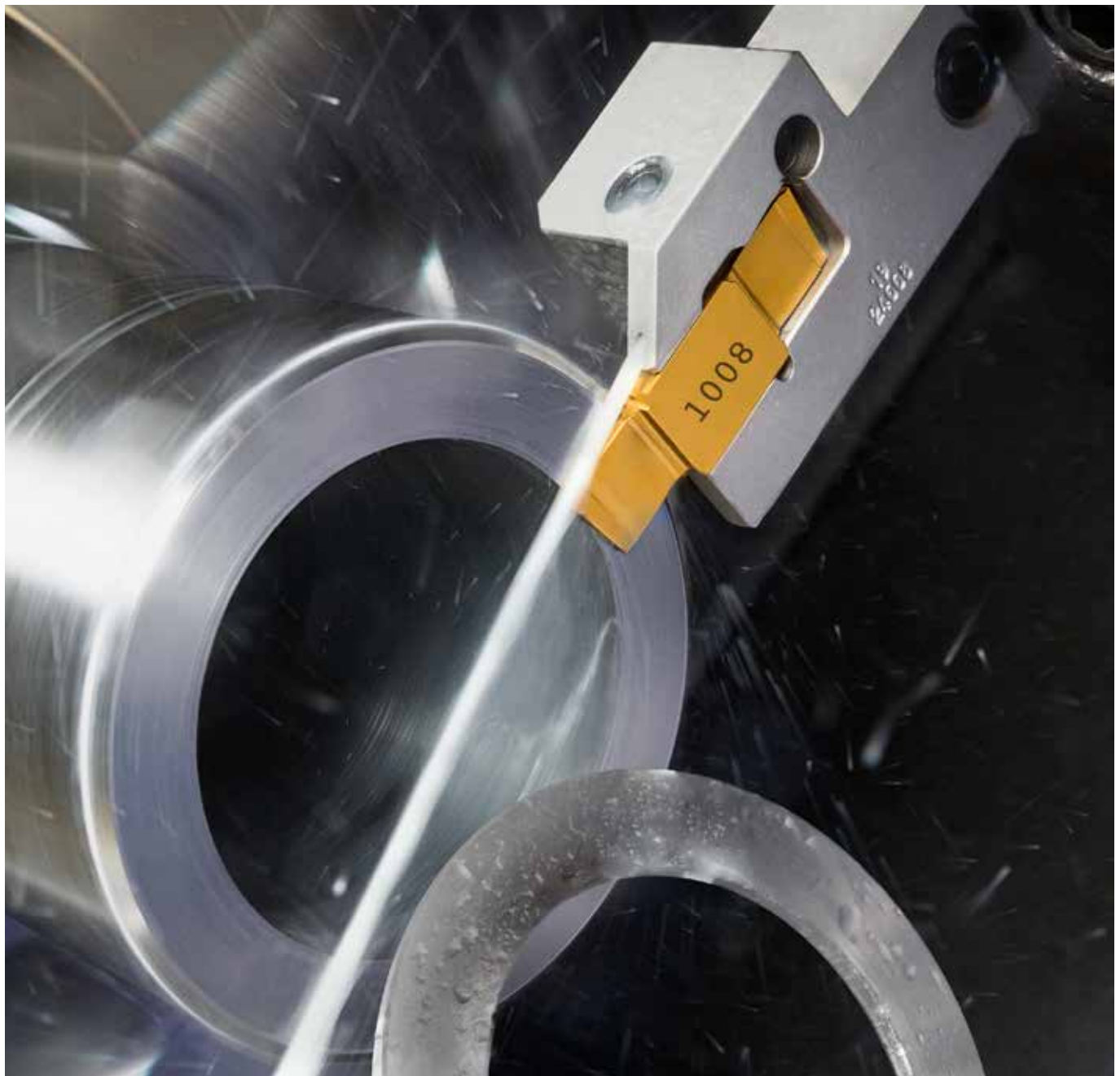

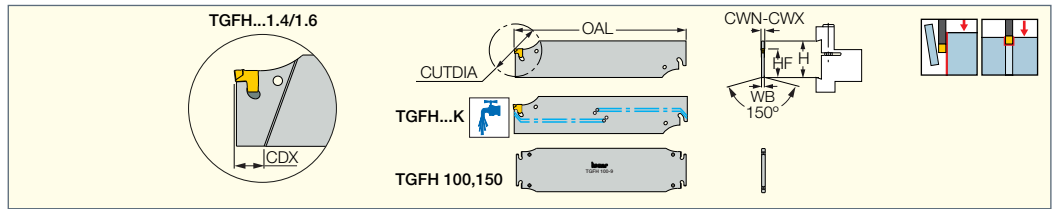
TANG-GRIP
PARTING LINE**SUMO-GRIP**
HEAVY DUTY LINE**TGFH/R/L**Blades with a Tangentially
Oriented Pocket Carrying
TANG-GRIP Single-Ended
Inserts for Parting and Grooving

Designation	H	CWN ⁽²⁾	CWX ⁽³⁾	WB	OAL	CDX	HF	CUTDIA	CSP ⁽⁴⁾	Insert		
TGFH 19-1.4	19.0	1.40	1.40	1.05 ⁽⁵⁾	86.00	9.60	15.7	30.0	0	TAG 1.4	ETG 1.4/1.6*	
TGFH 19-1.6	19.0	1.60	1.60	1.30 ⁽⁶⁾	86.00	11.00	15.7	32.0	0	TAG 1.6	ETG 1.4/1.6*	
TGFH 19-2	19.0	1.80	2.40	1.65	86.00	-	15.7	38.0	0	TAG 2	ETG 2*	
TGFH 26-1.4	26.0	1.40	1.40	1.05 ⁽⁵⁾	110.00	8.30	21.4	29.0	0	TAG 1.4	ETG 1.4/1.6*	
TGFH 26-1.6	26.0	1.60	1.60	1.30 ⁽⁶⁾	110.00	10.00	21.4	35.0	0	TAG 1.6	ETG 1.4/1.6*	
TGFH 26-2	26.0	1.80	2.40	1.65	110.00	-	21.4	50.0	0	TAG 2	ETG 2*	
TGFH 26-3	26.0	2.80	3.50	2.50	110.00	-	21.4	75.0	0	TAG 3	ETG 3-4*	
TGFH 26K-3 ⁽¹⁾	26.0	2.80	3.50	2.50	110.00	-	21.4	75.0	1	TAG 3	ETG 3-4-SH*	SGC 340
TGFH 26-4	26.0	3.70	4.50	3.40	110.00	-	21.4	80.0	0	TAG 4	ETG 3-4*	
TGFH 26-5	26.0	4.70	5.50	4.00	150.00	-	21.4	80.0	0	TAG 5	ETG 5-7*	
TGFH 32-1.4	32.0	1.40	1.40	1.05 ⁽⁵⁾	150.00	7.10	24.8	29.0	0	TAG 1.4	ETG 1.4/1.6*	
TGFH 32-1.6	32.0	1.60	1.60	1.30 ⁽⁶⁾	150.00	10.00	24.8	38.0	0	TAG 1.6	ETG 1.4/1.6*	
TGFH 32-2	32.0	1.80	2.40	1.65 ⁽⁵⁾	150.00	-	24.8	50.0	0	TAG 2	ETG 2*	
TGFH 32-3	32.0	2.80	3.50	2.50	150.00	-	24.8	100.0	0	TAG 3	ETG 3-4*	
TGFH 32K-3 ⁽¹⁾	32.0	2.80	3.50	2.50	150.00	-	24.8	100.0	1	TAG 3	ETG 3-4-SH*	SGC 340
TGFH 32-4	32.0	3.70	4.50	3.40	150.00	-	24.8	100.0	0	TAG 4	ETG 3-4*	
TGFH 32K-4 ⁽¹⁾	32.0	3.70	4.50	3.40	150.00	-	24.8	100.0	1	TAG 4	ETG 3-4-SH*	SGC 340
TGFH 32-5	32.0	4.70	5.50	4.00	150.00	-	24.8	120.0	0	TAG 5	ETG 5-7*	
TGFH 32-6	32.0	5.70	6.50	5.20	150.00	-	24.8	120.0	0	TAG 6	ETG 5-7*	
TGFH 32-7	32.0	6.80	7.50	6.00	148.00	-	24.8	120.0	0	TAG 7	ETG 5-7*	
TGFH 45-3	45.0	2.80	3.50	2.50	225.00	-	38.1	160.0	0	TAG 3	ETG 3-4*	
TGFH 45-4	45.0	3.70	4.50	3.40	225.00	-	38.1	160.0	0	TAG 4	ETG 3-4*	
TGFH 45-5	45.0	4.70	5.50	4.00	225.00	-	38.1	160.0	0	TAG 5	ETG 5-7*	
TGFH 45-6	45.0	5.70	6.50	5.20	225.00	-	38.1	160.0	0	TAG 6	ETG 5-7*	
TGFH 45-7	45.0	6.80	7.50	6.00	225.00	-	38.1	160.0	0	TAG 7	ETG 5-7*	
TGFH 52-7	52.6	6.80	7.50	6.00	190.00	-	45.2	190.0	0	TAG 7	ETG 5-7*	
TGFH 53-7	52.6	6.80	7.50	6.00	260.00	-	45.2	220.0	0	TAG 7	ETG 5-7*	
TGFH 52K-8 ⁽¹⁾	52.6	7.70	8.50	7.20	190.00	-	45.2	190.0	1	TAG 8	ETG 8-12*	
TGFH 53K-8 ⁽¹⁾	52.6	7.70	8.50	7.20	260.00	-	45.2	215.0	1	TAG 8	ETG 8-12*	
TGFH 52K-9 ⁽¹⁾	52.6	8.70	10.00	8.20	190.00	-	45.2	190.0	1	TAG 9	ETG 8-12*	
TGFH 53K-9 ⁽¹⁾	52.6	8.70	10.00	8.20	260.00	-	45.2	215.0	1	TAG 9	ETG 8-12*	
TGFHR/L 53K-12 ⁽¹⁾	52.6	11.70	12.70	10.00	260.00	-	45.2	215.0	1	TAG 12	ETG 8-12*	
TGFH 100-9	100.0	8.70	10.00	8.20	460.00	-	92.5	450.0	0	TAG 9	ETG 8-12*	
TGFH 100-12	100.0	11.70	12.70	10.00	460.00	-	92.5	450.0	0	TAG 12	ETG 8-12*	
TGFH 150-12	150.0	11.70	12.70	10.00	610.00	-	142.5	600.0	0	TAG 12	ETG 8-12*	

* For user guide, see pages 484-492

⁽¹⁾ With coolant holes, the recommended coolant pressure is 10 bar min.; cooling tube SGCU 341 should be ordered separately

⁽²⁾ Minimum cutting width

⁽³⁾ Maximum cutting width

⁽⁴⁾ 0 - Without coolant supply, 1 - With coolant supply

⁽⁵⁾ Thickness beyond the D.O.C. area is 2.50 mm

⁽⁶⁾ Thickness beyond the D.O.C. area is 1.60 mm

* Optional, should be ordered separately

For inserts, see pages: TAG N-A (467) • TAG N-C/W/M (463) • TAG N-HF (463) • TAG N-J/JS/JT (465) • TAG N-LF (466) • TAG N-MF (464) • TAG N-UT (467) • TAG R/L-C (464) • TAG R/L-J/JS (466) • TAGB/TAGBA (319)

For holders, see pages: C#-TBK-R/L (591) • HSK A-WH-TBK-R/L (598) • SGTBF (587) • SGTBK (587) • SGTBR/L (587) • SGTBU/SGTBN (586) • UBHCR/L (587)

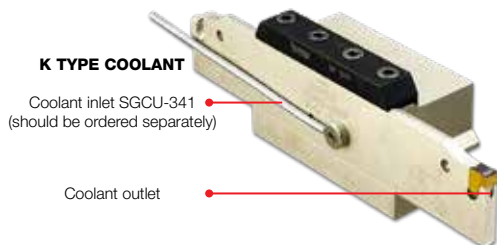

TGFH-JHP

Parting and Grooving Blades with Channels for Low and High Pressure Coolant Carrying TANG-GRIP Inserts

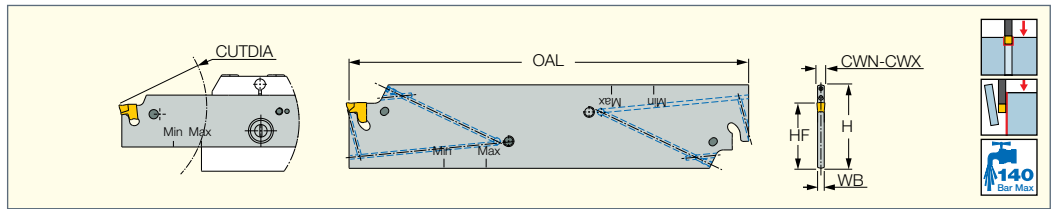

Designation	H	CWN ⁽²⁾	CWX ⁽³⁾	WB	OAL	HF	CUTDIA	Insert		
TGFH 26C-3-JHP	26.0	2.80	3.50	2.50	140.00	21.4	75.0	TAG 3	SGC 340	ETG 3-4-SH*
TGFH 32C-3-JHP	32.0	2.80	3.50	2.50	150.00	24.8	90.0	TAG 3	SGC 340	ETG 3-4-SH*
TGFH 26C-4-JHP	26.0	3.70	4.50	3.40	140.00	21.4	75.0	TAG 4	SGC 340	ETG 3-4-SH*
TGFH 32C-4-JHP	32.0	3.70	4.50	3.40	150.00	24.8	90.0	TAG 4	SGC 340	ETG 3-4-SH*
TGFH 32C-5-JHP	32.0	4.70	5.50	4.00	160.00	24.8	120.0	TAG 5	SGC 340	ETG 5-7*
TGFH 32C-6-JHP ⁽¹⁾	32.0	5.70	6.50	5.20	160.00	24.8	120.0	TAG 6	SGC 340	ETG 5-7*

• For user guide and accessories, see pages 484-492

⁽¹⁾ Only an upper channel

⁽²⁾ Minimum cutting width

⁽³⁾ Maximum cutting width

* Optional, should be ordered separately

For inserts, see pages: TAG N-A (467) • TAG N-C/W/M (463) • TAG N-HF (463) • TAG N-J/JS/JT (465) • TAG N-LF (466) • TAG N-MF (464) • TAG N-UT (467) • TAG R/L-C (464) • TAG R/L-J/JS (466) • TAGB/TAGBA (319)

For holders, see pages: TGTBU-JHP (454)

TGFH-S

Parting and Grooving Single-Sided Blades for TANG-GRIP Inserts

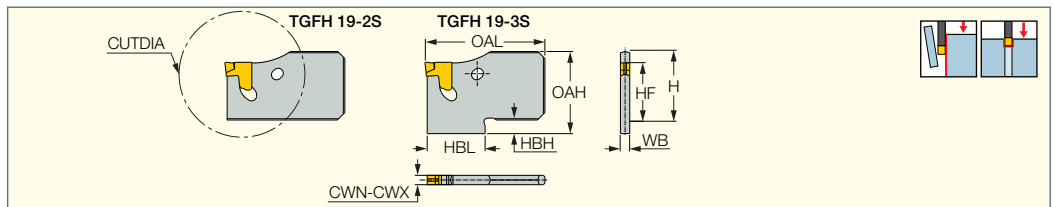

Designation	H	CWN ⁽¹⁾	CWX ⁽²⁾	WB	OAL	HF	OAH	HBH	HBL	CDX ⁽³⁾	CUTDIA	
TGFH 19-2S	19.0	1.80	2.40	1.65	32.00	15.7	19.0	-	-	12.00	36.0	ETG 2*
TGFH 19-3S	19.0	2.80	3.50	2.50	32.00	15.7	22.0	3.0	15.5	16.00	40.0	ETG 3-4-SH*

• For Dmax and Tmax drawing, see SGBHR/L holder

⁽¹⁾ Minimum cutting width

⁽²⁾ Maximum cutting width

⁽³⁾ Cutting depth maximum

* Optional, should be ordered separately

For inserts, see pages: TAG N-A (467) • TAG N-C/W/M (463) • TAG N-HF (463) • TAG N-J/JS/JT (465) • TAG N-LF (466) • TAG N-MF (464) • TAG N-UT (467) • TAG R/L-C (464) • TAG R/L-J/JS (466)

SGBHR/L

Tool Blocks for SELF-GRIP Single-Sided Blades

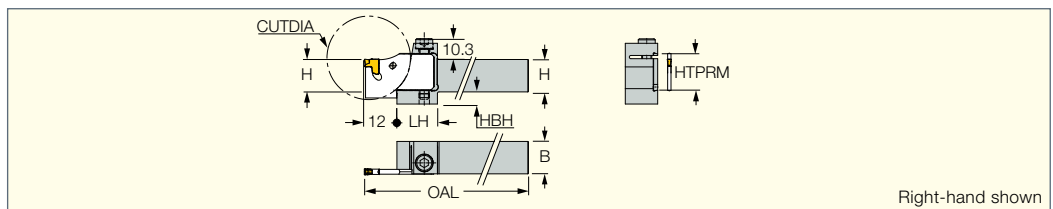

Designation	H	B	HBH	OAL	HTPRM	LH	CDX ⁽¹⁾	CUTDIA		
SGBHR/L 1010	10.0	10.0	10.0	154.00	19.0	20.0	16.00	40.0	SR M5X25 DIN912	HW 4.0
SGBHR 1212	12.0	12.0	8.0	154.00	19.0	20.0	16.00	40.0	SR M5X25 DIN912	HW 4.0
SGBHR 1414	14.0	14.0	6.0	154.00	19.0	20.0	16.00	40.0	SR M5X25 DIN912	HW 4.0
SGBHR/L 1616	16.0	16.0	6.0	154.00	19.0	20.0	16.00	40.0	SR M5X25 DIN912	HW 4.0
SGBHR/L 2020	20.0	20.0	2.0	154.00	19.0	20.0	16.00	40.0	SR M5X25 DIN912	HW 4.0
SGBHR/L 2525	25.0	25.0	-	154.00	19.0	20.0	16.00	40.0	SR M5X25 DIN912	HW 4.0

• For Dmax and Tmax dimensions, see TGFH-S adapters

⁽¹⁾ Cutting depth maximum

For tools, see pages: TGFH-S (451)



TGFHR/L

Single- and Double-Ended Parting and Grooving Reinforced Blades Carrying TANG-GRIP Tangentially Clamped Inserts

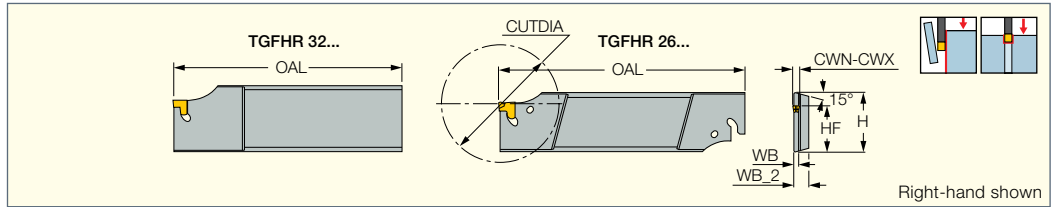

Designation	H	CWN ⁽¹⁾	CWX ⁽²⁾	WB	WB_2	OAL	HF	CUTDIA	
TGFHL 26T16-2	26.0	1.80	2.40	1.65	7.9	110.50	21.4	43.0	ETG 2'
TGFHR 26T16-3	26.0	2.80	3.50	2.50	7.9	110.50	21.4	43.0	ETG 3-4-SH*
TGFHR/L 26T23-2	26.0	1.80	2.40	1.65	7.9	110.50	21.4	46.0	ETG 2'
TGFHR/L 26T23-3	26.0	2.80	3.50	2.50	7.9	110.50	21.4	46.0	ETG 3-4-SH*
TGFHR/L 32T22-2	32.0	1.80	2.40	1.65	7.9	110.50	24.8	42.0	ETG 2'
TGFHR/L 32T22-3	32.0	2.80	3.50	2.50	7.9	110.50	24.8	42.0	ETG 3-4-SH*
TGFHR/L 32T33-3	32.0	2.80	3.50	2.50	7.9	110.50	24.8	66.0	ETG 3-4-SH*
TGFHR/L 32T33-4	32.0	3.70	4.50	3.40	7.9	110.50	24.8	66.0	ETG 3-4-SH*

• For user guide, see pages 484-492

⁽¹⁾ Minimum cutting width

⁽²⁾ Maximum cutting width

* Optional, should be ordered separately

For inserts, see pages: TAG N-A (467) • TAG N-C/W/M (463) • TAG N-HF (463) • TAG N-J/JS/JT (465) • TAG N-LF (466) • TAG N-MF (464) • TAG N-UT (467) • TAG R/L-C (464) • TAG R/L-J/JS (466)

For holders, see pages: C#-TBK-R/L (591) • HSK A-WH-TBK-R/L (598) • SGTBF (587) • SGTBK (587) • SGTBR/L (587) • SGTBU/SGTBN (586) • UBHCR/L (587)



TGFHR/L-JHP

Parting and Grooving Reinforced Blades with Channels for High Pressure Coolant Carrying TANG-GRIP Inserts

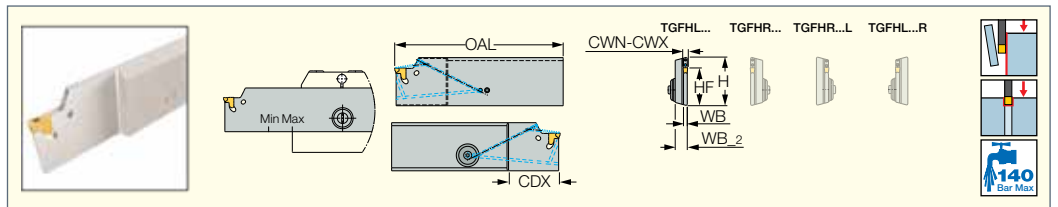

Designation	CWN ⁽¹⁾	CWX ⁽²⁾	WB_2	WB	OAL	H	HF	CDX ⁽³⁾	Insert		
TGFHR/L 32C-3T33-JHP	2.80	3.50	7.9	2.50	110.50	32.0	24.8	33.00	TAG 3	ETG 3-4-SH*	SGC 340
TGFHL 32C-3T33R-JHP	2.80	3.50	7.9	2.50	110.50	32.0	24.8	33.00	TAG 3	ETG 3-4-SH*	SGC 340
TGFHR 32C-3T33L-JHP	2.80	3.50	7.9	2.50	110.50	32.0	24.8	33.00	TAG 3	ETG 3-4-SH*	SGC 340

• For user guide and accessories, see pages 484-492

⁽¹⁾ Minimum cutting width

⁽²⁾ Maximum cutting width

⁽³⁾ Cutting depth maximum

* Optional, should be ordered separately

For inserts, see pages: TAG N-A (467) • TAG N-C/W/M (463) • TAG N-HF (463) • TAG N-J/JS/JT (465) • TAG N-LF (466) • TAG N-MF (464) • TAG N-UT (467) • TAG R/L-C (464) • TAG R/L-J/JS (466)

For holders, see pages: TGTBU-JHP (454)

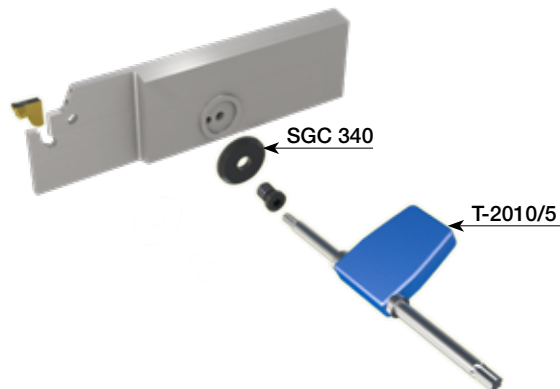

TGSU

Parting and Grooving Flat Top Blades with Tangential Pockets Carrying TANG-GRIP Single-Ended Inserts

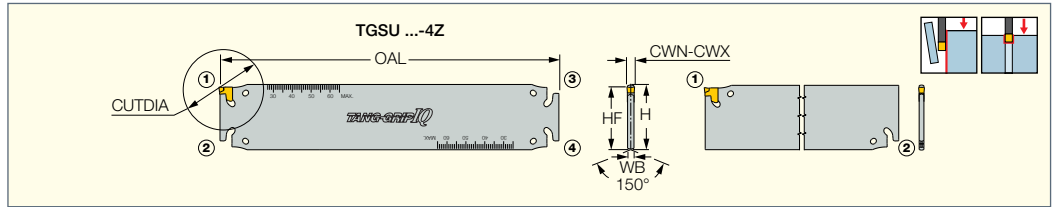

Designation	H	CWN ⁽²⁾	CWX ⁽³⁾	CUTDIA	NOP ⁽⁴⁾	WB	OAL	HF	CSP ⁽⁵⁾	Insert	
TGSU 35-1.4-IQ	35.0	1.40	1.40	35.0	2	2.50 ⁽⁶⁾	180.00	33.2	0	TAG 1.4	ETG 1.4/1.6*
TGSU 35-2-IQ	35.0	1.80	2.40	59.5	2	2.50 ⁽⁷⁾	160.00	33.2	0	TAG 2	ETG 2*
TGSU 35-3-IQ-4Z	35.0	2.80	3.50	120.0	4	2.50	180.00	33.2	0	TAG 3	ETG 3-4-SH*
TGSU 35-4-IQ-4Z	35.0	3.70	4.50	120.0	4	3.40	180.00	33.2	0	TAG 4	ETG 3-4-SH*
TGSU 35-5-IQ	35.0	4.70	5.50	144.0	2	4.00	180.00	33.2	0	TAG 5	ETG 5-7*
TGSU 35-6-IQ	35.0	5.70	6.50	144.0	2	5.20	180.00	33.2	0	TAG 6	ETG 5-7*
TGSU 35-7-IQ	35.0	6.80	7.50	144.0	2	6.00	180.00	33.2	0	TAG 7	ETG 5-7*
TGSU 35C-8-IQ ⁽¹⁾	35.0	7.70	8.50	144.0	2	7.20	180.00	33.2	1	TAG 8	ETG 8-12*
TGSU 35C-9-IQ ⁽¹⁾	35.0	8.70	10.00	144.0	2	8.20	180.00	33.2	1	TAG 9	ETG 8-12*
TGSU 56C-7-IQ ⁽¹⁾	56.0	6.80	7.50	220.0	2	6.00	260.00	53.6	1	TAG 7	ETG 5-7*
TGSU 56C-8-IQ ⁽¹⁾	56.0	7.70	8.50	220.0	2	7.20	260.00	53.6	1	TAG 8	ETG 8-12
TGSU 56C-9-IQ ⁽¹⁾	56.0	8.70	10.00	220.0	2	8.20	260.00	53.6	1	TAG 9	ETG 8-12*

• For user guide, see pages 484-492

⁽¹⁾ C- Internal coolant, use with TGTBU HD blocks only; cooling tube SGCU 341 should be ordered separately

⁽²⁾ Minimum cutting width

⁽³⁾ Maximum cutting width

⁽⁴⁾ Number of pockets

⁽⁵⁾ 0 - Without coolant supply, 1 - With coolant supply

⁽⁶⁾ Thickness at the D.O.C. area is 1.05 mm

⁽⁷⁾ Thickness at the D.O.C. area is 1.65 mm

* Optional, should be ordered separately

For inserts, see pages: TAG N-A (467) • TAG N-C/W/M (463) • TAG N-HF (463) • TAG N-J/JS/JT (465) • TAG N-LF (466) • TAG N-MF (464) • TAG N-UT (467) • TAG R/L-C (464) • TAG R/L-J/JS (466) • TAGB/TAGBA (319)

For holders, see pages: TGTBU (453)

TGSU 35-3-IQ-4
TGSU 35-4-IQ-4



TGTBU

Tool Blocks for TGSU Parting and Grooving Blades

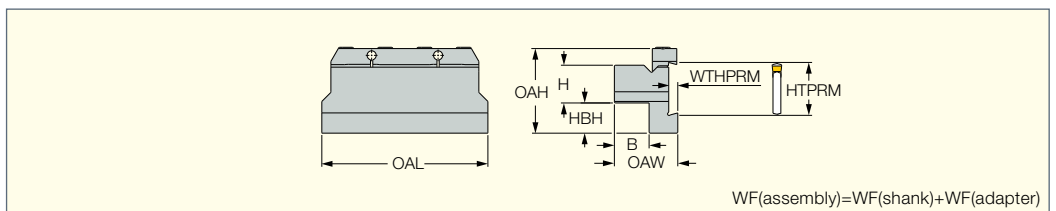

Designation	H	B	HTPRM	WTHPRM	OAW	OAH	HBH	OAL			
TGTBU 20-35	20.0	19.0	35.0	6.00	38.00	56.0	23.7	110.00	BKU 110	SR M6X16 DIN912	HW 5.0
TGTBU 25-35	25.0	23.0	35.0	6.00	42.00	56.0	18.7	110.00	BKU 110	SR M6X16 DIN912	HW 5.0
TGTBU 32-35	32.0	29.0	35.0	6.00	48.00	56.0	11.7	110.00	BKU 110	SR M6X16 DIN912	HW 5.0
TGTBU 32-35 HD ⁽¹⁾	32.0	30.0	35.0	8.00	55.00	64.0	18.0	130.00	BK 509	SR M8X30DIN912	HW 6.0
TGTBU 40-35	40.0	41.0	35.0	6.00	60.00	56.0	3.7	110.00	BKU 110	SR M6X16 DIN912	HW 5.0
TGTBU 40-35 HD ⁽¹⁾	40.0	41.0	35.0	8.00	66.00	64.0	10.0	130.00	BK 509	SR M8X30DIN912	HW 6.0
TGTBU 40-56 HD ⁽¹⁾	40.0	41.0	56.0	8.00	66.00	72.0	28.0	130.00	BK 509	SR M8X30DIN912	HW 6.0

⁽¹⁾ HD - recommended blocks for TGSU...-8, TGSU...-9 blades

For tools, see pages: TGSU (417)



TGTBU-JHP

Tool Blocks for Parting and Grooving Blades for High Pressure Coolant

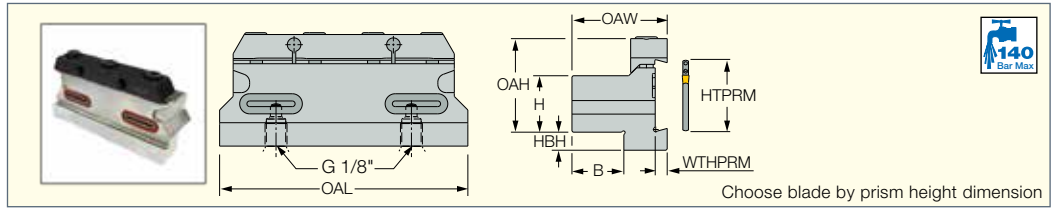

Choose blade by prism height dimension

Designation	H	B	HTPRM	OAW	OAH	HBH	WTHPRM	OAL				
TGTBU 16-5G-JHP	16.0	16.9	26.0	35.60	29.9	13.1	4.10	86.00	BKU 86	SR M6X16 DIN912	HW 5.0	OR 14X2.5N N
TGTBU 20-5G-JHP	20.0	20.9	26.0	39.60	33.9	9.1	4.10	86.00	BKU 86	SR M6X16 DIN912	HW 5.0	OR 14X2.5N N
TGTBU 20-35-JHP	20.0	19.0	35.0	38.00	32.3	23.7	6.00	110.00	BKU 210	SR M6X20 DIN912	HW 5.0	OR 14X2.5N N
TGTBU 20-6G-JHP	20.0	19.0	32.0	39.20	36.4	15.0	5.30	100.00	BKU 100	SR M6X16 DIN912	HW 5.0	OR 14X2.5N N
TGTBU 25-5G-JHP	25.0	26.1	26.0	44.10	39.0	5.5	4.10	110.00	BKU 105	SR M6X16 DIN912	HW 5.0	OR 14X2.5N N
TGTBU 25-6G-JHP	25.0	23.0	32.0	43.20	41.4	8.0	5.30	110.00	BKU 110	SR M6X16 DIN912	HW 5.0	OR 14X2.5N N
TGTBU 25-35-JHP	25.0	23.0	35.0	42.00	37.3	18.7	6.00	110.00	BKU 210	SR M6X20 DIN912	HW 5.0	OR 14X2.5N N
TGTBU 32-6G-JHP	32.0	29.0	32.0	49.20	48.4	5.0	5.30	110.00	BKU 110	SR M6X16 DIN912	HW 5.0	OR 14X2.5N N
TGTBU 32-35-JHP	32.0	29.0	35.0	48.00	44.3	11.7	6.00	110.00	BKU 210	SR M6X20 DIN912	HW 5.0	OR 14X2.5N N

For tools, see pages: DGFH-JHP (253) • DGFHR/L-BC-JHP (427) • TGFH-JHP (451) • TGFHR/L-JHP (452)



TGFH-MB

Parting and Grooving Blades for Other Manufacturers Blocks

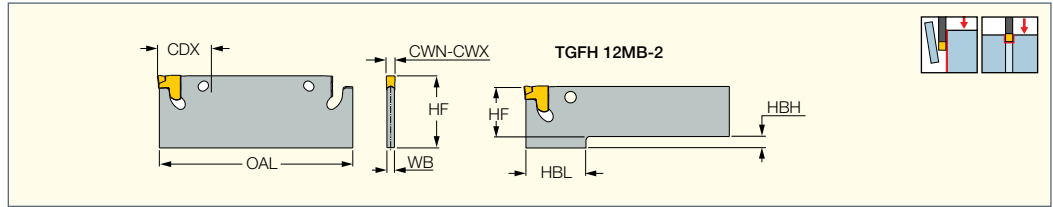

Designation	CWN ⁽¹⁾	CWX ⁽²⁾	WB	OAL	HF	HBH	HBL	CDX ⁽³⁾	Insert	
TGFH 12MB-2 L58	1.80	2.40	1.65	58.00	12.2	2.8	15.5	11.50	TAG 2	ETG 2*
TGFH 17MB-2 L58	1.80	2.40	1.65	58.00	17.2	-	-	11.50	TAG 2	ETG 2*
TGFH 22MB-2 L58	1.80	2.40	1.65	58.00	22.2	-	-	11.50	TAG 2	ETG 2*
TGFH 17MB-3	2.80	3.50	2.50	64.00	17.2	-	-	12.00	TAG 3	ETG 3-4-SH*
TGFH 22MB-3	2.80	3.50	2.50	64.00	22.2	-	-	12.00	TAG 3	ETG 3-4-SH*
TGFH 22MB-3-L84	2.80	3.50	2.50	84.00	22.2	-	-	16.00	TAG 3	ETG 3-4-SH*
TGFH 28MB-3	2.80	3.50	2.50	100.00	28.0	-	-	19.00	TAG 3	ETG 3-4-SH*
TGFH 17MB-4	3.70	4.50	3.40	70.00	17.2	-	-	14.00	TAG 4	ETG 3-4-SH*
TGFH 22MB-4	3.70	4.50	3.40	70.00	22.2	-	-	14.00	TAG 4	ETG 3-4-SH*
TGFH 22MB-4-L90	3.70	4.50	3.40	90.00	22.2	-	-	17.00	TAG 4	ETG 3-4-SH*
TGFH 28MB-4	3.70	4.50	3.40	100.00	28.0	-	-	19.00	TAG 4	ETG 3-4-SH*

* For user guide, see pages 484-492

- ⁽¹⁾ Minimum cutting width
- ⁽²⁾ Maximum cutting width
- ⁽³⁾ Cutting depth maximum

* Optional, should be ordered separately

For inserts, see pages: TAG N-A (467) • TAG N-C/W/M (463) • TAG N-HF (463) • TAG N-J/JS/JT (465) • TAG N-LF (466) • TAG N-MF (464) • TAG N-UT (467) • TAG R/L-C (464) • TAG R/L-J/JS (466)

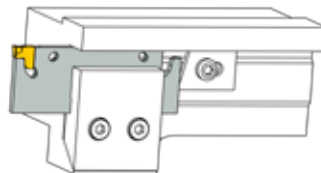

TGAD

Parting and Grooving
Adapters for TANG-GRIP
Tangentially Clamped Inserts

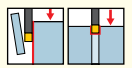
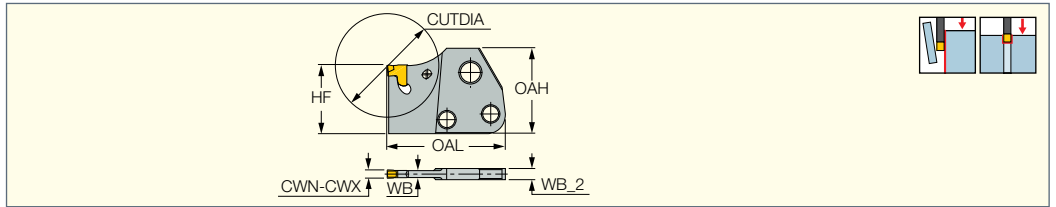

Designation	CWN ⁽¹⁾	CWX ⁽²⁾	WB_2	WB	OAL	CUTDIA	HF	OAH	Insert	
TGAD 1.4N	1.40	1.40	3.20	1.1	41.50	32.0	24.0	29.0	TAG 1.4	ETG 1.4/1.6*
TGAD 2N	1.80	2.40	3.20	1.7	41.50	32.0	24.0	30.0	TAG 2	ETG 2*
TGAD 3N	2.80	3.50	4.00	2.4	41.50	35.0	24.0	30.0	TAG 3	ETG 3-4-SH*
TGAD 4N	3.70	4.50	3.20	3.2	50.50	50.0	24.0	30.0	TAG 4	ETG 3-4-SH*
TGAD 5N	4.70	5.50	4.00	4.0	50.50	50.0	24.0	30.0	TAG 5	ETG 5-7*

• For user guide, see pages 484-492

⁽¹⁾ Minimum cutting width
⁽²⁾ Maximum cutting width

* Optional, should be ordered separately

For inserts, see pages: TAG N-A (467) • TAG N-C/W/M (463) • TAG N-HF (463) • TAG N-J/JS/JT (465) • TAG N-LF (466) • TAG N-MF (464) • TAG N-UT (467) • TAG R/L-C (464) • TAG R/L-J/JS (466)

For holders, see pages: MAHPR/L-JHP (264) • MAHR/L-JHP (263) • MAHR/L (262) • MAHPR/L (264) • C#-MAHD (592) • C#-MAHPD (593) • C#-MAHUR/L (592) • C#-MAHDR-45 (591) • HSK A63WH-MAHUR/L (598) • HSK A63WH-MAHDR-45 (597) • HSK A63WH-MAHDOR (597) • IM-MAHD (599) • C#-MAHD-JHP (593) • C#-MAHPD-JHP (593) • IM-MAHPD (599) • MAHR/L-JHP-MC (263)

MODUGRIP
MODULAR GRIP CARTRIDGES

TGAD RE/LE-JHP

Parting and Grooving Adapters
with Channels for High
Pressure Coolant Carrying
TANG-GRIP Inserts

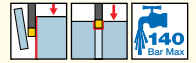
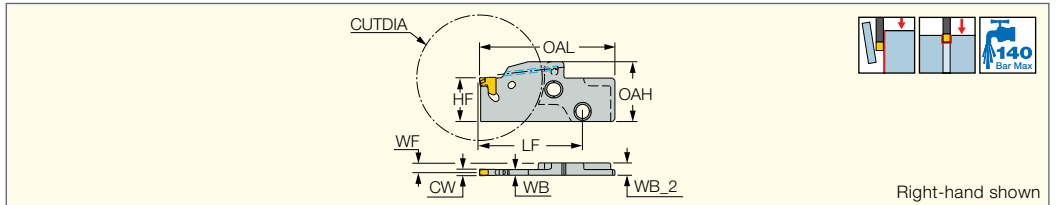

Right-hand shown

Designation	CWN ⁽¹⁾	CWX ⁽²⁾	WF	WB	WB_2	LF	OAL	OAH	HF	CUTDIA	Insert
TGAD 2R/LE-D54-JHP	1.80	2.40	4.48	1.65	5.3	44.40	58.30	25.8	18.9	54.0	TAG 2
TGAD 3LE-D54-JHP	3.00	3.50	4.08	2.45	5.3	44.40	58.30	25.8	18.9	54.0	TAG 3

• For user guide and accessories, see pages 484-492

⁽¹⁾ Minimum cutting width
⁽²⁾ Maximum cutting width

For inserts, see pages: TAG N-A (467) • TAG N-C/W/M (463) • TAG N-HF (463) • TAG N-J/JS/JT (465) • TAG N-LF (466) • TAG N-MF (464) • TAG N-UT (467) • TAG R/L-C (464) • TAG R/L-J/JS (466)

For holders, see pages: NMAHR/L-JHP (458)

Spare Parts

Designation	
TGAD RE/LE-JHP	ETG 3-4-SH*

* Optional, should be ordered separately



TANG-GRIP JETCUT
PARTING LINE
MODULAR-GRIP

TAGPAD-JHP

Parting and Grooving Adapters with Coolant Channels for High Pressure Carrying TANG-GRIP Inserts

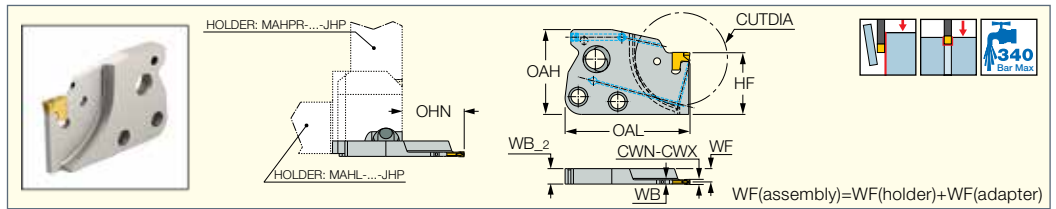

Designation	CWN ⁽¹⁾	CWX ⁽²⁾	CUTDIA	OHN ⁽³⁾	WF	WB	WB_2	OAL	OAH	HF	Insert	
TAGPAD 2R/L-D42-JHP	1.80	2.40	42.0	24.0	5.18	1.65	6.0	48.40	33.0	24.0	TAG 2	ETG 2*
TAGPAD 2R/L-D52-JHP	1.80	2.40	52.0	29.0	5.18	1.65	6.0	53.40	33.0	24.0	TAG 2	ETG 2*
TAGPAD 3L-D42-JHP	2.80	3.50	42.0	24.0	4.80	2.40	6.0	48.40	33.0	24.0	TAG 3	ETG 3-4-SH*
TAGPAD 3L-D52-JHP	2.80	3.50	52.0	29.0	4.80	2.40	6.0	53.40	33.0	24.0	TAG 3	ETG 3-4-SH*

• For user guide and accessories see pages 484-492

⁽¹⁾ Minimum cutting width

⁽²⁾ Maximum cutting width

⁽³⁾ Minimum overhang

* Optional, should be ordered separately

For inserts, see pages: TAG N-A (467) • TAG N-C/W/M (463) • TAG N-HF (463) • TAG N-J/JS/JT (465) • TAG N-LF (466) • TAG N-MF (464) • TAG N-UT (467) • TAG R/L-C (464) • TAG R/L-J/JS (466)

For holders, see pages: ABC MAHDR-#-XL-JHP (532) • BI## MAHD#-#-XL-JHP (525) • BMT## MAHD#-#-XL-JHP (520) • C# MAHD#-#-XL-JHP (523) • HSK T ## MAHD#-#-XL-JHP (524) • MA##### MAHD#-#-XL-JHP (522) • MAHR/L-JHP-MC (263) • MI## MAHD#-#-XL-JHP (526) • MORI## MAHD#-#-XL-JHP (521) • MS##-##-MG-JHP (501) • MS-ES##### GWS-MG-JHP (502) • NT## MAHD#-#-XL-JHP (527) • OKUMA # MAHD#-#-XL-JHP (528) • TR45 MAHDR-#-XL-JHP (530) • V## MAHD#-#-XL-##-JHP (529) • V## MAHD-XL-JHP (530) • VDI##### MAHD#-#-XL-JHP (518) • VDI###-P MAHD#-#-XL-JHP (519)

Flow Rate vs. Pressure

Designation	70 Bar	100 Bar	140 Bar
	Flow Rate (liters/min)	Flow Rate (liters/min)	Flow Rate (liters/min)
TAGPAD 2R/L-D42-JHP	5	6	7
TAGPAD 2R/L-D52-JHP	5	6	7
TAGPAD 3R/L-D42-JHP	8.5	10	12
TAGPAD 3R/L-D52-JHP	8.5	10	12

TANG-GRIP JETCUT
PARTING LINE

TAGPAD-XL-JHP

Parting and Grooving Extra Long Adapters with Channels for High Pressure Coolant Carrying TANG-GRIP Inserts

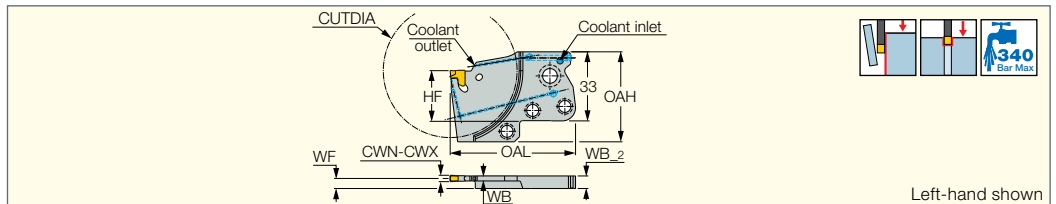

Designation	CWN ⁽¹⁾	CWX ⁽²⁾	WF	WB	WB_2	OAL	OAH	HF	CUTDIA	Insert	
TAGPAD-XL 2R/L-D65-JHP	1.80	2.40	5.20	1.60	6.0	60.00	43.0	34.0	65.0	TAG 2	ETG 2*
TAGPAD-XL 3R/L-D52-JHP	2.80	3.50	4.80	2.40	6.0	53.40	43.0	34.0	52.0	TAG 3	ETG 3-4-SH*
TAGPAD-XL 3L-D65-JHP	2.80	3.50	4.80	2.40	6.0	59.90	43.0	34.0	65.0	TAG 3	ETG 3-4-SH*
TAGPAD-XL 3R/L-D82-JHP	2.80	3.50	4.80	2.40	6.0	70.40	43.0	34.0	82.0	TAG 3	ETG 3-4-SH*
TAGPAD-XL 4L-D52-JHP	3.70	4.50	4.30	3.40	6.0	53.40	43.0	34.0	52.0	TAG 4	ETG 3-4-SH*
TAGPAD-XL 4L-D65-JHP	3.70	4.50	4.30	3.40	6.0	60.00	43.0	34.0	65.0	TAG 4	ETG 3-4-SH*
TAGPAD-XL 4L-D82-JHP	3.70	4.50	4.30	3.40	6.0	70.00	43.0	34.0	82.0	TAG 4	ETG 3-4-SH*
TAGPAD-XL 4R/L-D102-JHP	3.70	4.50	4.30	3.40	6.0	83.00	43.0	34.0	102.0	TAG 4	ETG 3-4-SH*

• For user guide and accessories, see pages 484-492

⁽¹⁾ Minimum cutting width

⁽²⁾ Maximum cutting width

* Optional, should be ordered separately

For inserts, see pages: TAG N-A (467) • TAG N-C/W/M (463) • TAG N-HF (463) • TAG N-J/JS/JT (465) • TAG N-LF (466) • TAG N-MF (464) • TAG N-UT (467) • TAG R/L-C (464) • TAG R/L-J/JS (466)

For holders, see pages: ABC MAHDR-#-XL-JHP (532) • BI## MAHD#-#-XL-JHP (525) • BMT## MAHD#-#-XL-JHP (520) • C# MAHD#-#-XL-JHP (523) • HSK T ## MAHD#-#-XL-JHP (524) • MA##### MAHD#-#-XL-JHP (522) • MAHR/L-MG-XL-JHP (457) • MAHR/L-MG-XL-JHP-MC (457) • MI## MAHD#-#-XL-JHP (526) • MORI## MAHD#-#-XL-JHP (521) • NT## MAHD#-#-XL-JHP (527) • OKUMA # MAHD#-#-XL-JHP (528) • TR TNK36 MAHDL-R-XL-JHP (531) • TR45 MAHDR-#-XL-JHP (530) • TR45TNL MAHDN-R-XL-JHP (531) • V## MAHD#-#-XL-##-JHP (529) • V## MAHD-XL-JHP (530) • VDI##### MAHD#-#-XL-JHP (518) • VDI###-P MAHD#-#-XL-JHP (519)

MAHR/L-MG-XL-JHP
 Holders with High Pressure
 Coolant Channels for
 Interchangeable Adapters

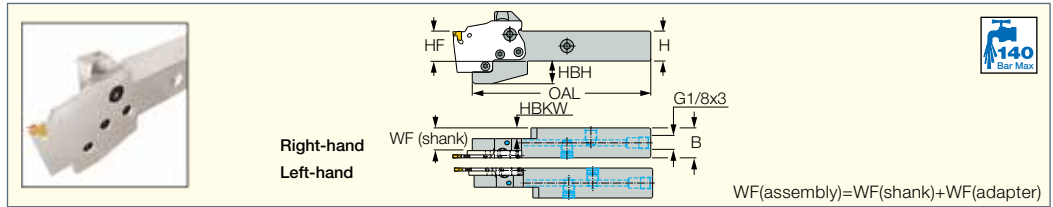

Designation	H	B	OAL	HBH	WF	HBKW
MAHR/L 20-MG-XL-JHP	20.0	20.0	149.10	24.0	14.0	4.00
MAHR/L 25-MG-XL-JHP	25.0	25.0	149.10	19.0	19.0	9.00

• For user guide and accessories, see pages 484-492
 For tools, see pages: DGPAD-XL-JHP (437) • TAGPAD-XL-JHP (456)

Spare Parts

Designation						
MAHR/L 20-MG-XL-JHP	HW 5.0	SR M5-04451	T-20/5	SR M6X14-XT DIN 912	OR 5X1N	PLG 1/8BSP TL360
MAHL 25-MG-XL-JHP	HW 5.0	SR M5-04451	T-20/5	SR M6X14-XT DIN 912	OR 5X1N	PLG 1/8BSP TL360
MAHR 25-MG-XL-JHP	HW 5.0	SR M5-04451	T-20/5	SR M6X14-XT DIN 912	OR 5X1N	PLG 1/8BSP TL360

MAHR/L-MG-XL-JHP-MC
 Holders with Bottom Inlets
 for High Pressure Coolant
 Channels Carrying Parting
 and Grooving Adapters

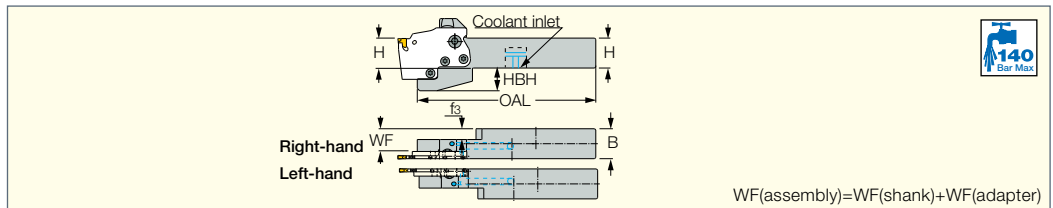

Designation	H	B	OAL	HBH	WF	HBKW
MAHR/L 20-MG-XL-JHP-MC	20.0	20.0	116.10	10.0	14.0	4.00
MAHR/L 25-MG-XL-JHP-MC	25.0	25.0	114.00	10.0	19.0	9.00

• For Tmax, refer to the adapters data
 For tools, see pages: DGPAD-XL-JHP (437) • TAGPAD-XL-JHP (456)

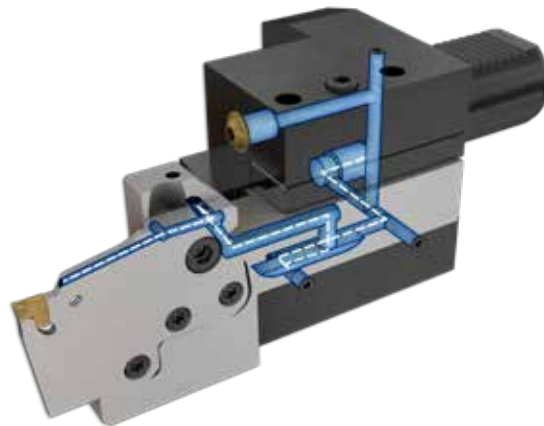

Spare Parts

Designation					
MAHR/L-MG-XL-JHP-MC	SR M6X14-XT DIN 912	HW 5.0	SR M5-04451	T-20/5	OR 5X1N

MODUGRIP JETCUT
MODULAR GRIP CARTRIDGES



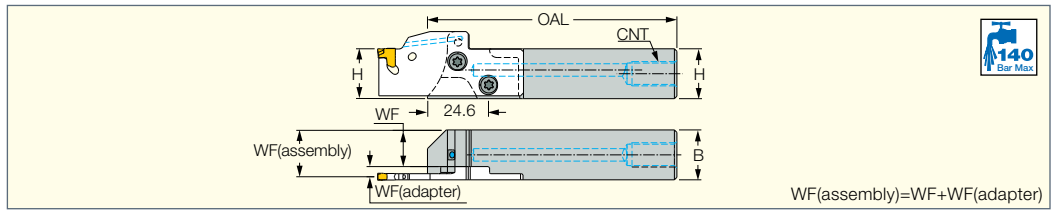

NMAHR/L-JHP
Holders with High Pressure
Coolant Channels for
MODU-GRIP Adapters



Designation	H	B	OAL	WF	CNT
NMAHR/L 20-MG-JHP	20.0	20.0	100.00	14.70	G1/8
NMAHR/L 25-MG-JHP	25.0	25.0	100.00	19.70	G1/8

For tools, see pages: D/HGAD RE/LE-JHP (437) • PCAD RE/LE-JHP (301) • TGAD RE/LE-JHP (455)

Spare Parts

Designation				
NMAHR/L-JHP	SR M5-04451	SW6-T-SH	BLD T20/S7	OR 5X1N

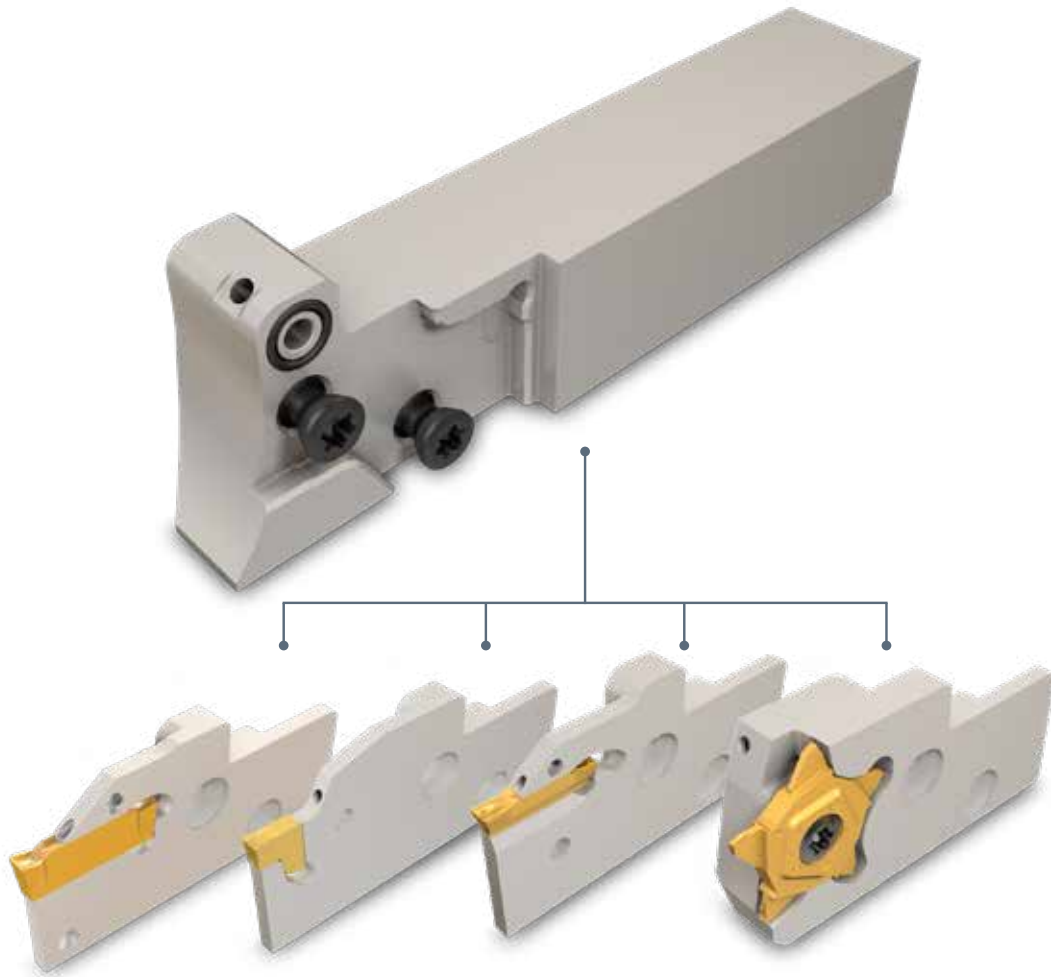

TGFS

Blades for Multi-Spindle Machines - Replacement for HSS and Brazed Tools

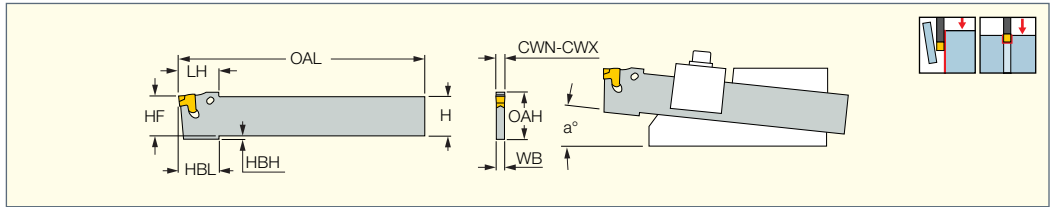

Designation	CWN ⁽¹⁾	CWX ⁽²⁾	H	WB	OAL	OAH	HF	LH	HBL	HBH	CUTDIA	a°	Insert	
TGFS 0-17-2	1.80	2.40	17.2	1.65	110.00	17.2	17.2	-	18.00	1.8	35.0	0	TAG 2	ETG 2*
TGFS 0-17-3	2.80	3.50	17.2	2.50	110.00	19.0	17.2	-	18.00	1.8	60.0	0	TAG 3	ETG 3-4-SH*
TGFS 5-17-2	1.80	2.40	17.4	1.65	110.00	18.9	17.5	18.0	18.00	1.5	35.0	5	TAG 2	ETG 2*
TGFS 5-17-3	2.80	3.50	17.4	2.50	110.00	20.7	17.5	18.0	18.00	1.5	60.0	5	TAG 3	ETG 3-4-SH*
TGFS 5-17-4	3.70	4.50	17.4	3.40	110.00	20.7	17.5	18.0	18.00	1.5	60.0	5	TAG 4	ETG 3-4-SH*
TGFS 5-22-2	1.80	2.40	22.2	1.65	150.00	23.8	22.4	18.0	-	-	50.0	5	TAG 2	ETG 2*
TGFS 5-22-3	2.80	3.50	22.2	2.50	150.00	24.1	22.4	18.0	-	-	75.0	5	TAG 3	ETG 3-4-SH*
TGFS 5-22-4	3.70	4.50	22.2	3.40	150.00	24.1	22.4	18.0	-	-	80.0	5	TAG 4	ETG 3-4-SH*
TGFS 5-28-4	3.70	4.50	28.6	3.40	150.00	30.4	28.7	18.0	-	-	100.0	5	TAG 4	ETG 3-4-SH*

• For user guide, see pages 484-492

⁽¹⁾ Minimum cutting width

⁽²⁾ Maximum cutting width

* Optional, should be ordered separately

For inserts, see pages: TAG N-A (467) • TAG N-C/W/M (463) • TAG N-HF (463) • TAG N-J/JS/JT (465) • TAG N-LF (466) • TAG N-MF (464) • TAG N-UT (467) • TAG R/L-C (464) • TAG R/L-J/JS (466)

TGTR/L-IQ

Integral Shank TANG-GRIP Toolholders for Parting and Grooving

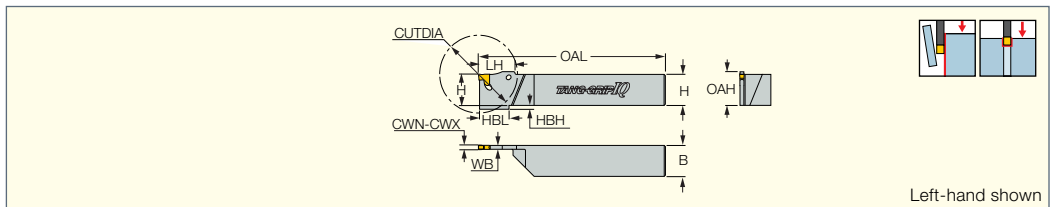

Designation	CWN ⁽²⁾	CWX ⁽³⁾	H	B	WB	OAL	OAH	LH	HBL	HBH	CUTDIA	Insert	
TGTR/L 1010-1.4-IQ	1.40	1.45	10.0	10.0	1.05	140.00	15.0	-	15.50	5.0	20.0	TAG 1.4	ETG 1.4/1.6*
TGTR/L 1212-1.4-IQ	1.40	1.45	12.0	12.0	1.05	140.00	12.0	-	16.00	3.0	30.0	TAG 1.4	ETG 1.4/1.6*
TGTR/L 1616-1.4-IQ	1.40	1.45	16.0	16.0	1.05	140.00	16.0	-	16.00	-	30.0	TAG 1.4	ETG 1.4/1.6*
TGTR/L 2020-1.4-IQ	1.40	1.45	20.0	20.0	1.05	140.00	20.0	-	16.00	-	30.0	TAG 1.4	ETG 1.4/1.6*
TGTR/L 1010-1.6-IQ	1.60	1.64	10.0	10.0	1.30	120.00	-	-	16.00	5.0	28.0	TAG 1.6	ETG 1.4/1.6*
TGTR/L 1212-1.6-IQ	1.60	1.64	12.0	12.0	1.30	120.00	-	-	16.00	3.0	32.0	TAG 1.6	ETG 1.4/1.6*
TGTR/L 1616-1.6-IQ	1.60	1.64	16.0	16.0	1.30	120.00	-	-	16.00	-	35.0	TAG 1.6	ETG 1.4/1.6*
TGTR/L 1010-2-IQ	1.80	2.40	10.0	10.0	1.65	150.00	15.0	-	15.50	5.0	28.0	TAG 2	ETG 2*
TGTR/L 1212-2-IQ	1.80	2.40	12.0	12.0	1.65	150.00	15.0	-	17.00	3.0	32.0	TAG 2	ETG 2*
TGTR/L 1612-2-L120-IQ	1.80	2.50	16.0	12.0	1.65	120.00	16.0	-	16.00	-	35.0	TAG 2	ETG 2*
TGTR/L 1616-2-IQ	1.80	2.40	16.0	16.0	1.65	150.00	16.0	-	16.00	-	35.0	TAG 2	ETG 2*
TGTR/L 2012-2-IQ	1.80	2.40	20.0	12.0	1.65	125.00	20.0	-	16.00	-	35.0	TAG 2	ETG 2*
TGTR/L 1212-3-IQ	2.80	3.50	12.0	12.0	2.50	150.00	19.0	-	19.00	7.0	32.0	TAG 3	ETG 3-4-SH*
TGTR/L 1612-3-L120-IQ	2.80	3.50	16.0	12.0	2.50	120.00	19.0	-	19.00	3.0	35.0	TAG 3	ETG 3-4-SH*
TGTR/L 1616-3-IQ	2.80	3.50	16.0	16.0	2.50	150.00	19.0	-	19.00	3.0	35.0	TAG 3	ETG 3-4-SH*
TGTR/L 2012-3-IQ	2.80	3.50	20.0	12.0	2.50	125.00	20.0	-	19.00	-	43.0	TAG 3	ETG 3-4-SH*
TGTR/L 2020-3-IQ	2.80	3.50	20.0	20.0	2.50	120.50	21.7	23.4	19.00	-	54.0	TAG 3	ETG 3-4*
TGTR/L 2525-3-IQ	2.80	3.50	25.0	25.0	2.50	150.50	26.7	23.4	19.00	-	56.0	TAG 3	ETG 3-4*
TGTR/L 2525K-3 ⁽¹⁾	2.80	3.50	25.0	25.0	2.50	150.00	26.7	23.4	19.00	-	56.0	TAG 3	ETG 3-4*
TGTR/L 2020-4-IQ	3.70	4.50	20.0	20.0	3.40	120.50	21.7	23.4	19.00	-	57.0	TAG 4	ETG 3-4*
TGTR/L 2525-4-IQ	3.70	4.50	25.0	25.0	3.40	150.50	26.7	23.4	19.00	-	65.0	TAG 4	ETG 3-4*
TGTR/L 2020-5-IQ	4.70	5.50	20.0	20.0	4.00	120.00	21.7	-	19.00	-	57.0	TAG 5	ETG 5-7*
TGTR/L 2525-5-IQ	4.70	5.50	25.0	25.0	4.00	150.00	25.0	-	19.00	-	76.0	TAG 5	ETG 5-7*
TGTR/L 2525-6-IQ	5.70	6.50	25.0	25.0	5.20	150.00	25.0	-	19.00	-	76.0	TAG 6	ETG 5-7*

• For user guide, see pages 484-492

⁽¹⁾ With coolant

⁽²⁾ Minimum cutting width

⁽³⁾ Maximum cutting width

* Optional, should be ordered separately

For inserts, see pages: TAG N-A (467) • TAG N-C/W/M (463) • TAG N-HF (463) • TAG N-J/JS/JT (465) • TAG N-LF (466) • TAG N-MF (464) • TAG N-UT (467) • TAG R/L-C (464) • TAG R/L-J/JS (466) • TAGB/TAGBA (319)

For holders, see pages: C#-ASHR/L-45-HPMC (675) • C#-ASHR/L-HPMC (675)

TANG-GRIP
 350 LINE

TGTR/L-IQ-2Z

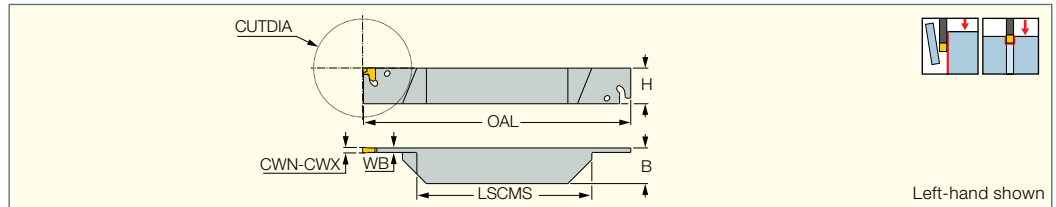
 Integral Shank TANG-GRIP
 Toolholders with 2 Pockets
 for Parting and Grooving

Designation	CWN ⁽¹⁾	CWX ⁽²⁾	CUTDIA	H	B	WB	OAL	LSCMS	Insert	
TGTR/L 2020-3-IQ-2Z	2.80	3.50	54.0	20.0	20.0	2.50	150.00	98.90	TAG 3	ETG 3-4-SH*
TGTR/L 2525-3-IQ-2Z	2.80	3.50	56.0	25.0	25.0	2.50	150.00	98.00	TAG 3	ETG 3-4-SH*
TGTR/L 2020-4-IQ-2Z	3.70	4.50	57.0	20.0	20.0	3.40	150.00	95.00	TAG 4	ETG 3-4-SH*
TGTR/L 2525-4-IQ-2Z	3.70	4.50	65.0	25.0	25.0	3.40	150.00	88.00	TAG 4	ETG 3-4-SH*

• For user guide, see pages 484-492

⁽¹⁾ Minimum cutting width

⁽²⁾ Maximum cutting width

* Optional, should be ordered separately

For inserts, see pages: TAG N-A (467) • TAG N-C/W/M (463) • TAG N-HF (463) • TAG N-J/JS/JT (465) • TAG N-LF (466) • TAG N-MF (464) • TAG N-UT (467) • TAG R/L-C (464) • TAG R/L-J/JS (466)

For holders, see pages: C#-ASHR/L-45-HPMC (675) • C#-ASHR/L-HPMC (675)

TANG-GRIP JETCUT
 PARTING LINE

TGTR/L-JHP

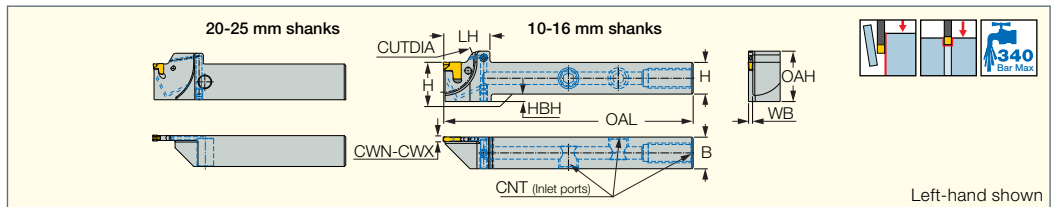
 Parting and Grooving Tools
 with Channels for High
 Pressure Coolant Carrying
 TANG-GRIP Inserts

Designation	CWN ⁽¹⁾	CWX ⁽²⁾	H	B	WB	OAL	OAH	LH	HBH	CNT	CUTDIA	Insert
TGTR/L 1010-2JHP	1.80	2.50	10.0	10.0	1.72	100.00	19.5	18.5	5.0	UNF 5/16-24	24.0	TAG 2
TGTR/L 1212-2JHP	1.80	2.50	12.0	12.0	1.72	100.00	19.5	18.5	3.0	UNF 5/16-24	24.0	TAG 2
TGTR/L 1616-2JHP	1.80	2.50	16.0	16.0	1.72	120.00	21.5	25.5	-	UNF 5/16-24	35.0	TAG 2
TGTR/L 2012-2JHP	1.80	2.50	20.0	12.0	1.72	120.00	25.6	25.5	-	UNF 5/16-24	35.0	TAG 2
TGTR/L 1616-3JHP	2.80	3.50	16.0	16.0	2.50	120.00	24.5	25.5	3.0	UNF 5/16-24	35.0	TAG 3
TGTR/L 2020-3JHP	2.80	3.50	20.0	20.0	2.50	120.00	27.0	35.0	-	G 1/8-28	54.0	TAG 3
TGTR/L 2525-3JHP	2.80	3.50	25.0	25.0	2.50	150.00	32.5	35.0	-	G 1/8-28	56.0	TAG 3
TGTR/L 2020-4JHP	3.70	4.50	20.0	20.0	3.40	120.00	27.0	35.0	-	G 1/8-28	54.0	TAG 4
TGTR/L 2525-4JHP	3.70	4.50	25.0	25.0	3.40	150.00	32.5	35.0	-	G 1/8-28	56.0	TAG 4

• For user guide and accessories, see pages 484-492

⁽¹⁾ Minimum cutting width

⁽²⁾ Maximum cutting width

For inserts, see pages: TAG N-A (467) • TAG N-C/W/M (463) • TAG N-HF (463) • TAG N-J/JS/JT (465) • TAG N-LF (466) • TAG N-MF (464) • TAG N-UT (467) • TAG R/L-C (464) • TAG R/L-J/JS (466)

Flow Rate vs. Pressure

Designation	70 Bar	100 Bar	140 Bar
	Flow Rate (liters/min)	Flow Rate (liters/min)	Flow Rate (liters/min)
TGTR/L...-2JHP	2-4	4-6	6-8
TGTR/L...-3JHP	7-9	9-11	11-13
TGTR/L...-4JHP	7-9	9-11	11-13

Spare Parts

Designation					
TGTR/L 1010-2JHP	ETG 2-SH-T*		SR 5/16XUNF-TL-S		HW 5/32*
TGTR/L 1212-2JHP	ETG 2-SH-T*		SR 5/16UNF TL360		HW 5/32*
TGTR/L 1616-2JHP	ETG 2*		SR 5/16UNF TL360		HW 5/32*
TGTR/L 2012-2JHP	ETG 2*		SR 5/16UNF TL360		HW 5/32*
TGTR/L 1616-3JHP	ETG 3-4-SH*		SR 5/16UNF TL360		HW 5/32*
TGTR/L 2020-3JHP	ETG 3-4-SH*	PLUG G1/8-6.5 TL360		HW 5.0	
TGTR/L 2525-3JHP	ETG 3-4-SH*	PLUG G1/8-6.5 TL360	SR 5/16UNF TL360	HW 5.0	HW 5/32*
TGTR/L 2020-4JHP	ETG 3-4-SH*	PLUG G1/8-6.5 TL360	SR 5/16UNF TL360	HW 5.0	
TGTR/L 2525-4JHP	ETG 3-4-SH*	PLUG G1/8-6.5 TL360	SR 5/16UNF TL360	HW 5.0	HW 5/32*

* Optional, should be ordered separately

TGTR/L-JHP-MC
Parting and Grooving Toolholders with Bottom Inlets for High Pressure Coolant Carrying TANG-GRIP Inserts

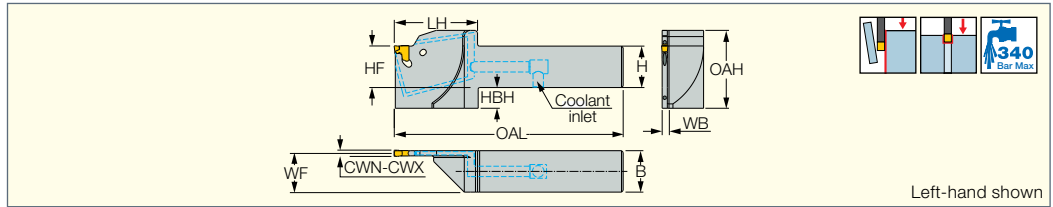

Designation	CWN ⁽¹⁾	CWX ⁽²⁾	H	B	HF	WB	OAL	OAH	LH	HBH	CUTDIA ⁽³⁾	Insert
TGTR/L 2020-D42-2-JHP-MC	1.80	2.50	20.0	20.0	20.0	1.72	99.00	25.7	29.0	-	42.0	TAG 2
TGTR/L 2020-D65-3-JHP-MC	2.80	3.50	20.0	20.0	20.1	2.50	110.50	37.6	40.5	10.0	65.0	TAG 3
TGTR/L 2020-D82-3-JHP-MC	2.80	3.50	20.0	20.0	20.1	2.50	119.00	38.8	49.0	10.0	82.0	TAG 3
TGTR/L 2525-D65-3-JHP-MC	2.80	3.50	25.0	25.0	25.1	2.50	126.00	37.6	41.0	5.0	65.0	TAG 3
TGTR/L 2525-D82-3-JHP-MC	2.80	3.50	25.0	25.0	25.1	2.50	134.50	38.8	49.5	5.0	82.0	TAG 3

• For user guide and accessories, see pages 484-492

- (1) Minimum cutting width
- (2) Maximum cutting width
- (3) Maximum cutting diameter

For inserts, see pages: TAG N-A (467) • TAG N-C/W/M (463) • TAG N-HF (463) • TAG N-J/JS/JT (465) • TAG N-LF (466) • TAG N-MF (464) • TAG N-UT (467) • TAG R/L-C (464) • TAG R/L-J/JS (466)

For holders, see pages: V-ASH-MC (532)

Spare Parts

Designation	
TGTL 2020-D42-2-JHP-MC	ETG 2*
TGTR 2020-D42-2-JHP-MC	ETG 2*
TGTL 2020-D65-3-JHP-MC	ETG 3-4-SH*
TGTR 2020-D65-3-JHP-MC	ETG 3-4-SH*
TGTL 2020-D82-3-JHP-MC	ETG 3-4-SH*
TGTR 2020-D82-3-JHP-MC	ETG 3-4-SH*
TGTL 2525-D65-3-JHP-MC	ETG 3-4-SH*
TGTR 2525-D65-3-JHP-MC	ETG 3-4-SH*
TGTL 2525-D82-3-JHP-MC	ETG 3-4-SH*
TGTR 2525-D82-3-JHP-MC	ETG 3-4-SH*

* Optional, should be ordered separately

TGTR/L-2T.SH-L120
Integral Shank Short-Head TANG-GRIP Toolholders for Parting and Grooving

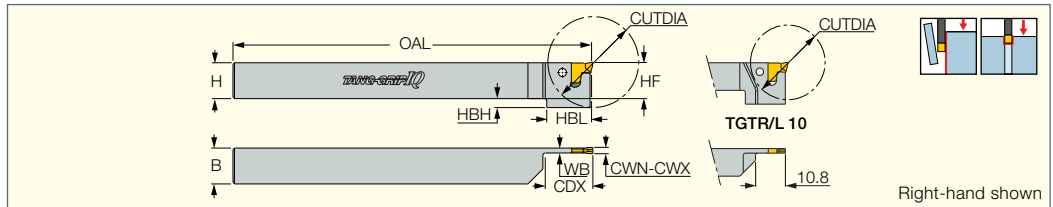

Designation	CWN ⁽¹⁾	CWX ⁽²⁾	H	HF	B	WB	OAL	HBL	HBH	CDX ⁽³⁾	CUTDIA ⁽⁴⁾	
TGTR/L 1010-2T10SH-L120-IQ	1.80	2.50	10.0	10.1	10.0	1.65	120.00	15.0	5.0	10.00	26.0	ETG 2-SH-T*
TGTR/L 1212-2T15SH-L120-IQ	1.80	2.50	12.0	12.1	12.0	1.65	120.00	15.0	3.0	15.00	30.0	ETG 2-SH-T*
TGTR/L 1616-2T18SH-L120-IQ	1.80	2.50	16.0	16.1	16.0	1.65	120.00	-	-	18.00	36.0	ETG 2-SH-T*

• For user guide, see pages 484-492

- (1) Minimum cutting width
- (2) Maximum cutting width
- (3) Cutting depth maximum
- (4) For parting

* Optional, should be ordered separately

For inserts, see pages: TAG N-A (467) • TAG N-C/W/M (463) • TAG N-J/JS/JT (465) • TAG N-LF (466) • TAG N-MF (464) • TAG N-UT (467) • TAG R/L-C (464) • TAG R/L-J/JS (466)



TGTR/L-D

Integral Shank TANG-GRIP
Toolholders with Reinforced
Blades for Parting and Grooving
Mainly Sub-Spindle Machines

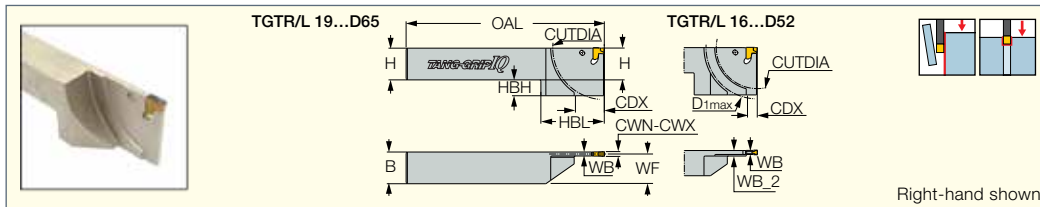

Designation	CW	CWN ⁽¹⁾	CWX ⁽²⁾	H	B	WB	WB_2	OAL	HBL	WF	HBH	CUTDIA	D _{1 max}	CDX	Insert	
TGTR/L 1616-2-D52-IQ	2.00	1.80	2.40	16.0	16.0	1.65	3.50	125.00	40.0	15.20	14.0	52.0	65.0	6.00	TAG 2	ETG 2*
TGTR/L 2020-2-D65-IQ	2.00	1.80	2.40	20.0	20.0	1.65	-	125.00	40.0	19.20	10.0	65.0	-	18.00	TAG 2	ETG 2*
TGTR/L 1616-3-D52-IQ	3.00	2.80	3.50	16.0	16.0	2.50	3.50	125.00	40.0	14.80	14.0	52.0	65.0	6.00	TAG 3	ETG 3-4-SH*
TGTR/L 2020-3-D65-IQ	3.00	2.80	3.50	20.0	20.0	2.50	-	125.00	40.0	18.80	10.0	65.0	-	18.00	TAG 3	ETG 3-4-SH*

• For user guide, see pages 484-492

⁽¹⁾ Minimum cutting width

⁽²⁾ Maximum cutting width

* Optional, should be ordered separately

For inserts, see pages: TAG N-A (467) • TAG N-C/W/M (463) • TAG N-HF (463) • TAG N-J/JS/JT (465) • TAG N-LF (466) • TAG N-MF (464) • TAG N-UT (467) • TAG R/L-C (464) • TAG R/L-J/JS (466)

Depth Capacity DGTR/L-D

Table Determining Depth of Cut
Function of Workpiece Diameter

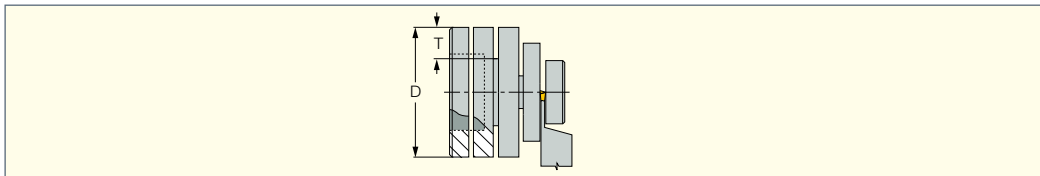

Designation	T _{max}									
TGTR/L 1616-2-D52-IQ	20	25	19	16	15	13	11	10	9	8
TGTR/L 2020-2-D65-IQ	20	25	30	31	29	26	24	23	22	20
TGTR/L 1616-3-D52-IQ	20	25	20	17	15	13	11	10	9	8
TGTR/L 2020-3-D65-IQ	20	25	30	31	29	26	24	23	22	20
D →	40	50	60	70	80	100	120	150	200	300



TGFHL-TR

Reinforced Blades for TRAUB and
Index Machines Carrying TANG-
GRIP Tangentially Clamped Inserts

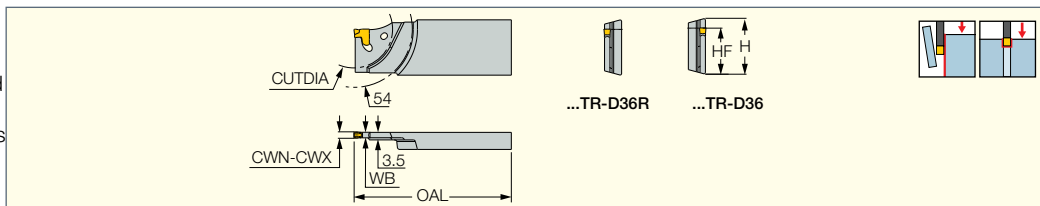

Designation	H	CWN ⁽¹⁾	CWX ⁽²⁾	WB	OAL	HF	CUTDIA	Insert	
TGFHL 26-2TR-D36	26.0	1.80	2.40	1.65	110.00	21.4	36.0	TAG 2	ETG 2*
TGFHL 26-2TR-D36R	26.0	1.80	2.40	1.65	110.00	21.4	36.0	TAG 2	ETG 2*
TGFHL 26-3TR-D36	26.0	2.80	3.50	2.50	110.00	21.4	36.0	TAG 3	ETG 3-4-SH*
TGFHL 26-3TR-D36R	26.0	2.80	3.50	2.50	110.00	21.4	36.0	TAG 3	ETG 3-4-SH*

• For user guide, see pages 484-492

⁽¹⁾ Minimum cutting width

⁽²⁾ Maximum cutting width

* Optional, should be ordered separately

For inserts, see pages: TAG N-A (467) • TAG N-C/W/M (463) • TAG N-HF (463) • TAG N-J/JS/JT (465) • TAG N-LF (466) • TAG N-MF (464) • TAG N-UT (467) • TAG R/L-C (464) • TAG R/L-J/JS (466)

For holders, see pages: SGTBR/L (587) • SGTBU/SGTBN (586) • UBHCR/L (587)

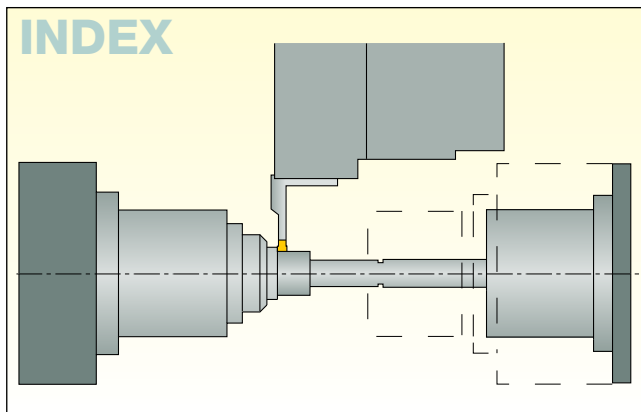
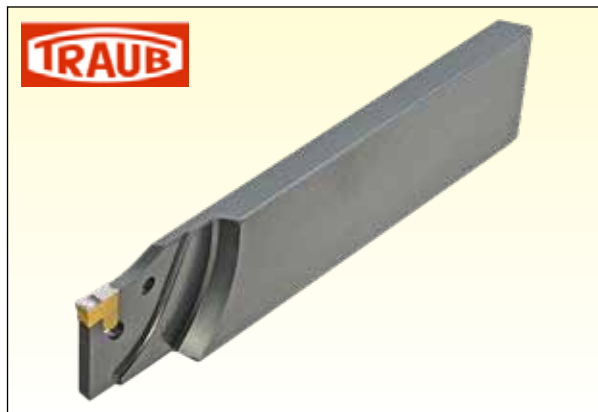

TAG N-HF

Single-Ended Inserts for High Feed Parting & Grooving, Hard Materials and Tough Applications

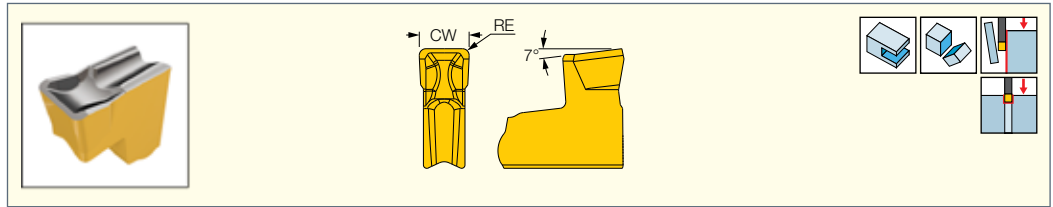

Designation	Dimensions			Tough ↔ Hard		Recommended Machining Data
	CW	CWTOL ⁽¹⁾	RE	IC830	IC808	f groove (mm/rev)
TAG N3HF	3.00	0.040	0.40	●	●	0.25-0.35
TAG N4HF	4.00	0.040	0.50	●	●	0.30-0.40
TAG N5HF	5.00	0.040	0.50	●	●	0.30-0.40

• For cutting speed recommendations and user guide, see pages 484-492

⁽¹⁾ Cutting width tolerance (+/-)

For tools, see pages: ADMP D45 (472) • TAGPAD-JHP (456) • TAGPAD-XL-JHP (456) • TGAD (455) • TGAD RE/LE-JHP (455) • TGFH-JHP (451) • TGFH-MB (454) • TGFH-S (451) • TGFH/R/L (318) • TGFHL-TR (462) • TGFHR/L (452) • TGFHR/L-JHP (452) • TGFS (459) • TGTR/L-D (462) • TGTR/L-IQ (459) • TGTR/L-IQ-2Z (460) • TGTR/L-JHP-MC (461)

TAG N-C/W/M

Single-Ended Inserts for Parting, Grooving and Slitting Bars, Hard Materials and Tough Applications

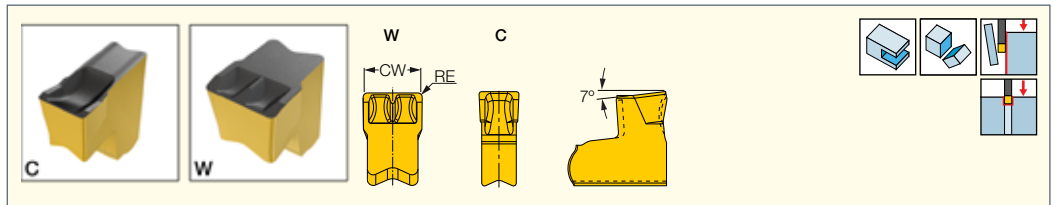

Designation	Dimensions			Tough ↔ Hard									Recommended Machining Data	
	CW	CWTOL ⁽³⁾	RE	IC830	IC928	IC1030	IC5400	IC1010	IC808	IC908	IC30N	IC20	IC807	f groove (mm/rev)
TAG N1.4C	1.40	0.04	0.16										●	0.04-0.10
TAG N1.6C	1.60	0.04	0.16	●					●					0.04-0.14
TAG N2C	2.00	0.04	0.20	●		●	●	●	●		●	●		0.05-0.16
TAG N2.4C	2.40	0.04	0.16	●					●					0.06-0.18
TAG N3CB (1)	3.00	0.04	0.35	●					●					0.12-0.30
TAG N3C	3.05	0.04	0.20	●	●	●	●	●	●	●	●	●	●	0.10-0.25
TAG N3M (2)	3.05	0.04	0.20	●					●	●				0.06-0.18
TAG N3W	3.05	0.04	0.20	●					●	●				0.10-0.25
TAG N4C	4.00	0.04	0.24	●	●	●	●	●	●	●		●	●	0.10-0.30
TAG N4CB (1)	4.00	0.04	0.40	●					●	●				0.10-0.33
TAG N4M (2)	4.00	0.04	0.24	●					●	●				0.06-0.20
TAG N4W	4.00	0.04	0.24	●					●	●				0.10-0.30
TAG N4.8C	4.80	0.04	0.30	●					●					0.10-0.35
TAG N5C	5.05	0.04	0.25	●					●					0.10-0.35
TAG N6.3C	6.30	0.04	0.35	●					●					0.15-0.40
TAG N7W	7.00	0.08	0.50	●					●					0.18-0.40
TAG N8C	8.00	0.10	0.50	●					●					0.20-0.70
TAG N9.5C	9.50	0.10	0.50	●					●					0.25-0.80
TAG N9.5W	9.50	0.05	0.50	●					●					0.22-0.80
TAG N12.7W	12.70	0.10	0.85	●					●					0.30-0.80

• Feed values for grade IC20 should be decreased by 50% • For cutting speed recommendations and user guide, see pages 484-492

⁽¹⁾ Larger corner radii for interrupted cut and high feed applications

⁽²⁾ Similar to C-type, but with a modified edge; improved chip control at medium feeds

⁽³⁾ Cutting width tolerance (+/-)

For tools, see pages: ADMP D45 (472) • Anti-Vibration Blades (268) • TAGPAD-JHP (456) • TAGPAD-XL-JHP (456) • TGAD (455) • TGAD RE/LE-JHP (455) • TGBHR/L (316) • TGBHR/L-JHP (317) • TGFH-JHP (451) • TGFH-MB (454) • TGFH-S (451) • TGFH/R/L (318) • TGFHL-TR (462) • TGFHR/L (452) • TGFHR/L-JHP (452) • TGFS (459) • TGSU (417) • TGTR/L-2T.SH-L120 (461) • TGTR/L-D (462) • TGTR/L-IQ (459) • TGTR/L-IQ-2Z (460) • TGTR/L-JHP (460) • TGTR/L-JHP-MC (461)

TANG-GRIP

PARTING LINE

TAG R/L-C

Single-Ended Inserts for Parting Bars, Hard Materials and Tough Parting Applications

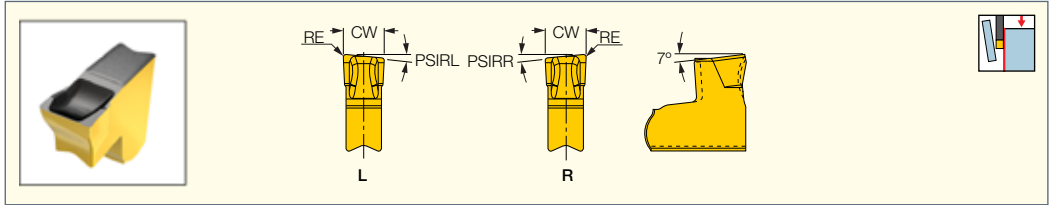

Designation	Dimensions					Tough ↔ Hard					Recommended Machining Data f groove (mm/rev)
	CW	CWTOL ⁽¹⁾	RE	PSIRR	PSIRL	IC830	IC928	IC808	IC908	IC30N	
TAG L2C-6D	2.05	0.10	0.20	-	6.0	●		●			0.04-0.12
TAG R2C-6D	2.05	0.10	0.20	6.0	-	●		●			0.04-0.12
TAG R2.4C-8D	2.40	0.10	0.16	8.0	-			●			0.05-0.13
TAG L3C-6D	3.00	0.10	0.20	-	6.0	●	●	●	●		0.08-0.18
TAG R3C-6D	3.00	0.10	0.20	6.0	-	●	●	●	●		0.08-0.18
TAG R3C-8D	3.00	0.10	0.20	8.0	-					●	0.06-0.16
TAG L3C-15D	3.00	0.10	0.20	-	15.0	●	●	●	●		0.08-0.16
TAG R3C-15D	3.00	0.10	0.20	15.0	-	●	●	●	●		0.08-0.16
TAG L4C-4D	4.05	0.10	0.24	-	4.0	●		●			0.08-0.20
TAG R4C-4D	4.05	0.10	0.24	4.0	-	●	●	●	●		0.08-0.20
TAG L5C-4D	5.05	0.10	0.25	-	4.0	●		●			0.10-0.25
TAG R5C-4D	5.05	0.10	0.25	4.0	-	●		●			0.10-0.25
TAG L6.3C-4D	6.35	0.10	0.35	-	4.0	●		●			0.12-0.30
TAG R6.3C-4D	6.35	0.10	0.35	4.0	-	●		●			0.12-0.30

• For cutting speed recommendations and user guide, see pages 484-492

⁽¹⁾ Cutting width tolerance (+/-)

TANG-GRIP

PARTING LINE

TAG N-MF

Single-Ended Inserts for Parting, Grooving and Slitting Stainless and Alloy Steel at Medium Feed

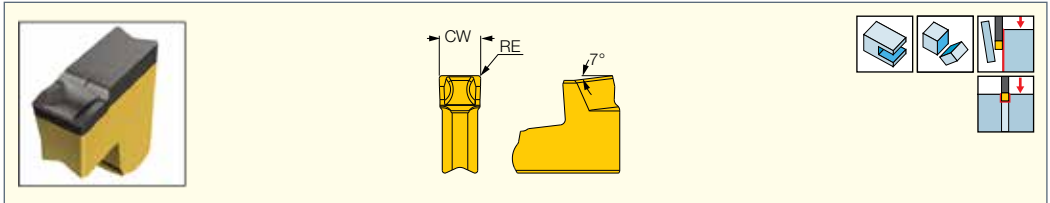

Designation	Dimensions			Tough ↔ Hard					Recommended Machining Data f groove (mm/rev)
	CW	CWTOL ⁽¹⁾	RE	IC830	IC1030	IC5400	IC1010	IC808	
TAG N2MF	2.00	0.05	0.20	●	●	●	●	●	0.04-0.12
TAG N3MF	3.00	0.05	0.20	●	●	●	●	●	0.06-0.18
TAG N4MF	4.00	0.05	0.25	●	●	●	●	●	0.07-0.22
TAG N5MF	5.00	0.05	0.25	●				●	0.08-0.25

• For cutting speed recommendations and user guide, see pages 484-492

⁽¹⁾ Cutting width tolerance (+/-)

For tools, see pages: ADMP D45 (472) • TAGPAD-JHP (456) • TAGPAD-XL-JHP (456) • TGAD (455) • TGAD RE/LE-JHP (455) • TGFH-JHP (451) • TGFH-MB (454) • TGFH-S (451) • TGFH/R/L (318) • TGFHL-TR (462) • TGFHR/L (452) • TGFHR/L-JHP (452) • TGFS (459) • TGTR/L-2T.SH-L120 (461) • TGTR/L-D (462) • TGTR/L-IQ (459) • TGTR/L-IQ-2Z (460) • TGTR/L-JHP (460) • TGTR/L-JHP-MC (461)

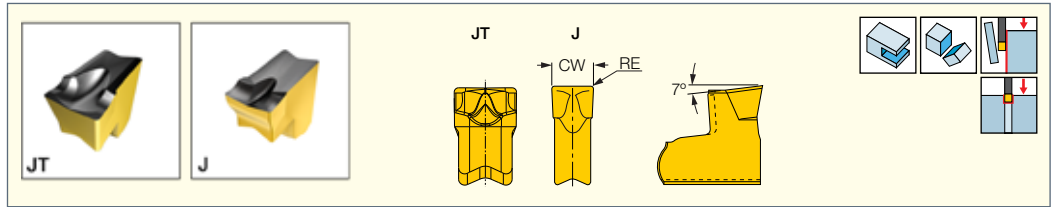

Designation	Dimensions				Tough ↔ Hard									Recommended Machining Data
	CW	RE	CWTOL ⁽²⁾	RETOL ⁽³⁾	IC830	IC928	IC1030	IC5400	IC1010	IC808	IC908	IC20	IC807	
TAG N1.4J	1.40	0.16	0.04	0.03	●					●			●	0.03-0.10
TAG N1.6J	1.60	0.16	0.04	0.03	●					●			●	0.03-0.12
TAG N2J	2.00	0.20	0.04	0.04	●		●	●	●	●		●	●	0.04-0.12
TAG N2JS⁽¹⁾	2.00	0.02	0.04	0.02	●					●			●	0.03-0.08
TAG N2JT	2.00	0.20	0.04	0.04	●	●		●		●	●		●	0.04-0.10
TAG N3J	3.05	0.20	0.04	0.03	●	●	●	●	●	●	●	●	●	0.04-0.16
TAG N3JS⁽¹⁾	3.05	0.02	0.04	0.02	●					●			●	0.04-0.10
TAG N3JT	3.05	0.20	0.04	0.03	●			●		●	●		●	0.05-0.18
TAG N3.2JT	3.25	0.20	0.04	0.03	●					●			●	0.05-0.18
TAG N4J	4.00	0.24	0.04	0.03	●	●	●	●	●	●	●		●	0.04-0.18
TAG N4JT	4.05	0.24	0.04	0.03	●			●		●	●		●	0.06-0.20
TAG N5J	5.05	0.25	0.04	0.04	●					●			●	0.05-0.20
TAG N5JT	5.05	0.25	0.04	0.04	●					●	●		●	0.06-0.22
TAG N6.3J	6.35	0.34	0.04	0.04	●					●			●	0.06-0.22
TAG N6.3JT	6.35	0.34	0.04	0.04	●					●	●		●	0.08-0.25
TAG N7JT	7.05	0.50	0.04	0.04	●					●			●	0.10-0.28

• JT chipformer has the basic positive configuration of the J-type and a reinforced negative frontal edge; most suitable for soft materials at low to medium feeds.

• For cutting speed recommendations and user guide, see pages 484-492

⁽¹⁾ Sharp corners cannot be used on TGSF slitting cutters

⁽²⁾ Cutting width tolerance (+/-)

⁽³⁾ Corner radius tolerance (+/-)

For tools, see pages: ADMP D45 (472) • TAGPAD-JHP (456) • TAGPAD-XL-JHP (456) • TGAD (455) • TGAD RE/LE-JHP (455) • TGBHR/L (316) • TGFH-JHP (451) • TGFH-MB (454) • TGFH-S (451) • TGFH/R/L (318) • TGFHL-TR (462) • TGFHR/L (452) • TGFHR/L-JHP (452) • TGFS (459) • TGSU (417) • TGTR/L-2T.SH-L120 (461) • TGTR/L-D (462) • TGTR/L-IQ (459) • TGTR/L-IQ-2Z (460) • TGTR/L-JHP (460) • TGTR/L-JHP-MC (461)



TANG-GRIP
 PARTING LINE

TAG R/L-J/JS

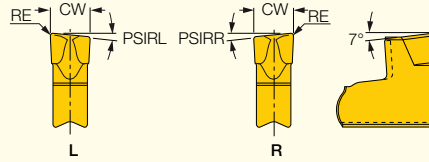
 TANG-GRIP Inserts for Parting
 Soft Materials, Tubes, Small
 Diameters and Thin-Walled Parts

Designation	Dimensions				Tough ↔ Hard					Recommended Machining Data
	CW	RE	PSIRL	PSIRR	IC830	IC928	IC808	IC908	IC807	
TAG L1.4J-8D	1.40	0.16	8.0	-	●		●		●	0.03-0.08
TAG R1.4J-8D	1.40	0.16	-	8.0	●		●		●	0.03-0.08
TAG L1.4JS-10D (1)	1.40	0.02	10.0	-	●		●		●	0.02-0.06
TAG R1.4JS-10D (1)	1.40	0.02	-	10.0	●		●		●	0.02-0.06
TAG L2J-6D	2.00	0.20	6.0	-	●		●			0.03-0.10
TAG R2J-6D	2.00	0.20	-	6.0	●		●			0.03-0.10
TAG L2JS-6D (1)	2.00	0.02	6.0	-	●		●			0.02-0.08
TAG R2JS-6D (1)	2.00	0.02	-	6.0	●		●			0.02-0.08
TAG L2J-15D	2.00	0.20	15.0	-	●		●			0.03-0.08
TAG R2J-15D	2.00	0.20	-	15.0	●		●			0.03-0.08
TAG L2JS-15D (1)	2.00	0.02	15.0	-	●		●			0.02-0.06
TAG R2JS-15D (1)	2.00	0.02	-	15.0	●		●			0.02-0.06
TAG L3J-6D	3.00	0.20	6.0	-	●	●	●	●		0.04-0.14
TAG R3J-6D	3.00	0.20	-	6.0	●	●	●	●		0.04-0.14
TAG L3JS-6D (1)	3.00	0.02	6.0	-	●		●			0.03-0.10
TAG R3JS-6D (1)	3.00	0.02	-	6.0	●		●			0.03-0.10
TAG L3J-15D	3.00	0.20	15.0	-	●	●	●	●		0.04-0.12
TAG R3J-15D	3.00	0.20	-	15.0	●	●	●	●		0.04-0.12
TAG L3JS-15D (1)	3.00	0.02	15.0	-	●		●			0.03-0.08
TAG R3JS-15D (1)	3.00	0.02	-	15.0	●		●			0.03-0.08
TAG L4J-4D	4.00	0.24	4.0	-	●		●			0.04-0.15
TAG R4J-4D	4.00	0.24	-	4.0	●	●	●	●		0.04-0.15
TAG L5J-4D	5.05	0.25	4.0	-	●		●			0.05-0.18
TAG R5J-4D	5.05	0.25	-	4.0	●		●			0.05-0.18
TAG L6.3J-4D	6.35	0.35	4.0	-	●		●			0.05-0.20
TAG R6.3J-4D	6.35	0.35	-	4.0	●		●			0.05-0.20

• For cutting speed recommendations and user guide, see pages 484-492

(1) Sharp corners cannot be used on TGSF slitting cutters

For tools, see pages: ADMP D45 (472) • TAGPAD-JHP (456) • TAGPAD-XL-JHP (456) • TGAD (455) • TGAD RE/LE-JHP (455) • TGBHR/L (316) • TGFH-JHP (451) • TGFH-MB (454) • TGFH-S (451) • TGFH/R/L (318) • TGFHL-TR (462) • TGFHR/L (452) • TGFHR/L-JHP (452) • TGFS (459) • TGSU (417) • TGTR/L-2T.SH-L120 (461) • TGTR/L-D (462) • TGTR/L-IQ (459) • TGTR/L-IQ-2Z (460) • TGTR/L-JHP (460) • TGTR/L-JHP-MC (461)

TANG-GRIP
 PARTING LINE

TAG N-LF

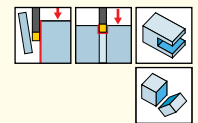
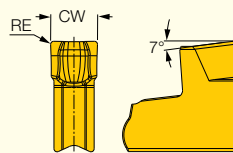
 Single-Ended Inserts for
 Parting, Grooving and
 Slitting Stainless Steel

Designation	Dimensions				Tough ↔ Hard					Recommended Machining Data
	CW	RE	CWTOL ⁽¹⁾	RETOL ⁽²⁾	IC830	IC1030	IC5400	IC1010	IC808	
TAG N2LF	2.00	0.20	0.04	0.030	●	●	●	●	●	0.03-0.08
TAG N3LF	3.00	0.20	0.04	0.030	●	●	●	●	●	0.04-0.10

• For cutting speed recommendations and user guide, see pages 484-492

(1) Cutting width tolerance (+/-)

(2) Corner radius tolerance (+/-)

For tools, see pages: ADMP D45 (472) • TAGPAD-JHP (456) • TAGPAD-XL-JHP (456) • TGAD (455) • TGAD RE/LE-JHP (455) • TGFH-JHP (451) • TGFH-MB (454) • TGFH-S (451) • TGFH/R/L (318) • TGFHL-TR (462) • TGFHR/L (452) • TGFHR/L-JHP (452) • TGFS (459) • TGTR/L-2T.SH-L120 (461) • TGTR/L-D (462) • TGTR/L-IQ (459) • TGTR/L-IQ-2Z (460) • TGTR/L-JHP-MC (461)

TAG N-UT

Single-Sided Inserts for Parting, Grooving & Slitting at Low Feeds on Cr-Ni Alloys, Ductile Materials & Low Carbon Steel

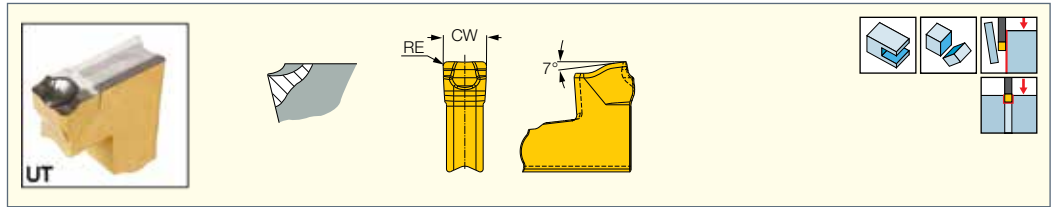

Designation	Dimensions				Tough ↔ Hard			Recommended Machining Data
	CW	RE	CWTOL ⁽¹⁾	RETOL ⁽²⁾	IC830	IC808	IC908	f groove (mm/rev)
TAG N2UT	2.00	0.20	0.04	0.040	●	●	●	0.03-0.10
TAG N3UT	3.00	0.30	0.04	0.040	●	●	●	0.04-0.12
TAG N4UT	4.00	0.30	0.04	0.040			●	0.05-0.15
TAG N5UT	5.00	0.30	0.04	0.040			●	0.05-0.18
TAG N6UT	6.00	0.85	0.04	0.040			●	0.06-0.22

• For cutting speed recommendations and user guide, see pages 484-492

⁽¹⁾ Cutting width tolerance (+/-)

⁽²⁾ Corner radius tolerance (+/-)

For tools, see pages: ADMP D45 (472) • TAGPAD-JHP (456) • TAGPAD-XL-JHP (456) • TGAD (455) • TGAD RE/LE-JHP (455) • TGBHR/L (316) • TGFH-JHP (451) • TGFH-MB (454) • TGFH-S (451) • TGFH/R/L (318) • TGFHL-TR (462) • TGFHR/L (452) • TGFHR/L-JHP (452) • TGFS (459) • TGTR/L-2T..SH-L120 (461) • TGTR/L-D (462) • TGTR/L-IQ (459) • TGTR/L-IQ-2Z (460) • TGTR/L-JHP-MC (461)

TAG N-A

Single-Ended Inserts for Parting, Grooving and Slitting Aluminum

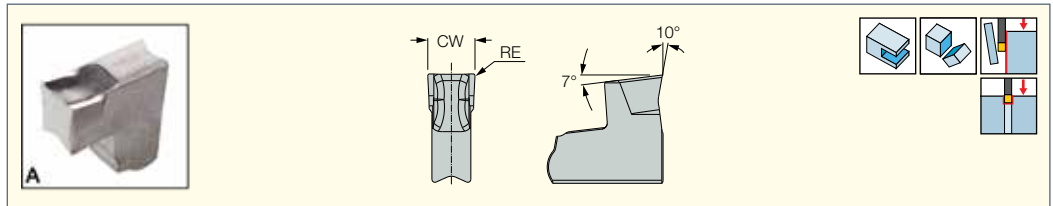

Designation	Dimensions				IC20	Recommended Machining Data
	CW	RE	CWTOL ⁽¹⁾	RETOL ⁽²⁾		f groove (mm/rev)
TAG N2A	2.00	0.20	0.04	0.04	●	0.02-0.10
TAG N3A	3.00	0.20	0.04	0.04	●	0.03-0.14
TAG N4A	4.00	0.24	0.04	0.03	●	0.03-0.16

• For cutting speed recommendations and user guide, see pages 484-492

⁽¹⁾ Cutting width tolerance (+/-)

⁽²⁾ Corner radius tolerance (+/-)

For tools, see pages: ADMP D45 (472) • TAGPAD-JHP (456) • TAGPAD-XL-JHP (456) • TGAD (455) • TGAD RE/LE-JHP (455) • TGFH-JHP (451) • TGFH-MB (454) • TGFH-S (451) • TGFH/R/L (318) • TGFHL-TR (462) • TGFHR/L (452) • TGFHR/L-JHP (452) • TGFS (459) • TGTR/L-2T..SH-L120 (461) • TGTR/L-D (462) • TGTR/L-IQ (459) • TGTR/L-IQ-2Z (460) • TGTR/L-JHP-MC (461)



TGTBQ-JHP
 Tool Blocks for Parting and Grooving Square Blades
 TANG-F-GRIP & DO-F-GRIP for High Pressure Coolant

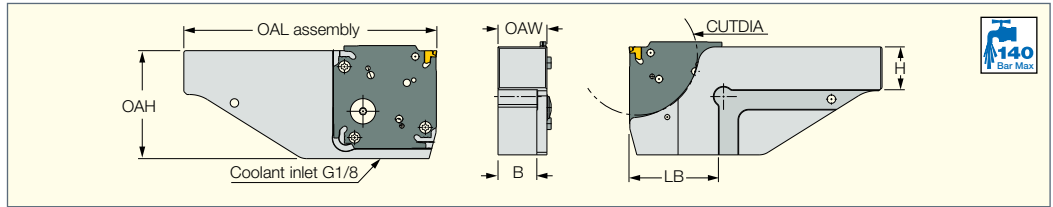

Designation	OAH	H	B	OAW	OAL	LB	CUTDIA
TGTBQ 20L-D52-JHP	50.0	20.0	20.5	26.50	122.00	34.00	52.0
TGTBQ 20R-D52-JHP	50.0	20.0	20.5	26.50	122.00	34.00	52.0
TGTBQ 25L-D52-JHP	50.0	25.0	25.5	31.50	132.00	34.00	52.0
TGTBQ 25R-D52-JHP	50.0	25.0	25.5	31.50	132.00	34.00	52.0
TGTBQ 20L-D82-JHP	64.0	20.0	20.5	26.50	140.00	53.00	82.0
TGTBQ 20R-D82-JHP	64.0	20.0	20.5	26.50	140.00	53.00	82.0
TGTBQ 25L-D82-JHP	64.0	25.0	25.5	31.50	150.00	53.00	82.0
TGTBQ 25R-D82-JHP	64.0	25.0	25.5	31.50	150.00	53.00	82.0
TGTBQ 32L-D82-JHP	64.0	32.0	32.5	38.50	150.50	53.50	82.0
TGTBQ 32R-D82-JHP	64.0	32.0	32.5	38.50	150.50	53.50	82.0
TGTBQ 25L-D120-JHP	95.0	25.0	25.5	31.50	165.00	67.00	120.0
TGTBQ 25R-D120-JHP	95.0	25.0	25.5	31.50	165.00	67.00	120.0
TGTBQ 32L-D120-JHP	95.0	32.0	32.5	38.50	165.00	67.00	120.0
TGTBQ 32R-D120-JHP	95.0	32.0	32.5	38.50	165.00	67.00	120.0

Table determining depth of cut for grooving as function of workpiece diameter

Designation	CUTDIA																	
	53	54	55	56	57	59	61	64	67	71	75	81	88	96	107	122	141	169
TGTBQ...D52-JHP	107	110	114	119	124	130	137	145	154	165	178	194	213	237	267	308	363	443
TGTBQ...D82-JHP	202	210	219	229	240	253	267	283	302	324	349	380	417	462	518	592	689	827
CDX	21	20	19	18	17	16	15	14	13	12	11	10	9	8	7	6	5	4

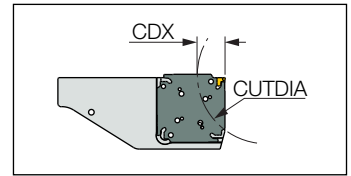

Designation	CUTDIA															
	83	83	84	84	85	86	87	88	89	91	92	94	96	98	101	103
TGTBQ...D82-JHP	139	141	143	145	148	150	153	156	160	164	168	172	177	183	188	195
TGTBQ...D120-JHP	37	36	35	34	33	32	31	30	29	28	27	26	25	24	23	22

Designation	CUTDIA																
	121	122	123	123	124	125	125	126	127	128	129	130	131	132	134	135	137
TGTBQ...D120-JHP	56-60	53-55	52	51	50	49	48	47	46	45	44	43	42	41	40	39	38

1. Block: TGTBQ...D...
2. Blade: T/DGAQ...
3. Locating Pin: Side thrust Pin 3mm
4. Screw: SR M4x10 ISO 14580
5. Screw: SR M4x9-Seal-JHP
6. Seal washer: CSW 1/8"
7. O-ring: O-ring 10x2 NBR

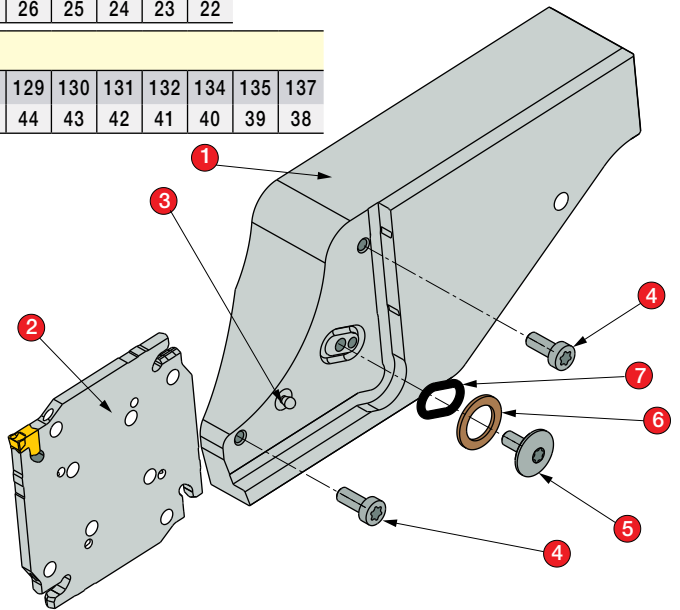

Spare Parts

Designation					
TGTBQ-JHP	SR M4X9-SEAL-JHP	T-20/5	SIDE THRUST PIN 3mm	JHP COPPER SEAL 1/8"	SR ISO 14580 M4X10

TGAQ-JHP

Parting and Grooving Square
Blades for TANG-GRIP
Tangentially Clamped Inserts

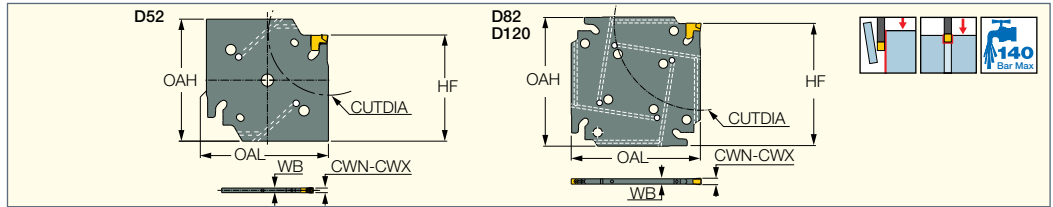



Designation	OAL	OAH	CWN ⁽¹⁾	CWX ⁽²⁾	WB	HF	CUTDIA
TGAQ D52-2-2Z-JHP	50.00	50.0	1.80	2.50	1.65	43.5	52.0
TGAQ D52-3-2Z-JHP	50.00	50.0	2.80	3.50	2.50	43.5	52.0
TGAQ D52-4-2Z-JHP	50.00	50.0	3.70	4.50	3.40	43.5	52.0
TGAQ D82-2-4Z-JHP	61.00	61.0	1.80	2.50	1.65	58.0	82.0
TGAQ D82-3-4Z-JHP	61.00	61.0	2.80	3.50	2.50	58.0	82.0
TGAQ D82-4-4Z-JHP	61.00	61.0	3.70	4.50	3.40	58.0	82.0
TGAQ D120-3-4Z-JHP	90.50	90.5	2.80	3.50	2.50	84.0	120.0
TGAQ D120-4-4Z-JHP	90.50	90.5	3.70	4.50	3.40	84.0	120.0
TGAQ D120-5-4Z-JHP	90.50	90.5	4.70	5.50	4.00	84.0	120.0

⁽¹⁾ Minimum cutting width
⁽²⁾ Maximum cutting width

Flow Rate vs. Pressure

Designation	70 Bar Flow Rate (liters/min)	100 Bar Flow Rate (liters/min)	140 Bar Flow Rate (liters/min)
TGAQ D52/82/-2...-JHP	4-7	5-8	6-9
TGAQ D52/82/120-3...-JHP			
TGAQ D52/82/120-4...-JHP	6-7	7-8	8-9
TGAQ D120-5-JHP			

Spare Parts

Designation			
TGAQ D52-2-2Z-JHP	SR M4X9-SEAL-JHP	JHP COPPER SEAL 1/8"	ETG 2*
TGAQ D52-3-2Z-JHP	SR M4X9-SEAL-JHP	JHP COPPER SEAL 1/8"	ETG 3-4-SH*
TGAQ D52-4-2Z-JHP	SR M4X9-SEAL-JHP	JHP COPPER SEAL 1/8"	ETG 3-4-SH*
TGAQ D82-2-4Z-JHP	SR M4X9-SEAL-JHP	JHP COPPER SEAL 1/8"	ETG 2*
TGAQ D82-3-4Z-JHP	SR M4X9-SEAL-JHP	JHP COPPER SEAL 1/8"	ETG 3-4-SH*
TGAQ D82-4-4Z-JHP	SR M4X9-SEAL-JHP	JHP COPPER SEAL 1/8"	ETG 3-4-SH*
TGAQ D120-3-4Z-JHP	SR M4X9-SEAL-JHP	JHP COPPER SEAL 1/8"	ETG 3-4-SH*
TGAQ D120-4-4Z-JHP	SR M4X9-SEAL-JHP	JHP COPPER SEAL 1/8"	ETG 3-4-SH
TGAQ D120-5-4Z-JHP	SR M4X9-SEAL-JHP	JHP COPPER SEAL 1/8"	ETG 5-7*

* Optional, should be ordered separately





DGAQ-JHP

Parting and Grooving Square
Blades for DO-GRIP Inserts

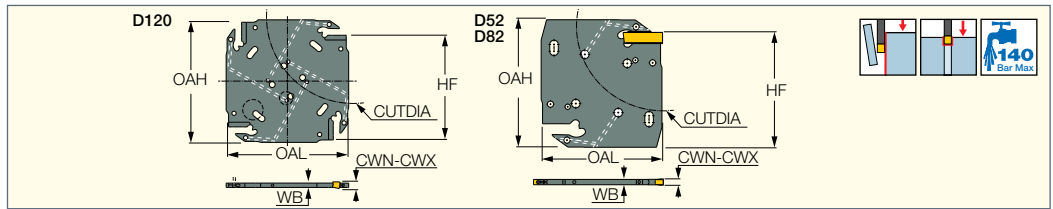

Designation	OAL	OAH	CWN ⁽¹⁾	CWX ⁽²⁾	WB	HF	CUTDIA
DGAQ D52-2-2Z-JHP	50.00	50.0	1.90	2.50	1.72	43.5	52.0
DGAQ D52-3-2Z-JHP	50.00	50.0	3.00	3.18	2.50	43.5	52.0
DGAQ D52-4-2Z-JHP	50.00	50.0	4.00	4.00	3.20	43.5	52.0
DGAQ D82-3-2Z-JHP	61.00	64.4	3.00	3.18	2.50	58.0	82.0
DGAQ D82-4-2Z-JHP	61.00	64.4	4.00	4.00	3.20	58.0	82.0
DGAQ D82-5-2Z-JHP	61.00	64.4	5.00	5.00	4.00	58.0	82.0
DGAQ D120-4-4Z-JHP	90.50	90.5	4.00	4.00	3.20	84.0	120.0
DGAQ D120-5-4Z-JHP	90.50	90.5	5.00	5.00	4.00	84.0	120.0

• When using 2 and 3mm double-sided inserts, the depth of cut is limited up to 19mm. For larger depth, use a DGNM type single-ended insert.

- ⁽¹⁾ Minimum cutting width
- ⁽²⁾ Maximum cutting width

Flow Rate vs. Pressure

Designation	70 Bar Flow Rate (liters/min)	100 Bar Flow Rate (liters/min)	140 Bar Flow Rate (liters/min)
DGAQ D52-2-2Z-JHP	4-7	5-8	6-9
DGAQ D52/82-3-2Z-JHP			
DGAQ D52/82/120-4-...-JHP	6-7	7-8	8-9
DGAQ D82/120-5-...-JHP			

Spare Parts

Designation			
DGAQ D52-2-2Z-JHP	SR M4X9-SEAL-JHP	JHP COPPER SEAL 1/8"	EDG 33A
DGAQ D52-3-2Z-JHP	SR M4X9-SEAL-JHP	JHP COPPER SEAL 1/8"	EDG 33A
DGAQ D52-4-2Z-JHP	SR M4X9-SEAL-JHP	JHP COPPER SEAL 1/8"	EDG 33A*
DGAQ D82-3-2Z-JHP	SR M4X9-SEAL-JHP	JHP COPPER SEAL 1/8"	EDG 33A*
DGAQ D82-4-2Z-JHP	SR M4X9-SEAL-JHP	JHP COPPER SEAL 1/8"	EDG 33A*
DGAQ D82-5-2Z-JHP	SR M4X9-SEAL-JHP	JHP COPPER SEAL 1/8"	EDG 33A*
DGAQ D120-4-4Z-JHP	SR M4X9-SEAL-JHP	JHP COPPER SEAL 1/8"	EDG 33A*
DGAQ D120-5-4Z-JHP	SR M4X9-SEAL-JHP	JHP COPPER SEAL 1/8"	EDG 33A*

* Optional, should be ordered separately



THMPR/L D22-JHP
Holders with High Pressure
Coolant Channels for Pentagonal
SELF-GRIP Adapters

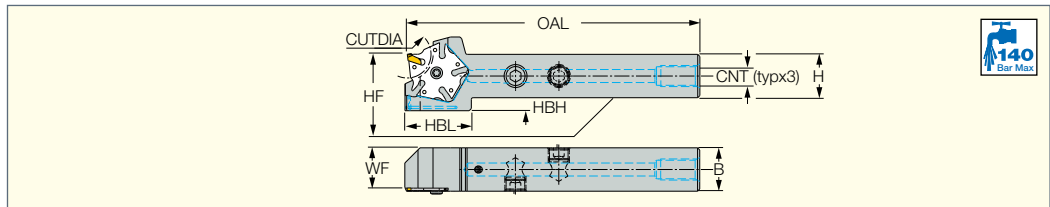

Designation	H	HF	HBH	B	WF	CUTDIA	OAL	HBL	CNT
THMPR/L 16-D22-JHP	16.0	16.1	10.0	16.0	14.60	22.0	135.00	29.6	UNF 5/16-24
THMPR/L 20-D22-JHP	20.0	20.1	6.0	20.0	18.60	22.0	135.00	29.6	G1/8

For tools, see pages: ADMP D22 (471)

THMPR/L...-D22-JHP CDX to CUTDIA

CDX	≤2.0	≤3.0	≤4.0	≤5.0	≤6.0	≤7.0	≤8.0	≤11.0
CUTDIA	85	80	75	70	65	60	55	50

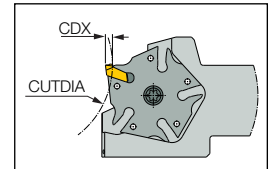

Spare Parts

Designation				
THMPR 16-D22-JHP	SR 5/16UNF TL360	HW 5/32"	SR M4X8 DIN912	HW 3.0
THMPL 20-D22-JHP	PLUG G1/8-6.5 TL360	HW 5.0	SR M4-39432	T-15/5
THMPR 20-D22-JHP	PLUG G1/8-6.5 TL360	HW 5.0	SR M4-39432	T-15/5

ADMP D22
Parting and Grooving
Adapters With 5 Pockets
for SELF-GRIP Inserts

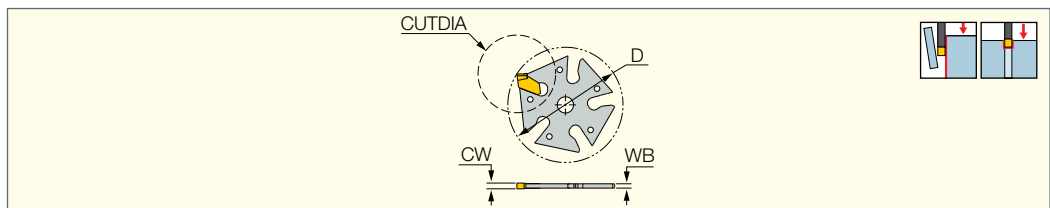

Designation	CW	WB	D	CUTDIA	Insert
ADMP D22-1.2	1.20	1.06	32	22.0	GFT 1.2
ADMP D22-1.6	1.60	1.20	32	22.0	GFT 1.6

• For user guide, see pages 484-492

For holders, see pages: THMPR/L D22-JHP (471)

Spare Parts

Designation	
ADMP D22	ESG-SLM*

* Optional, should be ordered separately

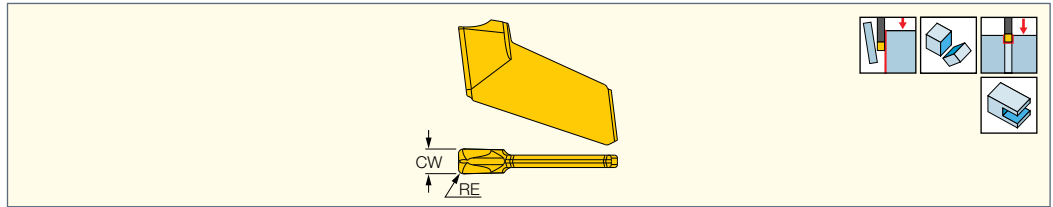

SLIMGRIP
NARROW INSERTS**GFT-J**Thin Parting, Grooving
& Slitting Single-Ended
Inserts for Soft Materials



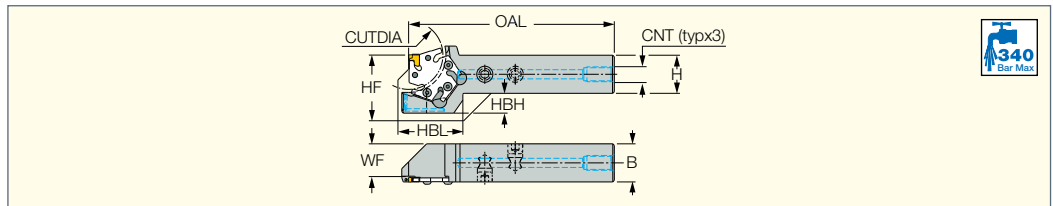

Designation	Dimensions		Tough ↔ Hard		Recommended Machining Data
	CW	RE	IC1028	IC1008	
GFT 0.8J-0.1	0.80	0.10	●	●	f groove (mm/rev) 0.03-0.08
GFT 1.0J-0.1	1.00	0.10	●	●	0.03-0.10
GFT 1.2J-0.14	1.20	0.14	●	●	0.03-0.10
GFT 1.6J-0.16	1.60	0.16	●	●	0.03-0.12

LOGIQ5GRIP
PARTING & GROOVING**JETCUT****THMPR/L D45-JHP**Holders with High Pressure
Coolant Channels for Pentagonal
TANG-GRIP Adapters

Designation	H	HF	HBH	B	WF	CUTDIA	OAL	HBL	CNT
THMPR/L 20-D45-JHP	20.0	20.1	18.0	20.0	17.35	45.0	135.00	35.6	G1/8
THMPR/L 25-D45-JHP	25.0	25.1	13.0	25.0	22.35	45.0	135.00	35.6	G1/8

For tools, see pages: ADMP D45 (472)

Spare Parts

Designation				
THMPR/L D45-JHP	SR M3X8 ISO 14580 BLACK	T-10/5 ^(a)	PLG 1/8BSP TL360	HW 5.0

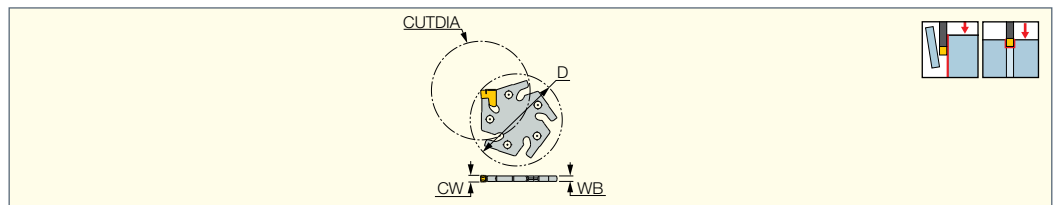
^(a) For optimal tightening torque, use SW4-FIX T10 optional torque limiting screwdriver.**LOGIQ5GRIP**
PARTING & GROOVING**TANG-GRIP**
PARTING LINE**ADMP D45**Parting and Grooving Adapters
With 5 Pockets for TANG-GRIP
Tangentially Clamped Inserts

Designation	CWN ⁽¹⁾	CWX ⁽²⁾	WB	D	CUTDIA	Insert
ADMP D45-2.0	1.80	2.40	1.60	42	45.0	TAG 2
ADMP D45-3.0	2.80	3.50	2.50	42	45.0	TAG 3

• For user guide, see pages 484-492

⁽¹⁾ Minimum cutting width⁽²⁾ Maximum cutting width

For inserts, see pages: TAG N-A (467) • TAG N-C/W/M (463) • TAG N-HF (463) • TAG N-J/JS/JT (465) • TAG N-LF (466) • TAG N-MF (464) • TAG N-UT (467) • TAG R/L-C (464) • TAG R/L-J/JS (466)

For holders, see pages: THMPR/L D45-JHP (472)

THMPR/L...-D45-JHP Tmax. to Dmax.									
Tmax	T≤3.0	T≤4.0	T≤5.0	T≤6.0	T≤7.0	T≤8.0	T≤9.0	T≤10.0	T≤22.5
Dmax	85	80	75	70	65	60	55	50	45

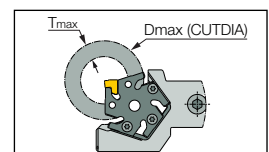

Spare Parts

Designation	
ADMP D45-2.0	ETG 2*
ADMP D45-3.0	ETG 3-4-SH*

* Optional, should be ordered separately

CUTGRIP

GIM-C

Parting and Grooving Single-Sided Inserts for Parting Bars, Hard Materials and Tough Applications

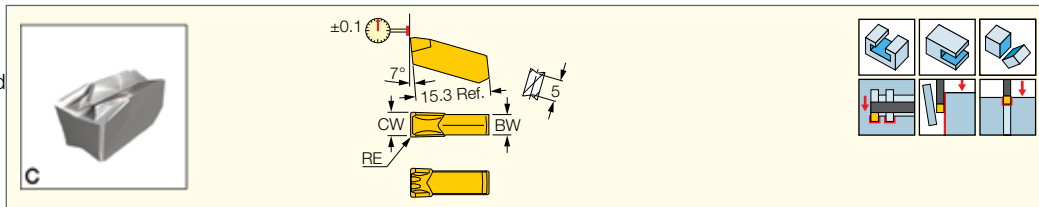

Designation	Dimensions				Tough ↔ Hard					Recommended Machining Data f groove (mm/rev)
	CW	RE	CWTOL ⁽¹⁾	BW	IC328	IC830	IC354	IC908	IC20	
GIM 3C	3.00	0.22	0.05	2.40	●	●	●	●	●	0.15-0.25
GIM 4C	4.00	0.25	0.05	3.40				●	●	0.15-0.25
GIM 5C	5.00	0.40	0.05	4.00	●	●	●	●	●	0.15-0.30
GIM 6C	6.00	0.40	0.05	4.80	●		●	●	●	0.15-0.30

• For cutting speed recommendations and user guide, see pages 484-492

⁽¹⁾ Cutting width tolerance (+/-)

For tools, see pages: Anti-Vibration Blades (268) • C#-GHDR/L (259) • CGHN 26-M (340) • CGHN 32-DGM (342) • CGHN 32-M (341) • CGHN-D (266) • CGHN-DG (267) • CGHN-S (266) • CGPAD (265) • CGPAD-JHP (265) • GHDR/L (short pocket) (259) • GHDR/L-JHP (short pocket) (260) • GHDR/L-JHP-MC (short pocket) (261) • GHGR/L (262) • GHMPR/L (258) • GHMR/L (258)

CUTGRIP

GIM-J

Utility Single-Sided Inserts for Parting and Grooving Soft Materials, Tubes and Small Diameters

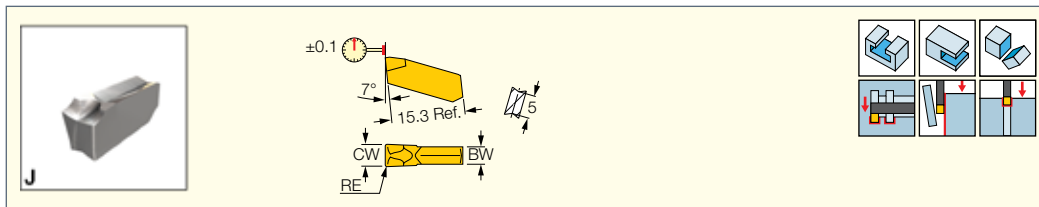

Designation	Dimensions				Tough ↔ Hard						Recommended Machining Data f groove (mm/rev)
	CW	RE	CWTOL ⁽¹⁾	BW	IC656	IC328	IC830	IC354	IC908	IC20	
GIM 2.2J	2.20	0.17	0.05	1.70		●	●	●	●	●	0.06-0.13
GIM 3J	3.00	0.25	0.05	2.40	●	●	●	●	●	●	0.08-0.15
GIM 4J	4.00	0.25	0.05	3.20		●	●	●	●	●	0.08-0.18

• For cutting speed recommendations and user guide, see pages 484-492

⁽¹⁾ Cutting width tolerance (+/-)

For tools, see pages: C#-GHDR/L (259) • CGHN 26-M (340) • CGHN 32-DGM (342) • CGHN 32-M (341) • CGHN-D (266) • CGHN-DG (267) • CGHN-S (266) • CGPAD (265) • CGPAD-JHP (265) • GHDR/L (short pocket) (259) • GHDR/L-JHP (short pocket) (260) • GHDR/L-JHP-MC (short pocket) (261) • GHGR/L (262) • GHMPR/L (258) • GHMR/L (258) • GHSL/L (357) • GHSL/L-JHP-SL (358)



CUTGRIP**GIM-J-RA/LA**

Utility Single-Sided Inserts
for Parting and Grooving
Soft Materials, Parting Tubes
and Small Diameters

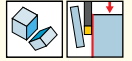
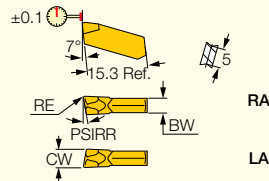

Designation	Dimensions						Tough ↔ Hard						Recommended Machining Data f groove (mm/rev)
	CW	RE	CWTOL ⁽¹⁾	PSIRL	PSIRR	BW	IC656	IC328	IC830	IC354	IC908	IC20	
GIM 2.2J-8LA	2.20	0.17	0.05	8.0	-	1.70		●		●	●	●	0.05-0.10
GIM 2.2J-8RA	2.20	0.17	0.05	-	8.0	1.70	●	●	●	●	●	●	0.05-0.10
GIM 2.2JS-15LA	2.20	0.02	0.05	15.0	-	1.70		●		●	●	●	0.05-0.10
GIM 2.2JS-15RA	2.20	0.02	0.05	-	15.0	1.70	●	●	●	●	●	●	0.05-0.10
GIM 3J-4LA	3.00	0.22	0.05	4.0	-	2.40				●		●	0.05-0.12
GIM 3J-4RA	3.00	0.25	0.05	-	4.0	2.40		●	●	●		●	0.05-0.12
GIM 3J-8LA	3.00	0.25	0.05	8.0	-	2.40		●		●	●	●	0.05-0.12
GIM 3J-8RA	3.00	0.25	0.05	-	8.0	2.40	●	●	●	●	●	●	0.05-0.12
GIM 3JS-15LA	3.00	0.02	0.05	15.0	-	2.40		●	●		●	●	0.05-0.12
GIM 3JS-15RA	3.00	0.02	0.05	-	15.0	2.40	●	●		●	●	●	0.05-0.12
GIM 4J-6LA	4.00	0.25	0.05	6.0	-	3.20						●	0.08-0.15
GIM 4J-6RA	4.00	0.25	0.05	-	6.0	3.20				●		●	0.08-0.15

• For cutting speed recommendations and user guide, see pages 484-492

⁽¹⁾ Cutting width tolerance (+/-)

For tools, see pages: C#-GHDR/L (259) • CGHN 26-M (340) • CGHN 32-DGM (342) • CGHN 32-M (341) • CGHN-D (266) • CGHN-DG (267) • CGHN-S (266) • CGPAD (265) • CGPAD-JHP (265) • GHDR/L (short pocket) (259) • GHDR/L-JHP (short pocket) (260) • GHDR/L-JHP-MC (short pocket) (261) • GHGR/L (262) • GHMPR/L (258) • GHMR/L (258) • GHSR/L (357) • GHSR/L-JHP-SL (358)

CUTGRIP**GIM-W**

Single-Sided Inserts with
Central Ridged Chipformer and
Reinforced Edge for Parting
and Grooving Alloy Steel

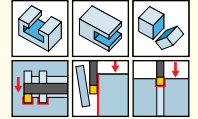
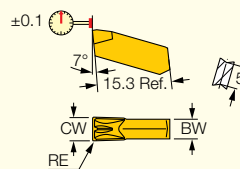

Designation	Dimensions				Tough ↔ Hard						Recommended Machining Data f groove (mm/rev)
	CW	RE	CWTOL ⁽¹⁾	BW	IC656	IC328	IC830	IC354	IC908	IC20	
GIM 2.4	2.40	0.18	0.05	2.40				●	●	●	0.10-0.18
GIM 3	3.00	0.22	0.05	2.40		●	●	●	●	●	0.10-0.18
GIM 3.2	3.20	0.22	0.05	2.40	●	●	●	●	●	●	0.10-0.20
GIM 4	4.00	0.25	0.05	3.20	●	●	●	●	●	●	0.15-0.20

• For cutting speed recommendations and user guide, see pages 484-492

⁽¹⁾ Cutting width tolerance (+/-)

For tools, see pages: C#-GHDR/L (259) • CGHN 26-M (340) • CGHN 32-DGM (342) • CGHN 32-M (341) • CGHN-D (266) • CGHN-DG (267) • CGHN-S (266) • CGPAD (265) • CGPAD-JHP (265) • GHDR/L (short pocket) (259) • GHDR/L-JHP (short pocket) (260) • GHDR/L-JHP-MC (short pocket) (261) • GHGR/L (262) • GHMPR/L (258) • GHMR/L (258)

CUTGRIP**GDMW 2.4**

Utility Double-Ended
Inserts for External Turning,
Grooving and Parting

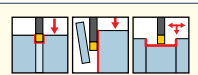
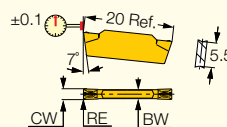

Designation	Dimensions						Tough ↔ Hard					Recommended Machining Data		
	CW	RE	CWTOL ⁽¹⁾	RETOL ⁽²⁾	BW	CDX ⁽³⁾	IC830	IC808	IC908	IC20	IC20N	a _p (mm)	f turn (mm/rev)	f groove (mm/rev)
GDMW 2.4	2.40	0.18	0.04	0.030	2.00	18.00	●	●	●	●	●	0.25-1.50	0.07-0.12	0.05-0.08

• For cutting speed recommendations and user guide, see pages 484-492

⁽¹⁾ Cutting width tolerance (+/-)

⁽²⁾ Corner radius tolerance (+/-)

⁽³⁾ Cutting depth maximum

For tools, see pages: PADR/L (294) • PHGR/L (293) • PHSR/L (357)

CUTGRIP**GIM-W-RA/LA**

Single-Sided Screw-Clamped Inserts with Central Ridged Chipformer for Parting Alloy Steel

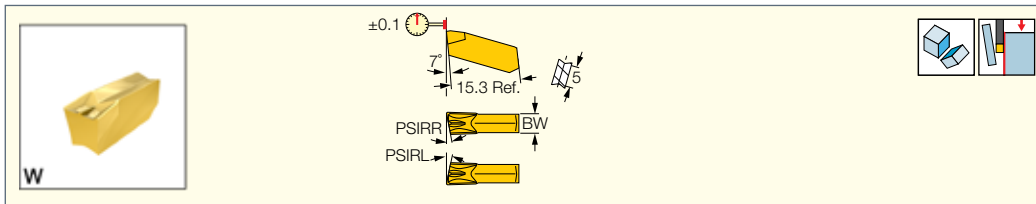

Designation	Dimensions						Tough ↔ Hard						Recommended Machining Data f groove (mm/rev)	
	CW	RE	CWTOL ⁽¹⁾	PSIRL	PSIRR	BW	IC656	IC328	IC830	IC354	IC908	IC20		
GIM 3-4LA	3.00	0.20	0.05	4.0	-	2.40		●					●	0.08-0.16
GIM 3-4RA	3.00	0.25	0.05	-	4.0	2.40	●		●				●	0.08-0.16
GIM 3-8LA	3.00	0.20	0.05	8.0	-	2.40		●					●	0.08-0.16
GIM 3-8RA	3.00	0.25	0.05	-	8.0	2.40	●		●				●	0.08-0.16
GIM 3S-15RA	3.00	0.22	0.05	-	15.0	2.40		●						0.08-0.16
GIM 3.2-4LA	3.20	0.22	0.05	4.0	-	2.50				●				0.08-0.16
GIM 3.2-4RA	3.20	0.22	0.05	-	4.0	2.50		●		●			●	0.08-0.16
GIM 3.2-8LA	3.20	0.22	0.05	8.0	-	2.50				●				0.08-0.16
GIM 3.2-8RA	3.20	0.22	0.05	-	8.0	2.50		●		●	●		●	0.08-0.16
GIM 4-4LA	4.00	0.25	0.05	4.0	-	3.20				●				0.10-0.16
GIM 4-4RA	4.00	0.25	0.05	-	4.0	3.20	●			●	●		●	0.10-0.16
GIM 4-8LA	4.00	0.25	0.05	8.0	-	3.20				●				0.10-0.16
GIM 4-8RA	4.00	0.25	0.05	-	8.0	3.20		●		●	●		●	0.10-0.16

• For cutting speed recommendations and user guide, see pages 484-492

⁽¹⁾ Cutting width tolerance (+/-)

For tools, see pages: C#-GHDR/L (259) • CGHN 26-M (340) • CGHN 32-DGM (342) • CGHN 32-M (341) • CGHN-D (266) • CGHN-DG (267) • CGHN-S (266) • CGPAD (265) • CGPAD-JHP (265) • GHDR/L (short pocket) (259) • GHDR/L-JHP (short pocket) (260) • GHDR/L-JHP-MC (short pocket) (261) • GHGR/L (262) • GHMPR/L (258) • GHMR/L (258)

CUTGRIP**GIM-UT**

Single-Ended Screw-Clamped Inserts for Parting and Grooving at Low Feeds on CrNi Alloys and Low Carbon Steel

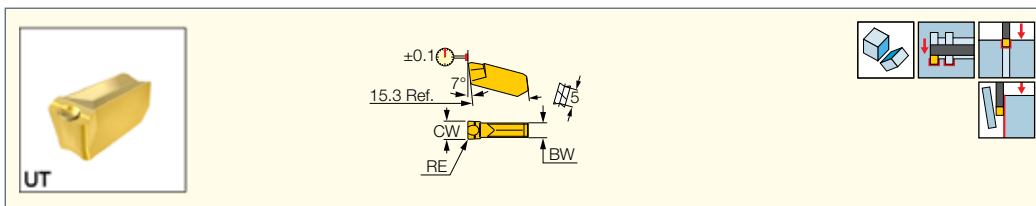

Designation	Dimensions				Tough ↔ Hard		Recommended Machining Data f groove (mm/rev)
	CW	RE	CWTOL ⁽¹⁾	BW	IC656	IC328	
GIM 4.6UT	4.60	0.60	0.03	3.80	●	●	0.03-0.10

• For cutting speed recommendations and user guide, see pages 484-492

⁽¹⁾ Cutting width tolerance (+/-)

For tools, see pages: C#-GHDR/L (259) • CGHN 26-M (340) • CGHN 32-DGM (342) • CGHN 32-M (341) • CGHN-D (266) • CGHN-DG (267) • CGHN-S (266) • CGPAD (265) • CGPAD-JHP (265) • GHDR/L (short pocket) (259) • GHDR/L-JHP (short pocket) (260) • GHDR/L-JHP-MC (short pocket) (261) • GHGR/L (262) • GHMPR/L (258) • GHMR/L (258)

CUTGRIP**GIM-UT-RA/LA**

Single-Ended Screw-Clamped Inserts for Parting at Low Feeds on CrNi Alloys and Low Carbon Steel

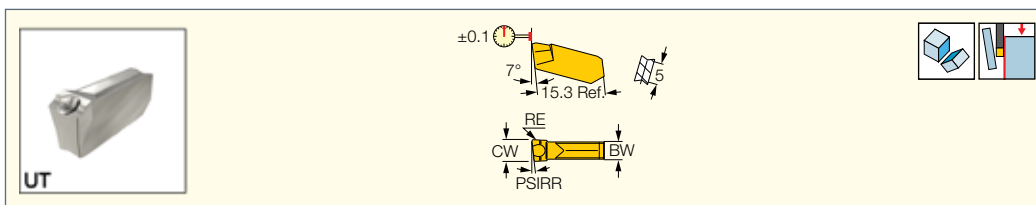

Designation	Dimensions						Recommended Machining Data f groove (mm/rev)	
	CW	RE	CWTOL ⁽¹⁾	PSIRL	PSIRR	BW		IC328
GIM 3UT-1.5RA	3.12	0.25	0.03	-	1.5	2.50	●	0.03-0.10

• For cutting speed recommendations and user guide, see pages 484-492

⁽¹⁾ Cutting width tolerance (+/-)

For tools, see pages: C#-GHDR/L (259) • CGHN 26-M (340) • CGHN 32-DGM (342) • CGHN 32-M (341) • CGHN-D (266) • CGHN-DG (267) • CGHN-S (266) • CGPAD (265) • CGPAD-JHP (265) • GHDR/L (short pocket) (259) • GHDR/L-JHP (short pocket) (260) • GHDR/L-JHP-MC (short pocket) (261) • GHGR/L (262) • GHMPR/L (258) • GHMR/L (258)

PCHR/L-D-IQ

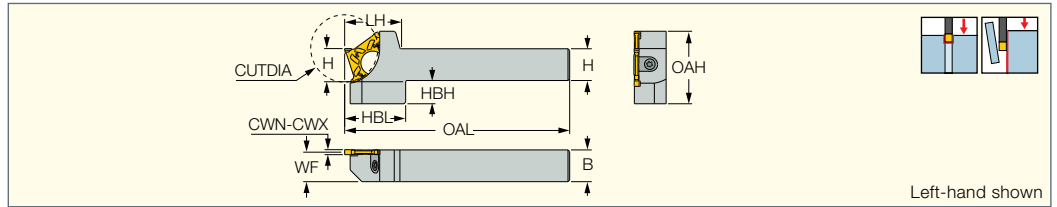
 Grooving and Parting
 Tools Carrying Inserts
 with 5 Cutting Edges

Designation	H	B	CWN ⁽¹⁾	CWX ⁽²⁾	WF	CUTDIA	OAL	LH	HBL	HBH	OAH
PCHR/L 12-D22-2-IQ	12.0	12.0	2.00	2.40	11.40	22.0	100.00	26.9	25.70	8.0	25.5
PCHR/L 16-D22-2-IQ	16.0	16.0	2.00	2.40	15.40	22.0	120.00	26.9	23.20	4.0	25.5
PCHR/L 20-D22-2-IQ	20.0	20.0	2.00	2.40	19.40	22.0	120.00	26.9	-	-	25.5
PCHR/L 12-D22-3-IQ	12.0	12.0	3.00	3.20	10.70	22.0	120.00	19.7	20.00	11.0	25.5
PCHR/L 16-D22-3-IQ	16.0	16.0	3.00	3.20	14.70	22.0	120.00	19.7	20.00	7.0	25.5
PCHR/L 20-D22-3-IQ	20.0	20.0	3.00	3.20	18.70	22.0	120.00	19.7	-	-	25.5
PCHR/L 12-D32-2-IQ	12.0	12.0	2.00	2.40	11.50	32.0	100.00	28.4	29.50	14.0	33.6
PCHR/L 16-D32-2-IQ	16.0	16.0	2.00	2.40	15.50	32.0	120.00	28.4	29.50	10.0	33.6
PCHR/L 20-D32-2-IQ	20.0	20.0	2.00	2.40	19.50	32.0	120.00	28.4	29.50	6.0	33.6
PCHR/L 25-D32-2-IQ	25.0	25.0	2.00	2.40	24.50	32.0	120.00	28.4	-	-	33.6
PCHR/L 12-D32-3-IQ	12.0	12.0	3.00	3.20	10.70	32.0	100.00	26.0	32.00	16.0	32.6
PCHR/L 16-D32-3-IQ	16.0	16.0	3.00	3.20	14.70	32.0	120.00	26.0	32.00	12.0	32.6
PCHR/L 20-D32-3-IQ	20.0	20.0	3.00	3.20	18.70	32.0	120.00	26.0	32.00	8.0	32.6
PCHR/L 25-D32-3-IQ	25.0	25.0	3.00	3.20	23.70	32.0	120.00	26.0	-	-	32.6
PCHR/L 16-D40-3-IQ	16.0	16.0	3.00	3.20	14.70	40.0	135.00	33.3	36.80	17.0	43.5
PCHR/L 20-D40-3-IQ	20.0	20.0	3.00	3.20	18.70	40.0	135.00	33.3	35.60	13.0	43.5
PCHR/L 25-D40-3-IQ	25.0	25.0	3.00	3.20	23.70	40.0	135.00	33.3	33.60	8.0	43.5
PCHR/L 32-D40-3-IQ	32.0	32.0	3.00	3.20	30.70	40.0	135.00	33.3	-	-	43.5

⁽¹⁾ Minimum cutting width

⁽²⁾ Maximum cutting width

For inserts, see pages: PENTA D-N-C (478) • PENTA D-N-J (478) • PENTA D-N-PB (479) • PENTA D-R/L-C (479) • PENTA D-R/L-J (478) • PENTA D-R/L-PB (479)

Tmax as a Function of Dmax for PENTA D22

Tmax	T _{≤1.2}	T _{≤2.0}	T _{≤3.0}	T _{≤4.0}	T _{≤5.0}	T _{≤7.0}	T _{≤9.0}	T _{≤11.0}
Dmax	N.L. ⁽¹⁾	600	130	60	40	30	25	22

Tmax as a Function of Dmax for PENTA D32

Tmax	T _{≤1.2}	T _{≤2}	T _{≤3.0}	T _{≤4.0}	T _{≤5.0}	T _{≤6.0}	T _{≤7.0}	T _{≤8.0}	T _{≤9.0}	T _{≤16.0}
Dmax	N.L. ⁽¹⁾	N.L. ⁽¹⁾	250	130	80	60	50	45	40	32

Tmax as a Function of Dmax for PENTA D40

Tmax	T _{≤1.2}	T _{≤2}	T _{≤3.0}	T _{≤4.0}	T _{≤5.0}	T _{≤6.0}	T _{≤7.0}	T _{≤8.0}	T _{≤9.0}	T _{≤10.0}	T _{≤11.0}	T _{≤12.0}	T _{≤13.0}	T _{≤16.0}	T _{≤20.0}
Dmax	N.L. ⁽¹⁾	N.L. ⁽¹⁾	N.L. ⁽¹⁾	350	200	140	105	85	75	65	60	55	50	45	40

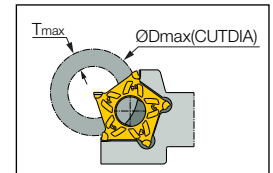
⁽¹⁾ N.L. = No Limit

Spare Parts

Designation				
PCHR/L 12-D22-2-IQ	SR M6-R-L	LEVER PD22-2 INJ	BLD T15/S7	SW6-SD
PCHR/L 16-D22-2-IQ	SR M6-R-L	LEVER PD22-2 INJ	BLD T15/S7	SW6-SD
PCHR/L 20-D22-2-IQ	SR M6-R-L	LEVER PD22-2 INJ	BLD T15/S7	SW6-SD
PCHR/L 12-D22-3-IQ	SR M6-R-L	LEVER PD22-3 INJ	BLD T15/S7	SW6-SD
PCHR/L 16-D22-3-IQ	SR M6-R-L	LEVER PD22-3 INJ	BLD T15/S7	SW6-SD
PCHR/L 20-D22-3-IQ	SR M6-R-L	LEVER PD22-3 INJ	BLD T15/S7	SW6-SD
PCHR/L 12-D32-2-IQ	SR M6-R-L	LEVER PD32-2 INJ	BLD T15/S7	SW6-SD
PCHR/L 16-D32-2-IQ	SR M6-R-L	LEVER PD32-2 INJ	BLD T15/S7	SW6-SD
PCHR/L 20-D32-2-IQ	SR M6-R-L	LEVER PD32-2 INJ	BLD T15/S7	SW6-SD
PCHR/L 25-D32-2-IQ	SR M6-R-L	LEVER PD32-2 INJ	BLD T15/S7	SW6-SD
PCHR/L 12-D32-3-IQ	SR M6-R-L	LEVER PD22-3 INJ	BLD T15/S7	SW6-SD
PCHR/L 16-D32-3-IQ	SR M6-R-L	LEVER PD32-3 INJ	BLD T15/S7	SW6-SD
PCHR/L 20-D32-3-IQ	SR M6-R-L	LEVER PD32-3 INJ	BLD T15/S7	SW6-SD
PCHR/L 25-D32-3-IQ	SR M6-R-L	LEVER PD32-3 INJ	BLD T15/S7	SW6-SD
PCHR/L 16-D40-3-IQ	SR M7-R-L	LEVER PD40 INJ	BLD T20/S7	SW6-SD
PCHR/L 20-D40-3-IQ	SR M7-R-L	LEVER PD40 INJ	BLD T20/S7	SW6-SD
PCHR/L 25-D40-3-IQ	SR M7-R-L	LEVER PD40 INJ	BLD T20/S7	SW6-SD
PCHR/L 32-D40-3-IQ	SR M7-R-L	LEVER PD40 INJ	BLD T20/S7	SW6-SD

PCHR/L-D-JHP

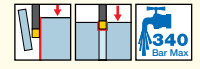
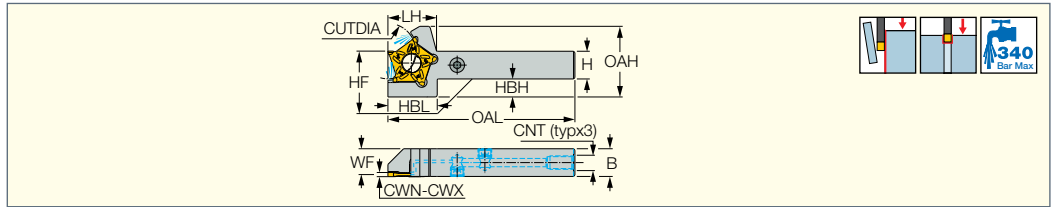
Grooving and Parting Tools
Carrying Inserts with 5 Cutting
Edges and Channels for
High Pressure Coolant



Designation	H	HF	HBH	B	CWN ⁽¹⁾	CWX ⁽²⁾	WF	CUTDIA	OAL	LH	HBL	OAH	CNT
PCHR/L 12-D22-2-JHP	12.0	0.0	8.0	12.0	2.00	2.40	11.00	22.0	101.50	29.0	29.50	32.0	UNF 5/16-24
PCHR/L 16-D22-2-JHP	16.0	0.0	4.0	16.0	2.00	2.40	15.00	22.0	121.50	29.0	29.50	32.0	UNF 5/16-24
PCHR/L 20-D22-2-JHP	20.0	0.0	-	20.0	2.00	2.40	19.00	22.0	121.50	29.0	29.50	32.0	G 1/8-28
PCHR/L 12-D32-2-JHP	12.0	12.1	14.5	12.0	2.00	2.40	11.15	32.0	100.00	30.5	31.00	41.0	UNF 5/16-24
PCHR/L 16-D32-2-JHP	16.0	16.1	10.0	16.0	2.00	2.40	15.21	32.0	120.00	25.9	27.00	41.0	UNF 5/16-24
PCHR/L 20-D32-2-JHP	20.0	20.1	6.5	20.0	2.00	2.40	18.40	32.0	120.00	30.5	31.00	41.0	G 1/8-28
PCHR/L 25-D32-2-JHP	25.0	25.1	1.5	25.0	2.00	2.40	23.40	32.0	120.00	29.0	29.50	41.0	G 1/8-28
PCHR/L 16-D40-3-JHP	16.0	16.0	17.0	16.0	3.00	3.20	14.60	40.0	135.00	36.3	36.80	51.0	UNF 5/16-24
PCHR/L 20-D40-3-JHP	20.0	20.0	13.0	20.0	3.00	3.20	18.60	40.0	135.00	35.1	35.60	51.0	G 1/8-28
PCHR/L 25-D40-3-JHP	25.0	25.0	8.0	25.0	3.00	3.20	23.60	40.0	135.00	33.1	33.60	51.0	G 1/8-28

⁽¹⁾ Minimum cutting width

⁽²⁾ Maximum cutting width

For inserts, see pages: PENTA D-N-C (478) • PENTA D-N-J (478) • PENTA D-N-PB (479) • PENTA D-R/L-C (479) • PENTA D-R/L-J (478) • PENTA D-R/L-PB (479)

PCHR/L D22-2...-JHP Dmax for Parting Off 22/T11										
Tmax	T≤1.0	T≤2.0	T≤3.0	T≤4.0	T≤5.0	T≤6.0	T≤7.0	T≤8.0	T≤9.0	T≤10.0
Dmax	89	64	48	40	34	31	28	27	24	21

PCHR/L D32-2...-JHP Dmax for Parting Off 32/T16										
Tmax	T≤1.0	T≤2.0	T≤3.0	T≤4.0	T≤5.0	T≤6.0	T≤7.0	T≤8.0	T≤9.0	T≤10.0
Dmax	150	125	100	78	65	57	51	46	43	40
Tmax	T≤11.0	T≤12.0	T≤13.0	T≤14.0	T≤15.0					
Dmax	39	37	35	34	33					

PCHR/L D40-3...-JHP Dmax for Parting Off 40/T20										
Tmax	T≤1.0	T≤2.0	T≤3.0	T≤4.0	T≤5.0	T≤6.0	T≤7.0	T≤8.0	T≤9.0	T≤10.0
Dmax	400	300	200	145	114	95	82	73	66	61
Tmax	T≤11.0	T≤12.0	T≤13.0	T≤14.0	T≤15.0	T≤16.0	T≤17.0	T≤18.0	T≤19.0	
Dmax	57	54	51	49	47	46	45	44	42	

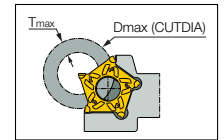

Flow Rate vs. Pressure

Designation	70 bar	100 bar	140 bar
	Flow Rate (liters/min)	Flow Rate (liters/min)	Flow Rate (liters/min)
PCHR/L....-2JHP	2-4	4-6	6-8
PCHR/L....-3JHP	7-9	9-11	11-13

Spare Parts

Designation							
PCHR/L 12-D22-2-JHP	SR M6-R-L	LEVER PD22-2 INJ	BLD T15/S7 ^(a)	SW6-SD	HW 5/32"		SR 5/16UNF TL360
PCHR/L 16-D22-2-JHP	SR M6-R-L	LEVER PD22-2 INJ	BLD T15/S7 ^(a)	SW6-SD	HW 5/32"		SR 5/16UNF TL360
PCHR/L 20-D22-2-JHP	SR M6-R-L	LEVER PD22-2 INJ	BLD T15/S7 ^(a)	SW6-SD	HW 5.0	PLG 1/8BSP TL360	
PCHR/L 12-D32-2-JHP	SR M6-R-L	LEVER PD32-2 INJ	BLD T15/S7 ^(a)	SW6-SD	HW 5/32"		SR 5/16UNF TL360
PCHR/L 16-D32-2-JHP	SR M6-R-L	LEVER PD32-2 INJ	BLD T15/S7 ^(a)	SW6-SD	HW 5/32"		SR 5/16UNF TL360
PCHR/L 20-D32-2-JHP	SR M6-R-L	LEVER PD32-2 INJ	BLD T15/S7 ^(a)	SW6-SD	HW 5.0	PLG 1/8BSP TL360	
PCHR/L 25-D32-2-JHP	SR M6-R-L	LEVER PD32-2 INJ	BLD T15/S7 ^(a)	SW6-SD	HW 5.0	PLG 1/8BSP TL360	
PCHR/L 16-D40-3-JHP	SR M7-R-L	LEVER PD40 INJ	BLD T20/S7 ^(b)	SW6-SD	HW 5/32"		SR 5/16UNF TL360
PCHR/L 20-D40-3-JHP	SR M7-R-L	LEVER PD40 INJ	BLD T20/S7 ^(b)	SW6-SD	HW 5.0	PLG 1/8BSP TL360	
PCHR/L 25-D40-3-JHP	SR M7-R-L	LEVER PD40 INJ	BLD T20/S7 ^(b)	SW6-SD	HW 5.0	PLG 1/8BSP TL360	

(a) For limiting torque, use optional BLD 4 T15-4.8NM blade & HSD 4-4.8NM handle.

(b) For limiting torque, use optional BLD 6 T20 blade & TSA 6 5-14 handle.

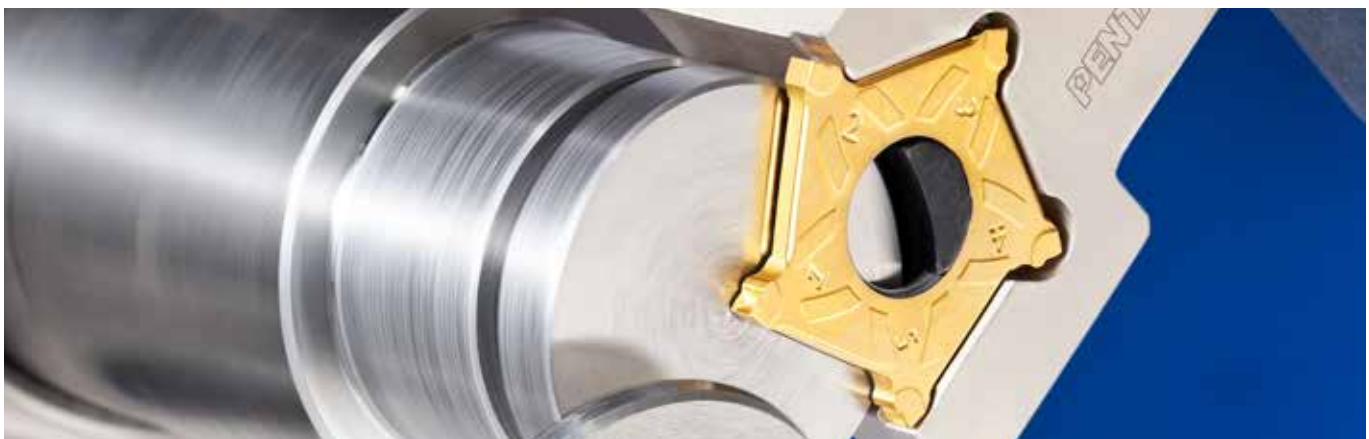

PENTA IQGRIP
PARTING LINE

PENTA D-N-J

Inserts with 5 Cutting Edges
for Parting and Grooving Soft
Materials, Parting Tubes, Small
and Thin-Walled Parts

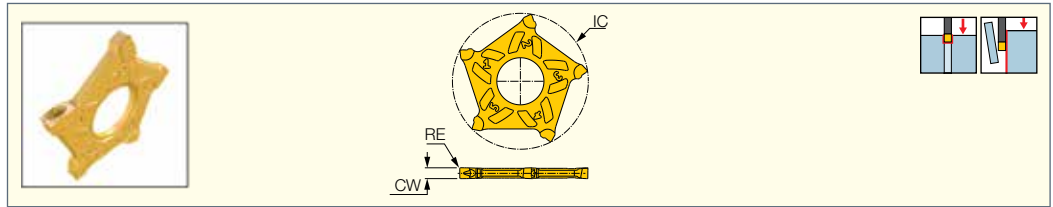

Designation	Dimensions					IC808G	Recommended Machining Data
	CW	RE	CWTOL ⁽¹⁾	RETOL ⁽²⁾	IC		f groove (mm/rev)
PENTA D22N200J020	2.00	0.20	0.02	0.03	22.00	●	0.04-0.12
PENTA D22N300J020	3.00	0.20	0.02	0.03	22.00	●	0.04-0.16

• For cutting speed recommendations and user guide, see pages 484-492

⁽¹⁾ Cutting width tolerance (+/-)

⁽²⁾ Corner radius tolerance (+/-)

For tools, see pages: PCHR/L-D-IQ (476) • PCHR/L-D-JHP (477)

PENTA IQGRIP
PARTING LINE

PENTA D-R/L-J

Inserts with 5 Cutting Edges
for Parting Tubes, Small
and Thin-Walled Parts

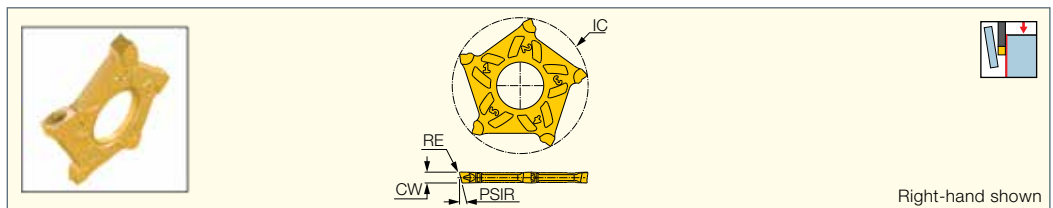

Designation	Dimensions					IC808G	Recommended Machining Data
	CW	RE	IC	PSIRL	PSIRR		f groove (mm/rev)
PENTA D22L200J-6D	2.00	0.20	22.00	6.0	-	●	0.04-0.10
PENTA D22R200J-6D	2.00	0.20	22.00	-	6.0	●	0.04-0.10
PENTA D22L200J-15D	2.00	0.20	22.00	15.0	-	●	0.04-0.08
PENTA D22R200J-15D	2.00	0.20	22.00	-	15.0	●	0.04-0.08
PENTA D22L300J-6D	3.00	0.20	22.00	6.0	-	●	0.04-0.12
PENTA D22R300J-6D	3.00	0.20	22.00	-	6.0	●	0.04-0.12
PENTA D22L300J-15D	3.00	0.20	22.00	15.0	-	●	0.04-0.10
PENTA D22R300J-15D	3.00	0.20	22.00	-	15.0	●	0.04-0.10

• For cutting speed recommendations and user guide, see pages 484-492

For tools, see pages: PCHR/L-D-IQ (476) • PCHR/L-D-JHP (477)

PENTA IQGRIP
PARTING LINE

PENTA D-N-C

Inserts with 5 Cutting Edges
for Parting and Grooving
Hard Materials, Tough and
General Applications

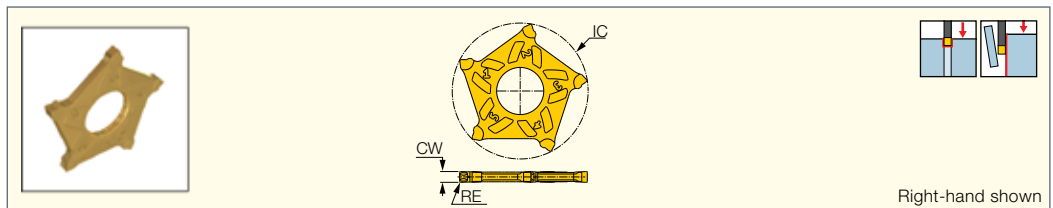

Designation	Dimensions					IC808G	Recommended Machining Data
	RE	CW	RETOL ⁽¹⁾	CWTOL ⁽²⁾	IC		f groove (mm/rev)
PENTA D32N200C020	0.20	2.00	0.030	0.02	30.25	●	0.04-0.14
PENTA D32N300C020	0.20	3.00	0.030	0.02	30.25	●	0.06-0.22
PENTA D40N300C020	0.20	3.02	0.030	0.02	37.80	●	0.06-0.22

• For cutting speed recommendations and user guide, see pages 484-492

⁽¹⁾ Corner radius tolerance (+/-)

⁽²⁾ Cutting width tolerance (+/-)

For tools, see pages: PCHR/L-D-IQ (476) • PCHR/L-D-JHP (477)

PENTA D-R/L-C

Inserts with 5 Cutting Edges for Parting Hard Materials, Tough and General Applications

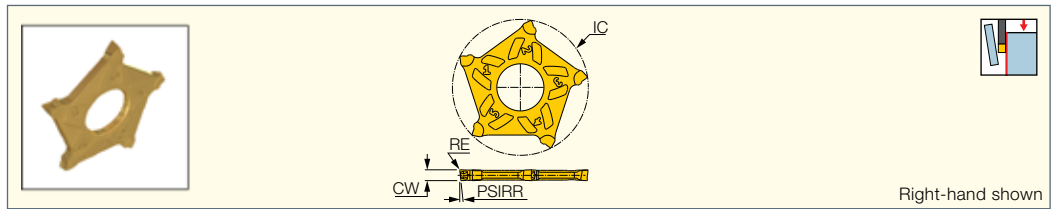

Designation	Dimensions					IC808G	Recommended Machining Data
	CW	RE	IC	PSIRL	PSIRR		f groove (mm/rev)
PENTA D32L200C-6D	2.00	0.10	30.25	6.0	-	●	0.04-0.12
PENTA D32R200C-6D	2.00	0.10	30.25	-	6.0	●	0.04-0.12
PENTA D32L200C-15D	2.00	0.20	30.25	15.0	-	●	0.04-0.10
PENTA D32R200C-15D	2.00	0.20	30.25	-	15.0	●	0.04-0.10
PENTA D32L300C-6D	3.00	0.20	30.25	6.0	-	●	0.04-0.14
PENTA D32R300C-6D	3.00	0.20	30.25	-	6.0	●	0.04-0.14
PENTA D32L300C-15D	3.00	0.20	30.25	15.0	-	●	0.04-0.10
PENTA D32R300C-15D	3.00	0.20	30.25	-	15.0	●	0.04-0.10
PENTA D40L300C-6D	3.00	0.20	37.80	6.0	-	●	0.04-0.14
PENTA D40R300C-6D	3.00	0.20	37.80	-	6.0	●	0.04-0.14
PENTA D40L300C-15D	3.00	0.20	37.80	15.0	-	●	0.04-0.10
PENTA D40R300C-15D	3.00	0.20	37.80	-	15.0	●	0.04-0.10

• For cutting speed recommendations and user guide, see pages 484-492
For tools, see pages: PCHR/L-D-IQ (476) • PCHR/L-D-JHP (477)

PENTA D-N-PB

Pentagonal Inserts for Parting and Grooving Bearing Steel and Other Ductile Materials

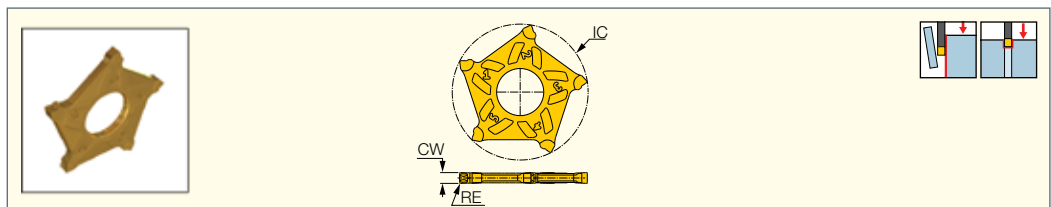

Designation	Dimensions					IC808G	Recommended Machining Data
	CW	RE	CWTOL ⁽¹⁾	RETOL ⁽²⁾	IC		f groove (mm/rev)
PENTA D40N300PB020	3.00	0.20	0.02	0.03	37.80	●	0.03-0.10

• For cutting speed recommendations and user guide, see pages 484-492
⁽¹⁾ Cutting width tolerance (+/-)
⁽²⁾ Corner radius tolerance (+/-)

For tools, see pages: PCHR/L-D-IQ (476) • PCHR/L-D-JHP (477)

PENTA D-R/L-PB

Pentagonal Inserts for Parting Bearing Steel and other Ductile Materials

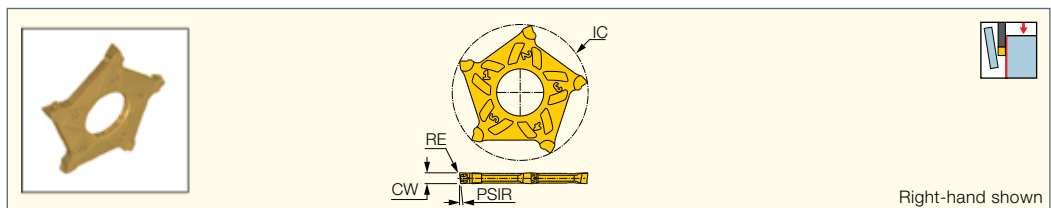

Designation	Dimensions					IC808G	Recommended Machining Data
	CW	RE	IC	PSIRL	PSIRR		f groove (mm/rev)
PENTA D40L300PB-6D	3.00	0.20	37.80	6.0	-	●	0.03-0.08
PENTA D40R300PB-6D	3.00	0.20	37.80	-	6.0	●	0.03-0.08
PENTA D40L300PB-15D	3.00	0.10	37.80	15.0	-	●	0.03-0.06
PENTA D40R300PB-15D	3.00	0.10	37.80	-	15.0	●	0.03-0.06

• For cutting speed recommendations and user guide, see pages 484-492
For tools, see pages: PCHR/L-D-IQ (476) • PCHR/L-D-JHP (477)

PENTACUT
PARTING & GROOVING LINE**PENTA 24R/L-J**

Inserts with 5 Cutting Edges
for Parting Tubes, Small
and Thin-Walled Parts

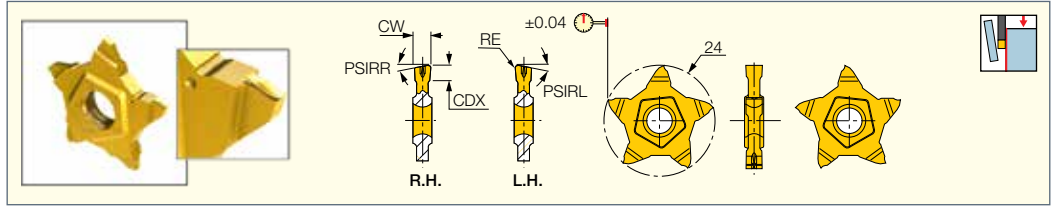

Designation	Dimensions							IC1008	Recommended Machining Data
	CW	CDX ⁽¹⁾	RE	CWTOL ⁽²⁾	PSIRL	PSIRR	CUTDIA ⁽³⁾		f groove (mm/rev)
PENTA 24L100J15D	1.00	3.50	0.06	0.02	15.0	-	7.0	●	0.02-0.06
PENTA 24R100J15D	1.00	3.50	0.06	0.02	-	15.0	7.0	●	0.02-0.06
PENTA 24L150J06D	1.50	5.00	0.10	0.02	6.0	-	10.0	●	0.03-0.09
PENTA 24L150J15D	1.50	5.00	0.06	0.02	15.0	-	10.0	●	0.03-0.08
PENTA 24R150J06D	1.50	5.00	0.06	0.02	-	6.0	10.0	●	0.03-0.09
PENTA 24R150J15D	1.50	5.00	0.06	0.02	-	15.0	10.0	●	0.03-0.08
PENTA 24L200J06D	2.00	6.00	0.10	0.02	6.0	-	12.0	●	0.04-0.10
PENTA 24L200J15D	2.00	6.00	0.10	0.02	15.0	-	12.0	●	0.04-0.09
PENTA 24R200J06D	2.00	6.00	0.10	0.02	-	6.0	12.0	●	0.04-0.10
PENTA 24R200J15D	2.00	6.00	0.10	0.02	-	15.0	12.0	●	0.04-0.09

• For cutting speed recommendations and user guide, see pages 484-492

⁽¹⁾ Cutting depth maximum

⁽²⁾ Cutting width tolerance (+/-)

⁽³⁾ For grooving and parting depths relative to part diameter, see page 481

For tools, see pages: PCAD RE/LE-JHP (301) • PCADR/L (300) • PCADR/L-JHP (301) • PCHBR/L (302) • PCHPR/L (300) • PCHR/L-24 (297) • PCHR/L-24-JHP (298) • PCHR/L-24-JHP-MC (298)

PENTACUT
PARTING & GROOVING LINE**PENTA 24R-C**

Inserts with 5 Cutting Edges
for Parting Bars, Hard Materials
and Tough Applications

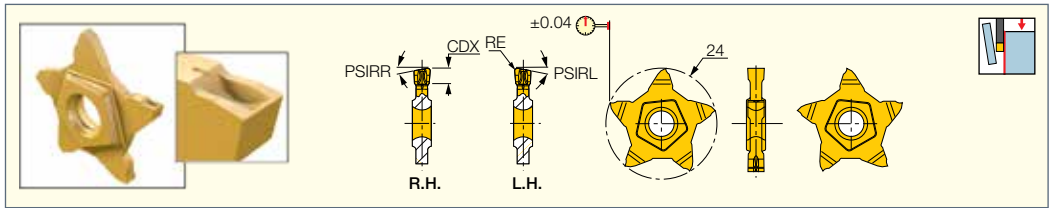

Designation	Dimensions					IC1008	Recommended Machining Data
	CW	RE	CWTOL ⁽¹⁾	CDX	PSIRR		f groove (mm/rev)
PENTA 24R150C06D	1.50	0.06	0.02	5.00	6.0	●	0.03-0.10
PENTA 24R200C06D	2.00	0.10	0.02	6.00	6.0	●	0.04-0.12

• For cutting speed recommendations and user guide, see pages 484-492

⁽¹⁾ Cutting width tolerance (+/-)

For tools, see pages: PCAD RE/LE-JHP (301) • PCADR/L (300) • PCADR/L-JHP (301) • PCHBR/L (302) • PCHPR/L (300) • PCHR/L-24 (297) • PCHR/L-24-JHP (298) • PCHR/L-24-JHP-MC (298)

PENTA 24R/L-Z
Inserts with 5 Cutting Edges
for Parting Tubes, Small
and Thin-Walled Parts

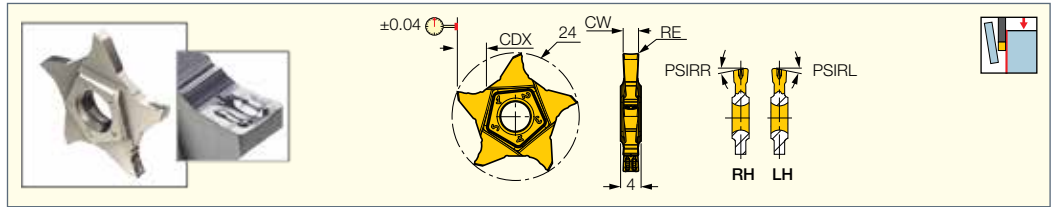

Designation	Dimensions						IC1008	Recommended Machining Data
	CW	PSIRL	PSIRR	RE	CUTDIA	CDX ⁽¹⁾		
PENTA 24L150Z06D	1.50	6.0	-	0.06	10.0	5.00	●	0.03-0.09
PENTA 24L150Z15D	1.50	15.0	-	0.06	10.0	5.00	●	0.03-0.08
PENTA 24R150Z06D	1.50	-	6.0	0.06	10.0	5.00	●	0.03-0.09
PENTA 24R150Z15D	1.50	-	15.0	0.06	10.0	5.00	●	0.03-0.08
PENTA 24L200Z06D	2.00	6.0	-	0.10	12.8	6.40	●	0.04-0.10
PENTA 24L200Z15D	2.00	15.0	-	0.10	12.8	6.40	●	0.04-0.09
PENTA 24R200Z06D	2.00	-	6.0	0.10	12.8	6.40	●	0.04-0.10
PENTA 24R200Z15D	2.00	-	15.0	0.10	12.8	6.40	●	0.04-0.09
PENTA 24L300Z06D	3.00	6.0	-	0.20	12.8	6.40	●	0.04-0.13
PENTA 24L300Z15D	3.00	15.0	-	0.20	12.8	6.40	●	0.04-0.12
PENTA 24R300Z06D	3.00	-	6.0	0.20	12.8	6.40	●	0.04-0.15
PENTA 24R300Z15D	3.00	-	15.0	0.20	12.8	6.40	●	0.04-0.14

• Cutting edge with high positive rake, suitable for parting tubes, thin walled parts and for small diameters • Suitable for machining soft materials and bearing steel at low to medium feeds • For cutting speed recommendations and user guide, see pages 484-492

⁽¹⁾ Cutting depth maximum

For tools, see pages: PCAD RE/LE-JHP (301) • PCADR/L (300) • PCADR/L-JHP (301) • PCHBR/L (302) • PCHPR/L (300) • PCHR/L-24 (297) • PCHR/L-24-JHP (298) • PCHR/L-24-JHP-MC (298)

W=0.02	T _{max} ⁽¹⁾	T _{max} / D _{max}	D _{max} as a Function of Parting / Grooving Depth (T) for PENTA 24 Inserts									
			T _{≤3.0}	T _{≤3.5}	T _{≤4.0}	T _{≤4.5}	T _{≤5.0}	T _{≤5.5}	T _{≤6.0}	T _{≤6.2}	T _{≤6.4}	
W=0.50	1.0	1.0 / N.L.	-	-	-	-	-	-	-	-	-	-
W=0.50	2.5	2.5 / N.L.	-	-	-	-	-	-	-	-	-	-
W=0.80	1.6	1.6 / N.L.	-	-	-	-	-	-	-	-	-	-
W=1.00	3.5		N.L.	250	-	-	-	-	-	-	-	-
1.04 ≤ W ≤ 1.40	2.0	2.0 / N.L.	-	-	-	-	-	-	-	-	-	-
W=1.47	2.5	2.5 / N.L.	-	-	-	-	-	-	-	-	-	-
W=1.50	5.0		N.L.	470	210	70	30	-	-	-	-	-
1.57 ≤ W ≤ 1.96	3.0		N.L.	-	-	-	-	-	-	-	-	-
W=2.00	6.0 ⁽²⁾		N.L.	470	210	130	75	45	20	-	-	-
2.22 ≤ W ≤ 2.30	3.5		N.L.	250	-	-	-	-	-	-	-	-
2.39 ≤ W ≤ 2.50	5.0		N.L.	470	210	70	30	-	-	-	-	-
2.70 ≤ W ≤ 3.18	6.2		N.L.	470	210	135	100	70	40	20	-	-
3.19 ≤ W ≤ 3.74	6.4		N.L.	350	180	115	80	52	32	26	20	-
3.75 ≤ W ≤ 4.00	6.2		N.L.	350	180	115	80	62	32	18	-	-
4.01 ≤ W ≤ 4.23	6.2		N.L.	350	180	115	80	62	42	25	-	-

⁽¹⁾ D_{max} for parting = 2 x T_{max}

⁽²⁾ For full radius insert, T_{max} = 3.0, D_{max} = No limit

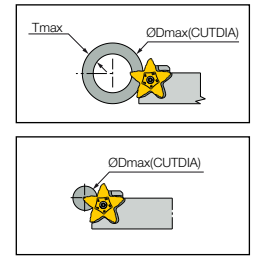

PENTACUT
PARTING & GROOVING LINE

PENTA 24R-P

Inserts with 5 Cutting Edges for Parting Soft Materials, Thin Walls and Miniature Parts

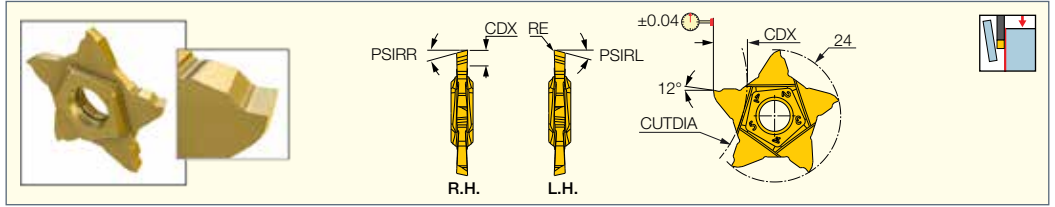

Designation	Dimensions						IC1008	Recommended Machining Data
	CW	CDX ⁽¹⁾	RE	CWTOL ⁽²⁾	CUTDIA ⁽³⁾	PSIRR		f groove (mm/rev)
PENTA 24R100P06D	1.00	3.50	0.05	0.02	7.2	6.0	●	0.02-0.04
PENTA 24R100P15D	1.00	3.50	0.05	0.02	7.2	15.0	●	0.02-0.03
PENTA 24R150P06D	1.50	5.00	0.05	0.02	11.0	6.0	●	0.02-0.05
PENTA 24R150P15D	1.50	5.00	0.05	0.02	11.0	15.0	●	0.02-0.04
PENTA 24R200P06D	2.00	6.00	0.05	0.02	12.6	6.0	●	0.02-0.07
PENTA 24R200P15D	2.00	6.00	0.05	0.02	12.6	15.0	●	0.02-0.05

• For cutting speed recommendations and user guide, see pages 484-492

⁽¹⁾ Cutting depth maximum

⁽²⁾ Cutting width tolerance (+/-)

⁽³⁾ For grooving and parting depths relative to part diameter, see page 481

For tools, see pages: PCAD RE/LE-JHP (301) • PCADR/L (300) • PCADR/L-JHP (301) • PCHBR/L (302) • PCHPR/L (300) • PCHR/L-24 (297) • PCHR/L-24-JHP (298) • PCHR/L-24-JHP-MC (298)

PENTACUT
PARTING & GROOVING LINE

PENTA 34R/L-C

Inserts with 5 Cutting Edges for Parting Hard Materials, Tough and General Applications

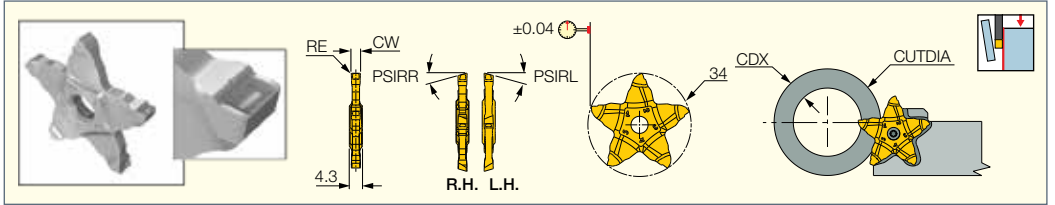

Designation	Dimensions						IC908	Recommended Machining Data
	CW	RE	CUTDIA ⁽¹⁾	CDX	PSIRL	PSIRR		f groove (mm/rev)
PENTA 34L150C08D	1.50	0.07	18.0	8.00	8.0	-	●	0.03-0.08
PENTA 34R150C08D	1.50	0.07	18.0	8.00	-	8.0	●	0.03-0.08
PENTA 34L200C06D	2.00	0.10	18.0	8.00	6.0	-	●	0.04-0.12
PENTA 34R200C06D	2.00	0.10	18.0	8.00	-	6.0	●	0.04-0.12
PENTA 34L200C15D	2.00	0.10	18.0	8.00	15.0	-	●	0.04-0.10
PENTA 34R200C15D	2.00	0.10	18.0	8.00	-	15.0	●	0.04-0.10
PENTA 34L300C06D	3.00	0.20	20.0	10.00	6.0	-	●	0.04-0.14
PENTA 34R300C06D	3.00	0.20	20.0	10.00	-	6.0	●	0.06-0.14
PENTA 34L300C15D	3.00	0.20	20.0	10.00	15.0	-	●	0.04-0.10
PENTA 34R300C15D	3.00	0.20	20.0	10.00	-	15.0	●	0.06-0.12

• For cutting speed recommendations and user guide, see pages 484-492

⁽¹⁾ For grooving and parting depths relative to part diameter, see page 483

For tools, see pages: PCADR/L (300) • PCADR/L 34N-RE (301) • PCHBR/L (302) • PCHPR/L (300) • PCHR/L-34 (299) • PCHR/L-34-JHP (299)



PENTA 34R/L-J

Inserts with 5 Cutting Edges for Parting Tubes, Small and Thin-Walled Parts

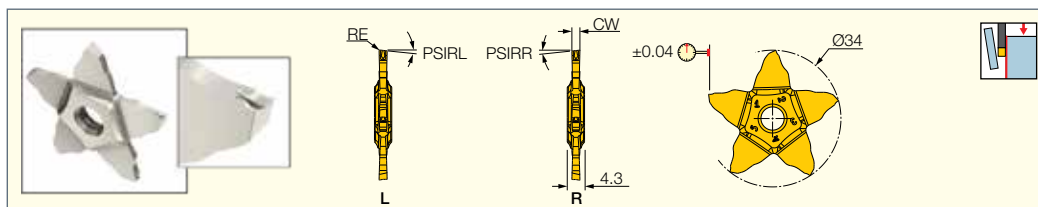

Designation	Dimensions						IC908	Recommended Machining Data
	CW	RE	CWTOL ⁽¹⁾	CUTDIA ⁽²⁾	PSIRL	PSIRR		
PENTA 34L150J06D	1.50	0.07	0.02	18.0	6.0	-	●	0.03-0.09
PENTA 34L150J15D	1.50	0.07	0.02	18.0	15.0	-	●	0.03-0.08
PENTA 34R150J06D	1.50	0.07	0.02	18.0	-	6.0	●	0.03-0.09
PENTA 34R150J15D	1.50	0.07	0.02	18.0	-	15.0	●	0.03-0.08
PENTA 34L200J06D	2.00	0.10	0.02	18.0	6.0	-	●	0.04-0.10
PENTA 34L200J15D	2.00	0.10	0.02	18.0	15.0	-	●	0.04-0.09
PENTA 34R200J06D	2.00	0.10	0.02	18.0	-	6.0	●	0.04-0.10
PENTA 34R200J15D	2.00	0.10	0.02	18.0	-	15.0	●	0.04-0.09

• For cutting speed recommendations and user guide, see pages 484-492

⁽¹⁾ Cutting width tolerance (+/-)

⁽²⁾ For grooving and parting depths relative to part diameter, see page 483

For tools, see pages: PCADR/L (300) • PCADR/L 34N-RE (301) • PCHBR/L (302) • PCHPR/L (300) • PCHR/L-34 (299) • PCHR/L-34-JHP (299)

PENTA 34R/L-PB

Pentagonal Inserts for Parting Bearing Steel and other Ductile Materials

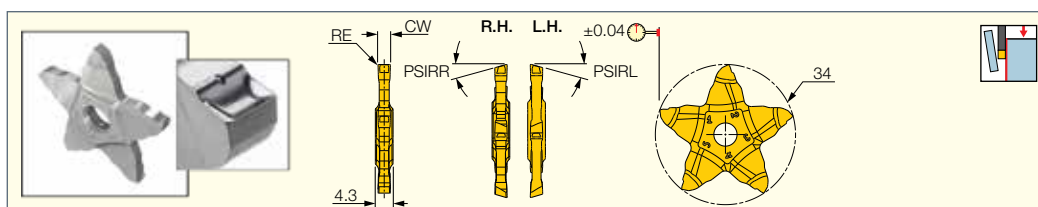

Designation	Dimensions					IC908	Recommended Machining Data
	CW	RE	CUTDIA	PSIRL	PSIRR		
PENTA 34R150PB-6D	1.50	0.07	18.0	-	6.0	●	0.03-0.05
PENTA 34L150PB-6D	1.50	0.07	18.0	6.0	-	●	0.03-0.05
PENTA 34R200PB-6D	2.00	0.10	18.0	-	6.0	●	0.03-0.06
PENTA 34L200PB-6D	2.00	0.10	18.0	6.0	-	●	0.03-0.06
PENTA 34R300PB-6D	3.00	0.20	20.0	-	6.0	●	0.03-0.08
PENTA 34L300PB-6D	3.00	0.20	20.0	6.0	-	●	0.03-0.08

• For cutting speed recommendations and user guide, see page 483

For tools, see pages: PCADR/L (300) • PCADR/L 34N-RE (301) • PCHBR/L (302) • PCHPR/L (300) • PCHR/L-34 (299) • PCHR/L-34-JHP (299)

W _{±0.02}	Dmax as a Function of Parting / Grooving Depth (T) for PENTA 34 Inserts						
	T ≤ 5.0	T ≤ 6.0	T ≤ 7.0	T ≤ 8.0	T ≤ 8.5	T ≤ 9.0	T ≤ 10.0
1.50 ≤ W ≤ 2.69	N.L.	350	165	100	55	-	-
2.70 ≤ W ≤ 4.00						55	20

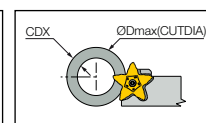
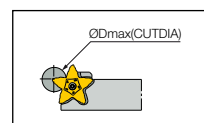

Dmax for parting = 2 x Tmax
N.L. = No Limit



Machining Data

ISO	Material	Condition	Tensile Strength [N/mm ²]	Hardness HB	Material No.	
P	Non-alloy steel and cast steel, free cutting steel	< 0.25 %C	Annealed	420	125	1
		>= 0.25 %C	Annealed	650	190	2
		< 0.55 %C	Quenched and tempered	850	250	3
		>= 0.55 %C	Annealed	750	220	4
	Low alloy steel and cast steel (less than 5% of alloying elements)	Quenched and tempered		1000	300	5
		Annealed		600	200	6
		Quenched and tempered		930	275	7
				1000	300	8
				1200	350	9
	High alloyed steel, cast steel, and tool steel	Annealed		680	200	10
		Quenched and tempered		1100	325	11
	Stainless steel and cast steel	Ferritic/martensitic		680	200	12
		Martensitic		820	240	13
M	Stainless steel	Austenitic	600	180	14	
K	Grey cast iron (GG)	Ferritic/pearlitic		180	15	
		Pearlitic		260	16	
	Cast iron nodular (GGG)	Ferritic		160	17	
		Pearlitic		250	18	
	Malleable cast iron	Ferritic		130	19	
		Pearlitic		230	20	
N	Aluminum-wrought alloy	Not cureable		60	21	
		Cured		100	22	
	Aluminum-cast, alloyed	<=12% Si	Not cureable		75	23
			Cured		90	24
		>12% Si	High temperature		130	25
	Copper alloys	>1% Pb	Free cutting		110	26
			Brass		90	27
			Electrolytic copper		100	28
	Non-metallic	Duroplastics, fiber plastics				29
Hard rubber				30		
S	High temp. alloys	Fe based	Annealed		200	31
			Cured		280	32
		Ni or Co based	Annealed		250	33
			Cured		350	34
			Cast		320	35
	Titanium Ti alloys			RM 400		36
		Alpha+beta alloys cured		RM 1050		37
H	Hardened steel	Hardened		55 HRC	38	
		Hardened		60 HRC	39	
	Chilled cast iron	Cast		400	40	
	Cast iron	Hardened		55 HRC	41	

Parting Speed Recommendations

Material No.	IC907/807	IC30N	IC354	IC1010/ IC908/808/1008	IC5400	IC1030/ IC830/928/1028	IC328
1	160 - 240	130 - 190	115 - 170	135 - 200	110 - 160	100 - 150	95 - 140
2	150 - 205	120 - 160	105 - 145	125 - 170	100 - 135	95 - 125	85 - 120
3	115 - 170	90 - 135	80 - 120	95 - 140	75 - 110	70 - 105	65 - 100
4	125 - 190	100 - 150	90 - 135	105 - 160	85 - 130	80 - 120	75 - 110
5	100 - 160	80 - 130	70 - 115	85 - 135	70 - 110	65 - 100	60 - 95
6	125 - 190	100 - 150	90 - 135	105 - 160	85 - 130	80 - 120	75 - 110
7	100 - 170	80 - 135	70 - 120	85 - 140	70 - 110	65 - 105	60 - 100
8	100 - 160	80 - 130	70 - 115	85 - 135	70 - 110	65 - 100	60 - 95
9	90 - 150	70 - 120	65 - 105	75 - 125	60 - 100	55 - 95	50 - 85
10	150 - 205	120 - 160	105 - 145	125 - 170	100 - 135	95 - 125	85 - 120
11	90 - 150	70 - 120	65 - 105	75 - 125	60 - 100	55 - 95	50 - 85
	IC20N	IC907/807	IC808	IC908	IC5400	IC830/928/1028	IC328
12	170 - 300	115 - 210	110 - 200	105 - 190	85 - 150	80 - 140	75 - 135
13	150 - 290	105 - 200	100 - 190	95 - 180	75 - 145	70 - 135	65 - 125
	IC20N	IC907/807	IC808	IC908	IC5400	IC830/928/1028	IC328
14	140 - 260	95 - 175	90 - 170	85 - 160	70 - 130	65 - 120	60 - 110
	IC907/807	IC808	IC908	IC20			
15	170 - 305	145 - 270	140 - 255	70 - 125			
16	150 - 215	130 - 190	125 - 180	60 - 90			
17	160 - 265	140 - 230	135 - 220	65 - 110			
18	125 - 205	110 - 180	105 - 170	50 - 85			
19	190 - 320	170 - 280	160 - 265	80 - 130			
20	160 - 265	140 - 230	135 - 220	65 - 110			
	IC907/807	IC908/808	IC20				
21	360 - 1080	330 - 990	300 - 900				
22	270 - 900	250 - 825	225 - 750				
23	270 - 900	250 - 825	225 - 750				
24	180 - 540	165 - 495	150 - 450				
25	180 - 360	165 - 330	150 - 300				
26	180 - 360	165 - 330	150 - 300				
27	130 - 270	120 - 250	110 - 225				
28	90 - 180	80 - 165	75 - 150				
29	40 - 180	40 - 165	35 - 150				
	IC807	IC907	IC908	IC808	IC830/328/928/1028	IC20	
31	50 - 70	45 - 70	40 - 60	40 - 65	30 - 45	30 - 40	
32	35 - 55	35 - 50	30 - 45	30 - 45	20 - 35	20 - 30	
33	35 - 55	35 - 50	30 - 45	30 - 45	20 - 35	20 - 30	
34	30 - 50	30 - 45	25 - 40	25 - 40	20 - 30	15 - 30	
35	25 - 35	25 - 35	20 - 30	20 - 30	15 - 20	15 - 20	
36	115 - 190	110 - 185	95 - 160	100 - 170	70 - 120	65 - 110	
37	40 - 50	40 - 50	35 - 45	35 - 45	30 - 40	40 - 50	
	IC807	IC907	IC808	IC908			
38	35-45	30-40	30-40	25-35			
39	30-40	25-35	25-35	20-30			
40	45-65	40-60	40-60	30-50			
41	40-50	35-45	35-45	30-40			

Grades	ISO	Coating Layers
S.T. IC807	P10-P20 M05-M15 K15-K30 S10-S20 H05-H15	TiN AlTiCrN
S.T. IC808	P15-P30 M20-M30 K20-K40 S15-S30 H20-H30	TiN AlTiCrN
S.T. IC830	P30-P45 M25-M45	TiN AlTiCrN
IC907	P10-P20 M05-M15 K15-K30 S10-S20 H05-H15	AlTiCrN
IC908	P15-P30 M20-M30 K20-K40 S15-S30 H20-H30	AlTiCrN
IC1008	P15-P30 M20-M30 K20-K40 S15-S30 H20-H30	TiN AlTiCrN
IC1010	P15-P30 M20-M30 K20-K40 S15-S30 H20-H30	TiN AlTiN
IC1030	P30-P45 M25-M45	TiN AlTiN
S.T. IC5400	P30-P45 M25-M45	Al ₂ O ₃ TiCN

S.T. SUMO TEC ■ PVD COATED ■ CVD COATED

Grades	ISO	Coating Layers
IC30N	P10-P30 M10-M20	
IC20	N05-N25 S10-S25 K10-K20 H10-H20	

■ CERMET ■ UNCOATED

Recommended Applications

A very hard submicron substrate with **AlTiCrN + TiN PVD** coating and a special **SUMO TEC** surface treatment. Suitable for parting and grooving of steel, alloy steels, austenitic stainless steel, high temperature alloys and hard steels at medium to high cutting speeds.

A tough submicron substrate with **AlTiCrN + TiN PVD** coating and a special **SUMO TEC** surface treatment. Recommended for general use in parting and grooving operations on large variety of materials as well as steel, alloy steels, austenitic stainless steel, heat resistant alloys at low to medium cutting speeds.

AlTiCrN + TiN PVD coated grade with a special **SUMO TEC** surface treatment on very tough substrate for parting and grooving of steel and stainless steel at low to medium speeds and medium to high feeds. The grade is recommended for interrupted cut and machining at unstable conditions.

A very hard submicron substrate with **AlTiCrN PVD** coating. Suitable for parting and grooving of steel, alloy steels, austenitic stainless steel, high temperature alloys and hard steels at medium to high cutting speeds.

A tough submicron substrate with **AlTiCrN PVD** coating. Recommended for general use in parting and grooving operations on large variety of materials as well as steel, alloy steels, stainless steel, high temperature alloys at low to medium cutting speeds.

A tough submicron substrate with **AlTiCrN + TiN PVD** coating. Recommended for general use in parting and grooving operations on large variety of materials as well as steel, alloy steels, stainless steel, high temperature alloys at low to medium cutting speeds.

AlTiN + TiN PVD coated grade overlays on tough submicron substrate. Recommended for general use in parting and grooving operations on large variety of materials as well as steel, alloy steels, austenitic stainless steel, high temperature alloys at low to medium cutting speeds.

AlTiN + TiN PVD coated grade on very tough substrate for parting and grooving applications at high feeds and low to medium speeds. Suitable for steels and stainless steel. The grade is recommended for interrupted cut and machining at unstable conditions.

MTCVD TiCN and **Al2O3** coated grade with the **SUMO TEC** post coating treatment on very tough substrate for parting and grooving of steel and stainless steel at low to medium cutting speeds under stable and unstable cutting conditions.

Recommended Applications

A cermet grade, used for parting and grooving applications. Recommended for steels and stainless steel at medium to high cutting speeds and low feeds, provides excellent surface finish. Features very good wear resistance and prevents build-up edge.

An uncoated carbide grade. Used for parting and grooving of aluminum and other nonferrous materials at medium to high cutting speeds. Suitable also for titanium and high temperature alloys machining at low cutting speeds.

Parting and Grooving

Selection of Inserts

For a proper match of insert and cutting material to application, the following variables must be taken into consideration:

- Width of cut (width of insert)
- Chipformer style
- Lead angle
- Corner radius
- Carbide grade

Width of Cut (W.O.C.) and Depth of Cut (D.O.C.)

In selecting **W.O.C.**, the main factor to consider is the required **D.O.C.**. The ratio $D.O.C. \approx 8 \times W.O.C.$ is of practical use on alloy steel of average machinability.

For example, applying a 3 mm **W.O.C.** insert **TAG N3C** to cut-off a 48 mm solid bar.

Additional factors which affect **D.O.C.** capacity, relative to the ratio, are:

Holder or Blade Size

To minimize risk of vibration and deflection always choose:

- Blade or toolholder with smallest possible overhang.
- Toolholder with maximum shank dimension.
- Blade height (**B**) dimension which is larger than T_{max} .
- Blade or holder with maximum blade width (largest possible insert seat size).

Example:

- A **W.O.C.** 9.5 mm on blade TGFH 53K-9 ($B=52.6$ mm) extends the ratio of **D.O.C.** to **W.O.C.** by some 50% to 120 mm.

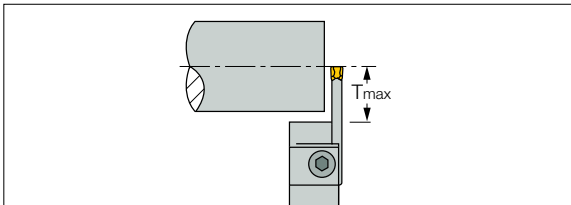

Insert Support

A self-clamped tool is recommended for deep radial machining.

A screw-clamp holder is recommended for axial and small **D.O.C.** machining.

90° Mounting

It is very important that the insert is mounted at 90° to the center line of the workpiece in order to obtain perpendicular surfaces and reduce the risk of vibration.

Workpiece Machinability

The workpiece material affects all of the above factors.

Machine Power and Setup Rigidity

Excessive **W.O.C.** on a light-duty machine will yield vibration and may even stop spindle rotation.

Expensive Workpiece Material

On costly metals the narrowest applicable **W.O.C.** should be used.

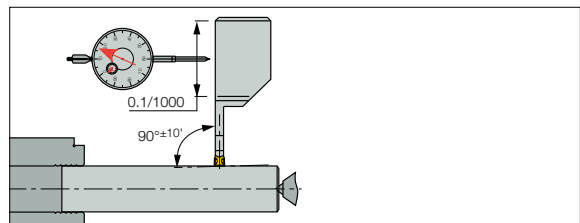
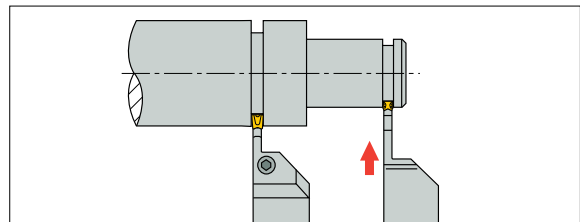

Insert Positioning

The Twisted Insert for Cut-Off and Grooving Applications

Machining depths longer than insert length is made possible with the double-ended, twisted insert body. The rear edge is slanted in relation to the frontal edge so it does not come into contact with the machined groove surface when the tool penetrates deeply into the workpiece.

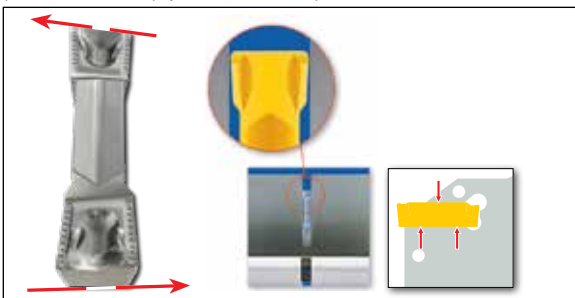

Clamping

Extended, prismatic surfaces guarantee reliable, foolproof clamping even in unstable machining conditions.

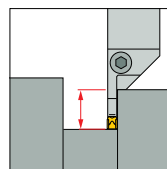

Screw-Clamping

Small diameters (**D.O.C.**) with screw-clamped Inserts

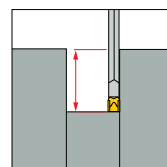

Self-Clamping

Large diameters (**D.O.C.**) with self-clamped Inserts

Setup

- The optimal cutting edge height above the center of **TANG-GRIP** tools is up to 0.08 mm + 0.025 mm **W.O.C.**, an advantage when cutting solid bar to center
- Cut-off as close to chuck as possible
- On new applications, first machine in the low or middle range of recommended speeds and feeds

Machining

- Consistency of speed and feed improves performance
- Apply coolant abundantly
- Secure inserts into clean pockets
- Cutting forces on soft workpiece materials may be insufficient to push insert well into pocket. Tap insert into place using a plastic hammer
- On a conventional lathe, lock the carriage to prevent axial motion during cut-off

Usage

- Replace worn inserts promptly, the price of a new one is much less than the risk of damage from continuing with one that is worn out
- Replace blades that have worn or damaged pockets
- Never try to repair damaged pockets
- Chip curling is dependent on the chipformer type and the machining conditions

Chipformer Features

- Narrows the chip
- Eliminates friction with groove walls, prevents chip jam overload
- Permits higher feeds
- Produces unscratched surfaces, eliminating additional facing
- Curls the chips into compact spirals for easy disposal

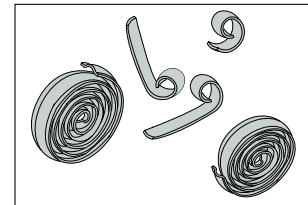
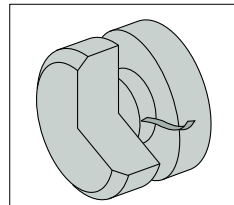
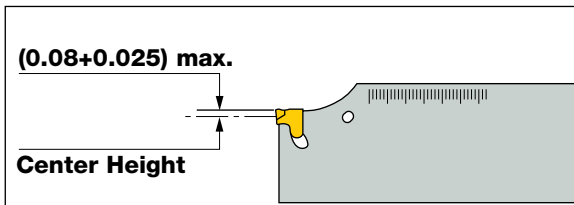

Selection of Corner Radius

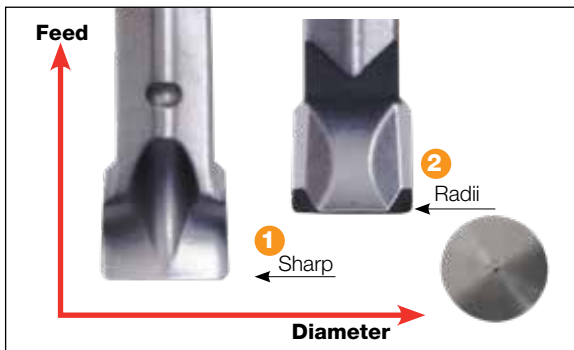

1. A smaller corner radius (r) will reduce the load on the workpiece and produce a smaller size burr
2. At the same time, a large corner radius allows for higher feeds and increased tool life

"S" Sharp Corners

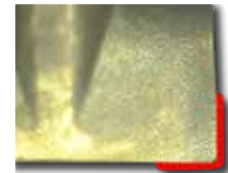

JS/P

- Cutting edge with positive rake and sharp corners
- When a minimum burr (pip) size is essential
- For small feeds
- For small diameters or thin walls
- For **CNCs**, multi-spindle and screw machines

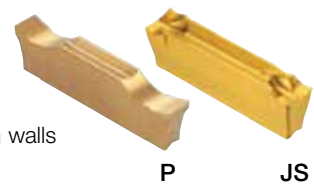

Standard Corner Radius



- Standard medium corner size
- For general applications and materials



"B" Large Corner Radius

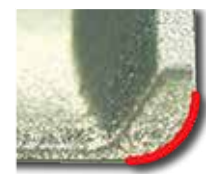

- Reinforced corners with stronger cutting edge
- For tough applications and interrupted cuts



Lead Angle

Lead angle (**K**) on cut-off inserts reduces size of burr remaining on workpiece. Increasing the lead angle reduces the burr, but also reduces possible feed rates and tool life. Therefore, neutral inserts are recommended for parts on which a burr is tolerated.

turning direction. When looking toward the chuck from the workpiece, **R.H.**=counterclockwise (**C.C.**) rotation of workpiece and **L.H.**=clockwise (**C**) rotation of workpiece. **C.C.** requires right-hand inserts; **C** requires left-hand inserts.

Insert designations such as **TAG R...** **DGR (R.H.)** and **TAG L...** **DGL (L.H.)** comply with standard terms for

A neutral insert with 0° lead angle increases **D.O.C.** capacity.

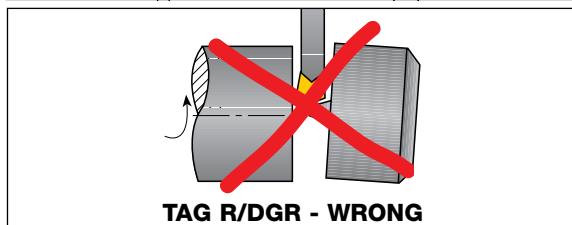
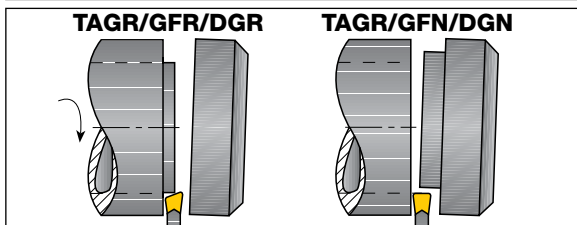
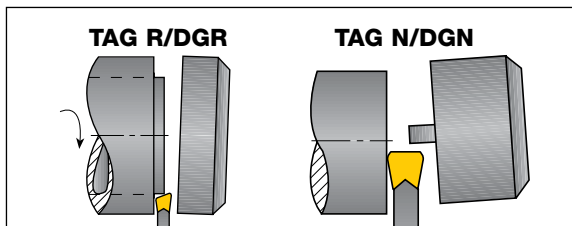
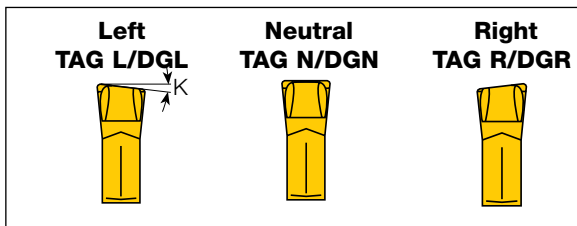

Neutral Insert vs. Lead Angle Type

Lifetime	Chip Control	Burr Size	Surface Finish	Part Straightness	
✓	✓		✓	✓	
		✓			

General Rules for Specific Applications

Chamfer and Cut-Off

1. Break in and/or groove
2. Chamfer
3. Cut-off

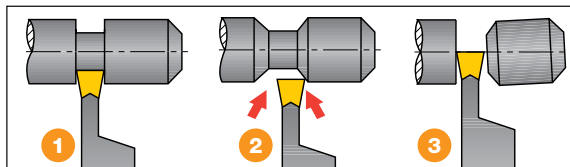

V-Belt Pulley Grooves

1. Break in
2. Multiple plunge to depth at minor width of groove
- 3-4. Bevel, plunge and turn to minor diameter

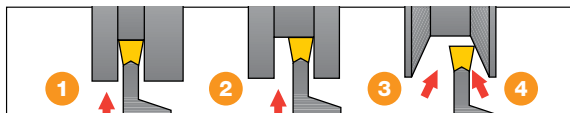

Neck Recessing

5. Multiple plunge grooves
6. Necking On neck turning, DOC (a)=up to size of insert corner radius

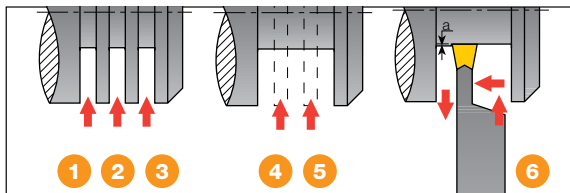

Cut-Off on Eccentric Tubes

Inserts with 4° lead angle are usually recommended for tubes. However, the combination of eccentric bore and machine resiliency may increase feed-snap on breakthrough and damage the cutting edge. Changing to 6° lead angle inserts will moderate breakthrough. Alternatively, inserts with an extra negative rake-land that strengthens the cutting edge are available on request.

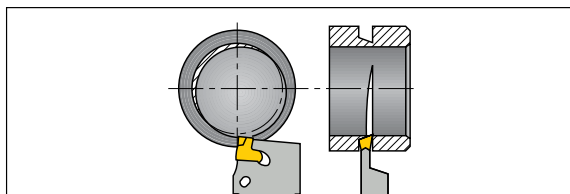

Clamping / Extraction Instructions

The tools are equipped with a user-friendly clamping and extraction device



- ETG 5-7 (for 5-7 mm tools)
- ETG 2 (for 2 mm tools)
- ETG 1.4 (for 1.4 mm tools)
- ETG 8-12 Extractor for 8 to 12.7 mm Inserts

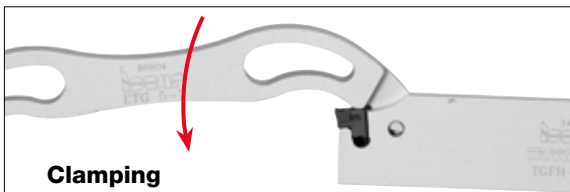
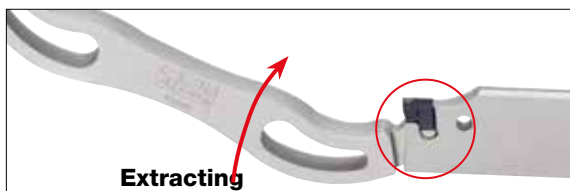
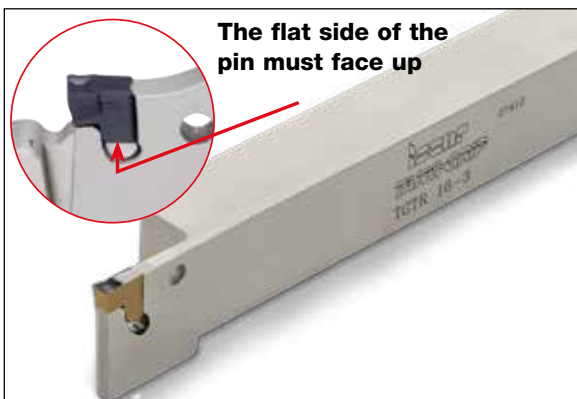

ETG 3-4 (for 3 and 4 mm tools)

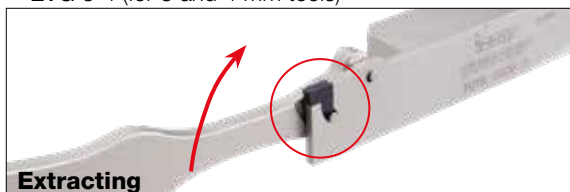

Clamping / Extraction Instructions

DO-GRIP

Extractor for DGN/R/L Double-Ended Inserts
DO-GRIP Insert Clamping/Extracting

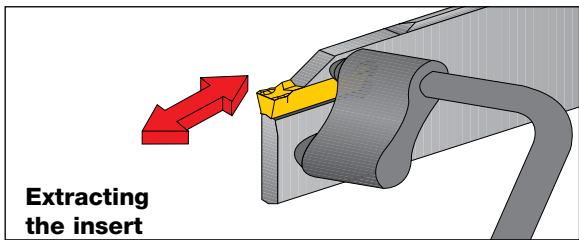

Eccentric Extractor for Insert Indexing
Simple to operate; controlled rotation requires low force; guarantees limited upper jaw movement and secures maximum load on blade.

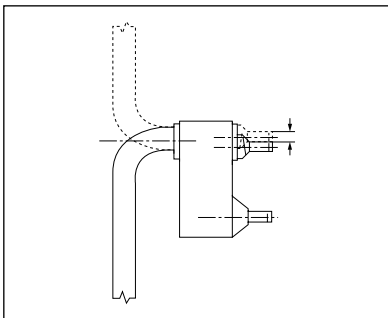

Grade Application Range

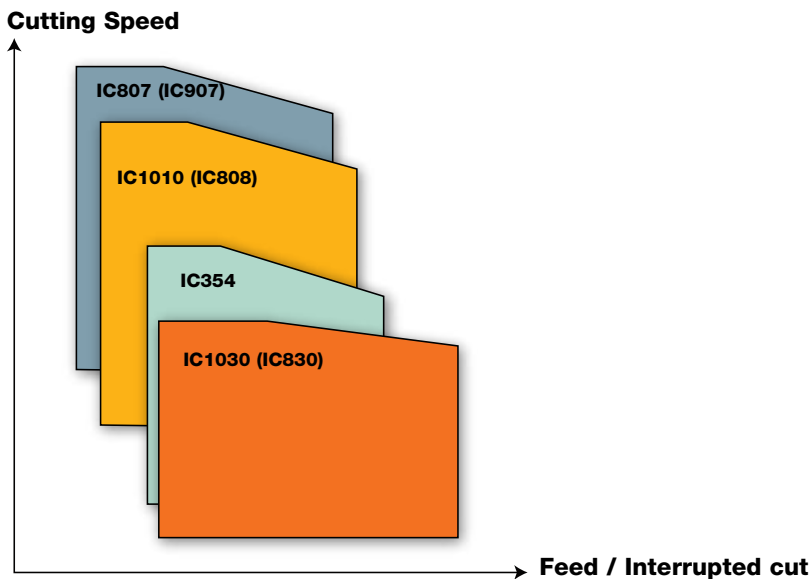

Selection Guide for Parting Grades

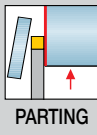
Material groups	ISO P		ISO M	ISO K	ISO N	ISO S	ISO H
	1-11 Steel	12-13 Stainless Steel Ferritic & Martensitic	14 Stainless Steel Austenitic&Duplex (Ferritic-Austenitic)	15-20 Cast Iron	21-28 Non-ferrous	31-37 High Temperature Alloys	38-41 Hard Steel & Cast Iron
	Harder ↑ ↓ Tougher	IC807 (IC907)	IC807 (IC907)	IC807 (IC907)		IC20	IC807 (IC907)
		IC808	IC808	IC808	IC807 (IC907)	IC20	IC807 (IC907)
		IC1010	IC1010	IC1010	IC20	IC808	IC808
		IC830	IC830	IC830	IC808	IC1010	IC1010
		IC1030	IC1030	IC1030	IC1010	IC830	IC830
		IC1030	IC1030	IC1030		IC1030	IC1030

■ First choice



MODULAR GRIP ADAPTATIONS

Modular Adaptations Systems for Turning Lathes and Multi-Spindle Machine Tools Carrying ISCAR's MODULAR-GRIP Adapters Featuring Directed Internal Coolant Channels

Product Features

- The unique combination of a rigid tool and efficient coolant improves the insert's tool life, surface finish and part straightness
- Designed for high-pressure coolant up to 150 bars and **also very efficient when using low** coolant pressure of 7-10 bars
- No coolant tubes involved, which means no obstruction for chip evacuation
- Each adapter can carry several types of **MODULAR-GRIP** blades
- Excellent tool location repeatability after blade replacement for fast set-up
- Easy and user-friendly mounting

Available adapters for the following specific machines:

- STAR
- DOOSAN
- MAZAK
- MORI SEIKI
- BIGLIA
- MIYANO
- NAKAMURA-Tome
- INDEX ABC
- TRAUB
- OKUMA

Multi-Spindle machine tools

- INDEX CNC
- Göltenbodt

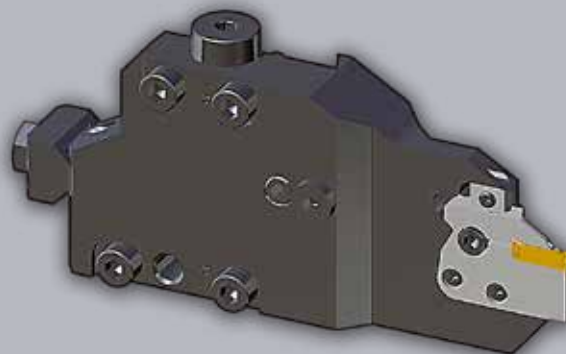
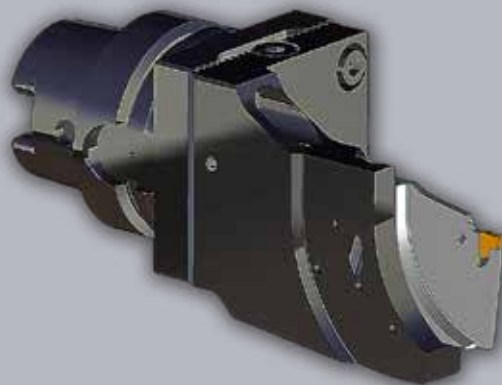

All trademarks and logos are the property of their respective companies

TABLE OF CONTENTS

Toolholder Systems for Multi-Spindle Machines

Features and Benefits

INDEX CNC Multi-Spindle Machines	496
Göltenbodt GWS System	497
Modular Grip Adapter with Internal Coolant	498

Tool Selection

INDEX CNC Multi-Spindle Machines	499
Göltenbodt GWS System	500

Technical Information

INDEX CNC Multi-Spindle Machines	501
Göltenbodt GWS System	502

Toolholder Systems for Turning Lathes

User Guide

ISCAR Modular System / Overview	503
VDI Tools for STAR Turret	505
VDI Tools for Disc-Type Turret	506
BMT Tools for DOOSAN Machines	507
Tools for MORI SEIKI Machines	508
Tools for MAZAK Machines	509
Tools with CAMFIX Adaptation	510
Tools with HSK Shank	511
Tools for BIGLIA Machines	512
Tools for MIYANO Machines	512
Tools for NAKAMURA-TOME Machines.....	512
Tools for INDEX ABC Machines	513
Tools for TRAUB Machines.....	514
MODULAR-GRIP-XL Adaptation.....	515
Tool Design - Overview.....	516

Tool Selection Technical Information

VDI Tools for STAR Turret	518
VDI Tools for Disc-Type Turret.....	519
BMT tools for DOOSAN Machines	520
Tools for MORI SEIKI Machines	521
Tools for MAZAK Machines	522
Tools with CAMFIX Adaptation	523
Tool with HSK-T Shank	524
Tools for BIGLIA Machines	525
Tools for MIYANO Machines	526
Tools for NAKAMURA-TOME Machines.....	527
Tools for OKUMA Machines.....	528
ISCAR Modular System Intermediate Holders	529
Tools for TRAUB Machines.....	530
Tools for INDEX ABC Machines	532

MODULAR-GRIP • JETCUT

Toolholder Systems for INDEX CNC
Multi-Spindle Machines with
MODULAR-GRIP Adaptation
and Directed Internal Coolant

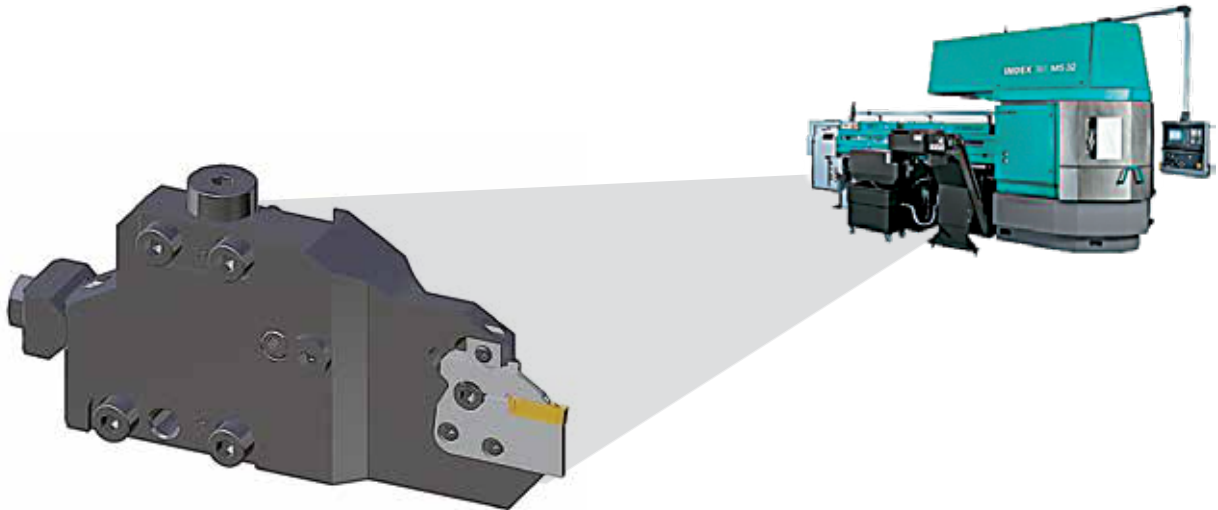

Features and Benefits of Directed Internal Coolant

	Customized to the work space	No coolant tube	Coolant connection through the slide	Easy indexing
Features:	<p>Bar stopper Adapter</p>		<p>Slide Coolant hole</p>	
Benefits:	<ul style="list-style-type: none"> • High-end stability due to optimized holder design • No interfering contour with the sub-spindle • Reduced setup time due to fixed adapter length • Exchangeable bar stopper 	<ul style="list-style-type: none"> • Chips do not accumulate in the work space (no coolant tube/hose required) • Reliable coolant supply due to fixed flow orientation (no adjustable coolant nozzle) 	<ul style="list-style-type: none"> • No tube/hose in the work space • Reduced setup time as there are no tube/hoses to be installed 	<ul style="list-style-type: none"> • Easy handling due to clamping screw accessible from the side • Stable screw clamping

All trademarks and logos are the property of their respective companies

MODULAR-GRIP • JETCUT

Toolholder Systems for Göltebodb GWS
Multi-Spindle Machines with MODULAR-GRIP
Adaptation and Directed Internal Coolant

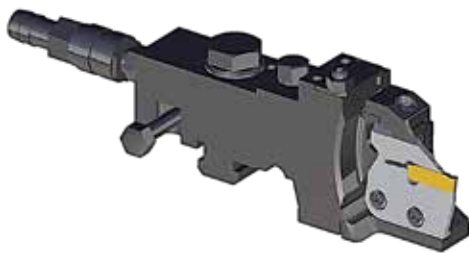

For various common multi-spindle machines such as:







Features and Benefits of Directed Internal Coolant

	Matches intermediate holders with internal coolant	Coolant connection directly from the intermediate holder	Flexible system due to different adapters
Features:			
Benefits:	<ul style="list-style-type: none"> • Low investment • Easy switching to toolholders with internal coolant 	<ul style="list-style-type: none"> • Chips do not accumulate in the work space (no coolant tube/hose required) • Reliable coolant supply due to fixed flow orientation (no adjustable coolant nozzle) • Uninterrupted work space 	<ul style="list-style-type: none"> • Variable tool length due to different adapters • Tool length can be adjusted to the travel slide

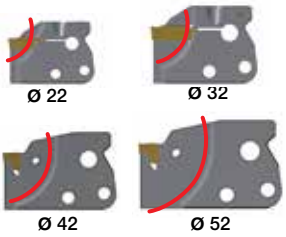
Adapters with Internal Coolant

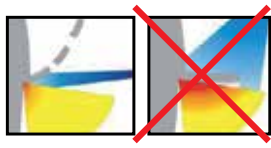
MODULAR-GRIP • JETCUT**MODULAR-GRIP Adapters
with Directed Internal Coolant**

	Extremely stable	Coolant connection from the holder into the adapter	Coolant / lubrication in the cutting zone	Vario-system
Features:	 <p>Ø 22 Ø 32 Ø 42 Ø 52</p>			 <p>TAGPAD-JHP HGPAD-JHP DGPAD-JHP CGPAD-JHP</p>
Benefits:	<ul style="list-style-type: none"> • Adapters designed for common bar diameters • Reduced vibration due to strong adapter body • Strong clamping force by screw clamping 	<ul style="list-style-type: none"> • Chips do not accumulate in the work space (no coolant tube/hose required) • No tube/hoses to be removed in case of tool breakage • Free work space 	<ul style="list-style-type: none"> • Increased tool life • Improved process safety • Better chip control 	<ul style="list-style-type: none"> • Different cutting systems can be used • Grooving and turn-groove operations can be performed with the same holder • Extremely flexible

All trademarks and logos are the property of their respective companies

Tool Selection for INDEX CNC Multi-Spindle Machines

Machine	Toolholder	Width	Adapter		Insert		Geometry / Feed	Tough ← Hard		
			DGPAD	TAGPAD	TAG	DGN		IC830	IC5400	IC808
 Index MS16	MS16-JHP	1,5 mm	DGFH MS16-1.5D16-JHP		DGN 150..J	LF 		low		
		2 mm	DGFH MS16-1.5D16-JHP		DGN 2002	MF 		•	•	•
					C 	high				
 Index MS18	MS18-22-MG-JHP	2 mm	DGPAD 2L-D22-JHP		DGN 2002	LF 		low		
						MF 		•	•	•
						C 		high		
 Index MS22	MS18-22-MG-JHP	2 mm	DGPAD 2L-D22-JHP		DGN 2002	LF 		low		
						MF 		•	•	•
						C 		high		
 Index MS32	MS32-40-MG-JHP	2 mm	DGPAD 2L-D32-JHP		DGN 2002	LF 		low		
		3,1 mm	DGPAD 3L-D32-JHP		DGN 3102	MF 		•	•	•
						C 		high		
 Index MS40	MS32-40-MG-JHP	2 mm	TAGPAD 2L-D42-JHP		TAG N2	LF 		low		
		3 mm	TAGPAD 3L-D42-JHP		TAG N3	MF 		•	•	•
C 	high									
 Index MS52	MS32-40-MG-JHP oder MS52-MG-JHP	2 mm	TAGPAD 2L-D52-JHP		TAG N2	LF 		low		
		3 mm	TAGPAD 3L-D52-JHP		TAG N3	MF 		•	•	•
C 	high									

All trademarks and logos are the property of their respective companies

Tool Selection for Göltebott GWS Systems

System Size	Max. Diameter	Width of Cut (W)	Length L	Toolholder		Adapter	Insert	Geometry / Feed	Tough ↔ Hard					
				Right Hand	Left Hand				IC830	IC5400	IC808			
 GWS02	20 mm	2 mm	51mm	MS-ES02012-GWS-MG-JHP		DGPAD 2R/ L-D20-GWS-JHP*	DGN 2002	LF		low				
			59mm	MS-ES02013-GWS-MG-JHP										
	32 mm	2 mm	59,5mm	MS-ES02012-GWS-MG-JHP		DGPAD 2R/ L-D32-JHP*		DGN 3102			MF			
			67,5mm	MS-ES02013-GWS-MG-JHP										
		3,1 mm	59,5mm	MS-ES02012-GWS-MG-JHP		DGPAD 3R/ L-D32-JHP*		DGN 3102			C			
			67,5mm	MS-ES02013-GWS-MG-JHP										

*Selection of righthand or lefthand adapter see page 502

System Size	Max. Diameter	Width of Cut (W)	Length L	Toolholder		Adapter	Insert	Geometry / Feed	Tough ↔ Hard					
				Right Hand	Left Hand				IC830	IC5400	IC808			
 GWS09	20 mm	2 mm	61mm	MS-ES09003-GWS-MG-JHP		DGPAD 2R/ L-D20-GWS-JHP*	DGN 2002	LF		low				
	32 mm	2 mm	59,5mm	MS-ES09003-GWS-MG-JHP							DGPAD 2R/ L-D32-JHP*			
		3,1 mm	59,5mm	MS-ES09003-GWS-MG-JHP		DGPAD 3R/ L-D32-JHP*		DGN 3102						
	42 mm	2 mm	62,6mm	MS-ES09003-GWS-MG-JHP		TAGPAD 2R/ L-D42-JHP*		TAG N2			MF			
		3 mm	62,4mm	MS-ES09003-GWS-MG-JHP		TAGPAD 3R/ L-D42-JHP*		TAG N3						
	52 mm	2 mm	67,6mm	MS-ES09003-GWS-MG-JHP		TAGPAD 2R/ L-D52-JHP*		TAG N2			C	high		
3 mm		67,4mm	MS-ES09003-GWS-MG-JHP		TAGPAD 3R/ L-D52-JHP*	TAG N3								
 GWS41	20 mm	2 mm	59mm	MS-ES41008-GWS-MG-JHP	MS-ES41009-GWS-MG-JHP	DGPAD 2R/ L-D20-GWS-JHP*	DGN 2002	LF		low				
	32 mm	2 mm	67,5mm	MS-ES41008-GWS-MG-JHP	MS-ES41009-GWS-MG-JHP						DGPAD 2R/ L-D32-JHP*			
		3,1 mm	67,5mm	MS-ES41008-GWS-MG-JHP	MS-ES41009-GWS-MG-JHP	DGPAD 3R/ L-D32-JHP*		DGN 3102						
	42 mm	2 mm	70,6mm	MS-ES41008-GWS-MG-JHP	MS-ES41009-GWS-MG-JHP	TAGPAD 2R/ L-D42-JHP*		TAG N2			MF			
		3 mm	70,4mm	MS-ES41008-GWS-MG-JHP	MS-ES41009-GWS-MG-JHP	TAGPAD 3R/ L-D42-JHP*		TAG N3						
	52 mm	2 mm	75,6mm	MS-ES41008-GWS-MG-JHP	MS-ES41009-GWS-MG-JHP	TAGPAD 2R/ L-D52-JHP*		TAG N2			C	high		
3 mm		75,4mm	MS-ES41008-GWS-MG-JHP	MS-ES41009-GWS-MG-JHP	TAGPAD 3R/ L-D52-JHP*	TAG N3								

*Selection of righthand or lefthand adapter see page 502

All trademarks and logos are the property of their respective companies

MS##-##-MG-JHP
 Toolholders for INDEX CNC
 Multi-Spindle Machines with
 Internal Coolant Supply for
 MODULAR-GRIP Adapters

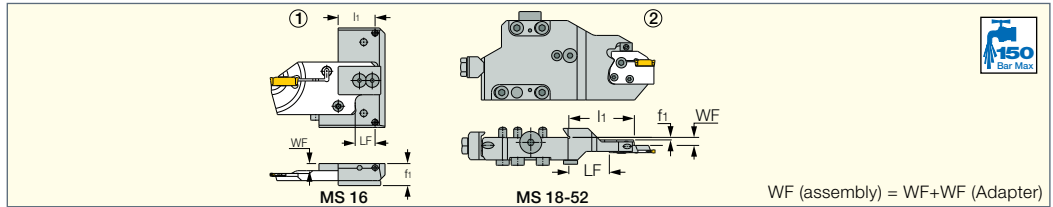

Designation	LF	l ₁	WF	f ₁	Fig.	Adapter	Adapter ₂
MS 16-JHP	14.00	26.00	5.00	15.5	1	DGFH MS16-1.5D16-JHP	-
MS 18/22-MG-JHP	46.20	67.00	13.50	8.0	2	DGPAD 2L-D22-JHP	-
MS 18/22-MG-JHP L-69.7	24.20	48.00	13.60	8.0	2	DGPAD 2L-D22-JHP	-
MS 32/40-MG-JHP	45.00	69.80	13.50	8.0	2	DGPAD 2/3L-D32-JHP	TAGPAD 2/3-D42-JHP
MS 32/40-MG-JHP-5.1	45.00	69.80	13.50	8.0	2	DGPAD 2/3L-D32-JHP	TAGPAD 2/3-D42-JHP
MS 32C-HUBVERL-MG-JHP	74.50	99.30	13.50	8.0	2	DGPAD 2/3L-D32-JHP	TAGPAD 2/3L-D32-JHP
MS 40-6/8-MG-JHP	55.00	79.80	13.50	8.0	2	TAGPAD 2/3L-D42-JHP	DGPAD 2/3L-D42-JHP
MS 40-6/8-MG-JHP-7.1	55.00	79.80	13.50	8.0	2	TAGPAD 2/3L-D42-JHP	DGPAD 2/3L-D42-JHP
MS 52-MG-JHP	46.60	-	4.50	-	2	TAGPAD 2/3-D52-JHP	-

• For user guide, see pages 496-500
 For tools, see pages: DGPAD-JHP (437) • TAGPAD-JHP (456)

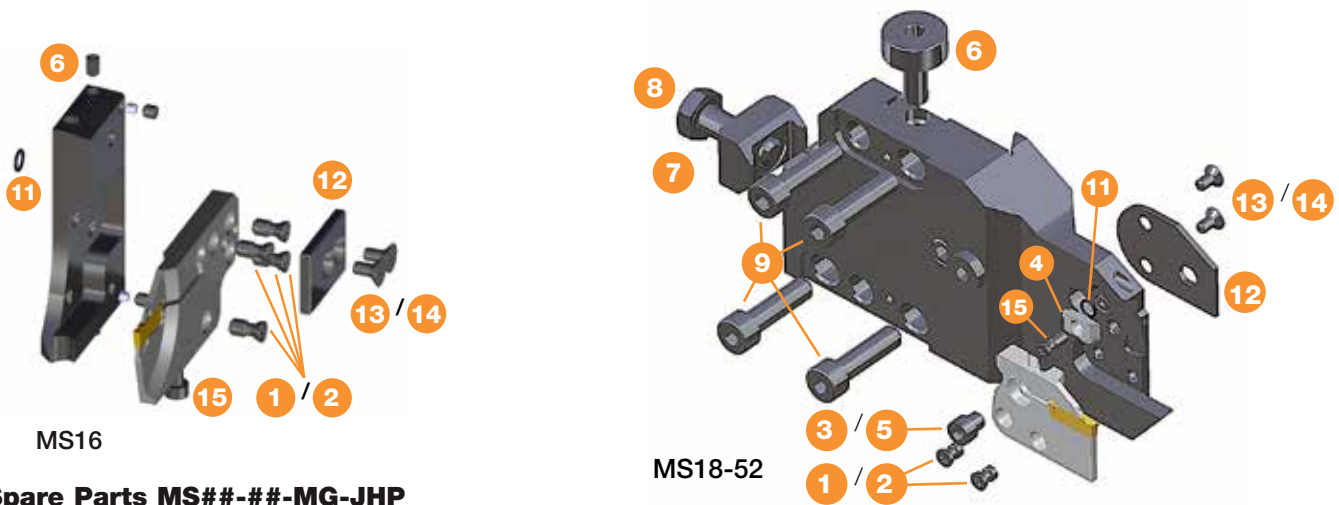

Spare Parts MS##-##-MG-JHP

No.	Designation	MS16-JHP	MS18/22-MG-JHP	MS32/40-MG-JHP
1	Screw	SR M5-04451-L10.5	SR 16-212-L7.5	SR 16-212-L7.5
2	Key	T-20/5	T-20/5	T-20/5
3	Screw		SR M6X6DIN6912-5112367	SR M6X6DIN6912-5112367
4	Wedge		KEIL 12X30DEG-5112247	KEIL 12X30DEG-5112247
5	Key		HW 5.0	HW 5.0
6	Screw	SR M4x6 DIN913 45H	WN99-08.0010.0	WN99-08.0010.0
7	Wedge		WN-11.0012.0	W00014.0017
8	ZI screw		ISO 4017-DIN 933 M8X30	ISO 4017-DIN 933 M10X30
9	Screw		SR M6X20DIN912 12.9	SR M8X30DIN912
10	Coolant Tube*		ROHR M4X1-40	ROHR M4X1-40
11	O-Ring	OR 5X1N	OR 5X1N	OR 5X1N
12	Bar stopper	W00019.0064	PLATTE-MS18-22-5112868	PLATTE-MS18-22-5112868
13	Screw	DIN7991-M4X8-8.8	DIN7991-M4X8-8.8	DIN7991-M4X8-8.8
14	Key	HW 2.5	HW 2.5	HW 2.5
15	Screw	SR M4x30DIN912	SR 34-535	SR 34-535

No.	Designation	MS32/40-MG-JHP-5.1	MS52-MG-JHP
1	Screw	SR 16-212-L7.5	SR 16-212-L7.5
2	Key	T-20/5	T-20/5
3	Screw	SR M6X6DIN6912-5112367	SR M6X6DIN6912-5112367
4	Wedge	KEIL 12X30DEG-5112247	KEIL 12X30DEG-5112247
5	Key	HW 5.0	HW 5.0
6	Screw	WN99-08.0010.0	WN99-08.0010.0
7	Wedge	W00014.0017	WN-11.0014.0
8	ZI screw	ISO 4017-DIN 933 M10X30	ISO 4017-DIN 933 M10X30
9	Screw	SR M8X30DIN912	
10	Coolant Tube*	ROHR M4X1-40	ROHR M4X1-40
11	O-Ring	OR 5X1N	OR 5X1N
12	Bar stopper	PLATTE-MS18-22-5112868	PLATTE-MS18-22-5112868*
13	Screw	DIN7991-M4X8-8.8	DIN7991-M4X8-8.8*
14	Key	HW 2.5	HW 2.5
15	Screw	SR 34-535	SR 34-535

* Optional, please order separately.

All trademarks and logos are the property of their respective companies



MS-ES####-GWS-MG-JHP

Toolholders for Goltenbodt
GWS Systems with
Internal Coolant Supply for
MODULAR-GRIP Adapters

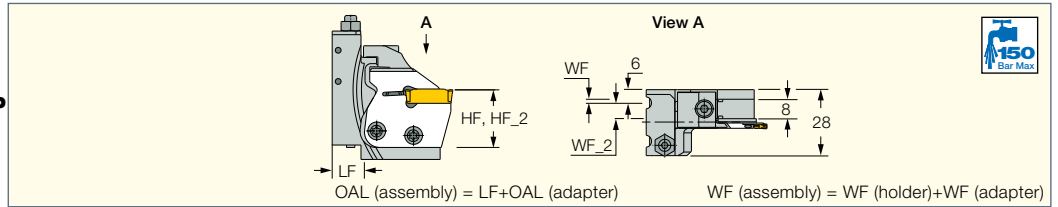

Designation	LF	WF	WF_2	HF ⁽¹⁾	HF_2 ⁽²⁾
MS-ES02012-GWS-MG-JHP	14.00	2.00	6.00	24.0	27.0
MS-ES02013-GWS-MG-JHP	22.00	2.00	6.00	24.0	27.0
MS-ES09003-GWS-MG-JHP	14.00	2.00	6.00	24.0	30.0
MS-ES41008-GWS-MG-JHP	22.00	2.00	6.00	24.0	27.0
MS-ES41009-GWS-MG-JHP	22.00	2.00	6.00	24.0	27.0

- For user guide, see pages 496-500
- ⁽¹⁾ center height adjustment for GWS43
- ⁽²⁾ center height adjustment for GWS60

For tools, see pages: DGPAD-JHP (437) • TAGPAD-JHP (456)

Wedge Selection Guide (must be ordered separately)

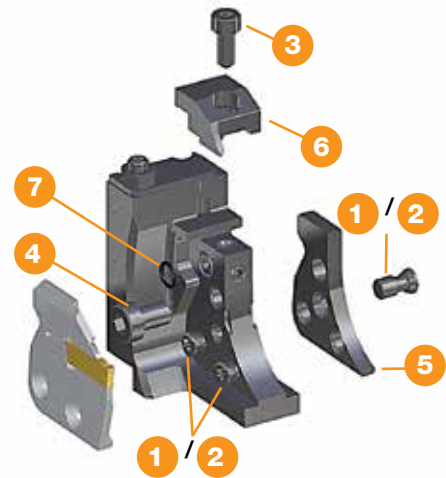
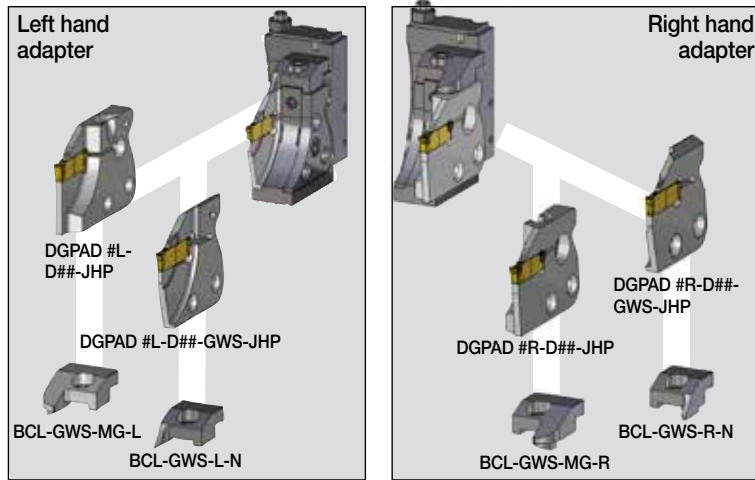

Spare Parts MS-ES####-GWS-MG-JHP

No.	Designation	MS-ES02012-GWS-MG-JHP	MS-ES02013-GWS-MG-JHP	MS-ES09003-GWS-MG-JHP	MS-ES41008-GWS-MG-JHP	MS-ES41009-GWS-MG-JHP
1	Screw	SR 16-212-L9.5	SR 16-212-L9.5	SR 16-212-L9.5	SR 16-212-L9.5	SR 16-212-L9.5
2	Key	T-20/5	T-20/5	T-20/5	T-20/5	T-20/5
3	Screw	DIN912-M4X10-12.9	DIN912-M4X10-12.9	DIN912-M4X10-12.9	DIN912-M4X10-12.9	DIN912-M4X10-12.9
4	Screw	SR M6X6-DIN6912-10.9	SR M6X6-DIN6912-10.9	SR M6X6-DIN6912-10.9	SR M6X6-DIN6912-10.9	SR M6X6-DIN6912-10.9
5	Dummy	GWS Dummy	GWS Dummy	GWS Dummy	GWS Dummy	GWS Dummy
6	Wedges*					
7	O-Ring	OR 5X1N	OR 5X1N	OR 5X1N	OR 5X1N	OR 5X1N



* Should be ordered separately

MODULAR-GRIP • JETCUT

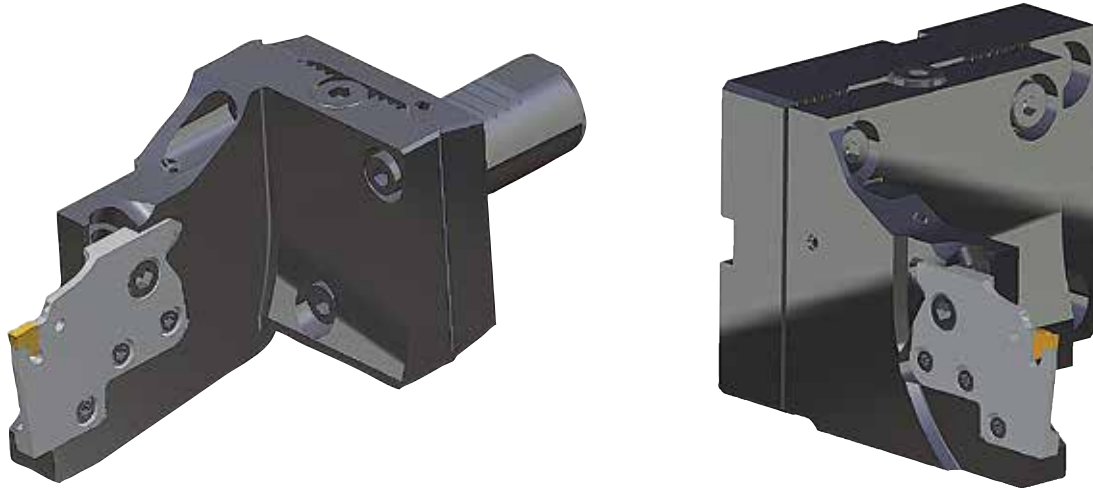
Toolholder System with Machine-Specific Adaptations for Turning Lathes

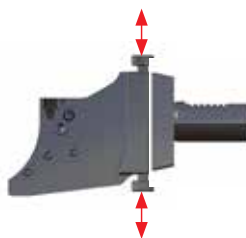

Features and Benefits of Machine-Specific Toolholder Systems

	Flexible Vario System	Adjustable Center Height	Optimized Holder Design	No Coolant Tubes / Hoses
Features:				
Benefits:	<ul style="list-style-type: none"> • Uniform intermediate holders and adapters on different machine adaptations • Low tool stock • Modular design 	<ul style="list-style-type: none"> • Optimal tool life due to adjustable center height • Reliable tool life • Turret malpositions can be balanced 	<ul style="list-style-type: none"> • Long tool life due to reduced bar overhang, less vibrations • Slim design • Low risk of collision • Suitable for any machine-specific clamping interface 	<ul style="list-style-type: none"> • Chips do not accumulate in the work space (no coolant tube / hose required) • Reliable coolant supply due to fixed flow orientation (no adjustable coolant nozzle)

System Overview

MODULAR-GRIP • JETCUT

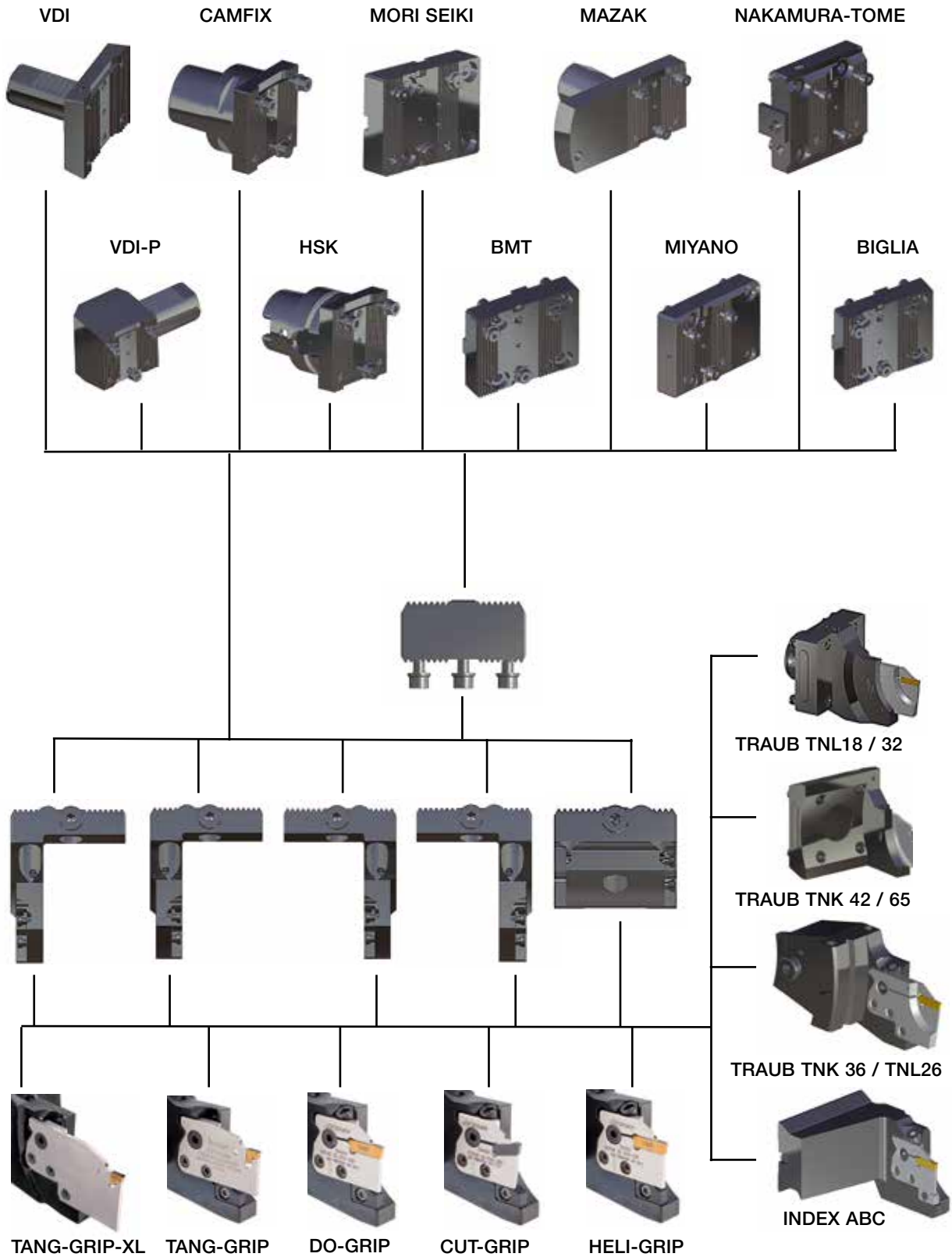

All trademarks and logos are the property of their respective companies

MODULAR-GRIP • JETCUT

Toolholder System for Star Turrets with VDI and MODULAR-GRIP-XL Adaptations and Directed Internal Coolant

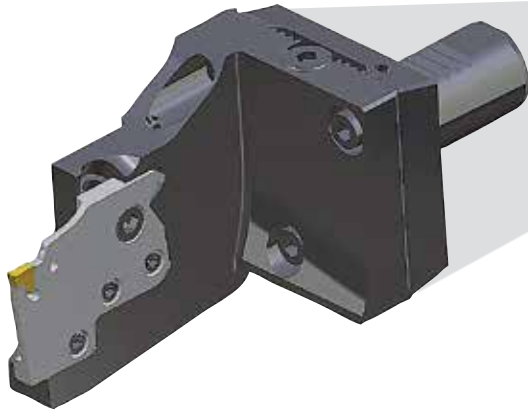

Features and Benefits of Machine-Specific Toolholder Systems

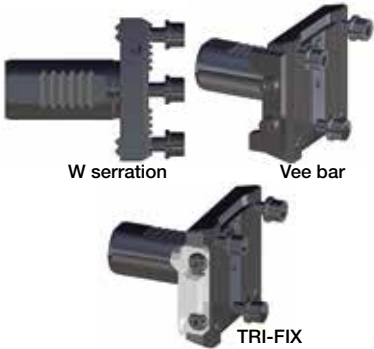
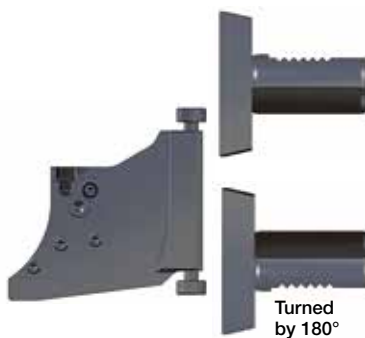
	Adaptation Sizes	Alignment Systems	VDI Shank Can Be Rotated By 180°
Features:	 <p>VDI20 VDI25</p>	 <p>W serration Vee bar</p> <p>TRI-FIX</p>	 <p>Turned by 180°</p>
Benefits:	<ul style="list-style-type: none"> • DIN69880 (ISO 10889-1) • VDI20 • VDI25 • VDI30 • VDI40 	<ul style="list-style-type: none"> • Extremely stable, torsion resistant and high-end precision 	<ul style="list-style-type: none"> • The serration can be mounted at the top or bottom • Double-serration is not necessary

MODULAR-GRIP • JETCUT

Toolholder System for Disc-Type Turrets with VDI and MODULAR-GRIP-XL Adaptations and Directed Internal Coolant

**Features and Benefits of Machine-Specific Toolholder Systems**

	Adaptation Sizes	Parting Next to Main Spindle or Sub-Spindle	Reliable Processes
Features:	<p>VDI30-P</p> <p>VDI40-P</p>		
Benefits:	<ul style="list-style-type: none"> • DIN69880 (ISO 10889-1) • VDI30-P • VDI40-P 	<ul style="list-style-type: none"> • Low risk of collision due to optimized tool design • Parting next to main spindle or sub-spindle depending on component length 	<ul style="list-style-type: none"> • Chips do not accumulate in the work space (no coolant tube / hose required) • Reliable coolant supply due to fixed flow orientation (no adjustable coolant nozzle)

All trademarks and logos are the property of their respective companies

MODULAR-GRIP • JETCUT

Toolholder System for **DOOSAN** Machines with BMT and MODULAR-GRIP-XL Adaptations and Directed Internal Coolant

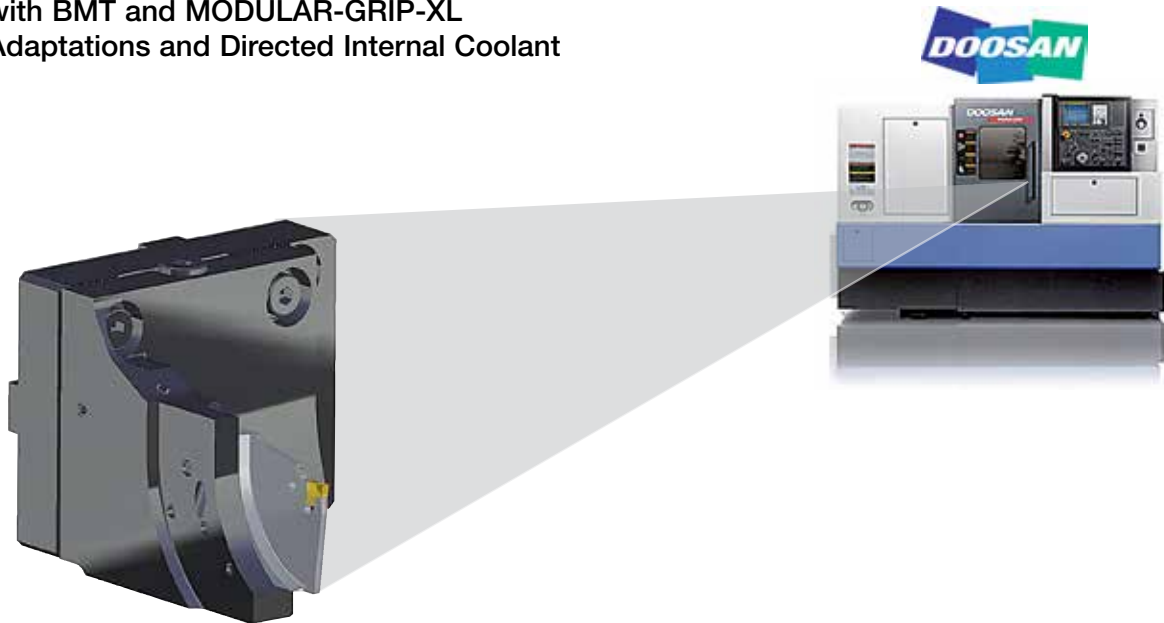

Features and Benefits of Machine-Specific Toolholder Systems

	Adaptation Sizes	Holder Turning Ability 180°	Reliable Processes
Features:	<p>BMT45 BMT55 BMT65</p>		
Benefits:	<ul style="list-style-type: none"> • BMT (Base Mounted Turret) • BMT45 • BMT55 • BMT65 	<ul style="list-style-type: none"> • Tool can be mounted on the left or right of the turret • Extremely flexible due to few elements 	<ul style="list-style-type: none"> • Chips do not accumulate in the work space (no coolant tube / hose required) • Reliable coolant supply due to fixed flow orientation (no adjustable coolant nozzle)

All trademarks and logos are the property of their respective companies

MODULAR-GRIP • JETCUT

Toolholder System for **MORI SEIKI**
Machines with MODULAR-GRIP-XL
Adaptation and Directed Internal Coolant

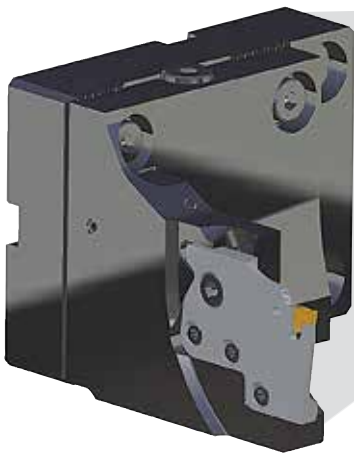
MORI SEIKI**Features and Benefits of Machine-Specific Toolholder Systems**

	Adaptation Sizes	Two Pockets for Intermediate Holders	Reliable Processes
Features:	<p>MORI40 MORI60</p> <p>Ø 40 Ø 60</p>	<p>(For MORI60)</p> <p>1. pocket next to (main) spindle 2. pocket next to (sub-) spindle</p>	
Benefits:	<p>Mori Seike turrets for NZ machines</p> <ul style="list-style-type: none"> • MORI40 • For NL machines • MORI60 	<ul style="list-style-type: none"> • Intermediate holder can be mounted on the left or right side of the turret • Modular flexibility due to few elements 	<ul style="list-style-type: none"> • Chips do not accumulate in the work space (no coolant tube/hose required) • Reliable coolant supply due to fixed flow orientation (no adjustable coolant nozzle)

All trademarks and logos are the property of their respective companies

MODULAR-GRIP • JETCUT

Toolholder System for **MAZAK** Machines with MODULAR-GRIP-XL Adaptation and Directed Internal Coolant

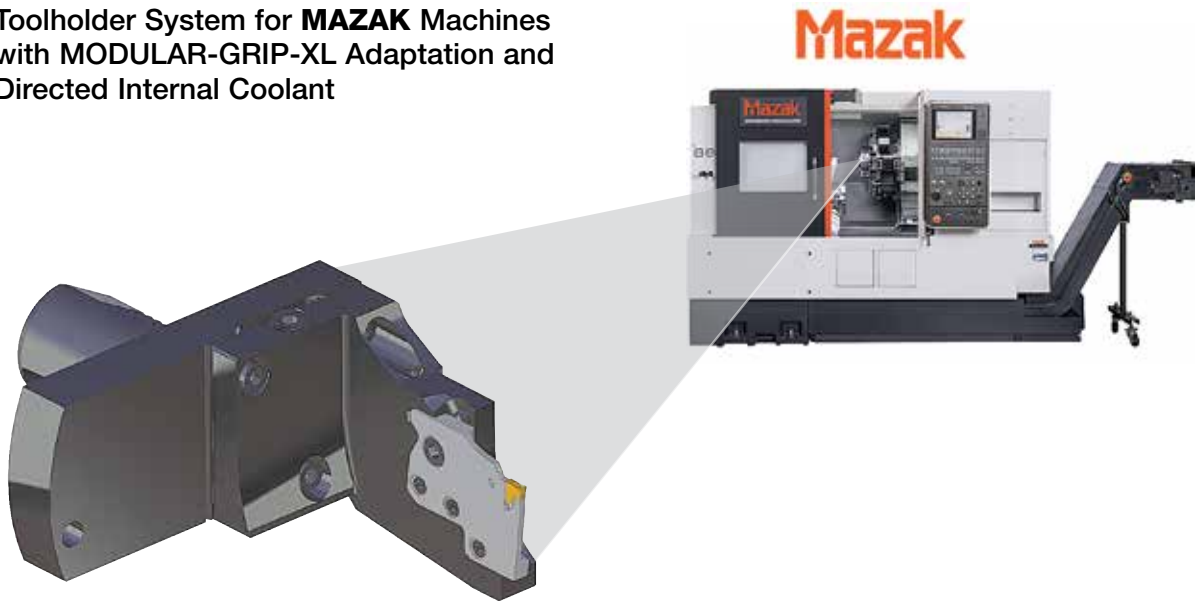

Features and Benefits of Machine-Specific Toolholder Systems

	Adaptation Sizes	Adaptation Features	Reliable Processes
Features:	<p>MA4016E MA4020E MA4020T MA5020E MA4016T</p>	<p>MA####E MA####T</p>	
Benefits:	<p>For Mazak Quick Turn, Hyper Quardrex and Multiplex machines</p> <ul style="list-style-type: none"> • MA4016E • MA4020E • MA5020E • MA4016T • MA4020T 	<ul style="list-style-type: none"> • Suitable for any common Mazak adaptations 	<ul style="list-style-type: none"> • Chips do not accumulate in the work space (no coolant tube / hose required) • Reliable coolant supply due to fixed flow orientation (no adjustable coolant nozzle)

All trademarks and logos are the property of their respective companies

MODULAR-GRIP • JETCUT

Toolholder System for Machines with **CAMFIX** MODULAR-GRIP-XL Adaptations and Directed Internal Coolant

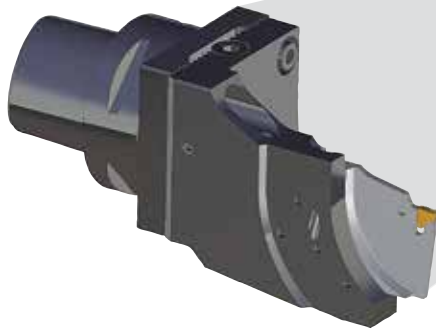

Features and Benefits of Machine-Specific Toolholder Systems

	Adaptation Sizes	Parting Next to Main Spindle and Sub-Spindle	Reliable Processes
Features:	<p>C4 C5 C6</p>		
Benefits:	<p>For CAMFIX turrets and for turn-mill centers with a CAMFIX ISO26623-1 milling spindle</p> <ul style="list-style-type: none"> • C4 • C5 • C6 	<ul style="list-style-type: none"> • Low risk of collision due to optimized tool design • Parting next to main spindle or sub-spindle depending on the component length 	<ul style="list-style-type: none"> • Chips do not accumulate in the work space (no coolant tube / hose required) • Reliable coolant supply due to fixed flow orientation (no adjustable coolant nozzle)

All trademarks and logos are the property of their respective companies

MODULAR-GRIP • JETCUT

Toolholder Systems for Turn-Mill Centers with HSK Shank and MODULAR-GRIP-XL Adaptation and Directed Internal Coolant

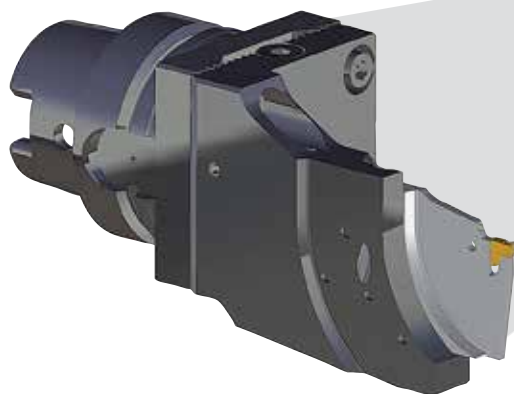

Features and Benefits of Machine-Specific Toolholder Systems

	Adaptation Sizes	Relief for Automatic Tool Changers	Reliable Processes
Features:	<p>HSK T 40</p> <p>HSK T 63</p>	<p>Relief for tool exchanger</p>	
Benefits:	<p>For HSK T turrets and for turn-mill centers with HSK T milling spindles</p> <ul style="list-style-type: none"> • HSK T 40 • HSK T 63 	<ul style="list-style-type: none"> • Tools can be used on machines with an automatic tool exchanger 	<ul style="list-style-type: none"> • Chips do not accumulate in the work space (no coolant tube / hose required) • Reliable coolant supply due to fixed flow orientation (no flexible coolant nozzle)



MODULAR-GRIP • JETCUT

Toolholder Systems for **BIGLIA**, **MIYANO**
and **NAKAMURA TOME** with
MODULAR-GRIP-XL Adaptation and
Directed internal Coolant

Toolholder systems for BIGLIA, MIYANO and NAKAMURA TOME

  Holder for BIGLIA turrets <ul style="list-style-type: none"> • BI40 • BI55 	  Holder for MIYANO turrets <ul style="list-style-type: none"> • MI40 • MI45 • MI55 	 Nakamura-Tome  Holder for NAKAMURA-TOME turrets <ul style="list-style-type: none"> • NT55 • NT65
--	--	---

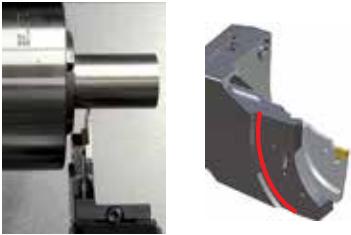
Features and Benefits of Machine-Specific Toolholder Systems

	Optimized Holder Design	Parting Next to Main Spindle and Sub-Spindle	Reliable Processes
Features:			
Benefits:	<ul style="list-style-type: none"> • Long tool life due to small bar overhang and less vibrations • Slim design • Low risk of collision • Suitable for any machine-specific clamping devices 	<ul style="list-style-type: none"> • Low risk of collision due to optimized tool design • Parting next to main spindle or sub-spindle depending on the correspondent length 	<ul style="list-style-type: none"> • Chips do not accumulate in the work space (no coolant tube / hose required) • Reliable coolant supply due to fixed flow orientation (no adjustable coolant nozzle)



All trademarks and logos are the property of their respective companies

MODULAR-GRIP • JETCUT

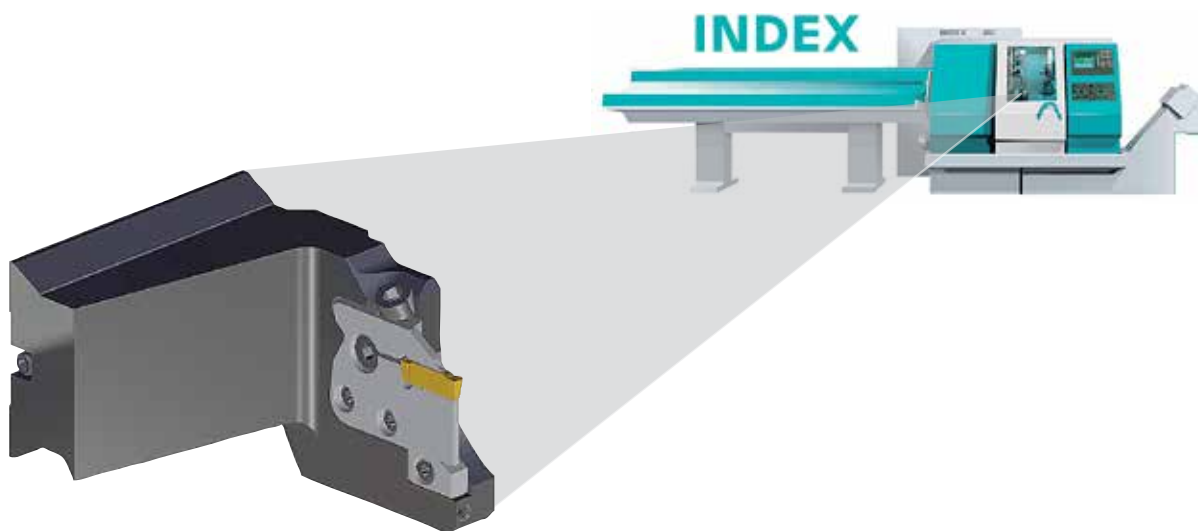
Toolholder System for INDEX ABC
Machines with MODULAR-GRIP-XL
Adaptation and Directed Internal Coolant

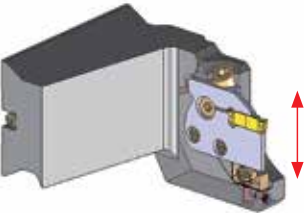

Features and Benefits of Machine-Specific Toolholder Systems

	Adaptation Sizes	Height Adjustment +0.2 mm	Machine Optimized Tool Design
Features:			
Benefits:	<p>For INDEX ABC machines turret 2</p> <ul style="list-style-type: none"> • Prismatic adaptation 	<ul style="list-style-type: none"> • Mismatch of turrets can be adjusted • Extremely long tool life due to exact center height 	<ul style="list-style-type: none"> • Extremely long tool life due to very stable tool design • Reduced vibrations due to reduced bar overhang • Reliable coolant supply due to fixed flow orientation (no adjustable coolant nozzle)

All trademarks and logos are the property of their respective companies

MODULAR-GRIP • JETCUT

Toolholder System for Integral Shank 45
with MODULAR-GRIP-XL Adaptation and
Directed Internal Coolant

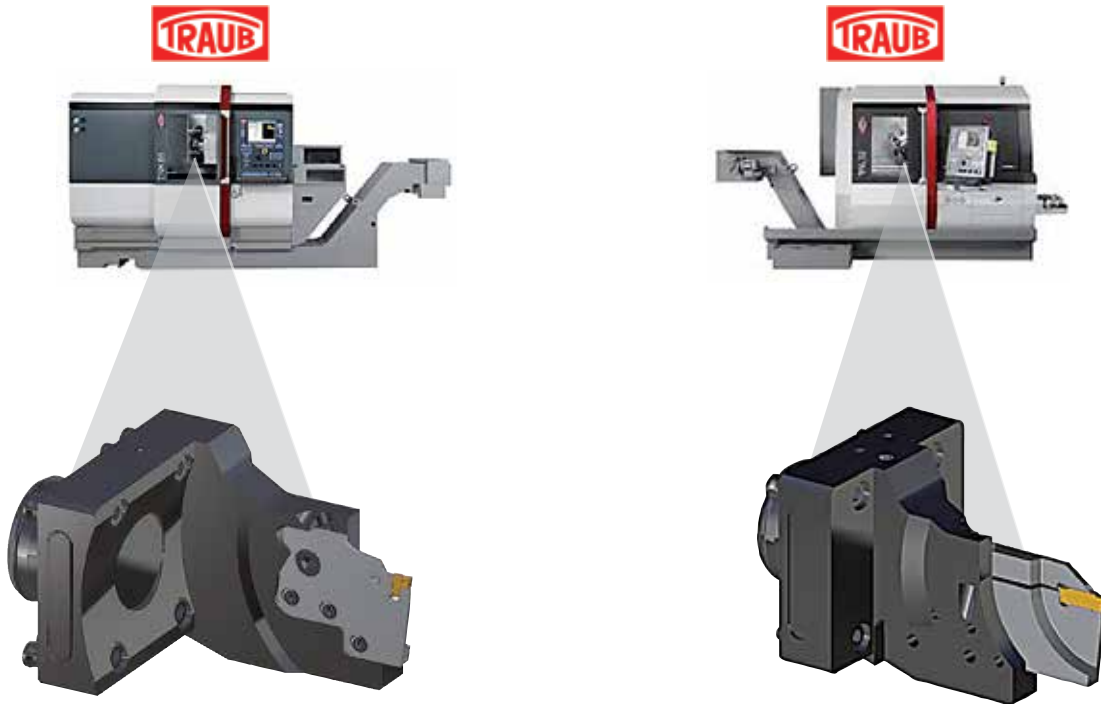
**Features and Benefits of Machine-Specific Toolholder Systems**

	TNK 36 / TNL 26	TNL 18 / TNL 32	TNK 42 / TNK 65
Features:			
Benefits:	<p>Dovetail connection for TRAUB TNK36 and TNL26 Machines</p> <ul style="list-style-type: none"> • Tools are suitable for parting and grooving applications • Suitable for any machine-specific clamping device 	<ul style="list-style-type: none"> • Integral shank 45 for Traub TNL18 and TNL32 • Tools are suitable for parting and grooving applications • Suitable for any grooving systems with directed internal coolant 	<ul style="list-style-type: none"> • Low risk of collision due to machine-specific tool design • Tool is suitable for parting and grooving applications • Suitable for any machine-specific clamping device

All trademarks and logos are the property of their respective companies



Adapters with internal coolant

MODULAR-GRIP • JETCUT

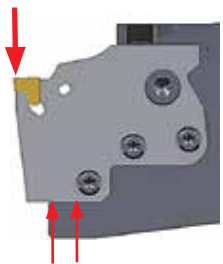
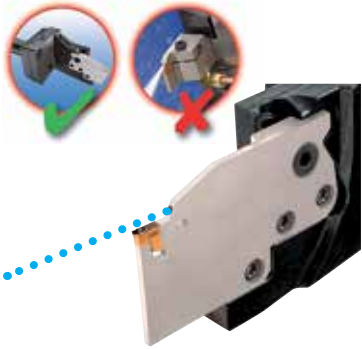
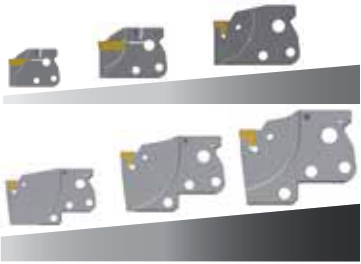
Features and Benefits of Machine-Specific Toolholder Systems

	Extremely Stable	Coolant Directly to the Cutting Zone	Additional External Diameters
Features:			
Benefits:	<ul style="list-style-type: none"> • Very long tool life as the cutting forces are directly transmitted to the intermediate holder • Very rigid due to additional clamping screw in the MODULAR-GRIP-XL adapters pocket • Less vibrations due to rigid tool design 	<ul style="list-style-type: none"> • Reliable tool life due to fixed flow orientation (no adjustable coolant nozzle) • Chips do not accumulate in the work space (no coolant tube / hose required) • Very efficient due to small distance between coolant exit and cutting zone 	<ul style="list-style-type: none"> • Long tool life due to reduced vibrations by reinforced tool body • Suitable for all popular bar diameters

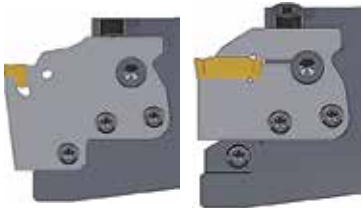
Features and Benefits of Machine-Specific Toolholder Systems

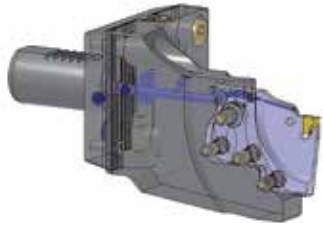
	MODULAR-GRIP/ MODULAR-GRIP-XL	Vario System	Coolant Connection From the Turret into the Cutting Zone
Features:		 <p>TAGPAD-JHP TAGPAD-XL-JHP HGPAD-JHP DGPAD-JHP CGPAD-JHP</p>	
Benefits:	<ul style="list-style-type: none"> • Very flexible due to compatibility with existing adapter systems • MODULAR-GRIP and MODULAR-GRIP-XL adapters can be mounted • High rigidity using MODULAR-GRIP adapters by additional support 	<ul style="list-style-type: none"> • Very flexible • Suitable for any JHP grooving systems • Direct cooling for grooving and turn-groove operations • A variety of options with a single holder 	<ul style="list-style-type: none"> • Fast set-up, less downtime • Chips do not accumulate in the work space • Easy handling, low risk of error

All trademarks and logos are the property of their respective companies

Tool Design - Overview

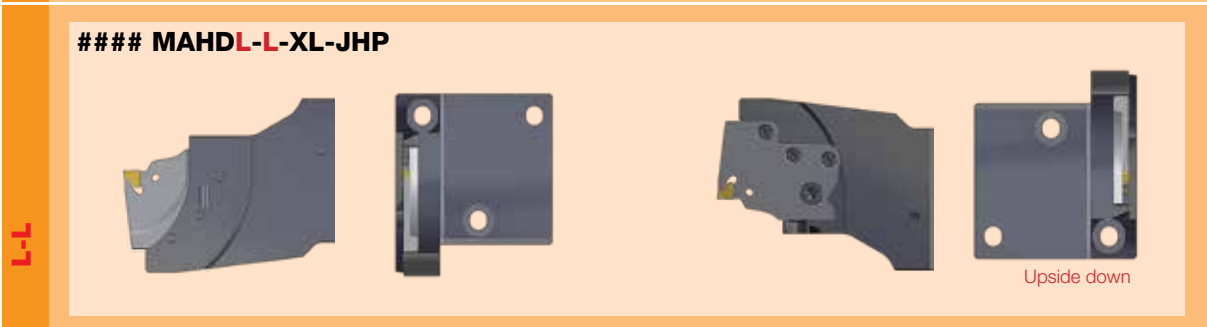
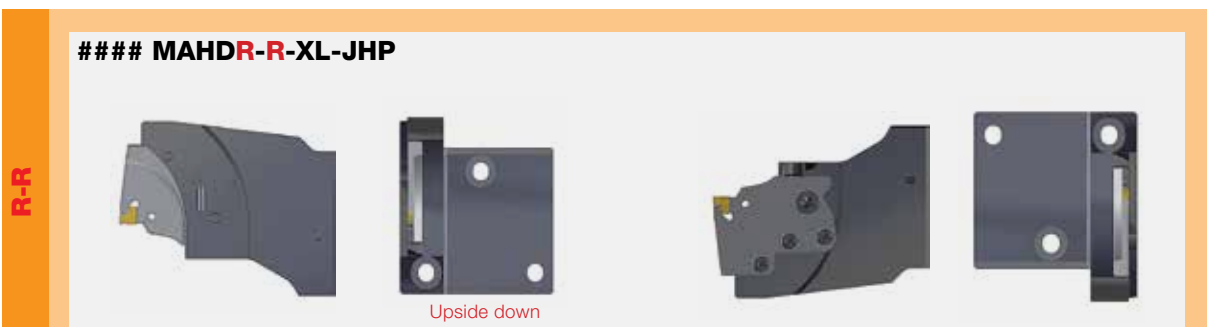

Tool Selection

Example:

VDI30MAHDR-LXL-JHP

Machine interface

Turning direction at the main spindle

Position of the adapter pocket

1. Defined Machine Adaptations

Type	Machine Adaptations											
	VDI	VDI with W-serration	VDI with Vee-bar	VDI for disc type turret	BMT	MORI SEIKI	MAZAK	CAMFIX	HSK T	Biglia	Miyano	Nakamura-Tome
Size	VDI20	VDI25W	VDI25V	VDI30-P	BMT45	MORI40	MA4016E	C4	HSK T 40	BI40	MI40	NT45
	VDI25	VDI30W	VDI30V	VDI40-P	BMT55	MORI60	MA4020E	C5	HSK T 63	BI55	MI45	NT55
	VDI30	VDI40W	VDI40V		BMT65		MA5020E	C6			MI55	NT65
	VDI40						MA4016T					
							MA4020T					

For details on adaptation please see technical information (starting at page 518).

2. Defined Turning Direction at the Main Spindle

View through the spindle into the work space

Right-Turn Direction M3 in CNC program



Left-Turn Direction M4 in CNC program



3. Position of the Adapter Pocket

Adapter on the Right

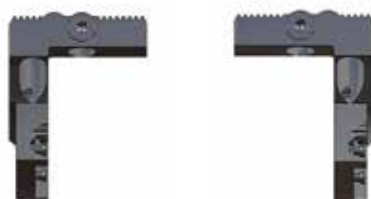

Adapter on the Left

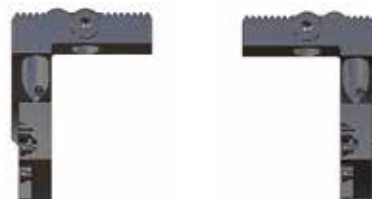

VDI MODULAR-GRIP**VDI#### MAHD#-#-XL-JHP**

Toolholders for Star Turrets
with VDI Adaptation and
Internal Coolant Supply for
MODULAR-GRIP-XL Adapters

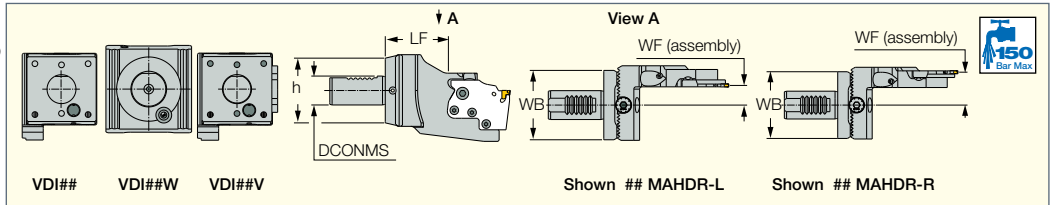

Designation	DCONMS	WF	LF	h	WB	Align.	Holder	Holder ₂
VDI20 MAHD-L-XL-JHP	20.00	29.60	70.60	56.0	60.00	-	VDI20 V60-JHP	V60 MAHD-L-XL-JHP
VDI25 MAHD-L-XL-JHP	25.00	29.60	54.60	61.2	60.00	-	VDI25 V60-JHP	V60 MAHD-L-XL-JHP
VDI25TF MAHD-L-XL-JHP	25.00	29.60	54.60	61.2	96.00	TriFix	VDI25 V60-JHP	V60 MAHD-L-XL-JHP
VDI25V MAHD-L-XL-JHP	25.00	29.60	54.60	61.2	74.00	V-Bar	VDI25 V60-JHP	V60 MAHD-L-XL-JHP
VDI25W MAHD-L-XL-JHP	25.00	29.60	54.60	61.2	60.00	W-toothing	VDI25W V60-JHP	V60 MAHD-L-XL-JHP
VDI30-MAHD-L-XL-JHP	30.00	29.60	54.60	66.0	70.00	-	VDI30 V60-JHP	V60 MAHD-L-XL-JHP
VDI30TF MAHD-L-XL-JHP	30.00	29.60	54.60	66.0	106.00	TriFix	VDI30 V60-JHP	V60 MAHD-L-XL-JHP
VDI30V MAHD-L-XL-JHP	30.00	29.60	54.60	66.0	86.00	V-Bar	VDI30 V60-JHP	V60 MAHD-L-XL-JHP
VDI30W MAHD-L-XL-JHP	30.00	29.60	54.60	70.0	66.00	W-toothing	VDI30W V60-JHP	V60 MAHD-L-XL-JHP
VDI40 MAHD-L-XL-JHP	40.00	38.10	58.60	85.0	82.00	-	VDI40 V85-JHP	V85 MAHD-L-XL-JHP
VDI40TF MAHD-L-XL-JHP	40.00	38.10	58.60	85.0	118.00	TriFix	VDI40 V85-JHP	V85 MAHD-L-XL-JHP
VDI40V MAHD-L-XL-JHP	40.00	38.10	58.60	85.0	98.00	V-Bar	VDI40 V85-JHP	V85 MAHD-L-XL-JHP
VDI40W MAHD-L-XL-JHP	40.00	38.10	58.60	85.0	82.00	W-toothing	VDI40W V85-JHP	V85 MAHD-L-XL-JHP
VDI20 MAHD-R-XL-JHP	20.00	17.00	70.60	56.0	60.00	-	VDI20 V60-JHP	V60 MAHD-R-XL-JHP
VDI25 MAHD-R-XL-JHP	25.00	17.00	54.60	61.2	60.00	-	VDI25 V60-JHP	V60 MAHD-R-XL-JHP
VDI25TF MAHD-R-XL-JHP	25.00	17.00	54.60	61.2	96.00	TriFix	VDI25 V60-JHP	V60 MAHD-R-XL-JHP
VDI25V MAHD-R-XL-JHP	25.00	17.00	54.60	61.2	74.00	V-Bar	VDI25 V60-JHP	V60 MAHD-R-XL-JHP
VDI25W MAHD-R-XL-JHP	25.00	17.00	54.60	61.2	60.00	W-toothing	VDI25W V60-JHP	V60 MAHD-R-XL-JHP
VDI30-MAHD-R-XL-JHP	30.00	17.00	54.60	66.0	70.00	-	VDI30 V60-JHP	V60 MAHD-R-XL-JHP
VDI30TF MAHD-R-XL-JHP	30.00	17.00	54.60	66.0	106.00	TriFix	VDI30 V60-JHP	V60 MAHD-R-XL-JHP
VDI30V MAHD-R-XL-JHP	30.00	17.00	54.60	66.0	86.00	V-Bar	VDI30 V60-JHP	V60 MAHD-R-XL-JHP
VDI30W MAHD-R-XL-JHP	30.00	17.00	54.60	70.0	66.00	W-toothing	VDI30W V60-JHP	V60 MAHD-R-XL-JHP
VDI40 MAHD-R-XL-JHP	40.00	25.50	58.60	85.0	82.00	-	VDI40 V85-JHP	V85 MAHD-R-XL-JHP
VDI40TF MAHD-R-XL-JHP	40.00	25.50	58.60	85.0	118.00	TriFix	VDI40 V85-JHP	V85 MAHD-R-XL-JHP
VDI40V MAHD-R-XL-JHP	40.00	25.50	58.60	85.0	98.00	V-Bar	VDI40 V85-JHP	V85 MAHD-R-XL-JHP
VDI40W MAHD-R-XL-JHP	40.00	25.50	58.60	85.0	82.00	W-toothing	VDI40W V85-JHP	V85 MAHD-R-XL-JHP
VDI20 MAHDR-L-XL-JHP	20.00	17.00	70.60	56.0	60.00	-	VDI20 V60-JHP	V60 MAHDR-L-XL-JHP
VDI25 MAHDR-L-XL-JHP	25.00	17.00	54.60	61.2	60.00	-	VDI25 V60-JHP	V60 MAHDR-L-XL-JHP
VDI25TF MAHDR-L-XL-JHP	25.00	17.00	54.60	61.2	96.00	TriFix	VDI25 V60-JHP	V60 MAHDR-L-XL-JHP
VDI25V MAHDR-L-XL-JHP	25.00	17.00	54.60	61.2	74.00	V-Bar	VDI25 V60-JHP	V60 MAHDR-L-XL-JHP
VDI25W MAHDR-L-XL-JHP	25.00	17.00	54.60	61.2	60.00	W-toothing	VDI25W V60-JHP	V60 MAHDR-L-XL-JHP
VDI30-MAHDR-L-XL-JHP	30.00	17.00	54.60	66.0	70.00	-	VDI30 V60-JHP	V60 MAHDR-L-XL-JHP
VDI30TF MAHDR-L-XL-JHP	30.00	17.00	54.60	66.0	106.00	TriFix	VDI30 V60-JHP	V60 MAHDR-L-XL-JHP
VDI30V MAHDR-L-XL-JHP	30.00	17.00	54.60	66.0	86.00	V-Bar	VDI30 V60-JHP	V60 MAHDR-L-XL-JHP
VDI30W MAHDR-L-XL-JHP	30.00	17.00	54.60	70.0	66.00	W-toothing	VDI30W V60-JHP	V60 MAHDR-L-XL-JHP
VDI40 MAHDR-L-XL-JHP	40.00	25.50	58.60	85.0	82.00	-	VDI40 V85-JHP	V85 MAHDR-L-XL-JHP
VDI40TF MAHDR-L-XL-JHP	40.00	25.50	58.60	85.0	118.00	TriFix	VDI40 V85-JHP	V85 MAHDR-L-XL-JHP
VDI40V MAHDR-L-XL-JHP	40.00	25.50	58.60	85.0	98.00	V-Bar	VDI40 V85-JHP	V85 MAHDR-L-XL-JHP
VDI40W MAHDR-L-XL-JHP	40.00	25.50	58.60	85.0	82.00	W-toothing	VDI40W V85-JHP	V85 MAHDR-L-XL-JHP
VDI20 MAHDR-R-XL-JHP	20.00	29.60	70.60	56.0	60.00	-	VDI20 V60-JHP	V60 MAHDR-R-XL-JHP
VDI25 MAHDR-R-XL-JHP	25.00	29.60	54.60	61.2	60.00	-	VDI25 V60-JHP	V60 MAHDR-R-XL-JHP
VDI25TF MAHDR-R-XL-JHP	25.00	29.60	54.60	61.2	96.00	TriFix	VDI25 V60-JHP	V60 MAHDR-R-XL-JHP
VDI25V MAHDR-R-XL-JHP	25.00	29.60	54.60	61.2	74.00	V-Bar	VDI25 V60-JHP	V60 MAHDR-R-XL-JHP
VDI25W MAHDR-R-XL-JHP	25.00	29.60	54.60	61.2	60.00	W-toothing	VDI25W V60-JHP	V60 MAHDR-R-XL-JHP
VDI30 MAHDR-R-XL-JHP	30.00	29.60	54.60	66.0	70.00	-	VDI30 V60-JHP	V60 MAHDR-R-XL-JHP
VDI30TF MAHDR-R-XL-JHP	30.00	29.60	54.60	66.0	106.00	TriFix	VDI30 V60-JHP	V60 MAHDR-R-XL-JHP
VDI30V MAHDR-R-XL-JHP	30.00	29.60	54.60	66.0	86.00	V-Bar	VDI30 V60-JHP	V60 MAHDR-R-XL-JHP
VDI30W MAHDR-R-XL-JHP	30.00	29.60	54.60	70.0	66.00	W-toothing	VDI30W V60-JHP	V60 MAHDR-R-XL-JHP
VDI40-MAHDR-R-XL-JHP	40.00	38.10	58.60	85.0	82.00	-	VDI40 V85-JHP	V85 MAHDR-R-XL-JHP
VDI40TF MAHDR-R-XL-JHP	40.00	38.10	58.60	85.0	118.00	TriFix	VDI40 V85-JHP	V85 MAHDR-R-XL-JHP
VDI40V MAHDR-R-XL-JHP	40.00	38.10	58.60	85.0	98.00	V-Bar	VDI40 V85-JHP	V85 MAHDR-R-XL-JHP
VDI40W MAHDR-R-XL-JHP	40.00	38.10	58.60	85.0	82.00	W-toothing	VDI40W V85-JHP	V85 MAHDR-R-XL-JHP

For tools, see pages: DGPAD-JHP (437) • TAGPAD-JHP (456) • TAGPAD-XL-JHP (456)

• For user guide, see pages 503-517

Holder Spare Parts

Designation	(1) Screw	(2) Shim
VDI20 MAHD#-#-XL-JHP	SR M6x16DIN912 12.9	ISO 7091 WASHER 6X12
VDI25 MAHD#-#-XL-JHP	SR M6x16DIN912 12.9	ISO 7091 WASHER 6X12
VDI30 MAHD#-#-XL-JHP	SR M6x16DIN912 12.9	ISO 7091 WASHER 6X12
VDI40 MAHD#-#-XL-JHP	DIN7984-M8X20-8.8	ISO 7091 WASHER 8X16

For intermediate holder spare parts see page 530.



All trademarks and logos are the property of their respective companies

VDI#### MAHD#-#-XL-JHP Tool Dimensions with Adapter

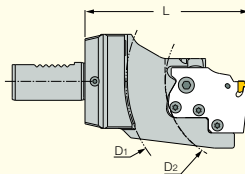

L = Total tool length
D₁ = max. diameter of sub-spindle

Adapter	VDI20			VDI25			VDI30			VDI40		
	L	D ₁	D ₂	L	D ₁	D ₂	L	D ₁	D ₂	L	D ₁	D ₂
DGPAD ...-D22-JHP	93,1	99	46	100,1	147	94	101,1	147	94	104,1	147	94
DGPAD ...-D32-JHP	93,1	99	46	100,1	147	94	101,1	147	94	104,1	147	94
TAGPAD ...-D42-JHP	96	104	52	103	152	100	104	152	100	107	152	100
TAGPAD ...-D52-JHP	101	114	62	108	162	110	109	162	110	112	162	110
TAGPAD-XL ...-D52-JHP	101	114	62	108	162	110	109	162	110	112	162	110
TAGPAD-XL ...-D65-JHP	107,6	127	70	114,6	175	118	115,6	175	118	118,6	175	118
TAGPAD-XL ...-D82-JHP	117,6	146	86	124,6	194	134	125,6	194	134	128,6	194	134
TAGPAD-XL ...-D102-JHP	130,6	170	107	137,6	218	155	138,6	218	155	141,6	218	155

VDI MODULAR-GRIP

VDI###-P MAHD#-#-XL-JHP

Turrets with VDI Adaptation and Internal Coolant Supply for MODULAR-GRIP-XL Adapters

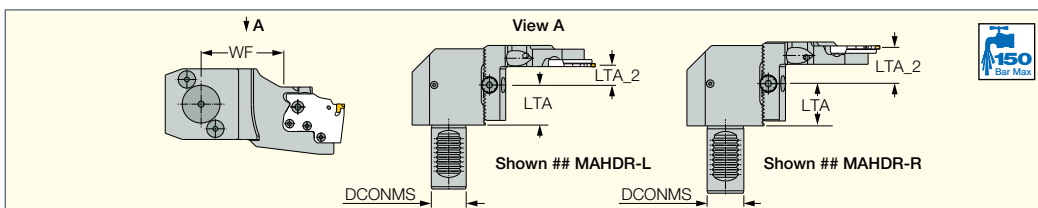

Designation	DCONMS	WF	LTA	LTA_2	Holder	Holder 2
VDI30-P MAHDL-L-XL-JHP	30.00	72.60	34.50	29.60	VDI30-P V60-JHP	V60 MAHDL-L-XL-JHP
VDI40-P MAHDL-L-XL-JHP	40.00	76.60	34.50	29.60	VDI40-P V60-JHP	V60 MAHDL-L-XL-JHP
VDI30-P MAHDL-R-XL-JHP	30.00	72.60	34.50	17.00	VDI30-P V60-JHP	V60 MAHDL-R-XL-JHP
VDI40-P MAHDL-R-XL-JHP	40.00	76.60	34.50	17.00	VDI40-P V60-JHP	V60 MAHDL-R-XL-JHP
VDI30-P MAHDR-L-XL-JHP	30.00	72.60	34.50	17.00	VDI30-P V60-JHP	V60 MAHDR-L-XL-JHP
VDI40-P MAHDR-L-XL-JHP	40.00	76.60	34.50	17.00	VDI40-P V60-JHP	V60 MAHDR-L-XL-JHP
VDI30-P MAHDR-R-XL-JHP	30.00	72.60	34.50	29.60	VDI30-P V60-JHP	V60 MAHDR-R-XL-JHP
VDI40-P MAHDR-R-XL-JHP	40.00	76.60	34.50	29.60	VDI40-P V60-JHP	V60 MAHDR-R-XL-JHP

For tools, see pages: DGPAD-JHP (437) • TAGPAD-JHP (456) • TAGPAD-XL-JHP (456)

• For user guide, see pages 503-517

Holder Spare Parts

Designation	(1) Screw	(2) Shim
VDI30-P MAHD#-#-XL-JHP	SR M6x16DIN912 12.9	ISO 7091 WASHER 6X12
VDI40-P MAHD#-#-XL-JHP	SR M6x16DIN912 12.9	ISO 7091 WASHER 6X12

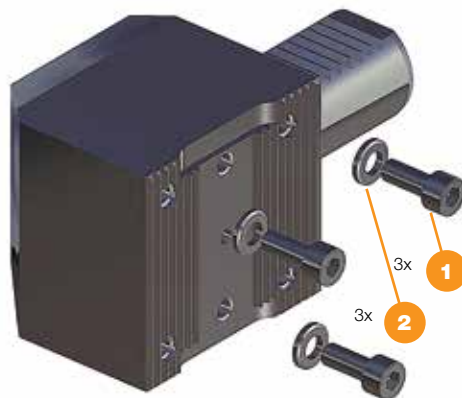

Tool Dimensions with Adapter

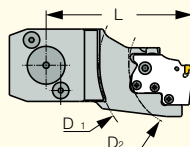

L = Total tool length
D₁ = Max. diameter of sub-spindle

Adapter	VDI30-P			VDI40-P		
	L	D ₁	D ₂	L	D ₁	D ₂
DGPAD ...-D22-JHP	118,1	147	94	122,1	147	94
DGPAD ...-D32-JHP	118,1	147	94	122,1	147	94
TAGPAD ...-D42-JHP	121	152	100	125	152	100
TAGPAD ...-D52-JHP	126	162	110	130	162	110
TAGPAD-XL ...-D52-JHP	126	162	110	130	162	110
TAGPAD-XL ...-D65-JHP	132,6	175	118	136,6	175	118
TAGPAD-XL ...-D82-JHP	142,6	194	134	146,6	194	134
TAGPAD-XL ...-D102-JHP	155,6	218	155	159,6	218	155

All trademarks and logos are the property of their respective companies

BMT## MAHD##-#-XL-JHP
 Toolholders for BMT Turrets
 with Internal Coolant Supply for
 MODULAR-GRIP-XL Adapters

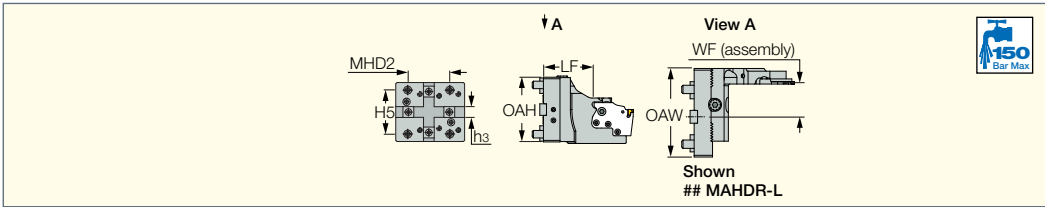

Designation	OAH	OAW	H ₅	MHD ₂	h ₃ ⁽¹⁾	LF	WF	Holder	Holder 2
BMT45 MAHDL-L-XL-JHP	77.0	95.00	58.00	58.0	15.0	60.60	53.10	BMT45 V85-JHP	V85 MAHDL-L-XL-JHP
BMT55 MAHDL-L-XL-JHP	84.0	103.50	64.00	64.0	15.0	63.60	52.10	BMT55 V85-JHP	V85 MAHDL-L-XL-JHP
BMT65 MAHDL-L-XL-JHP	98.0	114.50	73.00	70.0	18.0	68.60	55.10	BMT65 V85-JHP	V85 MAHDL-L-XL-JHP
BMT75 MAHDL-L-XL-JHP	112.0	120.00	90.00	90.0	25.0	72.10	58.10	BMT75 V85-JHP	V85 MAHDL-L-XL-JHP
BMT45 MAHDL-R-XL-JHP	77.0	95.00	58.00	58.0	15.0	60.60	40.50	BMT45 V85-JHP	V85 MAHDL-R-XL-JHP
BMT55 MAHDL-R-XL-JHP	84.0	103.50	64.00	64.0	15.0	63.60	39.50	BMT55 V85-JHP	V85 MAHDL-R-XL-JHP
BMT65 MAHDL-R-XL-JHP	98.0	114.50	73.00	70.0	18.0	68.60	42.50	BMT65 V85-JHP	V85 MAHDL-R-XL-JHP
BMT75 MAHDL-R-XL-JHP	112.0	120.00	90.00	90.0	25.0	72.10	45.50	BMT75 V85-JHP	V85 MAHDL-R-XL-JHP
BMT45 MAHDR-L-XL-JHP	77.0	95.00	58.00	58.0	15.0	60.60	40.50	BMT45 V85-JHP	V85 MAHDR-L-XL-JHP
BMT55 MAHDR-L-XL-JHP	84.0	103.50	64.00	64.0	15.0	63.60	39.50	BMT55 V85-JHP	V85 MAHDR-L-XL-JHP
BMT65 MAHDR-L-XL-JHP	98.0	114.50	73.00	70.0	18.0	68.60	42.50	BMT65 V85-JHP	V85 MAHDR-L-XL-JHP
BMT75 MAHDR-L-XL-JHP	112.0	120.00	90.00	90.0	25.0	72.10	45.50	BMT75 V85-JHP	V85 MAHDR-L-XL-JHP
BMT45 MAHDR-R-XL-JHP	77.0	95.00	58.00	58.0	15.0	60.60	53.10	BMT45 V85-JHP	V85 MAHDR-R-XL-JHP
BMT55 MAHDR-R-XL-JHP	84.0	103.50	64.00	64.0	15.0	63.60	52.10	BMT55 V85-JHP	V85 MAHDR-R-XL-JHP
BMT65 MAHDR-R-XL-JHP	98.0	114.50	73.00	70.0	18.0	68.60	55.10	BMT65 V85-JHP	V85 MAHDR-R-XL-JHP
BMT75 MAHDR-R-XL-JHP	112.0	120.00	90.00	90.0	25.0	72.10	58.10	BMT75 V85-JHP	V85 MAHDR-R-XL-JHP

⁽¹⁾ Slot Nut

For tools, see pages: DGPAD-JHP (437) • TAGPAD-JHP (456) • TAGPAD-XL-JHP (456)
 • For user guide, see pages 503-517

Holder Spare Parts

Designation	(1) Screw	(2) Screw	(3) Shim	(4) Slot Nuts	(5) Screw	(6) O-Ring
BMT45 MAHD##-#-XL-JHP	SR M10x20DIN912 12.9	DIN7984-M8X20-8.8	ISO 7091 WASHER 8X16	NS 20x8.7x15	DIN912 XM 5X10	OR 7x1.5xPERBUNAN
BMT55 MAHD##-#-XL-JHP	SR M10x20DIN912 12.9	DIN7984-M8X20-8.8	ISO 7091 WASHER 8X16	NS 20x8.7x15	DIN912 XM 5X10	OR 7x1.5xPERBUNAN
BMT65 MAHD##-#-XL-JHP	SR M12X25	DIN7984-M8X20-8.8	ISO7091 WASHER 8X16	NS 18x10x18	DIN912 XM 6X12	OR 9x1.5xPERBUNAN

Tool Dimensions with Adapter

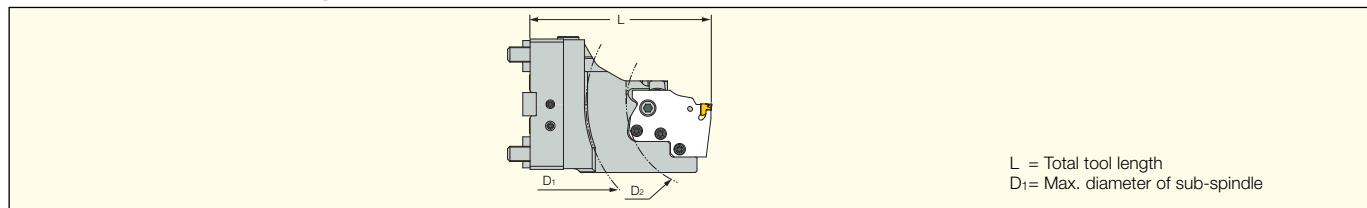

Adapter	BMT45			BMT55			BMT65		
	L	D ₁	D ₂	L	D ₁	D ₂	L	D ₁	D ₂
DGPAD ...-D22-JHP	106,1	147	94	109,1	147	94	114,1	147	94
DGPAD ...-D32-JHP	106,1	147	94	109,1	147	94	114,1	147	94
TAGPAD ...-D42-JHP	109	152	100	112	152	100	117	152	100
TAGPAD ...-D52-JHP	114	162	110	117	162	110	122	162	110
TAGPAD-XL ...-D52-JHP	114	162	110	117	162	110	122	162	110
TAGPAD-XL ...-D65-JHP	120,6	175	118	123,6	175	118	128,6	175	118
TAGPAD-XL ...-D82-JHP	130,6	194	134	133,6	194	134	138,6	194	134
TAGPAD-XL ...-D102-JHP	143,6	218	155	146,6	218	155	151,6	218	155

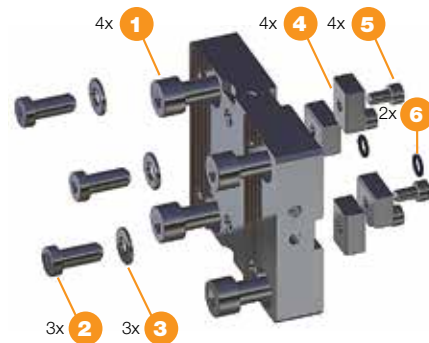

All trademarks and logos are the property of their respective companies

MORI## MAHD#-#-XL-JHP
 Toolholders for MORI SEIKI Turrets
 with Internal Coolant Supply for
 MODULAR-GRIP-XL Adapters

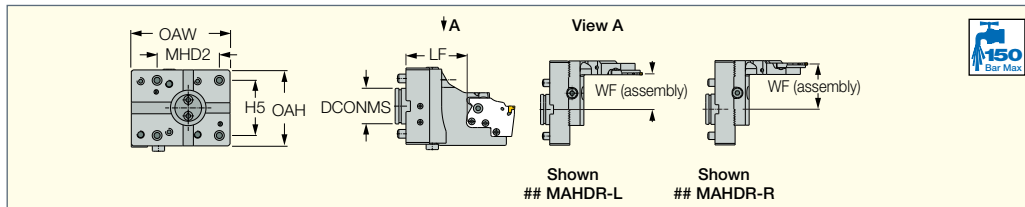

Designation	OAH	OAW	H5	MHD2	DCONMS	LF	WF	Holder	Holder 2
MORI40 MAHDL-L-XL-JHP	83.0	111.00	61.00	70.0	39.90	68.60	59.60	MORI40 V85-JHP	V85 MAHDL-L-XL-JHP
MORI60 MAHDL-L-XL-JHP	109.3	172.00	84.00	94.0	59.90	72.10	100.60	MORI60 V85-JHP	V85 MAHDL-L-XL-JHP
MORI40 MAHDR-L-XL-JHP	83.0	111.00	61.00	70.0	39.90	68.60	47.00	MORI40 V85-JHP	V85 MAHDR-L-XL-JHP
MORI60 MAHDR-L-XL-JHP	109.3	172.00	84.00	94.0	59.90	72.10	50.00	MORI60 V85-JHP	V85 MAHDR-L-XL-JHP
MORI40 MAHDR-R-XL-JHP	83.0	111.00	61.00	70.0	39.90	68.60	59.60	MORI40 V85-JHP	V85 MAHDR-R-XL-JHP
MORI60 MAHDR-R-XL-JHP	109.3	172.00	84.00	94.0	59.90	72.10	62.60	MORI60 V85-JHP	V85 MAHDR-R-XL-JHP

For tools, see pages: DGPAD-JHP (437) • TAGPAD-JHP (456) • TAGPAD-XL-JHP (456)
 • For user guide, see pages 503-517

Holder Spare Parts

Designation	(1) Screw	(2) Screw	(3) Shim	(4) Shank	(5) Screw
MORI40 MAHD#-#-XL-JHP	SR M10x20DIN912 12.9	DIN7984-M8X20-8.8	ISO 7091 WASHER 8X16	SS-40NZBMT	SR M6X25DIN912 12.9U
MORI60 MAHD#-#-XL-JHP	SR M12x25	DIN7984-M8X20-8.8	ISO 7091 WASHER 8X16	SS-60NLBMT	SR M8X25DIN912

For intermediate holder spare parts see page 530.

Tool Dimensions with Adapter

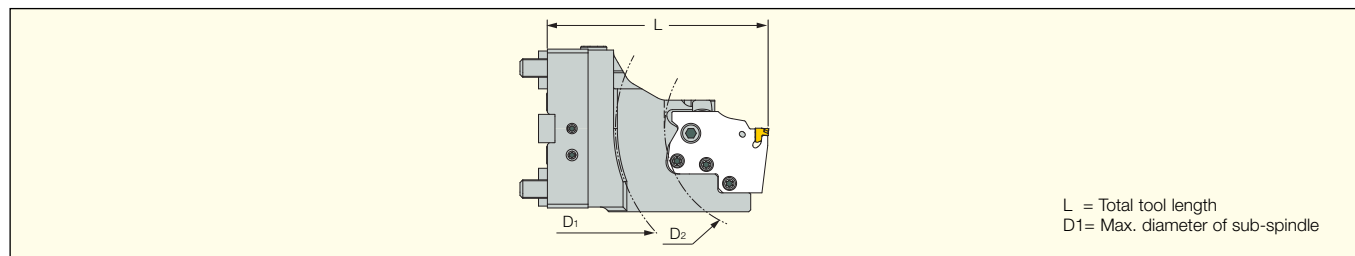

Adapter	MORI40			MORI60		
	L	D1	D2	L	D1	D2
DGPAD ...-D22-JHP	114,1	147	94	117,6	147	94
DGPAD ...-D32-JHP	114,1	147	94	117,6	147	94
TAGPAD ...-D42-JHP	117	152	100	120,5	152	100
TAGPAD ...-D52-JHP	122	162	110	125,5	162	110
TAGPAD-XL ...-D52-JHP	122	162	110	125,5	162	110
TAGPAD-XL ...-D65-JHP	128,6	175	118	132,1	175	118
TAGPAD-XL ...-D82-JHP	138,6	194	134	142,1	194	134
TAGPAD-XL ...-D102-JHP	151,6	218	155	155,6	218	155

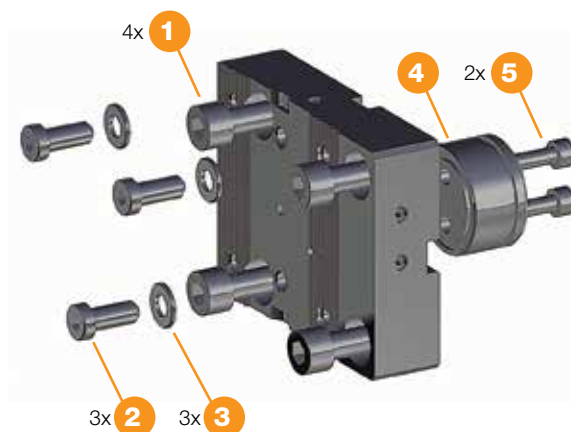

MA#### MAHD#-#-XL-JHP
Toolholders for Mazak Turrets with Internal Coolant Supply for MODULAR-GRIP-XL Adapters

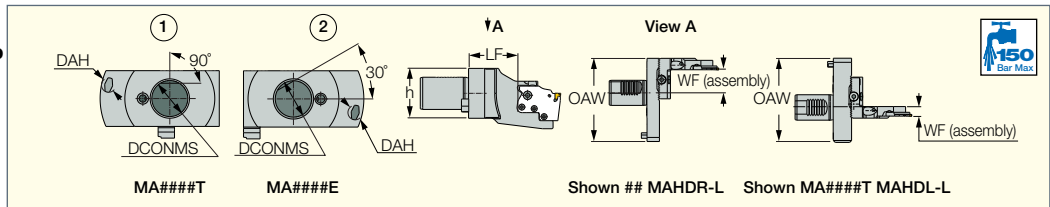

Designation	DCONMS	DAH	Fig	h	OAW	LF	WF	Holder	Holder 2
MA4016T MAHD-L-XL-JHP	40.00	16.00	1	62.0	132.50	70.00	13.90	MA4016T V60-JHP	V60 MAHD-L-XL-JHP
MA4020T MAHD-L-XL-JHP	40.00	20.00	1	62.0	137.50	70.00	13.90	MA4020T V60-JHP	V60 MAHD-L-XL-JHP
MA4016T MAHD-R-XL-JHP	40.00	16.00	1	62.0	132.50	70.00	1.30	MA4016T V60-JHP	V60 MAHD-R-XL-JHP
MA4020T MAHD-R-XL-JHP	40.00	20.00	1	62.0	137.50	70.00	1.30	MA4020T V60-JHP	V60 MAHD-R-XL-JHP
MA4016T MAHDR-L-XL-JHP	40.00	16.00	1	62.0	132.50	70.00	34.20	MA4016T V60-JHP	V60 MAHDR-L-XL-JHP
MA4020T MAHDR-L-XL-JHP	40.00	20.00	1	62.0	137.50	70.00	34.20	MA4020T V60-JHP	V60 MAHDR-L-XL-JHP
MA4016T MAHDR-R-XL-JHP	40.00	16.00	1	62.0	132.50	70.00	45.30	MA4016T V60-JHP	V60 MAHDR-R-XL-JHP
MA4020T MAHDR-R-XL-JHP	40.00	20.00	1	62.0	137.50	70.00	45.30	MA4020T V60-JHP	V60 MAHDR-R-XL-JHP
MA4016E MAHD-L-XL-JHP	40.00	16.00	2	62.0	162.50	71.10	21.40	MA4016E V60-JHP	V60 MAHD-L-XL-JHP
MA4020E MAHD-L-XL-JHP	40.00	20.00	2	62.0	170.00	71.10	21.40	MA4020E V60-JHP	V60 MAHD-L-XL-JHP
MA5020E MAHD-L-XL-JHP	50.00	20.00	2	100.0	168.50	88.70	2.90	MA5020E V85-JHP	V85 MAHD-L-XL-JHP
MA4016E MAHD-R-XL-JHP	40.00	16.00	2	62.0	162.50	71.10	34.00	MA4016E V60-JHP	V60 MAHD-R-XL-JHP
MA4020E MAHD-R-XL-JHP	40.00	20.00	2	62.0	170.00	71.10	34.00	MA4020E V60-JHP	V60 MAHD-R-XL-JHP
MA5020E MAHD-R-XL-JHP	50.00	20.00	2	100.0	168.50	88.70	15.50	MA5020E V85-JHP	V85 MAHD-R-XL-JHP
MA4016E MAHDR-L-XL-JHP	40.00	16.00	2	62.0	162.50	71.10	68.00	MA4016E V60-JHP	V60 MAHDR-L-XL-JHP
MA4020E MAHDR-L-XL-JHP	40.00	20.00	2	62.0	170.00	71.10	68.00	MA4020E V60-JHP	V60 MAHDR-L-XL-JHP
MA5020E MAHDR-L-XL-JHP	50.00	20.00	2	100.0	168.50	88.70	66.50	MA5020E V85-JHP	V85 MAHDR-L-XL-JHP
MA4016E MAHDR-R-XL-JHP	40.00	16.00	2	62.0	162.50	71.10	80.60	MA4016E V60-JHP	V60 MAHDR-R-XL-JHP
MA4020E MAHDR-R-XL-JHP	40.00	20.00	2	62.0	170.00	71.10	80.60	MA4020E V60-JHP	V60 MAHDR-R-XL-JHP
MA5020E MAHDR-R-XL-JHP	50.00	20.00	2	100.0	168.50	88.70	79.10	MA5020E V85-JHP	V85 MAHDR-R-XL-JHP

For tools, see pages: DGPAD-JHP (437) • TAGPAD-JHP (456) • TAGPAD-XL-JHP (456)
• For user guide, see pages 503-517

Holder Spare Parts

Designation	(1) Screw	(2) Shim	(3) Positioning pin	(4) O-Ring
MA4016E MAHD#-#-XL-JHP	SR M6x16DIN912 12.9	ISO 7091 WASHER 6X12	FB10001 16x9x24	OR 9x2xPERBUNAN
MA4020E MAHD#-#-XL-JHP	SR M6x16DIN912 12.9	ISO 7091 WASHER 6X12	FB12001 20x15x27	OR 9x2xPERBUNAN
MA5020E MAHD#-#-XL-JHP	DIN7984-M8X20-8.8	ISO 7091 WASHER 8X16	FB12001 20x15x27	AS-ABSTREIFER 10x16x3X4.5 N359 NBR 90
MA4016T MAHD#-#-XL-JHP	SR M6x16DIN912 12.9	ISO 7091 WASHER 6X12	FB10001 16x9x24	OR 9x2xPERBUNAN
MA4020T MAHD#-#-XL-JHP	SR M6x16DIN912 12.9	ISO 7091 WASHER 6X12	FB12001 20x15x27	OR 9x2xPERBUNAN

For intermediate holder spare parts see page 530.

Tool Dimensions with Adapter

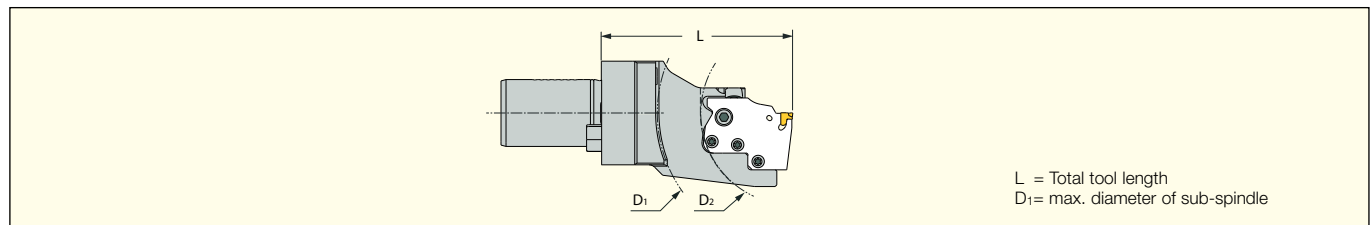

Adapter	MA40###			MA5020E		
	L	D1	D2	L	D1	D2
DGPAD ...-D22-JHP	116,6	147	94	134,1	147	94
DGPAD ...-D32-JHP	116,6	147	94	134,1	147	94
TAGPAD ...-D42-JHP	119,5	152	100	137	152	100
TAGPAD ...-D52-JHP	124,5	162	110	142	162	110
TAGPAD-XL ...-D52-JHP	124,5	162	110	142	162	110
TAGPAD-XL ...-D65-JHP	131,1	175	118	148,6	175	118
TAGPAD-XL ...-D82-JHP	141,1	194	134	158,6	194	134
TAGPAD-XL ...-D102-JHP	154,6	218	155	171,6	218	155

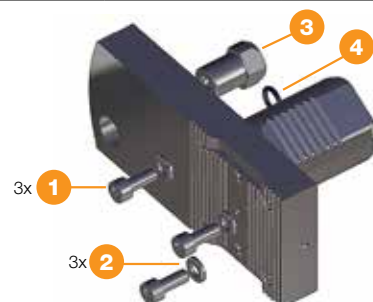

All trademarks and logos are the property of their respective companies

C# MAHD#-#-XL-JHP

Toolholders for CAMFIX
Adaptations with Internal
Coolant Supply for
MODULAR-GRIP-XL Adapters

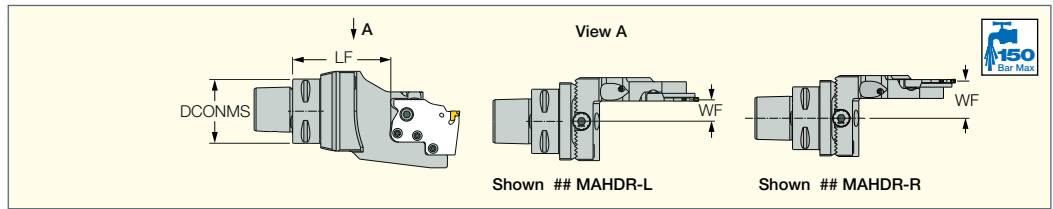

Designation	DCONMS	LF	WF	Holder	Holder 2
C4 MAHDL-L-XL-JHP	40.00	76.40	29.60	C4 V60-JHP	V60 MAHDL-L-XL-JHP
C5 MAHDL-L-XL-JHP	50.00	76.40	29.60	C5 V60-JHP	V60 MAHDL-L-XL-JHP
C6 MAHDL-L-XL-JHP	63.00	78.40	29.60	C6 V60-JHP	V60 MAHDL-L-XL-JHP
C4 MAHDL-R-XL-JHP	40.00	76.40	17.00	C4 V60-JHP	V60 MAHDL-R-XL-JHP
C5 MAHDL-R-XL-JHP	50.00	76.40	17.00	C5 V60-JHP	V60 MAHDL-R-XL-JHP
C6 MAHDL-R-XL-JHP	63.00	78.40	17.00	C6 V60-JHP	V60 MAHDL-R-XL-JHP
C4 MAHDR-L-XL-JHP	40.00	76.40	17.00	C4 V60-JHP	V60 MAHDR-L-XL-JHP
C5 MAHDR-L-XL-JHP	50.00	76.40	17.00	C5 V60-JHP	V60 MAHDR-L-XL-JHP
C6 MAHDR-L-XL-JHP	63.00	78.40	17.00	C6 V60-JHP	V60 MAHDR-L-XL-JHP
C4 MAHDR-R-XL-JHP	40.00	76.40	29.60	C4 V60-JHP	V60 MAHDR-R-XL-JHP
C5 MAHDR-R-XL-JHP	50.00	76.40	29.60	C5 V60-JHP	V60 MAHDR-R-XL-JHP
C6 MAHDR-R-XL-JHP	63.00	78.40	29.60	C6 V60-JHP	V60 MAHDR-R-XL-JHP

For tools, see pages: DGPAD-JHP (437) • TAGPAD-JHP (456) • TAGPAD-XL-JHP (456)

• For user guide, see pages 503-517

Holder Spare Parts

Designation	(1) Screw	(2) Shim
C4 MAHD#-#-XL-JHP	SR M6x16DIN912 12.9	ISO 7091 WASHER 6X12
C5 MAHD#-#-XL-JHP	SR M6x16DIN912 12.9	ISO 7091 WASHER 6X12
C6 MAHD#-#-XL-JHP	SR M6x16DIN912 12.9	ISO 7091 WASHER 6X12

For intermediate holder spare parts see page 530.

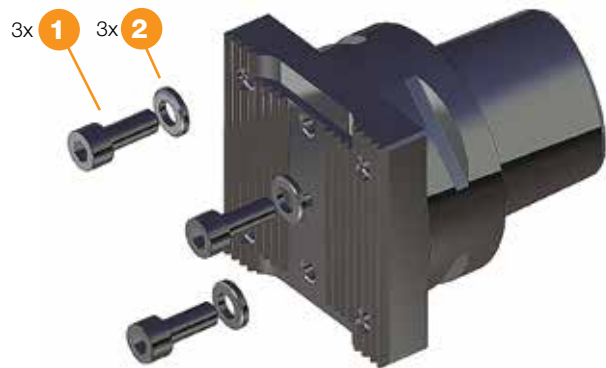

Tool Dimensions with Adapter

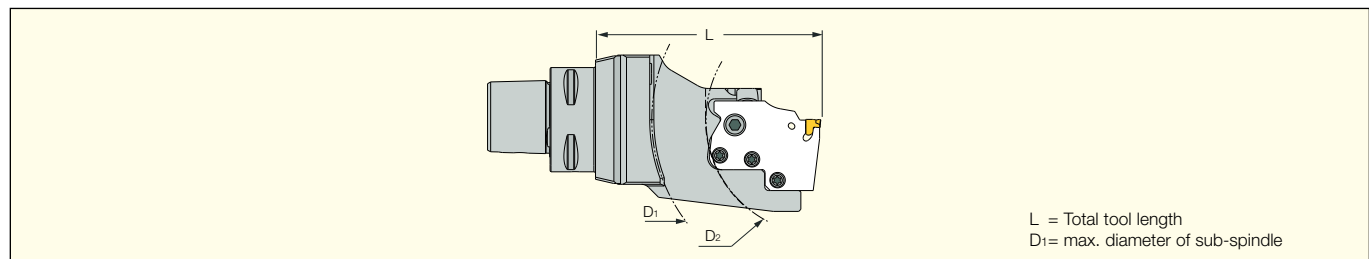

Adapter	C4			C5			C6		
	L	D1	D2	L	D1	D2	L	D1	D2
DGPAD ...-D22-JHP	121,9	147	94	121,9	147	94	123,9	147	94
DGPAD ...-D32-JHP	121,9	147	94	121,9	147	94	123,9	147	94
TAGPAD ...-D42-JHP	124,8	152	100	124,8	152	100	126,8	152	100
TAGPAD ...-D52-JHP	129,8	162	110	129,8	162	110	131,8	162	110
TAGPAD-XL ...-D52-JHP	129,8	162	110	129,8	162	110	131,8	162	110
TAGPAD-XL ...-D65-JHP	136,4	175	118	136,4	175	118	138,4	175	118
TAGPAD-XL ...-D82-JHP	146,4	194	134	146,4	194	134	148,4	194	134
TAGPAD-XL ...-D102-JHP	159,4	218	155	159,4	218	155	161,4	218	155

MODULAR-GRIP HSK

HSK T ## MAHD#-#-XL-JHP

Toolholders for HSK-T
Adaptations with Internal
Coolant Supply for
MODULAR-GRIP-XL Adapters

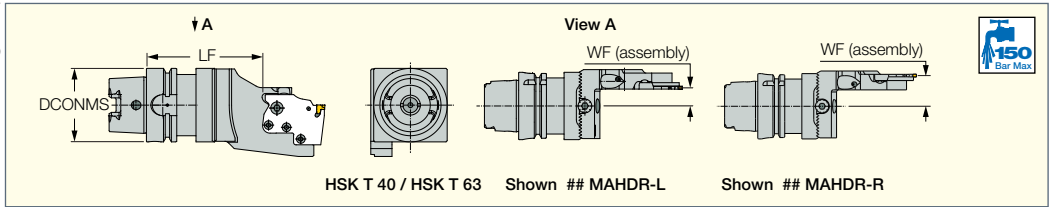

Designation	DCONMS	LF	WF	Holder	Holder 2
HSK T 40 MAHDL-L-XL-JHP	40.00	99.60	29.60	HSK T 40 V60-JHP	V60 MAHDL-L-XL-JHP
HSK T 63 MAHDL-L-XL-JHP	63.00	99.60	29.60	HSK T 63 V60-JHP	V60 MAHDL-L-XL-JHP
HSK T 40 MAHDL-R-XL-JHP	40.00	99.60	17.00	HSK T 40 V60-JHP	V60 MAHDL-R-XL-JHP
HSK T 63 MAHDL-R-XL-JHP	63.00	99.60	17.00	HSK T 63 V60-JHP	V60 MAHDL-R-XL-JHP
HSK T 40 MAHDR-L-XL-JHP	40.00	99.60	17.00	HSK T 40 V60-JHP	V60 MAHDR-L-XL-JHP
HSK T 63 MAHDR-L-XL-JHP	63.00	99.60	17.00	HSK T 63 V60-JHP	V60 MAHDR-L-XL-JHP
HSK T 40 MAHDR-R-XL-JHP	40.00	99.60	29.60	HSK T 40 V60-JHP	V60 MAHDR-R-XL-JHP
HSK T 63 MAHDR-R-XL-JHP	63.00	99.60	29.60	HSK T 63 V60-JHP	V60 MAHDR-R-XL-JHP

For tools, see pages: DGPAD-JHP (437) • TAGPAD-JHP (456) • TAGPAD-XL-JHP (456)
• For user guide, see pages 503-517

Holder Spare Parts

Designation	(1) Screw	(2) Shim
HSK T 40 MAHD#-#-XL-JHP	SR M6x16DIN912 12.9	ISO 7091 WASHER 6X12
HSK T 63 MAHD#-#-XL-JHP	SR M6x16DIN912 12.9	ISO 7091 WASHER 6X12

For intermediate holder spare parts see page 530.

Tool Dimensions with Adapter

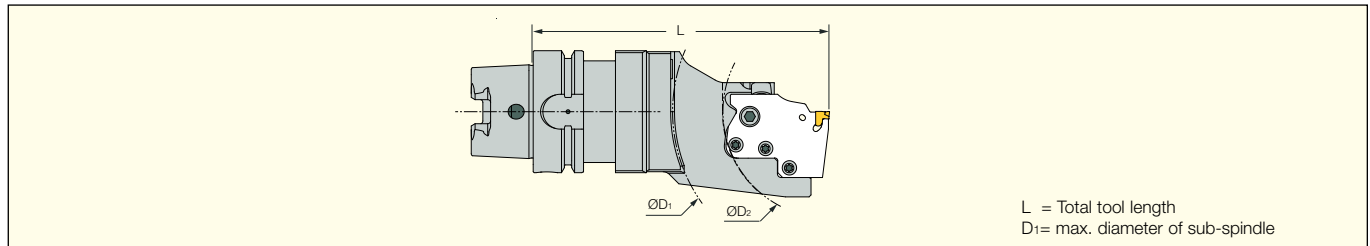

Adapter	HSK T 40			HSK T 63		
	L	D ₁	D ₂	L	D ₁	D ₂
DGPAD ...-D22-JHP	145,1	147	94	145,1	147	94
DGPAD ...-D32-JHP	145,1	152	100	145,1	152	100
TAGPAD ...-D42-JHP	148	162	110	148	162	110
TAGPAD ...-D52-JHP	153	162	110	153	162	110
TAGPAD-XL ...-D52-JHP	153	175	118	153	175	118
TAGPAD-XL ...-D65-JHP	159,6	194	134	159,6	194	134
TAGPAD-XL ...-D82-JHP	169,6	194	134	169,6	194	134
TAGPAD-XL ...-D102-JHP	182,6	218	155	182,6	218	155

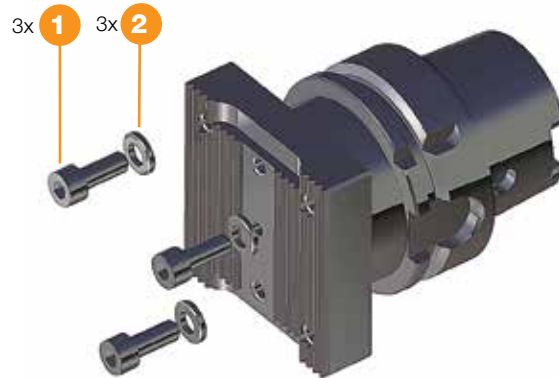

All trademarks and logos are the property of their respective companies

BI## MAHD#-#-XL-JHP
 Toolholders for Biglia Adaptation
 with Internal Coolant Supply for
 MODULAR-GRIP-XL Adapters

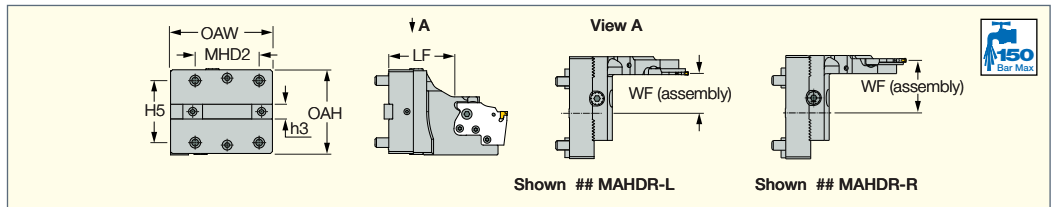

Designation	OAH	OAW	H ₅	MHD ₂	h ₃ ⁽¹⁾	LF	WF	Holder	Holder ₂
BI40 MAHDL-L-XL-JHP	70.0	83.00	50.00	50.0	12.0	62.60	43.60	BI40 V60-JHP	V60 MAHDL-L-XL-JHP
BI55 MAHDL-L-XL-JHP	85.0	103.50	63.00	65.0	15.0	67.10	53.10	BI55 V85-JHP	V85 MAHDL-L-XL-JHP
BI40 MAHDL-R-XL-JHP	70.0	83.00	50.00	50.0	12.0	62.60	29.50	BI40 V60-JHP	V60 MAHDL-R-XL-JHP
BI55 MAHDL-R-XL-JHP	85.0	103.50	63.00	65.0	15.0	67.10	40.50	BI55 V85-JHP	V85 MAHDL-R-XL-JHP
BI40 MAHDR-L-XL-JHP	70.0	83.00	50.00	50.0	12.0	62.60	29.50	BI40 V60-JHP	V60 MAHDR-L-XL-JHP
BI55 MAHDR-L-XL-JHP	85.0	103.50	63.00	65.0	15.0	67.10	40.50	BI55 V85-JHP	V85 MAHDR-L-XL-JHP
BI40 MAHDR-R-XL-JHP	70.0	83.00	50.00	50.0	12.0	62.60	43.60	BI40 V60-JHP	V60 MAHDR-R-XL-JHP
BI55 MAHDR-R-XL-JHP	85.0	103.50	63.00	65.0	15.0	67.10	53.10	BI55 V85-JHP	V85 MAHDR-R-XL-JHP

⁽¹⁾ Slot Nut

For tools, see pages: DGPAD-JHP (437) • TAGPAD-JHP (456) • TAGPAD-XL-JHP (456)
 • For user guide, see pages 503-517

Holder Spare Parts

Designation	(1) Screw	(2) Screw	(3) Shim
BI40 MAHD#-#-XL-JHP	SR M8X20DIN912 12.9	SR M6x16DIN912 12.9	ISO 7091 WASHER 6X12
BI55 MAHD#-#-XL-JHP	SR M10X25 DIN912-12.9	DIN7984-M8x20-8.8	ISO 7091 WASHER 8X16

Designation	(4) Slot Nuts	(5) Screw	(6) O-Ring
BI40 MAHD#-#-XL-JHP	NS 12x10x12	SR M5x12DIN912 12.9	OR 7x1.5xPERBUNAN
BI55 MAHD#-#-XL-JHP	NS 20x8.7x15	DIN912xM5x10	OR 7x1.5xPERBUNAN

For intermediate holder spare parts see page 530

Tool Dimensions with Adapter

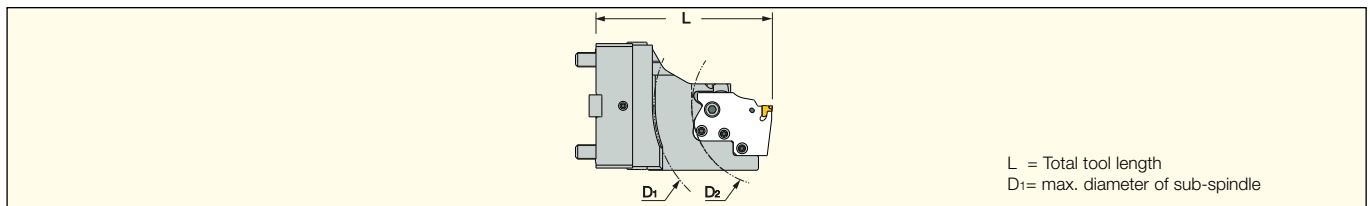

Adapter	BI40			BI55		
	L	D ₁	D ₂	L	D ₁	D ₂
DGPAD ...D22-JHP	108,1	147	94	112,6	147	94
DGPAD ...D32-JHP	108,1	147	94	112,6	147	94
TAGPAD ...D42-JHP	111	152	100	115,5	152	100
TAGPAD ...D52-JHP	116	162	110	120,5	162	110
TAGPAD-XL ...D52-JHP	116	162	110	120,5	162	110
TAGPAD-XL ...D65-JHP	122,6	175	118	127,1	175	118
TAGPAD-XL ...D82-JHP	132,6	194	134	137,1	194	134
TAGPAD-XL ...D102-JHP	145,6	218	155	150,1	218	155

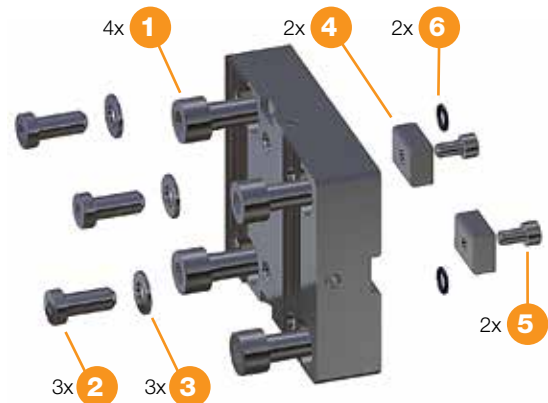

All trademarks and logos are the property of their respective companies



MI## MAHD#-#-XL-JHP
 Toolholders for Miyano Adaptation
 with Directed Internal Coolant for
 MODULAR-GRIP-XL Adapters

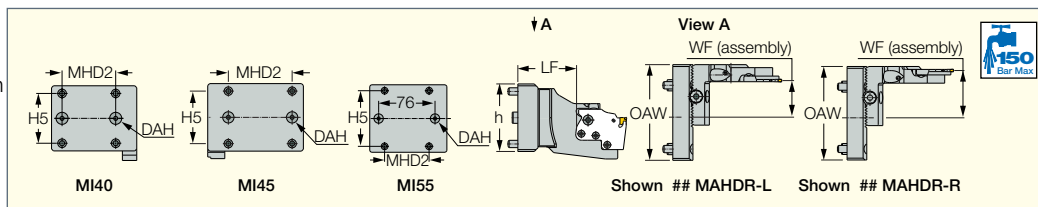

Designation	h	OAW	H ₅	MHD ₂	DAH	LF	WF	Holder	Holder ₂
MI40 MAHDL-L-XL-JHP	68.0	89.00	52.00	56.0	12.00	38.60	48.80	MI40 V60-JHP	V60 MAHDL-L-XL-JHP
MI45 MAHDL-L-XL-JHP	72.0	102.00	56.00	68.0	12.00	55.80	51.60	MI45 V60-JHP	V60 MAHDL-L-XL-JHP
MI55 MAHDL-L-XL-JHP	91.0	104.00	75.00	60.0	12.00	57.10	49.60	MI55 V60-JHP	V60 MAHDL-L-XL-JHP
MI40 MAHDL-R-XL-JHP	68.0	89.00	52.00	56.0	12.00	38.60	36.20	MI40 V60-JHP	V60 MAHDL-R-XL-JHP
MI45 MAHDL-R-XL-JHP	72.0	102.00	56.00	68.0	12.00	55.80	39.00	MI45 V60-JHP	V60 MAHDL-R-XL-JHP
MI55 MAHDL-R-XL-JHP	91.0	104.00	75.00	60.0	12.00	57.10	37.00	MI55 V60-JHP	V60 MAHDL-R-XL-JHP
MI40 MAHDR-L-XL-JHP	68.0	89.00	52.00	56.0	12.00	38.60	36.20	MI40 V60-JHP	V60 MAHDR-L-XL-JHP
MI45 MAHDR-L-XL-JHP	72.0	102.00	56.00	68.0	12.00	55.80	39.00	MI45 V60-JHP	V60 MAHDR-L-XL-JHP
MI55 MAHDR-L-XL-JHP	91.0	104.00	75.00	60.0	12.00	57.10	37.00	MI55 V60-JHP	V60 MAHDR-L-XL-JHP
MI40 MAHDR-R-XL-JHP	68.0	89.00	52.00	56.0	12.00	38.60	48.80	MI40 V60-JHP	V60 MAHDR-R-XL-JHP
MI45 MAHDR-R-XL-JHP	72.0	102.00	56.00	68.0	12.00	55.80	51.60	MI45 V60-JHP	V60 MAHDR-R-XL-JHP
MI55 MAHDR-R-XL-JHP	91.0	104.00	75.00	60.0	12.00	57.10	49.60	MI55 V60-JHP	V60 MAHDR-R-XL-JHP

For tools, see pages: DGPAD-JHP (437) • TAGPAD-JHP (456) • TAGPAD-XL-JHP (456)

• For user guide, see pages 503-517

Holder Spare Parts

Designation	(1) Screw	(2) Screw	(3) Shim	(4) Positioning pin
MI40 MAHD#-#-XL-JHP	SR M8x20DIN912 12.9	SR M6x16DIN912 12.9	ISO 7091 WASHER 8X16	PIN 12-5118172
MI45 MAHD#-#-XL-JHP	SR M8x20DIN912 12.9	SR M6x16DIN912 12.9	ISO 7091 WASHER 8X16	PIN 12-5118172
MI55 MAHD#-#-XL-JHP	SR M8x20DIN912 12.9	SR M6x16DIN912 12.9	ISO 7091 WASHER 8X16	PIN 12-5118172

For intermediate holder spare parts see page 530.

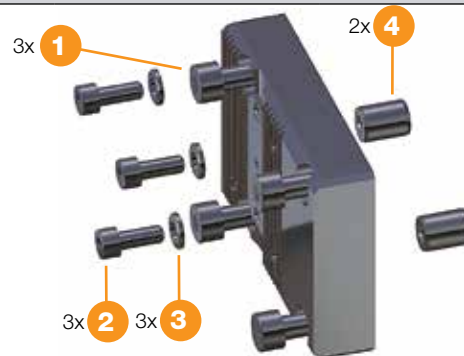

Tool Dimensions with Adapter

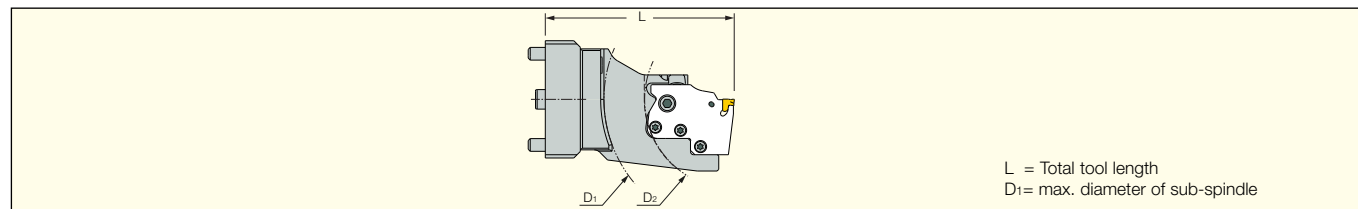

Adapter	MI40			MI45			MI55		
	L	D ₁	D ₂	L	D ₁	D ₂	L	D ₁	D ₂
DGPAD ...D22-JHP	84,1	99	46	101,3	147	94	108,1	147	94
DGPAD ...D32-JHP	84,1	99	46	101,3	147	94	108,1	147	94
TAGPAD ...D42-JHP	87	104	52	104,2	152	100	111	152	100
TAGPAD ...D52-JHP	92	114	62	109,2	162	110	116	162	110
TAGPAD-XL ...D52-JHP	92	114	62	109,2	162	110	116	162	110
TAGPAD-XL ...D65-JHP	98,6	127	70	115,8	175	118	122,6	175	118
TAGPAD-XL ...D82-JHP	108,6	146	86	125,8	194	134	132,6	194	134
TAGPAD-XL ...D102-JHP	121,6	170	107	145,6	218	155	145,6	218	155

NT## MAHD##-XL-JHP
 Toolholders for Nakamura-Tome Adaptation with Internal Coolant Supply for MODULAR-GRIP-XL Adapters

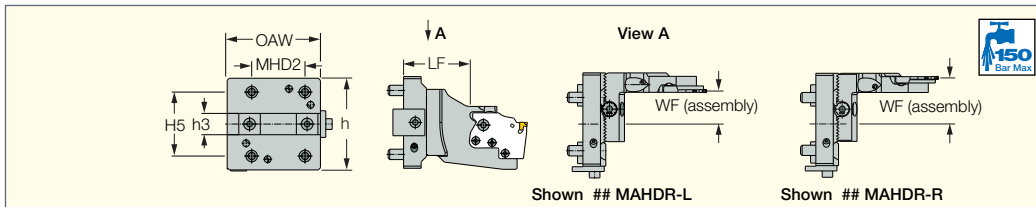

Designation	h	OAW	H ₅	MHD ₂	h ₃	LF	WF	Holder	Holder ₂
NT45 MAHDL-L-XL-JHP	80.0	76.50	55.00	40.0	20.0	62.60	40.60	NT45 V60-JHP	V60 MAHDL-L-XL-JHP
NT55 MAHDL-L-XL-JHP	86.0	87.50	60.00	50.0	20.0	62.60	43.60	NT55 V60-JHP	V60 MAHDL-L-XL-JHP
NT65 MAHDL-L-XL-JHP	100.0	99.50	71.00	69.0	20.0	62.60	42.60	NT65 V60-JHP	V60 MAHDL-L-XL-JHP
NT45 MAHDL-R-XL-JHP	80.0	76.50	55.00	40.0	20.0	62.60	29.00	NT45 V60-JHP	V60 MAHDL-R-XL-JHP
NT55 MAHDL-R-XL-JHP	86.0	87.50	60.00	50.0	20.0	62.60	31.00	NT55 V60-JHP	V60 MAHDL-R-XL-JHP
NT65 MAHDL-R-XL-JHP	100.0	99.50	71.00	69.0	20.0	62.60	33.00	NT65 V60-JHP	V60 MAHDL-R-XL-JHP
NT45 MAHDR-L-XL-JHP	80.0	76.50	55.00	40.0	20.0	62.60	29.00	NT45 V60-JHP	V60 MAHDR-L-XL-JHP
NT55 MAHDR-L-XL-JHP	86.0	87.50	60.00	50.0	20.0	62.60	3.00	NT55 V60-JHP	V60 MAHDR-L-XL-JHP
NT65 MAHDR-L-XL-JHP	100.0	99.50	71.00	69.0	20.0	62.60	33.00	NT65 V60-JHP	V60 MAHDR-L-XL-JHP
NT45 MAHDR-R-XL-JHP	80.0	76.50	55.00	40.0	20.0	62.60	40.60	NT45 V60-JHP	V60 MAHDR-R-XL-JHP
NT55 MAHDR-R-XL-JHP	86.0	87.50	60.00	50.0	20.0	62.60	15.60	NT55 V60-JHP	V60 MAHDR-R-XL-JHP
NT65 MAHDR-R-XL-JHP	100.0	99.50	71.00	69.0	20.0	62.60	42.60	NT65 V60-JHP	V60 MAHDR-R-XL-JHP

For tools, see pages: DGPAD-JHP (437) • TAGPAD-JHP (456) • TAGPAD-XL-JHP (456)

• For user guide, see pages 503-517

Holder Spare Parts

Designation	(1) Screw	(2) Screw	(3) Shim	(4) Slot nut	(5) Screw
NT45 MAHD##-XL-JHP	SR M8x20DIN912	SR M6x16DIN912 12.9	ISO 7091 WASHER 8X16	NS 20x10x20	SR M6x12DIN912 12.9
NT55 MAHD##-XL-JHP	SR M10x20DIN912 12.9	SR M6x16DIN912 12.9	ISO 7091 WASHER 8X16	NS 20x10x20	SR M6x12DIN912 12.9
NT65 MAHD##-XL-JHP	SR M10x20DIN912 12.9	SR M6x16DIN912 12.9	ISO 7091 WASHER 8X16	NS 20x10x20	SR M6x12DIN912 12.9

Designation	(6) Stopper	(7) Screw	(8) O-Ring
NT45 MAHD##-XL-JHP	KL-WT250-01 25x5x30	SR M6x12DIN912 12.9	O-RING 7.3x2.2NBR70
NT55 MAHD##-XL-JHP	KL-WT250-01 25x5x30	SR M6x12DIN912 12.9	O-RING 7.3x2.2NBR70
NT65 MAHD##-XL-JHP	KL-WT250-01 25x5x30	SR M6x12DIN912 12.9	O-RING 7.3x2.2NBR70

For intermediate holder spare parts see page 530.

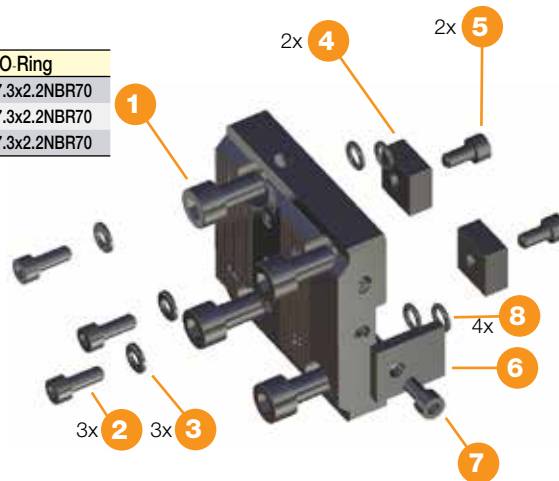

Tool Dimensions with Adapter

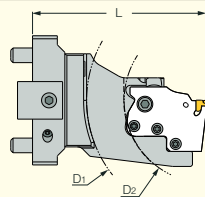

L = Total tool length
 D₁ = max. diameter of sub-spindle

Adapter	NT45			NT55			NT65		
	L	D ₁	D ₂	L	D ₁	D ₂	L	D ₁	D ₂
DGPAD ...-D22-JHP	108,1	147	94	108,1	147	94	108,1	147	94
DGPAD ...-D32-JHP	108,1	147	94	108,1	147	94	108,1	147	94
TAGPAD ...-D42-JHP	111	152	100	111	152	100	111	152	100
TAGPAD ...-D52-JHP	116	162	110	116	162	110	116	162	110
TAGPAD-XL ...-D52-JHP	116	162	110	116	162	110	116	162	110
TAGPAD-XL ...-D65-JHP	122,6	175	118	122,6	175	118	122,6	175	118
TAGPAD-XL ...-D82-JHP	132,6	194	134	132,6	194	134	132,6	194	134
TAGPAD-XL ...-D102-JHP	145,6	218	155	145,6	218	155	145,6	218	155

MODULAR-GRIP**OKUMA # MAHD#-#-XL-JHP**

Toolholders for Okuma Adaptation
with Internal Coolant Supply for
MODULAR-GRIP-XL Adapters

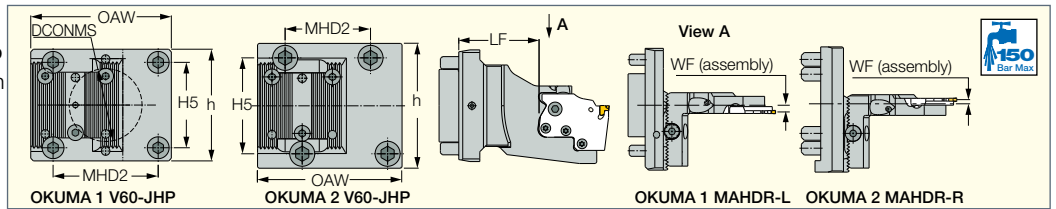

Designation	h	OAW	H ₅	MHD ₂	DCONMS	LF	WF	Holder	Holder ₂
OKUMA 1 MAHDL-L-XL-JHP	85.0	107.00	65.00	80.0	55.40	61.10	52.60	OKUMA 1 V60-JHP	V60 MAHDL-L-XL-JHP
OKUMA 2 MAHDL-L-XL-JHP	95.0	110.00 ⁽¹⁾	73.00	65.0	-	66.10	55.60	OKUMA 2 V60-JHP	V60 MAHDL-L-XL-JHP
OKUMA 1 MAHDL-R-XL-JHP	85.0	107.00	65.00	80.0	55.40	61.10	40.00	OKUMA 1 V60-JHP	V60 MAHDL-R-XL-JHP
OKUMA 2 MAHDL-R-XL-JHP	95.0	110.00 ⁽¹⁾	73.00	65.0	-	66.10	43.00	OKUMA 2 V60-JHP	V60 MAHDL-R-XL-JHP
OKUMA 1 MAHDR-L-XL-JHP	85.0	107.00	65.00	80.0	55.40	61.10	6.00	OKUMA 1 V60-JHP	V60 MAHDR-L-XL-JHP
OKUMA 2 MAHDR-L-XL-JHP	95.0	110.00 ⁽¹⁾	73.00	65.0	-	66.10	9.00	OKUMA 2 V60-JHP	V60 MAHDR-L-XL-JHP
OKUMA 1 MAHDR-R-XL-JHP	85.0	107.00	65.00	80.0	55.40	61.10	6.60	OKUMA 1 V60-JHP	V60 MAHDR-R-XL-JHP
OKUMA 2 MAHDR-R-XL-JHP	95.0	110.00 ⁽¹⁾	73.00	65.0	-	66.10	3.60	OKUMA 2 V60-JHP	V60 MAHDR-R-XL-JHP

⁽¹⁾ also available in 100.00 mm

For tools, see pages: DGPAD-JHP (437) • TAGPAD-JHP (456) • TAGPAD-XL-JHP (456)

• For user guide, see pages 503-517

MODULARGRIP

V## MAHD#-#-XL-##-JHP

Intermediate Holders for ISCAR Modular System Holders with Directed Internal Coolant for MODULAR-GRIP-XL Adapters

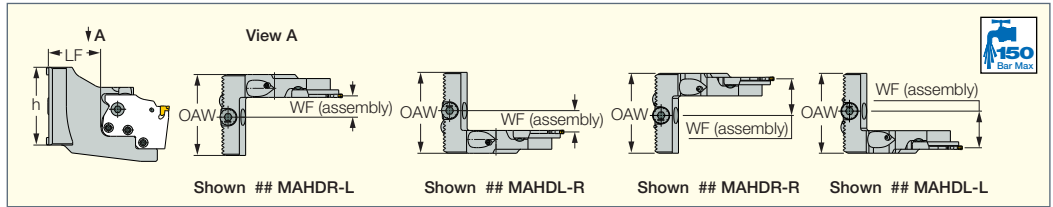

Designation	CSI	h	OAW	LF	WF
V60 MAHDL-L-XL-JHP	V60	75.0	64.50	42.65	29.60
V60 MAHDL-L-XL-LH-JHP	V60	75.0	64.50	69.15	29.60
V60 MAHDL-L-XL-SH-JHP	V60	75.0	64.50	18.65	32.80
V85 MAHDL-L-XL-JHP	V85	85.5	85.00	43.65	38.10
V85 MAHDL-L-XL-LH-JHP	V85	85.5	85.00	69.15	38.10
V85 MAHDL-L-XL-SH-JHP	V85	85.5	85.00	26.65	41.30
V60 MAHDL-R-XL-JHP	V60	75.0	64.50	42.65	25.50
V60 MAHDL-R-XL-LH-JHP	V60	75.0	64.50	69.15	25.50
V60 MAHDL-R-XL-SH-JHP	V60	75.0	64.50	18.65	25.50
V85 MAHDL-R-XL-JHP	V85	85.5	85.00	43.65	17.00
V85 MAHDL-R-XL-LH-JHP	V85	85.5	85.00	69.15	17.00
V85 MAHDL-R-XL-SH-JHP	V85	85.5	85.00	26.65	20.20
V60 MAHDR-L-XL-JHP	V60	75.0	64.50	42.65	25.50
V60 MAHDR-L-XL-LH-JHP	V60	75.0	64.50	69.15	25.50
V60 MAHDR-L-XL-SH-JHP	V60	75.0	64.50	18.65	25.50
V85 MAHDR-L-XL-JHP	V85	85.5	85.00	43.65	17.00
V85 MAHDR-L-XL-LH-JHP	V85	85.5	85.00	69.15	17.00
V85 MAHDR-L-XL-SH-JHP	V85	85.5	85.00	26.65	20.20
V60 MAHDR-R-XL-JHP	V60	75.0	64.50	42.65	29.60
V60 MAHDR-R-XL-LH-JHP	V60	75.0	64.50	69.15	29.60
V60 MAHDR-R-XL-SH-JHP	V60	75.0	64.50	18.65	32.80
V85 MAHDR-R-XL-JHP	V85	85.5	85.00	43.65	38.10
V85 MAHDR-R-XL-LH-JHP	V85	85.5	85.00	69.15	38.10
V85 MAHDR-R-XL-SH-JHP	V85	85.5	85.00	26.65	41.30

For tools, see pages: DGPAD-JHP (437) • TAGPAD-JHP (456) • TAGPAD-XL-JHP (456)

• For user guide, see pages 503-517

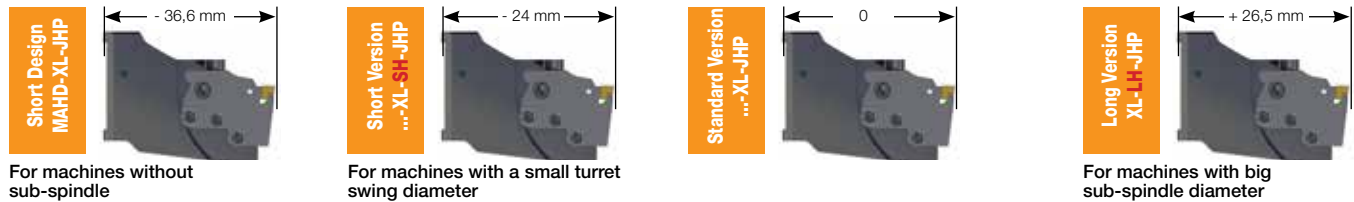

For machines without sub-spindle

For machines with a small turret swing diameter

For machines with big sub-spindle diameter

Intermediate Holder Spare Parts

Designation	(1) Clamping Screw	(2) Dummy	(3) Height Adjustment Screw	(4) O-Ring	(5) Screw	(6) Screw	(7) O-Ring
V## MAHD#-#-XL-##-JHP	SR M6x16DIN912 12.9	Dummy-MG-XL-5113377	SR 14-0194-56113373	O RING 8x3 NBR 70	SR M5-04451	SR M6x10DIN6912	OR 5x1N

Tool Dimensions with Adapter

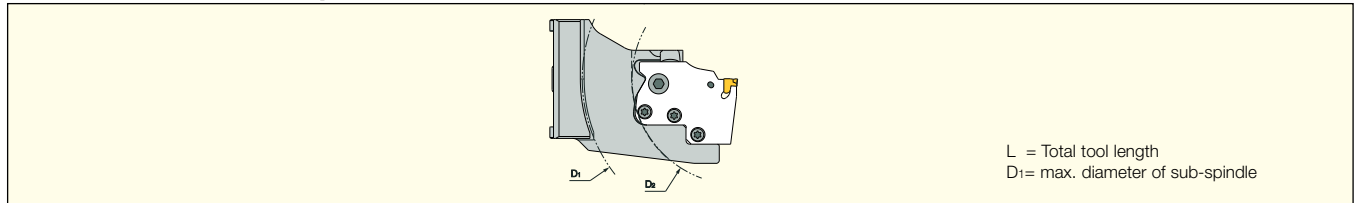

Adapter	V## MAHD#-#- XL-SH-JHP		V## MAHD#-#- XL-JHP		V## MAHD#-#- XL-LH-JHP	
	D1	D2	D1	D2	D1	D2
DGPAD ...-D22-JHP	99	46	147	94	200	147
DGPAD ...-D32-JHP	99	46	147	94	200	147
TAGPAD ...-D42-JHP	104	52	152	100	205	153
TAGPAD ...-D52-JHP	114	62	162	110	215	163
TAGPAD-XL ...-D52-JHP	114	62	162	110	215	163
TAGPAD-XL ...-D65-JHP	127	70	175	118	228	171
TAGPAD-XL ...-D82-JHP	146	86	194	134	247	187
TAGPAD-XL ...-D102-JHP	170	107	218	155	271	208

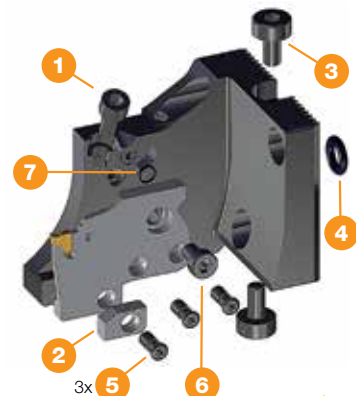

All trademarks and logos are the property of their respective companies

MODULAR-GRIP

V## MAHD-XL-JHP

Intermediate Holders for ISCAR Modular System Holders with Directed Internal Coolant for MODULAR-GRIP-XL Adapters

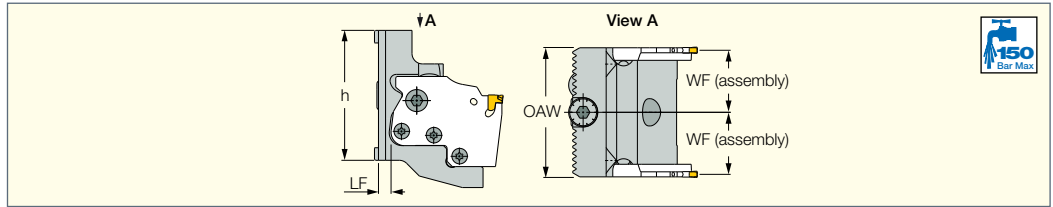

Designation	CSI	h	OAW	LF	WF
V60 MAHD-XL-JHP	V60	62.0	61.60	6.05	29.50
V85 MAHD-XL-JHP	V85	85.0	85.00	6.05	41.30

For tools, see pages: DGPAD-JHP (437) • TAGPAD-JHP (456) • TAGPAD-XL-JHP (456)

• For user guide, see pages 503-517

MODULAR-GRIP

V60 V60-L##

Spacer for ISCAR Modular System

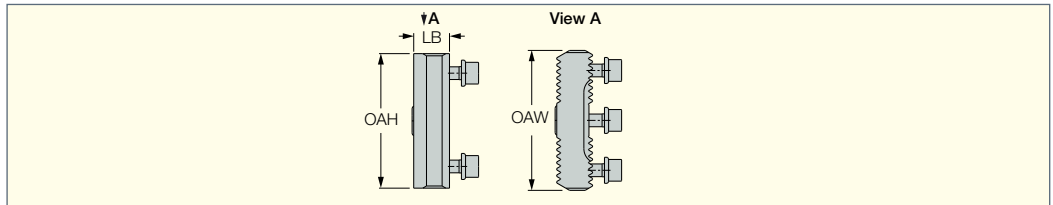

Designation	CSI	OAH	OAW	LB
V60 V60-L15	V60	62.0	64.50	15.00
V60 V60-L30	V60	62.0	64.50	30.00

• For user guide, see pages 503-517

TRAUB JETCUT

TR45 MAHDR-#-XL-JHP

Toolholders for Traub TNK45 / TNK 65 Machines with Directed Internal Coolant for MODULAR-GRIP-XL Adapters

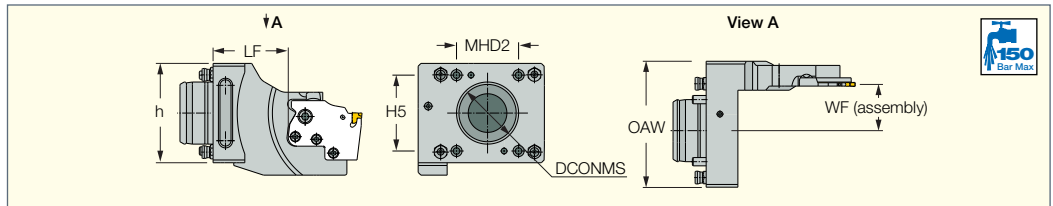

Designation	h	OAW	H ₅	MHD ₂	DCONMS	LF	WF
TR45 MAHDR-L-XL-JHP	72.0	91.50	55.00	45.0	45.00	54.40	33.50

For tools, see pages: DGPAD-JHP (437) • TAGPAD-JHP (456) • TAGPAD-XL-JHP (456)

• For user guide, see pages 503-517

Spare Parts

Designation	(1) Clamping Screw	(2) Dummy
TR45 MAHDR-L-XL-JHP	SR M6x16DIN912 12.9	Dummy-MG-XL-5113377

(3) Screw	(4) Screw	(5) O-Ring
SR M5-04451	SR M6x10DIN6912	OR 5x1N

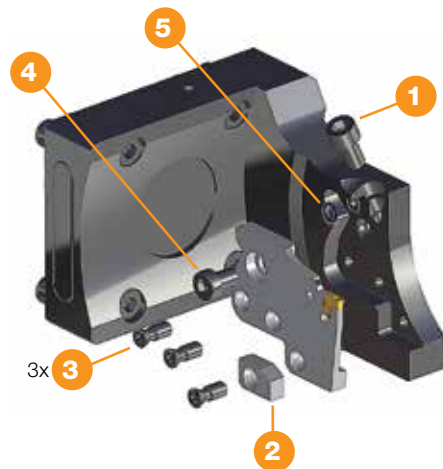

All trademarks and logos are the property of their respective companies

TR45TNL MAHDN-R-XL-JHP

Toolholders for Traub TNL16 to TNL18 / TNL32 Machines with Internal Coolant Supply for MODULAR-GRIP-XL Adapters

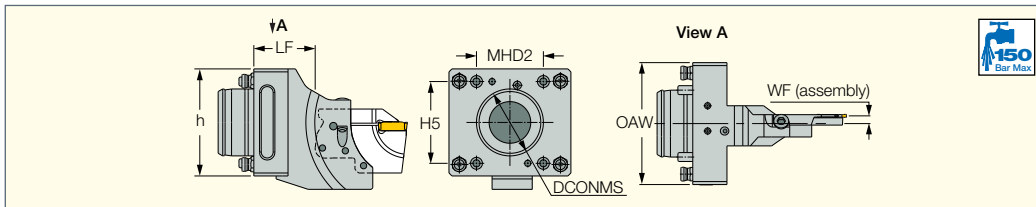

Designation	h	OAW	H5	MHD ₂	DCONMS	LF	WF
TR45TNL MAHDN-R-XL-JHP	72.0	82.00	55.00	45.0	45.00	41.30	6.00

For tools, see pages: DGPAD-XL-JHP (437) • TAGPAD-XL-JHP (456)

• For user guide, see pages 503-517

Spare Parts

Designation	(1) Clamping Screw	(2) Dummy
TR45TNL MAHDN-R-XL-JHP	SR M6x16DIN912 12.9	Dummy-MG-XL-5113377

(3) Screw	(4) Screw	(5) O-Ring
SR M5-04451	SR M6x10DIN6912	OR 5x1N

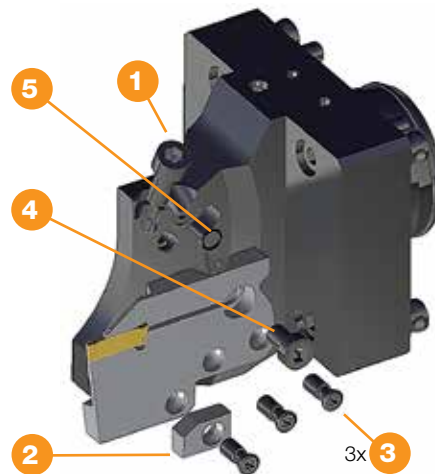

TR TNK36 MAHDL-R-XL-JHP

Toolholders for Traub TNK36 / TNL26 Machines with Internal Coolant Supply for MODULAR-GRIP-XL Adapters

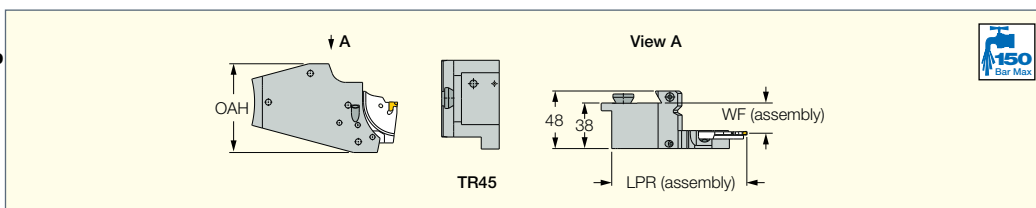

Designation	OAH	LPR	WF
TR TNK36 MAHDL-R-XL-JHP	74.0	91.50	24.50

For tools, see pages: DGPAD-XL-JHP (437) • TAGPAD-XL-JHP (456)

• For user guide, see pages 503-517

Spare Parts

Designation	(1) Clamping Screw	(2) Dummy	(3) Screw	(4) Screw	(5) O-Ring
TR TNK36 MAHDL-R-XL-JHP	SR M6x16DIN912 12.9	Dummy-MG-XL-5113377	SR M5-04451	SR M6x10DIN6912	OR 5x1N

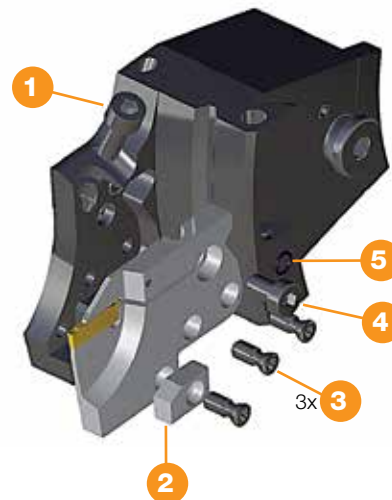

INDEX JETCUT

ABC MAHDR-#-XL-JHP
 Toolholders for Index ABC
 Speedline with Internal Coolant
 Supply for MODULAR-
 GRIP-XL Adapters

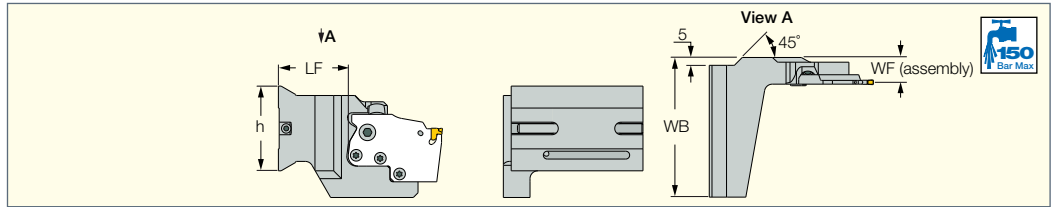

Designation	h	WB	LF	WF
ABC MAHDR-L-XL-JHP	56.0	91.50	44.55	17.00

For tools, see pages: DGPAD-JHP (437) • DGPAD-XL-JHP (437) • TAGPAD-JHP (456) • TAGPAD-XL-JHP (456)
 • For user guide, see pages 503-517

Spare Parts

Designation	(1) Clamping Screw	(2) Dummy	(3) Screw	(4) Screw	(5) Pin
ABC MAHDR-#-XL-JHP	SR M6x16DIN912 12.9	Dummy-MG-XL-5113377	SR M5-04451	SR M6x10DIN6912	SR M4x5DIN913 45H

Designation	(6) Stopper Screw	(7) Height Adjustment Screw	(8) O-Ring
ABC MAHDR-#-XL-JHP	DIN913-M6x80-45H	SR M5x8DIN913 45H	OR 5x1N

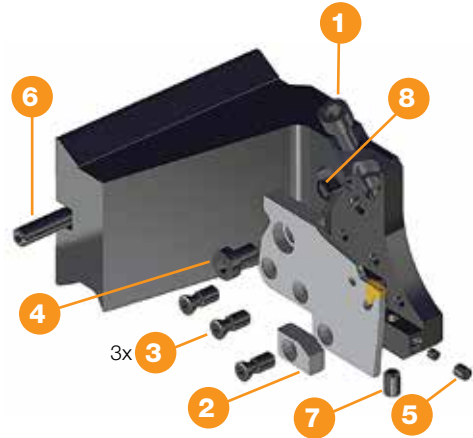

TOOL BLOCKS

V-ASH-MC
 Axially Oriented, Short, Right-
 Hand, Wedge Clamping Holders
 for Square Shank Tools

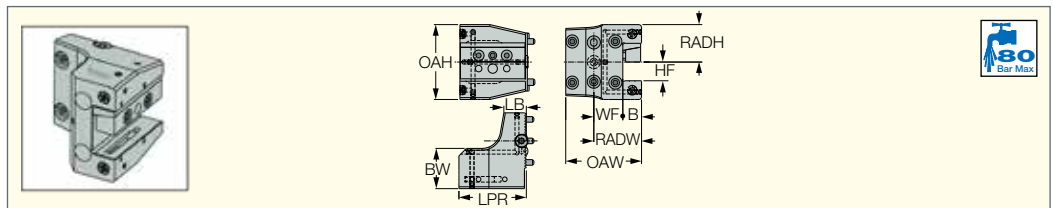

Designation	HF	WF	LPR	OAH	RADW	B	LB	RADH	BW	OAW
V60 ASH 20-MC	20.0	31.00	72.00	80.0	51.00	20.0	24.00	40.00	43.00	81.00
V60 ASH 25-MC	25.0	32.00	87.00	90.0	57.00	25.0	24.00	45.00	48.00	87.00
V85 ASHD 25-MC	25.0	43.00	87.00	100.0	68.00	25.0	26.00	50.00	55.00	110.50

FACE GROOVING AND TURNING

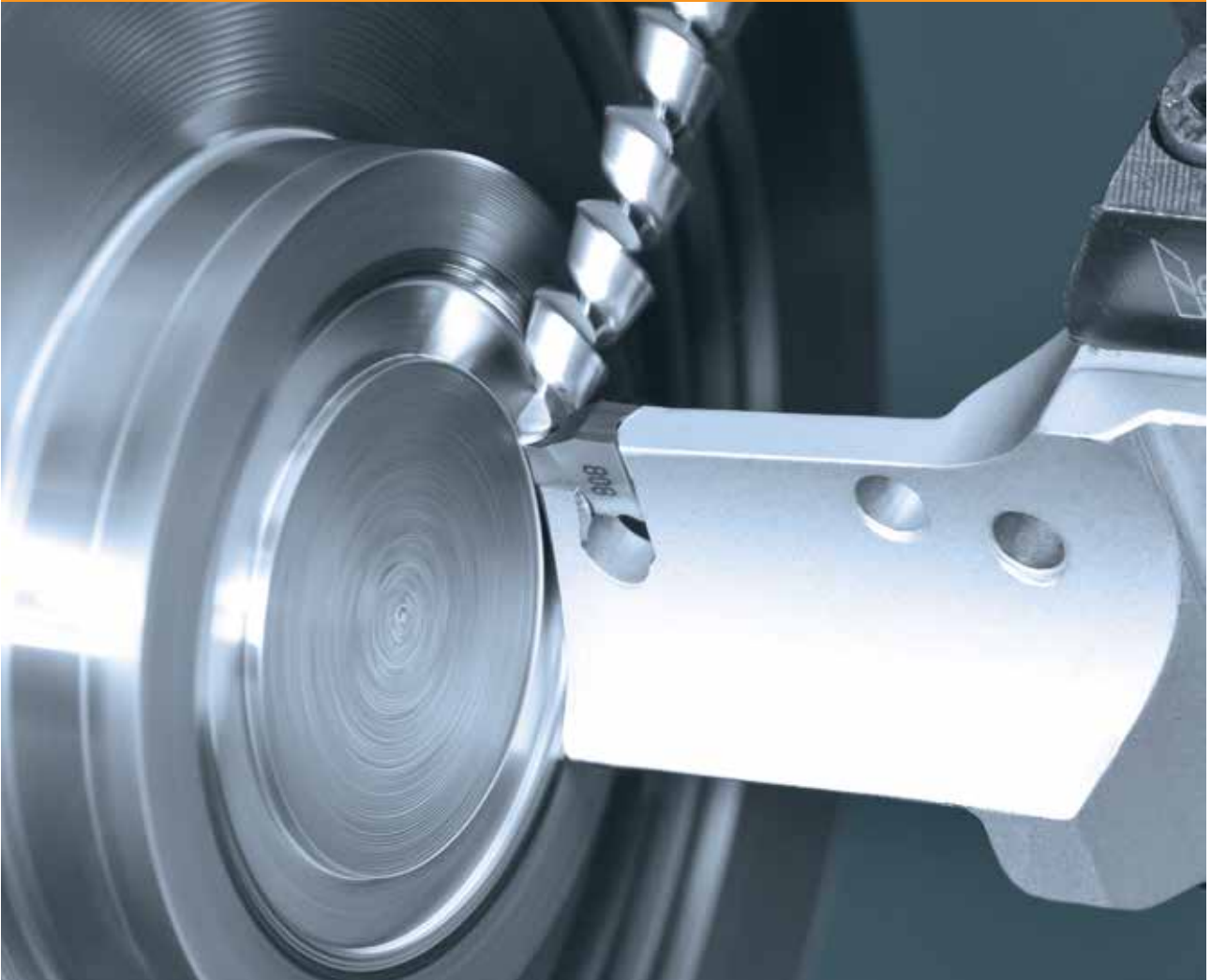

Selection Guide	534
Tools and Inserts	541
PICCO-CUT	541
CHAMGROOVE.....	543
MINCUT	544
HELI-FACE and HELI-GRIP	546
CUT-GRIP.....	561
TANG-GRIP	566
SELF-GRIP	568
PENTACUT.....	570
User Guide	572

A Variety of Inserts for Face Machining Applications

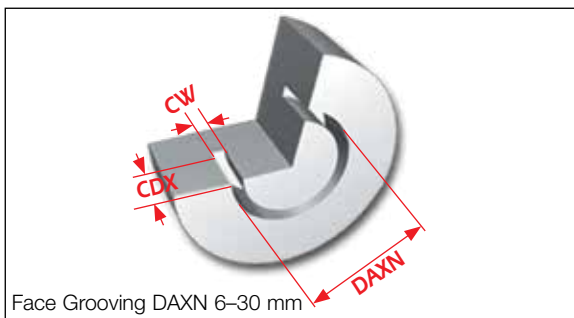

		DAXN	DAXX	CWN	CWX	CDX	Page
PICCO		6	–	1	3	30	541-543
MIFR		8	30	1.5	3.5	9	545
GFQR		12	19	1	2.5	3	543
HGPL		12	∞	3	6	∞	560
GRIP		12	∞	3	6	∞	559-560
DGN		21	∞	4	6	∞	438-440
TNF		30	700	3	6	∞	567
HFPN		27	130	2	2	14	557

Face Grooving DAXN 24–80 mm

		DAXN	DAXX	CWN	CWX	CDX	Page
HFPR/L		24	∞	3	6	∞	558
PENTA 34F		22	∞	2.39	4	5	570-571
GDMY/N		50	∞	8	8	25	272-273, 564-565
GIF 8		80	∞	8	8	25	563
GIFG 8		50	∞	8	8	25	563
GIMM 8CC		80	∞	7	8	∞	565
GDMM CC		50	∞	8	8	∞	565

Small Diameter Face Machining Systems

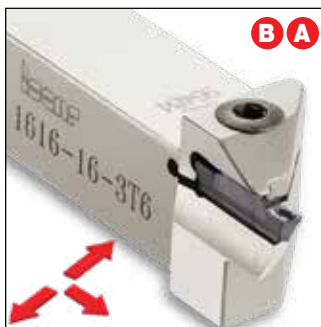

Tool: HGHR/L see page 547

Insert: GRIP... / HGPL...

CW = 3 mm

CDX = 6 mm

DAXN = 12 mm

Integral shank toolholder which uses double-ended 3 mm inserts. Used for face grooving and face turning of small parts for 12 mm minimum groove diameter.



Tool: HGAER/L... (adapter) see page 551

Tool: HFAER/L... (adapter) see pages 551-552

Insert: HFPR/L...

CW = 3-6 mm

CDX = 32 mm

DAXN = 12 mm

Exchangeable external adapters. Used with HELIFACE and GRIP inserts for deep face machining.

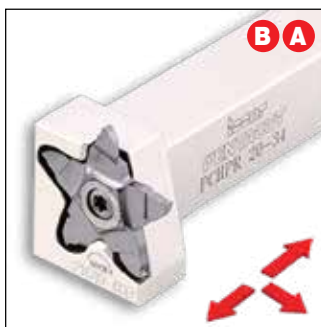

Tool: PCHPR/L see page 571

Insert: PENTA 34F...

CW = 2.39-4 mm

CDX = 5 mm

DAXN = 22 mm

Pentagonal insert for face grooving and recessing up to 5 mm depth of cut at a minimum of 22 mm diameter.



Tool: PICCO R010 see page 541

CW = 1-3 mm

CDX = 6 mm

DAXN = 6 mm

Small solid carbide bars for machining shallow grooves from 6 mm minimum diameter.

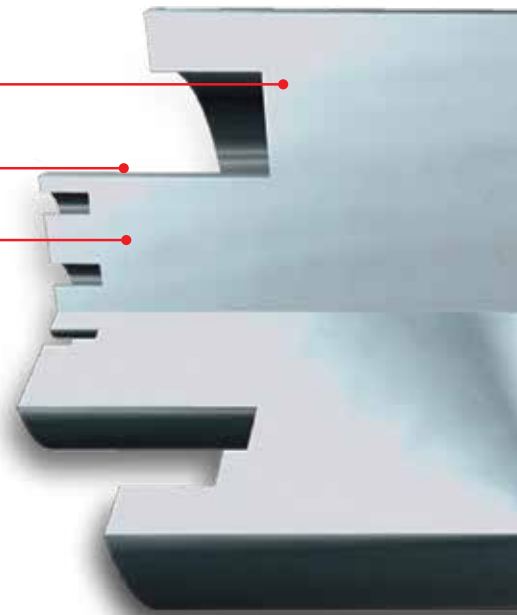



Tool: PICCO R015 see page 542

- CW = 2.5-3 mm**
- CDX = 30 mm**
- DAXN = 15 mm**

Small solid carbide bars for machining deep face grooves of up to 30 and 15 mm minimum diameter.



Tool: MIFHR ... see page 544

Insert: MIFR ...

- CW = 2-3 mm**
- CDX = 9 mm**
- DAXN = 10 mm**

MINCUT - A family of internal face grooving and face turning tools for machining small diameters ranging from 10-34 mm. Strong and stable tangential pocket with internal coolant.

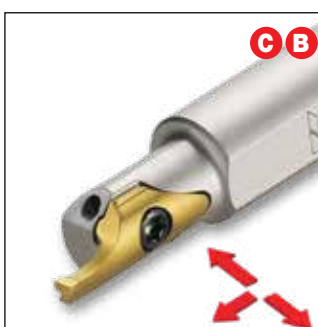

Tool: MIFHR ... see page 544

Insert: MIFR ...

- CW = 1.5-3 mm**
- CDX = 5.5 mm**
- DAXN = 8 mm**

MINCUT - A family of internal face grooving and face turning tools for machining small diameters ranging from 8-17 mm. Strong and stable tangential pocket with internal coolant.



Tool: MGCH 09C see page 543

Insert: GFQR...

- CW = 1-2.5 mm**
- CDX = 3 mm**
- DAXN = 12 mm**

A screw-clamped insert on an internal coolant solid carbide bar. Used for machining shallow grooves from 12 mm minimum diameter.



Main Applications

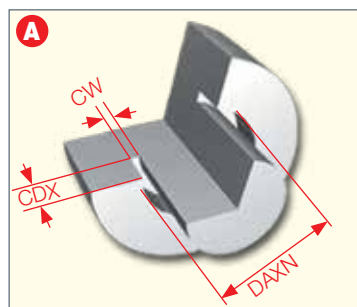

Grooving Next to a Shaft

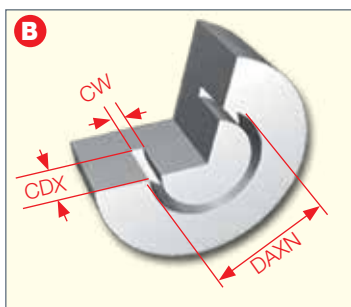

External Grooving

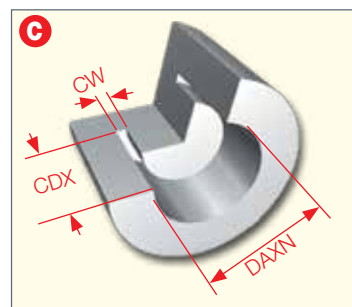

Internal Grooving

**Medium Diameter
Face Machining Systems**

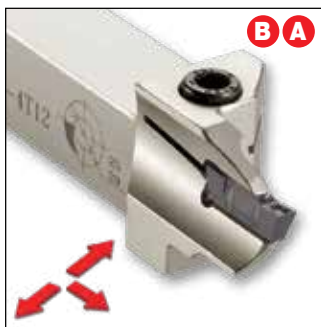

Tool: HFHR/L... see pages 547-549

Insert: HFPR/L...

CW = 3-6 mm

CDX = 32 mm

DAXN = 25 mm

Integral shank toolholders carrying HELIFACE and GRIP inserts. For deep face grooving and side face turning.

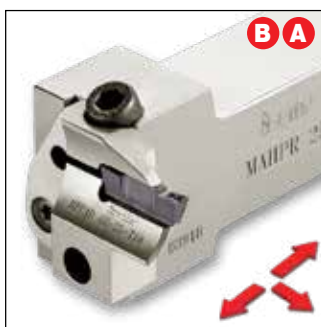

Tool: HFPAD... (adapter) see pages 549-550

Insert: HFPR/L...

CW = 3-6 mm

CDX = 22 mm

DAXN = 25 mm

Slanted, screw-clamped adapter carrying HELIFACE and GRIP inserts. A part of the MODULAR-GRIP system. Very rigid, for tough face operations.

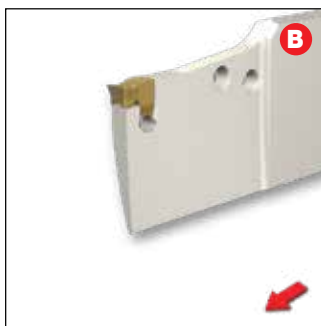

Tool: TNFFH see page 566

Insert: TNF 3-6C...

CW = 3-6 mm

CDX = 32 mm

DAXN = 30 mm

Adapter and blade toolholders carrying TNF 3-6C inserts. For deep face grooving.

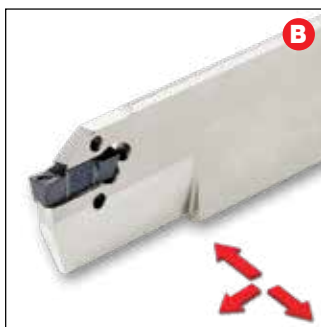

Tool: HFFR/L... see page 550

Insert: HFPR/L...

CW = 4-6 mm

CDX = 38 mm

DAXN = 48 mm

Economical, double-ended blades carrying HELIFACE and GRIP inserts. Recommended for deep face grooving and face turning to a maximum depth of 38 mm.

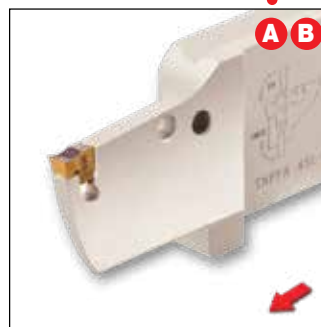

Tool: TNFFA see page 566

Insert: TNF 3-6C...

CW = 3-6 mm

CDX = 32 mm

DAXN = 30 mm

Reinforced blades carrying TNF 3-6C inserts. Recommended for face grooving only. Can machine along a shaft. Excellent chip evacuation.

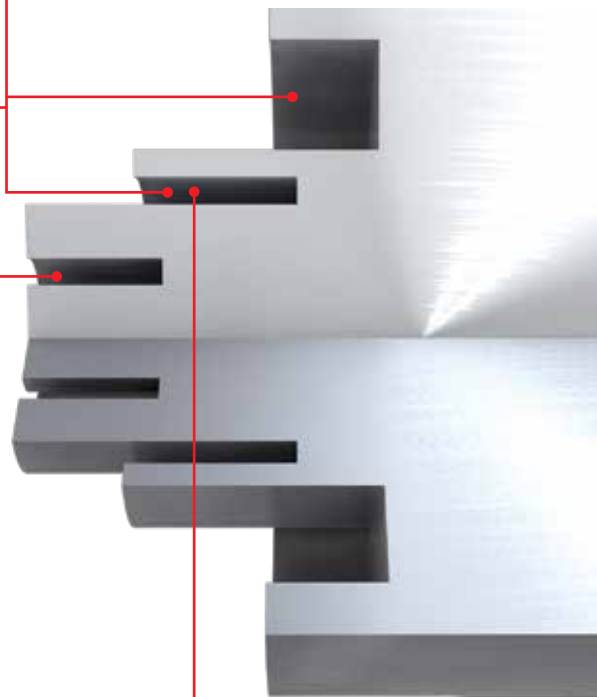

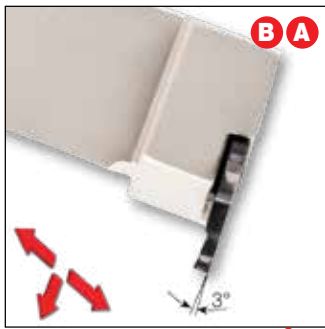

Tool: PCHPRS/LS see page 571
Insert: PENTA 34F-RS/LS...

- CW = 2.39-4 mm**
- CDX = 5 mm**
- DAXN = 22 mm**

Pentagonal insert for face grooving and recessing next to shoulders up to 5 mm depth of cut at a minimum of 22 mm diameter.

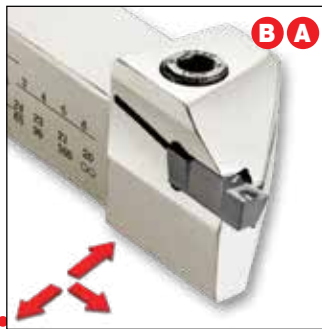

Tool: HFHR/L...-M see page 552
Insert: HFPR/L...

- CW = 3-6 mm**
- CDX = 5 mm**
- DAXN = 20 mm**

Integral toolholders carrying HELIFACE and GRIP inserts. For machining up to 5 mm depth of cut. 3-6 mm wide inserts can be mounted in the same pocket.

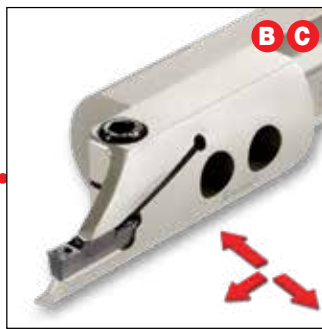

Tool: HFAIR/L...& HGAIR/L (adapter) see pages 554-555
Insert: HFPR/L...

- CW = 3-6 mm**
- CDX = 12 mm**
- DAXN = 32 mm**

Exchangeable, internal coolant adapters carrying HELIFACE and GRIP inserts. Recommended for deep internal face machining.

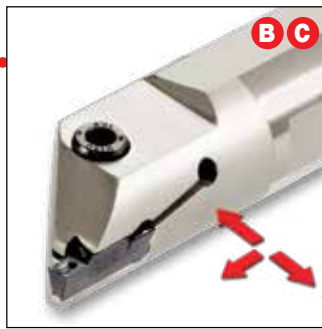

Tool: HFIR/L...-MC see page 556
Insert: HFPR/L...

- CW = 3-6 mm**
- CDX = 5 mm**
- DAXN = 20 mm**

Boring bars for shallow face machining of up to 5 mm depth carrying HELIFACE and GRIP inserts. Internal coolant. 3-6 mm width inserts can be mounted on the same pocket.

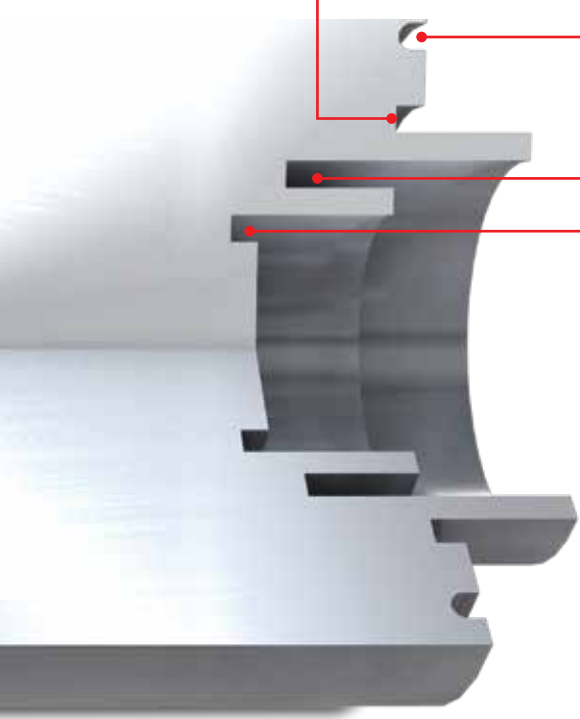

Main Applications

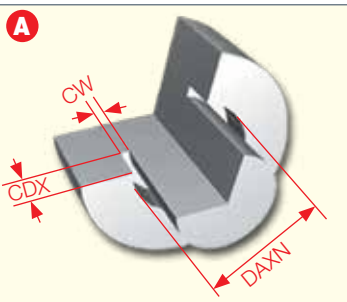

Grooving Next to a Shaft

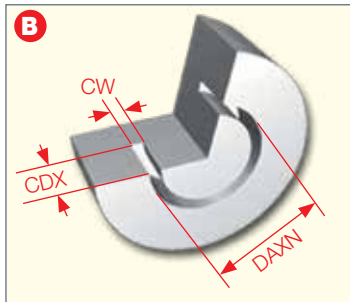

External Grooving

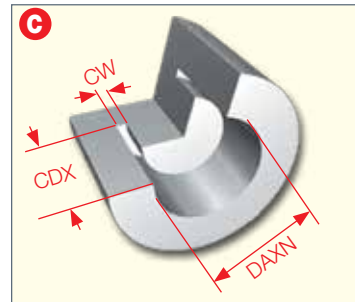

Internal Grooving

**Large Diameter
Face Machining Systems**

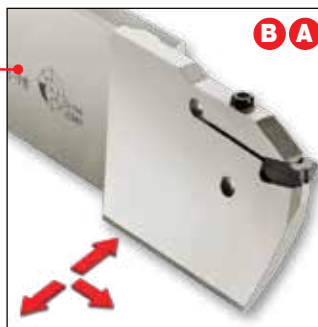
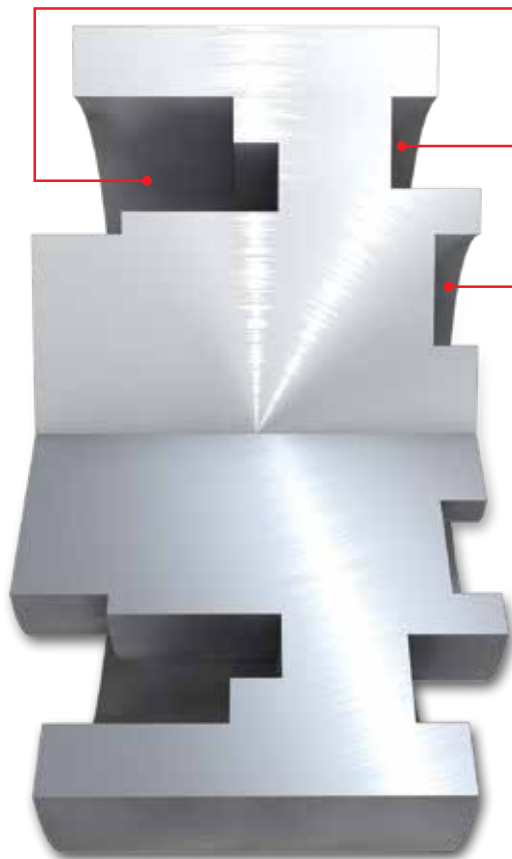

Tool: CGFG 51-..R/L-P8
see page 563
Insert: GIMY 8...
CW = 8 mm
CDX = 120 mm
DAXN = 180 mm

Blades carrying 8 mm single-ended CUT-GRIP inserts. Can machine up to 120 mm depth next to a shaft. Used for large diameters.

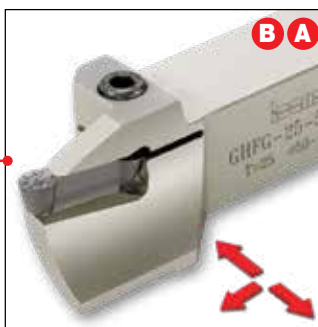

Tool: GHFG ..R/L-8 see page 561
Insert: GDMY 8..
CW = 8 mm
CDX = 25 mm
DAXN = 50 mm

Integral toolholders carrying 8 mm CUT-GRIP inserts. For heavy machining of medium and large parts. Can machine next to a shaft of up to 25 mm depth.

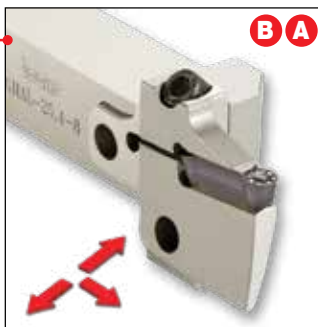

Tool: GAFG ..R/L-8 (adapter)
see page 562
Insert: GDMM 8CC
CW = 8 mm
CDX = 25 mm
DAXN = 80 mm

Exchangeable adapters carrying 8 mm CUT-GRIP inserts. Can machine up to 25 mm depth next to a shaft. For heavy machining of medium and large parts.

Main Applications

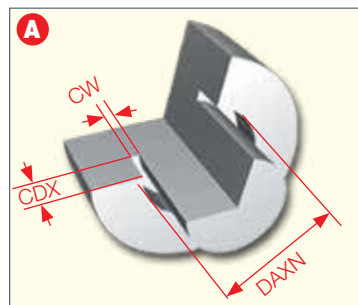

Grooving Next to a Shaft

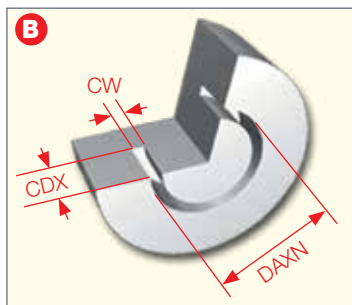

External Grooving

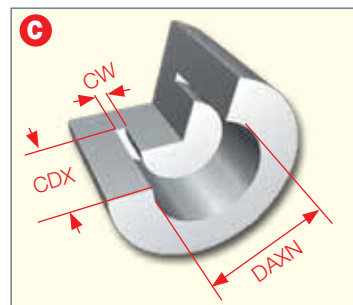

Internal Grooving

PICCO-010/610 (face grooving)

Inserts for Face Grooving

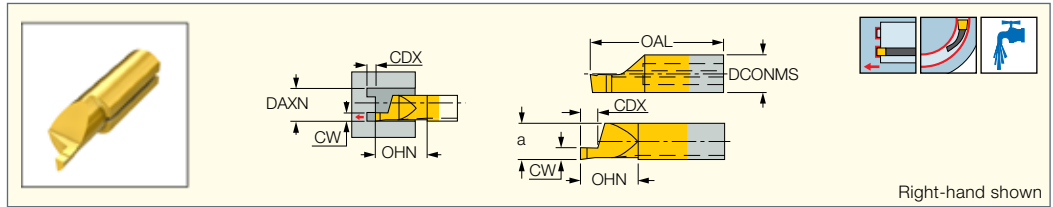

Designation	Dimensions							IC228	Recommended Machining Data
	DAXN ⁽¹⁾	CW	CDX	DCONMS	a	OHN ⁽²⁾	OAL		
PICCO R 010.1006-10	6.0	1.00	1.50	6.00	5.20	11.0	26.00	●	0.01-0.04
PICCO R 010.1506-10	6.0	1.50	2.00	6.00	5.20	11.0	26.00	●	0.01-0.04
PICCO R 010.1008-10	8.0	1.00	1.50	7.00	5.90	11.0	26.00	●	0.01-0.04
PICCO R 010.1008-20	8.0	1.00	1.50	7.00	5.90	21.0	35.00	●	0.01-0.04
PICCO R 010.1008-30	8.0	1.00	1.50	7.00	5.90	30.0	45.00	●	0.01-0.04
PICCO R 610.1008-10	8.0	1.00	1.50	6.00	5.20	11.0	26.00	●	0.01-0.04
PICCO R 610.1008-20	8.0	1.00	1.50	6.00	5.20	20.0	35.00	●	0.01-0.04
PICCO R/L 010.1508-20	8.0	1.50	2.50	7.00	5.90	21.0	35.00	●	0.01-0.04
PICCO R/L 010.1508-30	8.0	1.50	2.50	7.00	5.90	30.0	45.00	●	0.01-0.04
PICCO R 010.1508-10	8.0	1.50	2.50	7.00	5.90	11.0	26.00	●	0.01-0.04
PICCO R 610.1508-10	8.0	1.50	2.50	6.00	5.20	11.0	26.00	●	0.01-0.04
PICCO R 610.1508-20	8.0	1.50	2.50	6.00	5.20	20.0	35.00	●	0.01-0.04
PICCO R/L 010.2008-30	8.0	2.00	3.00	7.00	5.90	30.0	45.00	●	0.02-0.05
PICCO R 010.2008-10	8.0	2.00	3.00	7.00	5.90	11.0	26.00	●	0.02-0.05
PICCO R 010.2008-20	8.0	2.00	3.00	7.00	5.90	21.0	35.00	●	0.02-0.05
PICCO R 610.2008-10	8.0	2.00	3.00	6.00	5.20	11.0	26.00	●	0.02-0.05
PICCO R 610.2008-20	8.0	2.00	3.00	6.00	5.20	20.0	35.00	●	0.02-0.05
PICCO R 010.2508-10	8.0	2.50	3.50	7.00	5.90	11.0	26.00	●	0.02-0.05
PICCO R 010.2508-20	8.0	2.50	3.50	7.00	5.90	21.0	35.00	●	0.02-0.05
PICCO R 010.2508-30	8.0	2.50	3.50	7.00	5.90	30.0	45.00	●	0.02-0.05
PICCO R 610.2508-10	8.0	2.50	3.50	6.00	5.20	11.0	26.00	●	0.02-0.05
PICCO R 610.2508-20	8.0	2.50	3.50	6.00	5.20	20.0	35.00	●	0.02-0.05
PICCO R 010.3008-10	8.0	3.00	3.50	7.00	5.90	11.0	26.00	●	0.02-0.06
PICCO R 010.3008-20	8.0	3.00	3.50	7.00	5.90	21.0	35.00	●	0.02-0.06
PICCO R 010.3008-30	8.0	3.00	3.50	7.00	5.90	30.0	45.00	●	0.02-0.06
PICCO R 610.3008-10	8.0	3.00	3.50	6.00	5.20	11.0	26.00	●	0.02-0.06
PICCO R 610.3008-20	8.0	3.00	3.50	6.00	5.20	20.0	35.00	●	0.02-0.06

• Only right-hand inserts are available as standard • All inserts are with sharp corners • For detailed cutting data, see pages 574-575

⁽¹⁾ Minimum axial grooving diameter

⁽²⁾ Minimum overhang

PICCO-010 (round face groove)

Inserts for Round Profile Face Grooving

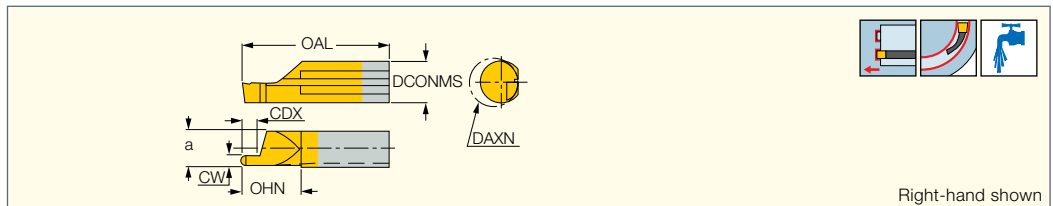

Designation	Dimensions								IC1008	Recommended Machining Data
	DAXN ⁽¹⁾	CW	RE	CDX	DCONMS	a	OHN ⁽²⁾	OAL		
PICCO R 010.1005-10	8.0	1.00	0.50	2.00	7.00	5.90	11.0	26.00	●	0.01-0.04
PICCO R 010.1005-20	8.0	1.00	0.50	2.00	7.00	5.90	20.0	35.00	●	0.01-0.04
PICCO R 010.1608-10	8.0	1.60	0.80	3.00	7.00	5.90	11.0	26.00	●	0.01-0.05
PICCO R 010.1608-20	8.0	1.60	0.80	3.00	7.00	5.90	20.0	35.00	●	0.01-0.05
PICCO R 010.2010-10	8.0	2.00	1.00	4.00	7.00	5.90	11.0	26.00	●	0.02-0.05
PICCO R 010.2010-20	8.0	2.00	1.00	4.00	7.00	5.90	20.0	35.00	●	0.02-0.05
PICCO R 010.2512-10	8.0	2.50	1.25	5.00	7.00	5.90	11.0	26.00	●	0.02-0.05
PICCO R 010.2512-20	8.0	2.50	1.25	5.00	7.00	5.90	20.0	35.00	●	0.02-0.05
PICCO R 010.3015-10	8.0	3.00	1.50	6.00	7.00	5.90	11.0	26.00	●	0.02-0.05
PICCO R 010.3015-20	8.0	3.00	1.50	6.00	7.00	5.90	20.0	35.00	●	0.02-0.05

• Only right-hand inserts are available as standard, left-hand inserts on request • For detailed cutting data, see pages 574-575

⁽¹⁾ Minimum axial grooving diameter

⁽²⁾ Minimum overhang

PICCO CUT

PICCO-620
(groove along shaft)
Inserts for Grooving Along
a Shaft DAXN 6 mm

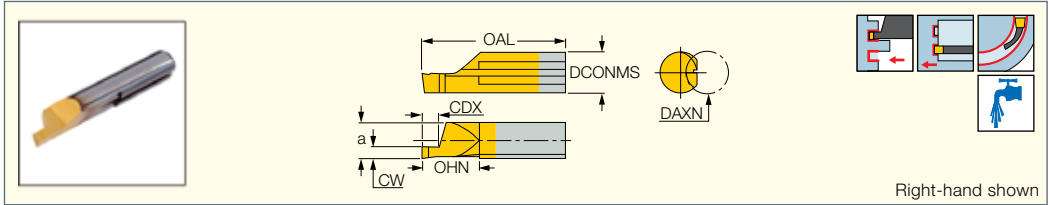

Right-hand shown

Designation	Dimensions							IC1008	Recommended Machining Data
	DAXN ⁽¹⁾	CW	CDX	DCONMS	a	OHN ⁽²⁾	OAL		f face-groove (mm/rev)
PICCO R 620.1006-20	6.0	1.00	2.00	6.00	5.20	20.0	35.00	●	0.01-0.04
PICCO R 620.1506-20	6.0	1.50	3.00	6.00	5.20	20.0	35.00	●	0.01-0.05
PICCO R 620.2006-20	6.0	2.00	4.00	6.00	5.20	20.0	35.00	●	0.02-0.06
PICCO R 620.2506-20	6.0	2.50	5.00	6.00	5.20	20.0	35.00	●	0.02-0.06
PICCO R 620.3006-20	6.0	3.00	6.00	6.00	5.20	20.0	35.00	●	0.02-0.06

• Only right-hand inserts are available as standard, left-hand inserts on request • All carbide inserts are with sharp corners • For detailed cutting data, see pages 574-575
⁽¹⁾ Minimum axial grooving diameter
⁽²⁾ Minimum overhang

PICCO CUT

PICCO-016/020
(face grooving)
Inserts with Coolant Holes
for Deep Face Grooving

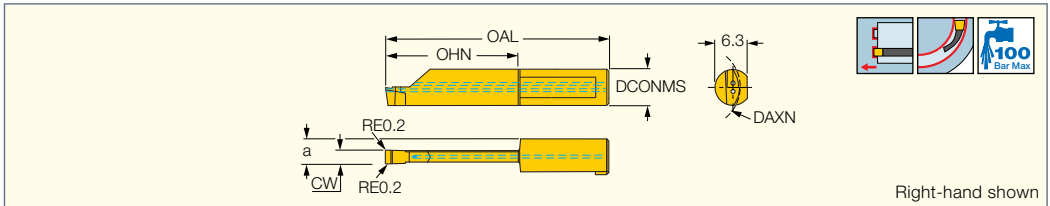

Right-hand shown

Designation	Dimensions							IC1008	Recommended Machining Data
	DAXN ⁽¹⁾	CW	OHN ⁽²⁾	DCONMS	a	OAL	f face-groove (mm/rev)		
PICCO R 016.0300-10	16.0	3.00	10.00	8.00	5.50	30.00	●	0.01-0.05	
PICCO R 016.0300-20	16.0	3.00	20.00	8.00	5.50	40.00	●	0.01-0.05	
PICCO R 016.0400-10	16.0	4.00	10.00	8.00	6.00	30.00	●	0.01-0.05	
PICCO R 016.0400-20	16.0	4.00	20.00	8.00	6.00	40.00	●	0.01-0.05	
PICCO R 020.0300-25	20.0	3.00	25.00	8.00	5.50	45.00	●	0.01-0.05	
PICCO R 020.0300-30	20.0	3.00	30.00	8.00	5.50	50.00	●	0.01-0.04	
PICCO R 020.0300-35	20.0	3.00	35.00	8.00	5.50	55.00	●	0.01-0.04	
PICCO R 020.0300-40	20.0	3.00	40.00	8.00	5.50	60.00	●	0.01-0.04	
PICCO R 020.0400-25	20.0	4.00	25.00	8.00	6.00	45.00	●	0.01-0.06	
PICCO R 020.0400-30	20.0	4.00	30.00	8.00	6.00	50.00	●	0.01-0.06	
PICCO R 020.0400-35	20.0	4.00	35.00	8.00	6.00	55.00	●	0.01-0.05	
PICCO R 020.0400-40	20.0	4.00	40.00	8.00	6.00	60.00	●	0.01-0.05	
PICCO R 020.0500-20	20.0	5.00	20.00	8.00	6.50	40.00	●	0.02-0.06	
PICCO R 020.0500-25	20.0	5.00	25.00	8.00	6.50	45.00	●	0.02-0.06	
PICCO R 020.0500-30	20.0	5.00	30.00	8.00	6.50	50.00	●	0.02-0.06	
PICCO R 020.0500-35	20.0	5.00	35.00	8.00	6.50	55.00	●	0.02-0.05	
PICCO R 020.0500-40	20.0	5.00	40.00	8.00	6.50	60.00	●	0.02-0.05	

• All inserts have two coolant holes which may be used with coolant pressure up to 100 bars • For detailed cutting data, see pages 574-575
⁽¹⁾ Minimum axial grooving diameter
⁽²⁾ Minimum overhang

PICCO CUT

PICCO-015
(face grooving)
Inserts for Deep Face Grooving

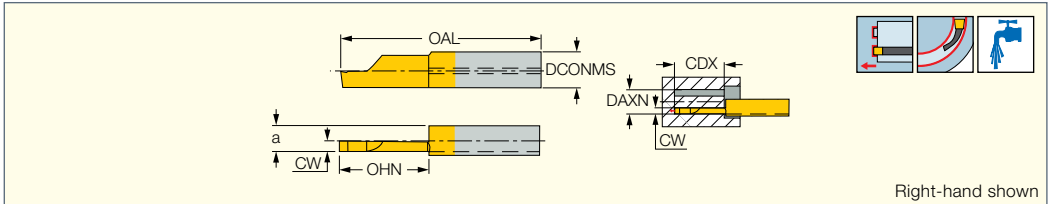

Right-hand shown

Designation	Dimensions							IC228	Recommended Machining Data
	DAXN ⁽¹⁾	CW	OHN ⁽²⁾	DCONMS	a	OAL	CDX		f face-groove (mm/rev)
PICCO R 015.2515-20	15.0	2.50	20.00	7.00	5.90	35.00	20.00	●	0.01-0.04
PICCO R/L 015.3015-20	15.0	3.00	20.00	7.00	5.90	35.00	20.00	●	0.02-0.05
PICCO R 015.3015-30	15.0	3.00	30.00	7.00	5.90	45.00	30.00	●	0.01-0.04

• Only right-hand inserts are available as standard, left-hand inserts on request • All inserts are with sharp corners • For detailed cutting data, see pages 574-575
⁽¹⁾ Minimum axial grooving diameter
⁽²⁾ Minimum overhang

PICCO CUT

KIT PICCO Face

Contains One Toolholder and a Set of Solid Carbide Miniature Face Turning and Grooving Boring Bars

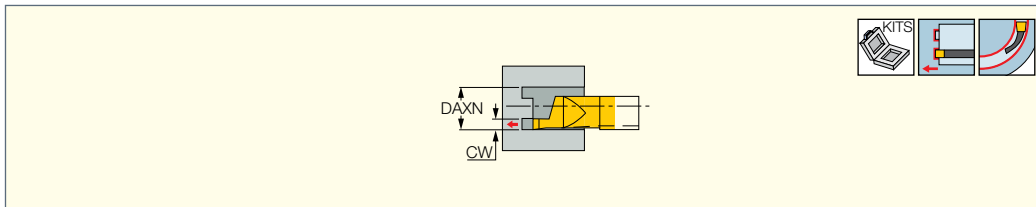

Designation	DAXN ⁽¹⁾	CWN ⁽²⁾	CWX ⁽³⁾
KIT PICCO SET-4R	8.0	1.00	3.00

- ⁽¹⁾ Minimum axial grooving diameter
- ⁽²⁾ Minimum cutting width
- ⁽³⁾ Maximum cutting width

PICCO

Face Grooving PICCO Mini-Bar Tool Set - 4R

Designation	Mini Bore Dia.	OHN	CDX	CW	Pcs.	Designation
PICCO 16.D6					1x	Holder
PICCO R/L 010.1008-10	8.0	11	1.5	1.0	1x	Mini Carbide Bar
PICCO R/L 010.1508-10	8.0	11	2.5	1.5	1x	Mini Carbide Bar
PICCO R/L 010.2008-10	8.0	11	3.0	2.0	1x	Mini Carbide Bar
PICCO R/L 010.2508-20	8.0	21	3.5	2.5	1x	Mini Carbide Bar
PICCO R/L 010.3008-20	8.0	21	3.5	3.0	1x	Mini Carbide Bar

Available grade: IC228

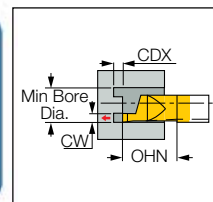



CHAMGROOVE

MGCH-C (face)

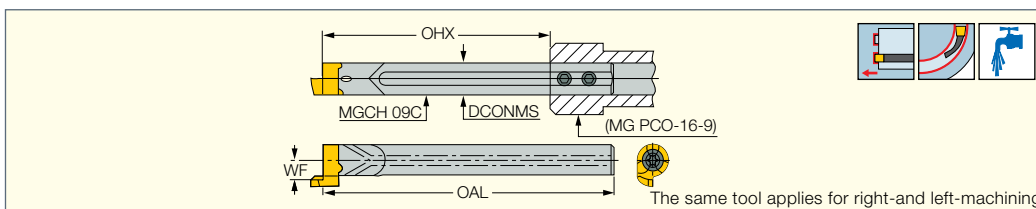
Face Machining Tools Carrying GFQR Inserts for DAXN 12 - DAXX 19 mm Penetration Range



Designation	DCONMS	OAL	OHX ⁽¹⁾	WF		
MGCH 09C	9.00	83.50	65.0	5.50	SR 76-2145	T-15/5

- ⁽¹⁾ Maximum overhang

For inserts, see pages: GFQR (543)

For holders, see pages: PICCO/MG PCO (holder) (360)

MG PCO

Holder Bar for Adjustable Shank

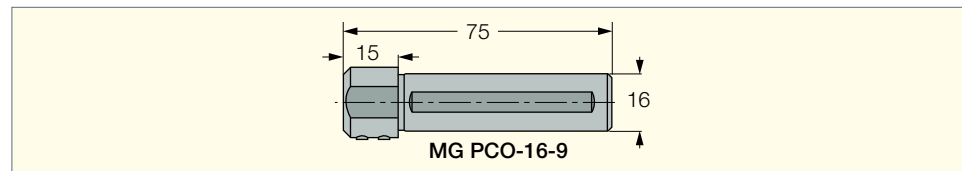

CHAMGROOVE

GFQR

Face Grooving Inserts

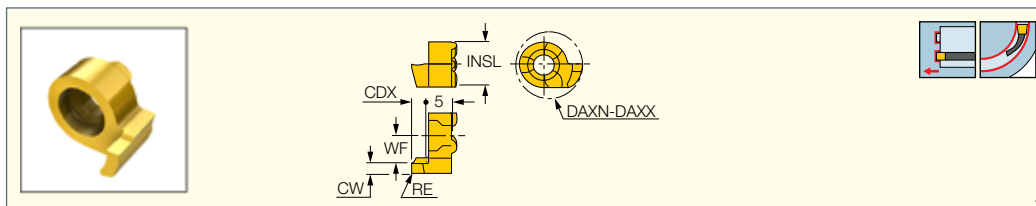

Designation	Dimensions							IC528	Recommended Machining Data f face-groove (mm/rev)
	CW	RE	CWTOL ⁽¹⁾	RETOL ⁽²⁾	CDX	DAXN ⁽³⁾	DAXX ⁽⁴⁾		
GFQR 12-1.00-0.05	1.00	0.05	0.02	0.030	1.50	12.0	16.0	●	0.01-0.04
GFQR 12-1.50-0.20	1.50	0.20	0.02	0.030	2.50	12.0	17.0	●	0.01-0.04
GFQR 12-2.00-0.20	2.00	0.20	0.02	0.030	3.00	12.4	18.0	●	0.02-0.05
GFQR 12-2.50-0.20	2.50	0.20	0.02	0.030	3.00	13.0	19.0	●	0.02-0.05

• For detailed cutting data, see pages 574-575

- ⁽¹⁾ Cutting width tolerance (+/-)

- ⁽²⁾ Corner radius tolerance (+/-)

- ⁽³⁾ Minimum penetration diameter

- ⁽⁴⁾ Maximum penetration diameter



MIFHR

Bars for Face and Internal Grooving, Undercutting and Threading Inserts

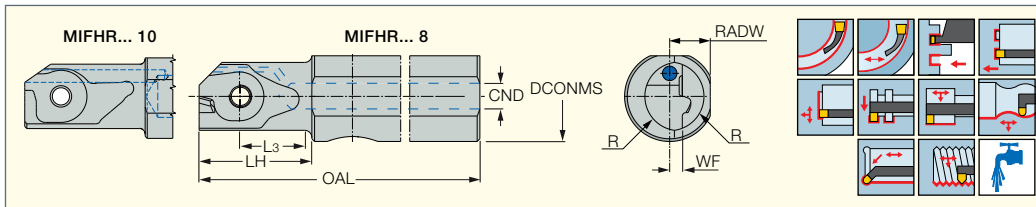

Designation	DCONMS	CND	WF	RADW	OAL	L ₃	LH	RE	Insert			
MIFHR 8SC-8-SRK ⁽¹⁾	8.00	1.2	1.4	3.70	75.00	7.40	11.7	3.80	MI.R 8	SR 14-297	T-8/5	
MIFHR 10C-8	10.00	5.0	1.4	4.50	102.50	7.40	12.5	3.80	MI.R 8	SR 14-297	T-8/5	
MIFHR 12C-10 ⁽²⁾	12.00	6.0	2.4	5.50	90.00	11.20	17.2	4.60	MI.R 10	SR 34-506	T-9/5	
MIFHR 12C-8	12.00	5.0	1.4	5.50	102.50	7.40	12.5	3.80	MI.R 8	SR 14-297	T-8/5	
MIFHR 16C-10 ⁽²⁾	16.00	6.0	2.4	7.50	90.00	11.20	17.2	4.60	MI.R 10	SR 34-506	T-9/5	
MIFHR 16C-15	16.00	8.0	2.7	7.50	100.00	12.50	19.0	10.30	MI.R 15	SR 34-506/L	T-9/5	PL 16
MIFHR 20C-15	20.00	8.5	4.7	9.00	100.00	12.50	19.0	11.30	MI.R 15	SR 34-506/L	T-9/5	PL 20

⁽¹⁾ Solid carbide shank

⁽²⁾ Only face grooving inserts are available for this tool

For inserts, see pages: MEFL (545) • MIFR (545) • MIGR 8 (374) • MITR 8-MT (375) • MIUR 8 (374)

For holders, see pages: PICCO/MG PCO (holder) (360)



MFHR-JHP

Square Shank Tools for MIFR 10 Face Grooving Inserts

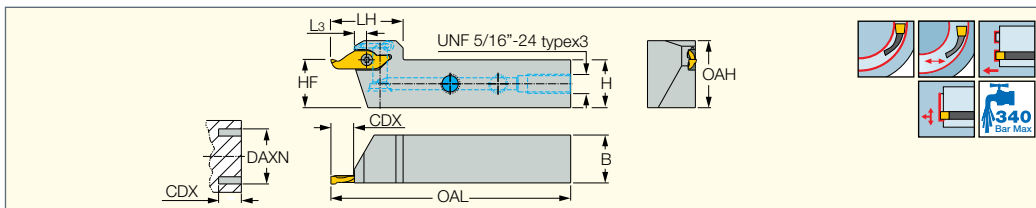

Designation	H	B	OAL	LH	L ₃	CDX	DAXN ⁽¹⁾	OAH	HF	Insert			
MFHR 12C-10-JHP	12.0	12.0	100.00	27.0	5.20	9.00	10.0	20.0	12.0	MI.R 10	SR 34-506	T-9/5	SR 5/16UNF TL360
MFHR 16C-10-JHP	16.0	16.0	100.00	27.0	5.20	9.00	10.0	24.0	16.0	MI.R 10	SR 34-506	T-9/5	SR 5/16UNF TL360
MFHR 20C-10-JHP	20.0	20.0	100.00	30.0	5.20	9.00	10.0	28.0	20.0	MI.R 10	SR 34-506	T-9/5	SR 5/16UNF TL360

• For D1max, refer to insert data • For user guide and accessories, see pages 572-584

⁽¹⁾ Minimum axial grooving diameter

For inserts, see pages: MIFR (545)

Flow Rate vs. Pressure

Designation	70 Bar	100 Bar	140 Bar
	Flow Rate (liters/min)	Flow Rate (liters/min)	Flow Rate (liters/min)
MFHR 12C-10-JHP	3	5-9	9-11
MFHR 16C-10-JHP	3	7-9	9-11



IHSR-MIFR

Trepanning Cartridges Carrying MINICUT Inserts Mounted on the BHR MB32-32X63 Boring Head

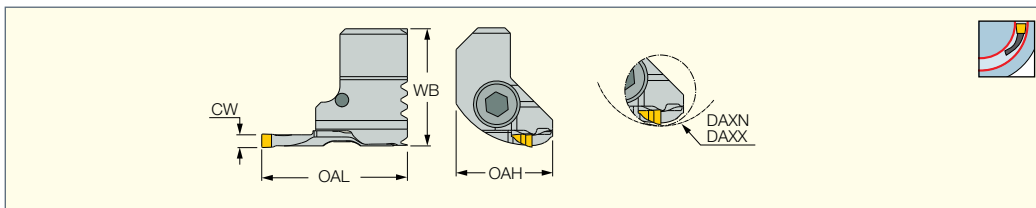

Designation	DAXN ⁽¹⁾	DAXX ⁽²⁾	CWN ⁽³⁾	CWX ⁽⁴⁾	OAL	WB	OAH	Insert			
IHSR 8-21 MIFR8	8.0	21.0	1.50	2.20	32.00	23.00	17.5	MI.R 8	SR 14-297	T-8/5	
IHSR 19-34 MIFR10	19.0	34.0	2.00	3.00	27.00	22.00	17.8	MI.R 10	SR 34-506	T-9/5	

⁽¹⁾ Minimum axial grooving diameter

⁽²⁾ Maximum axial grooving diameter

⁽³⁾ Minimum cutting width

⁽⁴⁾ Maximum cutting width

For inserts, see pages: MIFR (545)

MIFR

Screw-Clamped Inserts for Internal Face Grooving and Turning

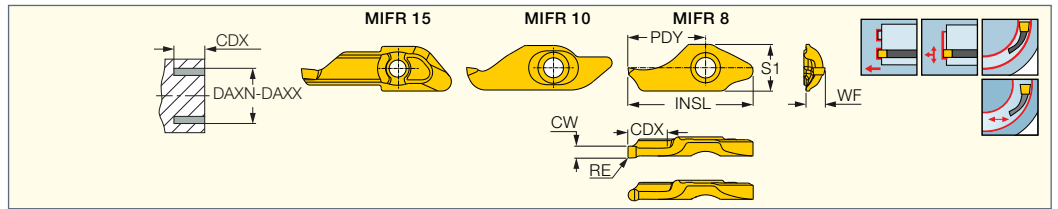

Designation	Dimensions											IC908	Recommended Machining Data	
	INSL	CW	CWTOL ⁽¹⁾	RE	RETOL ⁽²⁾	WF	S ₁	DAXN ⁽³⁾	DAXX ⁽⁴⁾	CDX	PDY		f face-groove (mm/rev)	f face-turn (mm/rev)
MIFR 8-1.50-0.20	17.70	1.50	0.02	0.20	0.020	2.60	6.5	8.0	11.5	5.50	11.00	●	0.02-0.10	0.02-0.06
MIFR 8-1.60-0.80	17.70	1.60	0.02	0.80	0.020	2.60	6.5	8.0	12.1	5.50	11.00	●	0.02-0.10	0.02-0.06
MIFR 8-2.00-0.20	17.70	2.00	0.02	0.20	0.020	2.80	6.5	8.0	16.0	5.50	11.00	●	0.02-0.10	0.02-0.06
MIFR 8-2.20-0.20	17.70	2.20	0.02	0.20	0.020	2.90	6.5	8.0	21.0	5.50	11.00	●	0.02-0.10	0.02-0.06
MIFR 10-2.00-0.20	25.10	2.00	0.02	0.20	0.020	3.00	7.6	10.0	-	9.00	14.80	●	0.02-0.10	0.02-0.06
MIFR 10-2.00-1.00	25.10	2.00	0.02	1.00	0.020	3.00	7.6	10.0	-	9.00	14.80	●	0.02-0.10	0.02-0.06
MIFR 10-2.50-0.20	25.10	2.50	0.02	0.20	0.020	3.10	7.6	10.0	30.0	9.00	14.80	●	0.02-0.10	0.02-0.06
MIFR 10-2.50-1.25	25.10	2.50	0.02	1.25	0.020	3.30	7.6	10.0	-	9.00	14.80	●	0.02-0.10	0.02-0.06
MIFR 10-3.00-0.20	25.10	3.00	0.02	0.20	0.020	3.40	7.6	10.0	30.0	9.00	14.80	●	0.02-0.10	0.02-0.06
MIFR 10-3.00-1.50	25.10	3.00	0.02	1.50	0.020	3.30	7.6	10.0	34.0	9.00	14.80	●	0.02-0.10	0.02-0.06
MIFR 15-2.50-0.20	30.00	2.50	0.02	0.20	0.020	5.55	9.0	15.0	60.0	15.00	19.30	●	0.03-0.05	0.03-0.04
MIFR 15-2.50-1.25	30.00	2.50	0.02	1.25	0.020	5.55	9.0	12.0	47.0	15.00	19.30	●	0.03-0.05	0.03-0.04
MIFR 15-3.00-0.20	30.00	3.00	0.02	0.20	0.020	5.85	9.0	15.0	60.0	15.00	19.30	●	0.03-0.05	0.03-0.04
MIFR 15-3.00-1.50	30.00	3.00	0.02	1.50	0.020	5.85	9.0	10.0	-	15.00	19.30	●	0.03-0.05	0.03-0.04
MIFR 15-3.50-0.20	30.00	3.50	0.02	0.20	0.020	6.00	9.0	10.0	-	15.00	19.30	●	0.03-0.05	0.03-0.04

• Recommended cutting speeds and feeds can be increased by 20-30% for aluminum, and reduced by 20-30% for titanium and Inconel
 • For cutting speed recommendations, see pages 574-575

- (1) Cutting width tolerance (+/-)
- (2) Corner radius tolerance (+/-)
- (3) Minimum axial grooving diameter
- (4) Maximum axial grooving diameter

For tools, see pages: IHSR-MIFR (544) • MFHR-JHP (544) • MIFHR (374)



MEFL

Screw-Clamped Inserts for External Face Grooving and Turning Next to Shafts

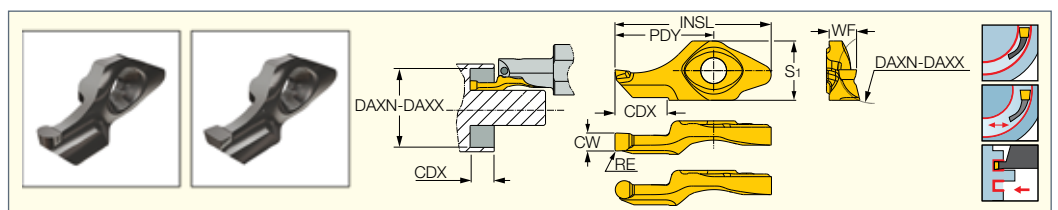

Designation	Dimensions											IC908	Recommended Machining Data	
	CW	RE	CWTOL ⁽¹⁾	RETOL ⁽²⁾	WF	S ₁	CDX	PDY	INSL	DAXN ⁽³⁾	DAXX ⁽⁴⁾		f face-groove (mm/rev)	f face-turn (mm/rev)
MEFL 8-1.50-0.20	1.50	0.20	0.02	0.020	2.60	6.6	5.50	11.00	17.40	8.0	15.0	●	0.02-0.10	0.02-0.06
MEFL 8-1.60-0.80	1.60	0.80	0.02	0.020	2.70	6.6	5.50	11.00	17.40	7.0	12.1	●	0.02-0.10	0.02-0.06
MEFL 8-2.00-0.20	2.00	0.20	0.02	0.020	3.10	6.6	5.50	11.00	17.40	7.0	20.0	●	0.02-0.10	0.02-0.06
MEFL 8-2.00-1.00	2.00	1.00	0.02	0.020	2.90	6.6	5.50	11.00	17.40	7.0	14.0	●	0.02-0.10	0.02-0.06
MEFL 8-2.20-0.20	2.20	0.20	0.02	0.020	3.10	6.6	5.50	11.00	17.40	7.0	20.0	●	0.02-0.10	0.02-0.06

• For cutting speed recommendations, see pages 574-575

- (1) Cutting width tolerance (+/-)
- (2) Corner radius tolerance (+/-)
- (3) Minimum axial grooving diameter
- (4) Maximum axial grooving diameter

For tools, see pages: MIFHR (374)



KIT MINICUT

Contains One Toolholder and a Set of 6 Different Inserts for Internal Face Grooving and Turning Applications



Designation	Qty
KIT MINICUT	7



HFFH

Face Grooving Blades

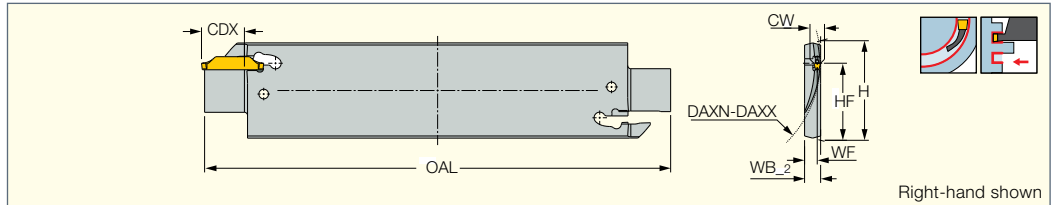

Designation	DAXN ⁽¹⁾	DAXX ⁽²⁾	CW	CDX	WF	WB_2	HF	H	OAL	
HFFH 38R/L-2	38.0	45.0	2.00	14.00	4.50	5.2	24.8	32.0	150.00	EDG 33B*
HFFH 45R/L-2	45.0	60.0	2.00	14.00	4.40	5.2	24.8	32.0	150.00	EDG 33B*
HFFH 60R/L-2	60.0	80.0	2.00	14.00	4.40	5.2	24.8	32.0	150.00	EDG 33B*
HFFH 80R/L-2	80.0	100.0	2.00	14.00	4.40	5.2	24.8	32.0	150.00	EDG 33B*
HFFH 100R/L-2	100.0	130.0	2.00	14.00	4.40	5.2	24.8	32.0	150.00	EDG 33B*

• B1 dimension links blades and blocks

⁽¹⁾ Minimum penetration diameter

⁽²⁾ Maximum penetration diameter

For inserts, see pages: HFPN (557)

For holders, see pages: C#-TBK-R/L (591) • HSK A-WH-TBK-R/L (598) • SGTBF (587) • SGTBK (587) • SGTBU/SGTBN (586) • UBHCR/L (587)



HFFA

Reinforced Face Grooving Blades

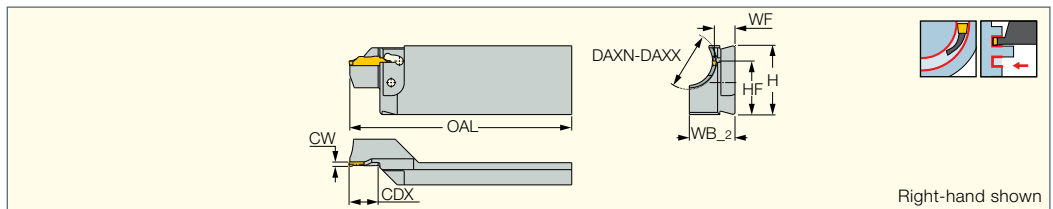

Designation	CW	DAXN ⁽¹⁾	DAXX ⁽²⁾	CDX	H	WF	HF	OAL	WB_2	
HFFA 27R/L-2	2.00	27.0	29.0	14.00	32.0	9.50	24.8	102.00	21.0	EDG 33B*
HFFA 29L-2	2.00	29.0	33.0	14.00	32.0	9.50	24.8	102.00	18.5	EDG 33B*
HFFA 33R/L-2	2.00	33.0	38.0	14.00	32.0	9.50	24.8	102.00	17.5	EDG 33B*
HFFA 38L-2	2.00	38.0	46.0	14.00	32.0	9.50	24.8	102.00	13.5	EDG 33B*
HFFA 46R/L-2	2.00	46.0	60.0	14.00	32.0	9.50	24.8	102.00	13.5	EDG 33B*
HFFA 60R/L-2	2.00	60.0	80.0	14.00	32.0	9.50	24.8	102.00	14.0	EDG 33B*
HFFA 80R/L-2	2.00	80.0	105.0	14.00	32.0	9.50	24.8	102.00	16.1	EDG 33B*

• For user guide, see pages 572-584

⁽¹⁾ Minimum penetration diameter

⁽²⁾ Maximum penetration diameter

For inserts, see pages: HFPN (557)

For holders, see pages: SGTBU/SGTBN (586) • UBHCR/L (587)

HGHR/L-3

Integral Holders for Face Grooving and Turning, DAXN. 12 mm

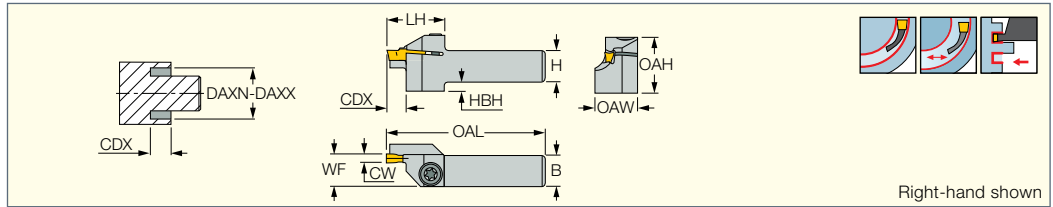

Designation	H	B	CW	CDX	HBH	WF	DAXN ⁽¹⁾	DAXX ⁽²⁾	OAL	LH	OAH	OAW		
HGHR/L 1010-12-3T6	10.0	10.0	3.00	6.00	2.0	9.50	12.0	16.0	120.00	19.0	19.0	13.70	SR 76-1400	T-20/3
HGHR 1010-16-3T6	10.0	10.0	3.00	6.00	2.0	9.50	16.0	25.0	120.00	19.0	19.0	12.80	SR 76-1400	T-20/3
HGHR/L 1212-12-3T6	12.0	12.0	3.00	6.00	-	11.00	12.0	16.0	120.00	19.0	19.0	15.70	SR 76-1400	T-20/3
HGHR 1212-16-3T6	12.0	12.0	3.00	6.00	-	11.00	16.0	25.0	120.00	19.0	19.0	14.80	SR 76-1400	T-20/3
HGHR/L 1616-12-3T6	16.0	16.0	3.00	6.00	-	15.00	12.0	16.0	120.00	19.0	21.0	19.70	SR 76-1400	T-20/3
HGHR/L 1616-16-3T6	16.0	16.0	3.00	6.00	-	15.00	16.0	25.0	120.00	19.0	21.0	18.80	SR 76-1400	T-20/3
HGHR/L 2020-12-3T6	20.0	20.0	3.00	6.00	-	20.00	12.0	16.0	120.00	19.0	25.0	24.00	SR 76-1400	T-20/3
HGHR/L 2020-16-3T6	20.0	20.0	3.00	6.00	-	20.00	16.0	25.0	120.00	19.0	25.0	24.00	SR 76-1400	T-20/3
HGHR/L 2525-12-3T6	25.0	25.0	3.00	6.00	-	25.00	12.0	16.0	120.00	19.0	30.0	29.00	SR 76-1400	T-20/3
HGHR/L 2525-16-3T6	25.0	25.0	3.00	6.00	-	25.00	16.0	25.0	120.00	19.0	30.0	29.00	SR 76-1400	T-20/3

• HGN & GRIP inserts can be used only with right-hand toolholders, HGPL inserts only with left-hand toolholders • For user guide, see pages 572-584

⁽¹⁾ Minimum penetration diameter

⁽²⁾ Maximum penetration diameter

For inserts, see pages: GRIP (254) • GRIP (full radius) (255) • HGN-C (445) • HGN-J (446) • HGN-UT (446) • HGPL (560)

No limitation for widening groove toward or away from center, except for the following tools:

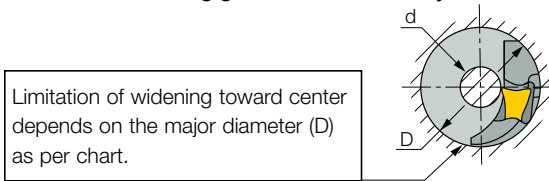

HGHR/L...-12-3T6

D	d
12.0	4.0
13.0	1.0
13.5	0

HFHR/L-3T

Integral Holders for Facing, DAXN. 25 mm

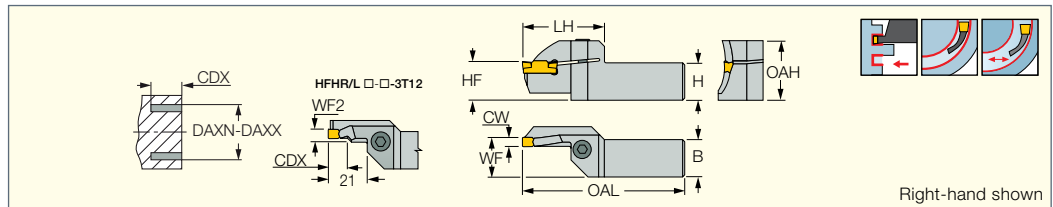

Designation	CW	CDX	H	HF	B	OAL	WF	WF ₂	DAXN ⁽²⁾	DAXX ⁽³⁾	LH	OAH		
HFHR/L 20-25-3T12	3.00	12.00	20.0	20.0	20.0	140.00	20.50	5.3	25.0	30.0	38.0	28.0	SR M6X16 DIN912	HW 5.0
HFHR/L 20-30-3T12	3.00	12.00	20.0	20.0	20.0	140.00	20.50	5.3	30.0	38.0	38.0	29.0	SR M6X16 DIN912	HW 5.0
HFHR/L 20-38-3T12	3.00	12.00	20.0	20.0	20.0	140.00	20.50	5.3	38.0	48.0	38.0	30.0	SR M6X16 DIN912	HW 5.0
HFHR/L 20-48-3T12	3.00	12.00	20.0	20.0	20.0	140.00	20.50	5.3	48.0	60.0	38.0	30.0	SR M6X16 DIN912	HW 5.0
HFHR/L 20-60-3T22 ⁽¹⁾	3.00	22.00	20.0	20.0	20.0	140.00	20.50	-	60.0	75.0	40.0	31.0	SR M6X16 DIN912	HW 5.0
HFHR/L 20-75-3T25 ⁽¹⁾	3.00	25.00	20.0	20.0	20.0	140.00	20.50	-	75.0	100.0	43.0	31.0	SR M6X16 DIN912	HW 5.0
HFHR/L 25-25-3T12	3.00	12.00	25.0	25.0	25.0	150.00	25.50	5.3	25.0	30.0	38.0	33.0	SR M6X16 DIN912	HW 5.0
HFHR/L 25-30-3T12	3.00	12.00	25.0	25.0	25.0	150.00	25.50	5.3	30.0	38.0	38.0	34.0	SR M6X16 DIN912	HW 5.0
HFHR/L 25-38-3T12	3.00	12.00	25.0	25.0	25.0	150.00	25.50	5.3	38.0	48.0	38.0	35.0	SR M6X16 DIN912	HW 5.0
HFHR/L 25-48-3T22 ⁽¹⁾	3.00	22.00	25.0	25.0	25.0	150.00	25.50	-	48.0	60.0	40.0	36.0	SR M6X16 DIN912	HW 5.0
HFHR/L 25-60-3T22 ⁽¹⁾	3.00	22.00	25.0	25.0	25.0	150.00	25.50	-	60.0	75.0	40.0	36.0	SR M6X16 DIN912	HW 5.0
HFHR/L 25-75-3T25 ⁽¹⁾	3.00	25.00	25.0	25.0	25.0	150.00	25.50	-	75.0	100.0	43.0	36.0	SR M6X16 DIN912	HW 5.0

• For user guide, see pages 572-584

⁽¹⁾ For deep face grooving only.

⁽²⁾ Minimum penetration diameter

⁽³⁾ Maximum penetration diameter

No limitation for widening groove toward or away from center, except for the following tools:

HFHR/L-:-25-3T12

D	d
25	5
26	2
≥27	0

HFHR/L-:-25-4T12

D	d
25	1
≥26	0

HFHR/L-:-29-4T12

D	d
29	1
≥46	0

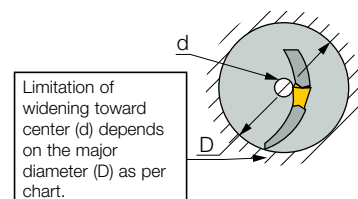

HELIFACE

HFHR/L-4T

Integral Holders for Facing, DAXN. 25 mm

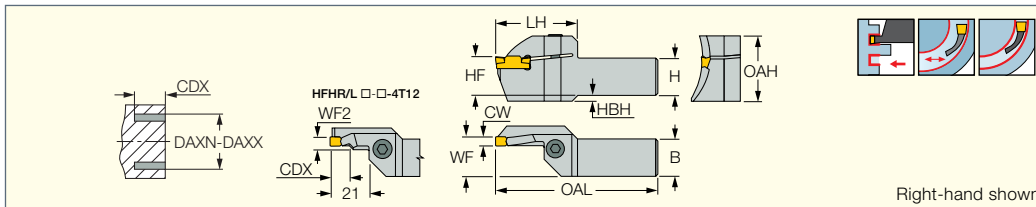

Designation	CW	CDX	H	HF	B	OAL	WF	WF ₂	DAXN ⁽¹⁾	DAXX ⁽²⁾	LH	OAH	HBH		
HFHR/L 20-25-4T12	4.00	12.00	20.0	20.0	20.0	140.00	20.60	6.2	25.0	29.0	39.0	29.0	-	SR M6X16 DIN912	HW 5.0
HFHR/L 20-29-4T12	4.00	12.00	20.0	20.0	20.0	140.00	20.60	6.2	29.0	34.0	39.0	30.0	-	SR M6X16 DIN912	HW 5.0
HFHR/L 20-34-4T20	4.00	20.00	20.0	20.0	20.0	140.00	20.60	-	34.0	40.0	39.0	30.0	-	SR M6X16 DIN912	HW 5.0
HFHR/L 20-40-4T25	4.00	25.00	20.0	20.0	20.0	140.00	20.60	-	40.0	48.0	44.0	31.0	-	SR M6X16 DIN912	HW 5.0
HFHR/L 20-48-4T25	4.00	25.00	20.0	20.0	20.0	140.00	20.60	-	48.0	60.0	44.0	32.0	-	SR M6X16 DIN912	HW 5.0
HFHR/L 20-60-4T25	4.00	25.00	20.0	20.0	20.0	140.00	20.60	-	60.0	75.0	44.0	32.0	-	SR M6X16 DIN912	HW 5.0
HFHR/L 20-75-4T25	4.00	25.00	20.0	20.0	20.0	140.00	20.60	-	75.0	100.0	44.0	34.0	2.0	SR M6X16 DIN912	HW 5.0
HFHR/L 25-100-4T25	4.00	25.00	25.0	25.0	25.0	150.00	25.60	-	100.0	140.0	44.0	37.0	-	SR M6X16 DIN912	HW 5.0
HFHR/L 25-140-4T25	4.00	25.00	25.0	25.0	25.0	150.00	25.60	-	140.0	240.0	44.0	37.0	-	SR M6X16 DIN912	HW 5.0
HFHR/L 25-240-4T25	4.00	25.00	25.0	25.0	25.0	150.00	25.60	-	240.0	800.0	44.0	37.0	-	SR M6X16 DIN912	HW 5.0
HFHR/L 25-25-4T12	4.00	12.00	25.0	25.0	25.0	150.00	25.60	6.2	25.0	29.0	39.0	34.0	-	SR M6X16 DIN912	HW 5.0
HFHR/L 25-29-4T12	4.00	12.00	25.0	25.0	25.0	150.00	25.60	6.2	29.0	34.0	39.0	35.0	-	SR M6X16 DIN912	HW 5.0
HFHR/L 25-34-4T20	4.00	20.00	25.0	25.0	25.0	150.00	25.60	-	34.0	40.0	39.0	35.0	-	SR M6X16 DIN912	HW 5.0
HFHR/L 25-40-4T25	4.00	25.00	25.0	25.0	25.0	150.00	25.60	-	40.0	48.0	44.0	36.0	-	SR M6X16 DIN912	HW 5.0
HFHR/L 25-48-4T25	4.00	25.00	25.0	25.0	25.0	150.00	25.60	-	48.0	60.0	44.0	37.0	-	SR M6X16 DIN912	HW 5.0
HFHR/L 25-60-4T25	4.00	25.00	25.0	25.0	25.0	150.00	25.60	-	60.0	75.0	44.0	37.0	-	SR M6X16 DIN912	HW 5.0
HFHR/L 25-75-4T25	4.00	25.00	25.0	25.0	25.0	150.00	25.60	-	75.0	100.0	44.0	37.0	-	SR M6X16 DIN912	HW 5.0

• DGN & GRIP 4 mm inserts can be used only with right-hand tools, HGPL 4 mm with left-hand tools • For user guide, see pages 572-584

⁽¹⁾ Minimum penetration diameter
⁽²⁾ Maximum penetration diameter

Penetration Range
HFHR/L-:-25-4T12

D	d
25	1
≥26	0

HFHR/L-:-29-4T12

D	d
29	1
≥46	0

Limitation of widening toward center (d depends on the major diameter (D) as per chart

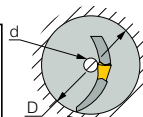

HELIFACE

HFHR/L-5T

Integral Holders for Facing, DAXN. 25 mm

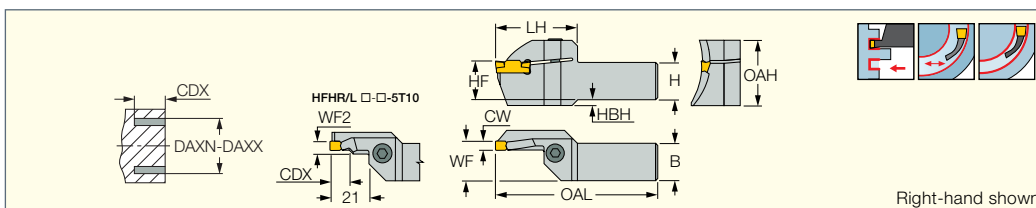

Designation	CW	CDX	H	HF	B	OAL	WF ₂	WF	DAXN ⁽¹⁾	DAXX ⁽²⁾	LH	OAH	HBH		
HFHR/L 20-25-5T10	5.00	10.00	20.0	20.0	20.0	140.00	7.1	21.00	25.0	30.0	38.0	28.0	-	SR M6X16 DIN912	HW 5.0
HFHR/L 20-28-5T15	5.00	17.00	20.0	20.0	20.0	140.00	-	21.00	28.0	31.0	34.0	30.0	-	SR M6X16 DIN912	HW 5.0
HFHR/L 20-31-5T15	5.00	17.00	20.0	20.0	20.0	140.00	-	21.00	31.0	35.0	34.0	30.0	-	SR M6X16 DIN912	HW 5.0
HFHR/L 20-35-5T20	5.00	20.00	20.0	20.0	20.0	140.00	-	21.00	35.0	40.0	39.0	31.0	-	SR M6X16 DIN912	HW 5.0
HFHR/L 20-40-5T20	5.00	20.00	20.0	20.0	20.0	140.00	-	21.00	40.0	45.0	39.0	31.0	-	SR M6X16 DIN912	HW 5.0
HFHR/L 20-45-5T25	5.00	25.00	20.0	20.0	20.0	140.00	-	21.00	45.0	55.0	44.0	32.0	-	SR M6X16 DIN912	HW 5.0
HFHR/L 20-55-5T25	5.00	25.00	20.0	20.0	20.0	140.00	-	21.00	55.0	70.0	44.0	35.0	3.0	SR M6X16 DIN912	HW 5.0
HFHR/L 20-70-5T28	5.00	28.00	20.0	20.0	20.0	140.00	-	21.00	70.0	95.0	47.0	35.0	3.0	SR M6X16 DIN912	HW 5.0
HFHR/L 25-110-5T14	5.00	14.00	25.0	25.0	25.0	150.00	-	23.50	110.0	200.0	32.5	33.0	-	SR M6X16 DIN912	HW 5.0
HFHR/L 25-130-5T32	5.00	32.00	25.0	25.0	25.0	150.00	-	26.00	130.0	180.0	51.0	37.0	-	SR M6X16 DIN912	HW 5.0
HFHR/L 25-180-5T32	5.00	32.00	25.0	25.0	25.0	150.00	-	26.00	180.0	800.0	51.0	37.0	-	SR M6X16 DIN912	HW 5.0
HFHR/L 25-200-5T20	5.00	20.00	25.0	25.0	25.0	150.00	-	23.50	200.0	800.0	32.5	33.0	-	SR M6X16 DIN912	HW 5.0
HFHR/L 25-25-5T10	5.00	10.00	25.0	25.0	25.0	150.00	7.1	26.00	25.0	30.0	38.0	33.0	-	SR M6X16 DIN912	HW 5.0
HFHR/L 25-28-5T15	5.00	17.00	25.0	25.0	25.0	150.00	-	26.00	28.0	31.0	34.0	35.0	-	SR M6X16 DIN912	HW 5.0
HFHR/L 25-31-5T15	5.00	17.00	25.0	25.0	25.0	150.00	-	26.00	31.0	35.0	34.0	35.0	-	SR M6X16 DIN912	HW 5.0
HFHR/L 25-35-5T20	5.00	20.00	25.0	25.0	25.0	150.00	-	26.00	35.0	40.0	39.0	36.0	-	SR M6X16 DIN912	HW 5.0
HFHR/L 25-40-5T20	5.00	20.00	25.0	25.0	25.0	140.00	-	26.00	40.0	45.0	39.0	36.0	-	SR M6X16 DIN912	HW 5.0
HFHR/L 25-45-5T25	5.00	25.00	25.0	25.0	25.0	150.00	-	26.00	45.0	55.0	44.0	37.0	-	SR M6X16 DIN912	HW 5.0
HFHR/L 25-52-5T14	5.00	14.00	25.0	25.0	25.0	150.00	-	23.50	52.0	75.0	32.5	33.0	-	SR M6X16 DIN912	HW 5.0
HFHR/L 25-55-5T25	5.00	25.00	25.0	25.0	25.0	150.00	-	26.00	55.0	70.0	44.0	37.0	-	SR M6X16 DIN912	HW 5.0
HFHR/L 25-70-5T32	5.00	32.00	25.0	25.0	25.0	150.00	-	26.00	70.0	95.0	51.0	37.0	-	SR M6X16 DIN912	HW 5.0
HFHR/L 25-75-5T14	5.00	14.00	25.0	25.0	25.0	150.00	-	23.50	75.0	110.0	32.5	33.0	-	SR M6X16 DIN912	HW 5.0
HFHR/L 25-95-5T32	5.00	32.00	25.0	25.0	25.0	150.00	-	26.00	95.0	130.0	51.0	37.0	-	SR M6X16 DIN912	HW 5.0

• DGN & GRIP 5.. inserts can be used only with right-hand tools, HGPL 5.. inserts with left-hand tools • For user guide, see pages 572-584

⁽¹⁾ Minimum penetration diameter
⁽²⁾ Maximum penetration diameter

No limitation for widening groove toward or away from center, except for the following tools:

HFHR/L-□-31-5T15

D	d
31	15
32	10
33	7
34	4
35	2
≥36	0

HFHR/L-□-30-6T10

D	d
30	7
31	4
32	1
≥33	0

HFHR/L-□-25-5T10

D	d
25	4
26	1
≥27	0

HFHR/L-□-28-5T15

D	d
28	13
29	8
30	5
31	3
32	1
≥33	0

Limitation of widening toward center (d) depends on the major diameter (D) as per chart

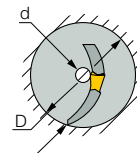

HFHR/L-6T

Integral Holders for Facing, DAXN. 26 mm

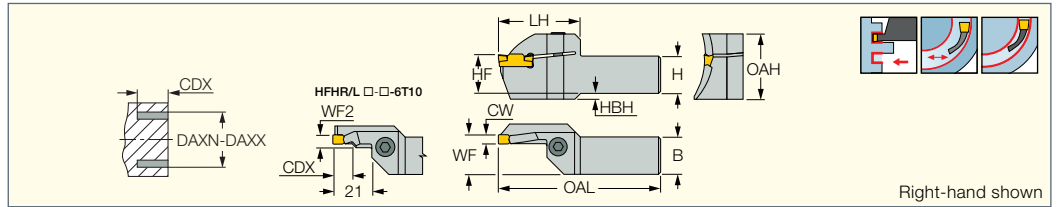

Designation	CW	CDX	H	HF	B	OAL	WF ₂	WF	DAXN ⁽¹⁾	DAXX ⁽²⁾	LH	OAH	HBH		
HFHL 20-26-6T10	6.00	10.00	20.0	20.0	20.0	140.00	7.9	21.40	26.0	30.0	39.0	29.0	-	SR M6X16 DIN912	HW 5.0
HFHR/L 20-30-6T15	6.00	17.00	20.0	20.0	20.0	140.00	-	21.40	30.0	38.0	36.0	30.0	-	SR M6X16 DIN912	HW 5.0
HFHR/L 20-38-6T20	6.00	20.00	20.0	20.0	20.0	140.00	-	21.40	38.0	50.0	39.0	31.0	-	SR M6X16 DIN912	HW 5.0
HFHR/L 20-50-6T25	6.00	25.00	20.0	20.0	20.0	140.00	-	21.40	50.0	70.0	44.0	32.0	-	SR M6X16 DIN912	HW 5.0
HFHR/L 25-100-6T20	6.00	20.00	25.0	25.0	25.0	150.00	-	26.00	100.0	200.0	40.0	33.0	-	SR M6X16 DIN912	HW 5.0
HFHR/L 25-100-6T32	6.00	32.00	25.0	25.0	25.0	150.00	-	26.40	100.0	180.0	51.0	37.0	-	SR M6X16 DIN912	HW 5.0
HFHR/L 25-180-6T32	6.00	32.00	25.0	25.0	25.0	150.00	-	26.40	180.0	400.0	51.0	40.0	3.0	SR M6X16 DIN912	HW 5.0
HFHR/L 25-200-6T20	6.00	20.00	25.0	25.0	25.0	150.00	-	23.00	200.0	3000.0	37.5	33.0	-	SR M6X16 DIN912	HW 5.0
HFHR/L 25-30-6T15	6.00	17.00	25.0	25.0	25.0	150.00	-	26.40	30.0	38.0	36.0	35.0	-	SR M6X16 DIN912	HW 5.0
HFHR/L 25-38-6T20	6.00	20.00	25.0	25.0	25.0	150.00	-	26.40	38.0	50.0	39.0	36.0	-	SR M6X16 DIN912	HW 5.0
HFHR/L 25-400-6T32	6.00	32.00	25.0	25.0	25.0	150.00	-	26.40	400.0	3000.0	51.0	40.0	3.0	SR M6X16 DIN912	HW 5.0
HFHR/L 25-50-6T20	6.00	20.00	25.0	25.0	25.0	150.00	-	23.00	50.0	65.0	37.5	33.0	-	SR M6X16 DIN912	HW 5.0
HFHR/L 25-50-6T25	6.00	25.00	25.0	25.0	25.0	150.00	-	26.40	50.0	70.0	44.0	37.0	-	SR M6X16 DIN912	HW 5.0
HFHR/L 25-65-6T20	6.00	20.00	25.0	25.0	25.0	150.00	-	23.00	65.0	100.0	37.5	33.0	-	SR M6X16 DIN912	HW 5.0
HFHR/L 25-70-6T32	6.00	32.00	25.0	25.0	25.0	150.00	-	26.40	70.0	100.0	51.0	37.0	-	SR M6X16 DIN912	HW 5.0

• DGN & GRIP 6.. inserts can be used only with right-hand tools, HGPL 6.. inserts with left-hand tools • For user guide, see pages 572-584

- (1) Minimum penetration diameter
- (2) Maximum penetration diameter

No limitation for widening groove toward or away from center, except for the following tools:

HFHR/L-□-30-6T10

D	d
30	7
31	4
32	1
≥33	0

Limitation of widening toward center (d) depends on the major diameter (D) as per chart

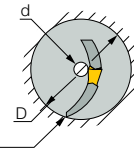

MODULARGRIP

HFPAD-3

Adapters for Face Machining

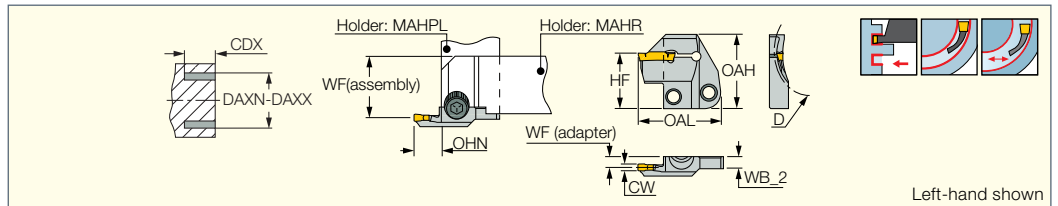

Designation	DAXN ⁽¹⁾	DAXX ⁽²⁾	CW	CDX	OHN ⁽³⁾	WF ⁽⁴⁾	WB_2	OAL	HF
HFPAD 3R/L-25-T10	25.0	30.0	3.00	10.00	15.0	4.80	5.8	39.50	24.0
HFPAD 3R/L-30-T10	30.0	40.0	3.00	10.00	15.0	4.80	5.8	39.50	24.0
HFPAD 3R/L-40-T10	40.0	65.0	3.00	10.00	15.0	4.80	5.8	39.50	24.0
HFPAD 3R/L-65-T18	65.0	115.0	3.00	18.00	19.0	4.80	5.8	43.50	24.0
HFPAD 3R/L-115-T18	115.0	400.0	3.00	18.00	19.0	4.80	5.8	43.50	24.0

• WF(assembly)=WF(shank) + WF(adapter) • HGN & GRIP 3.. inserts can be used only with right-hand adapters, HGPL 3.. inserts with left-hand adapters

• For user guide, see pages 572-584

- (1) Minimum penetration diameter
- (2) Maximum penetration diameter
- (3) Minimum overhang
- (4) WF(adapter)

MODULARGRIP

HFPAD-4

Adapters for Face Machining

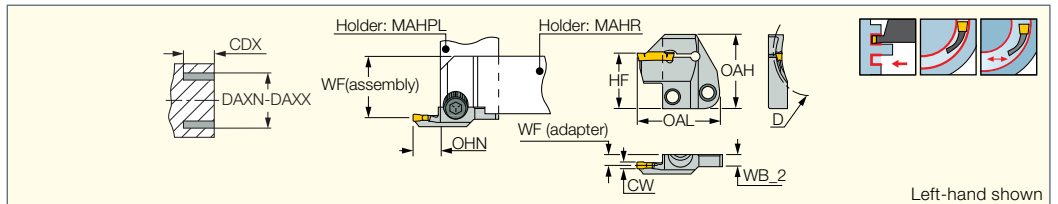

Designation	DAXN ⁽¹⁾	DAXX ⁽²⁾	CW	CDX	OHN ⁽³⁾	WF ⁽⁴⁾	WB_2	OAL	HF
HFPAD 4R/L-25-T10	25.0	31.0	4.00	10.00	16.0	4.50	5.8	40.50	24.0
HFPAD 4R/L-31-T10	31.0	44.0	4.00	10.00	16.0	4.50	5.8	40.50	24.0
HFPAD 4R/L-44-T14	44.0	58.0	4.00	14.00	16.0	4.50	5.8	40.50	24.0
HFPAD 4R/L-58-T14	58.0	88.0	4.00	14.00	16.0	4.50	5.8	40.50	24.0
HFPAD 4R/L-88-T14	88.0	175.0	4.00	14.00	16.0	4.50	5.8	40.50	24.0
HFPAD 4R/L-175-T20	175.0	800.0	4.00	20.00	21.0	4.50	6.5	45.50	24.0

• WF(assembly)=WF(shank) + WF(adapter) • DGN & GRIP 4.. inserts can be used only with right-hand adapters, HGPL 4.. inserts with left-hand adapters

• For user guide, see pages 572-584

- (1) Minimum penetration diameter
- (2) Maximum penetration diameter
- (3) Minimum overhang
- (4) WF(adapter)

MODULAR GRIP

HFPAD-5

Adapters for Face Machining

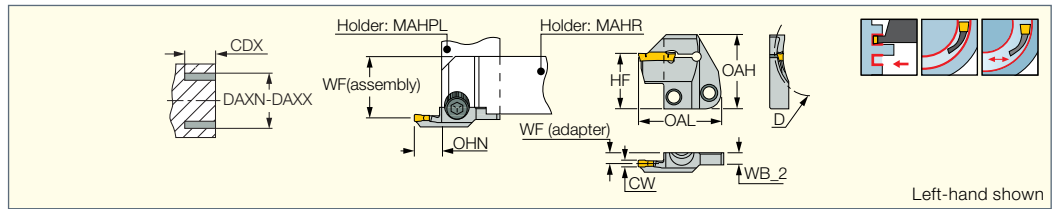

Left-hand shown

Designation	DAXN ⁽¹⁾	DAXX ⁽²⁾	CW	CDX	OHN ⁽³⁾	WF ⁽⁴⁾	WB_2	OAL	HF	OAH
HFPAD 5R/L-40-T14	40.0	50.0	5.00	14.00	16.0	4.50	6.3	40.50	24.0	32.0
HFPAD 5R/L-50-T14	50.0	75.0	5.00	14.00	16.0	4.50	6.3	40.50	24.0	32.0
HFPAD 5R/L-75-T14	75.0	110.0	5.00	14.00	16.0	4.50	6.3	40.50	24.0	32.0
HFPAD 5R/L-110-T14	110.0	200.0	5.00	14.00	16.0	4.50	6.3	40.50	24.0	32.0
HFPAD 5R/L-200-T20	200.0	800.0	5.00	20.00	21.0	4.50	6.6	45.50	24.0	32.0

- WF(assembly)=WF(shank) + WF(adapter) • DGN & GRIP 5.. inserts can be used only with right-hand adapters, HGPL 5.. inserts with left-hand adapters
- For user guide, see pages 572-584
- (1) Minimum penetration diameter
- (2) Maximum penetration diameter
- (3) Minimum overhang
- (4) WF(adapter)

MODULAR GRIP

HFPAD-6

Adapters for Face Machining

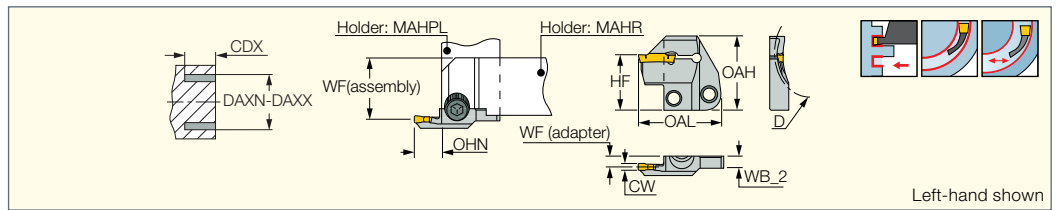

Left-hand shown

Designation	DAXN ⁽¹⁾	DAXX ⁽²⁾	CW	CDX	OHN ⁽³⁾	WF ⁽⁴⁾	WB_2	OAL	HF	OAH
HFPAD 6R/L-60-T14	60.0	100.0	6.00	14.00	16.0	4.50	6.8	40.50	24.0	32.0
HFPAD 6R/L-100-T20	100.0	200.0	6.00	20.00	21.0	4.50	6.8	45.50	24.0	32.0
HFPAD 6R/L-200-T20	200.0	3000.0	6.00	20.00	21.0	4.50	7.1	45.50	24.0	32.0

- WF(assembly)=WF(shank) + WF(adapter) • DGN & GRIP 6.. inserts can be used only with right-hand adapters, HGPL 6.. inserts with left-hand adapters
- For user guide, see pages 572-584
- (1) Minimum penetration diameter
- (2) Maximum penetration diameter
- (3) Minimum overhang
- (4) WF(adapter)

HELI FACE

HFFR/L-T

Blades for Face Machining

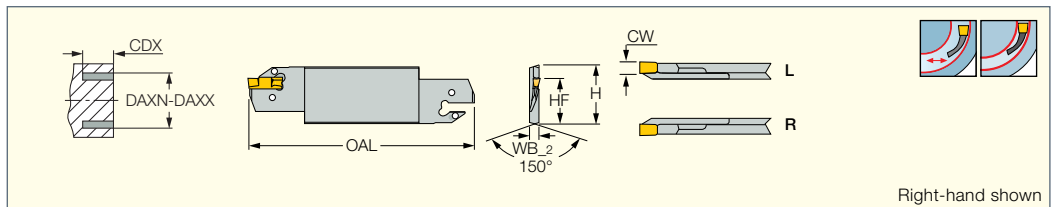

Right-hand shown

Designation	CW	DAXN ⁽²⁾	DAXX ⁽³⁾	CDX	OAL	HF	H	WB_2	
HFFR/L 48-4T25 ⁽¹⁾	4.00	48.0	60.0	25.00	150.00	24.8	32.0	5.2	EDG 33B*
HFFR/L 60-4T25	4.00	60.0	75.0	25.00	150.00	24.8	32.0	5.2	EDG 33B*
HFFR/L 75-4T30	4.00	75.0	140.0	30.00	150.00	24.8	32.0	5.2	EDG 33B*
HFFR/L 140-4T30	4.00	140.0	1500.0	30.00	150.00	24.8	32.0	3.2	EDG 33B*
HFFR/L 70-5T32	5.00	70.0	95.0	32.00	150.00	24.8	32.0	5.2	EDG 33B*
HFFR/L 95-5T35	5.00	95.0	130.0	35.00	150.00	24.8	32.0	5.2	EDG 33B*
HFFR/L 130-5T38	5.00	130.0	180.0	38.00	150.00	24.8	32.0	5.2	EDG 33B*
HFFR/L 180-5T38	5.00	180.0	1500.0	38.00	150.00	24.8	32.0	4.0	EDG 33B*
HFFR/L 90-6T32	6.00	90.0	180.0	32.00	150.00	24.8	32.0	5.2	EDG 33B*
HFFR/L 180-6T38	6.00	180.0	400.0	38.00	150.00	24.8	32.0	5.2	EDG 33B*

- After initial groove, no limitation to widening groove outward or toward center. • DGN & GRIP inserts can be used only with right-hand adapters, HGPL inserts with left-hand blades • For user guide, see pages 572-584
- (1) HGPL 4...Y with LH blade.
- (2) Minimum penetration diameter
- (3) Maximum penetration diameter
- * Optional, should be ordered separately

HELIFACE

HAR/L

Face Machining Adapter Holders

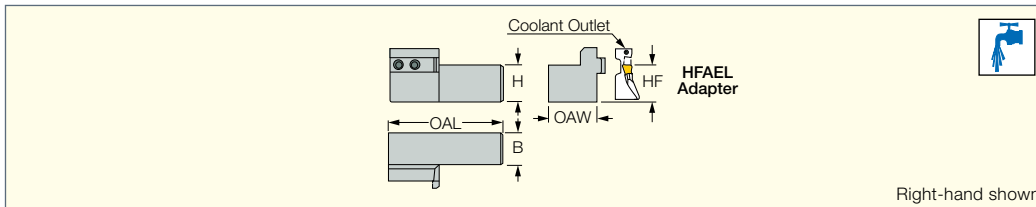

Designation	OAL	B	H	HF	OAW		
HAR/L 25C	110.00	25.0	25.0	25.0	39.00	SR 14-519	T-20/3
HAR/L 32C	130.00	32.0	32.0	32.0	46.00	SR 14-519	T-20/3

• Holders for adapters HFAER/L & HGAER/L, HFAIR/L & HGAIR/L

HELIFACE

HAPR/L

Face Machining Perpendicular Holders for Adapters

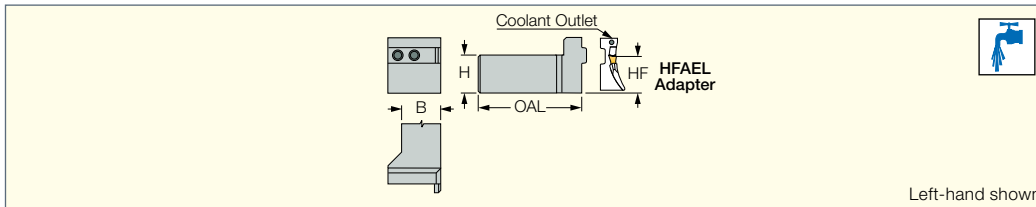

Designation	OAL	H	HF	B		
HAPR/L 25C	124.00	25.0	25.0	25.0	SR 14-519	T-20/3
HAPR/L 32C	139.00	32.0	32.0	32.0	SR 14-519	T-20/3

• Holders for adapters HFAER/L & HGAER/L, HFAIR/L & HGAIR/L.

HELIFACE

HGAER/L-3

Adapters for External Facing Along Shafts

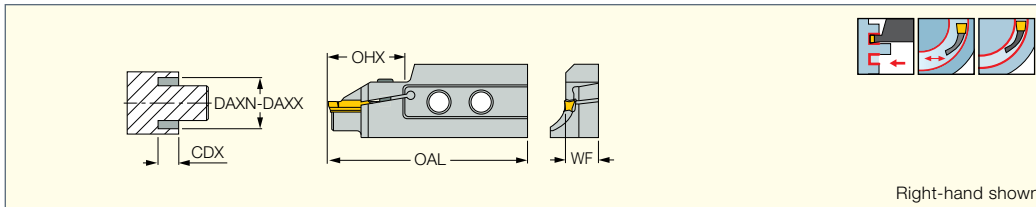

Designation	CDX	CW	DAXN ⁽¹⁾	DAXX ⁽²⁾	OHX ⁽³⁾	WF	OAL		
HGAER/L 12-3M	2.00	3.00	12.0	500.0	21.0	10.2	55.00	SR 16-236 P	T-15/5
HGAER/L 12-3T6	6.00	3.00	12.0	15.0	21.0	10.2	55.00	SR 16-236 P	T-15/5
HGAER/L 14-3T7	7.00	3.00	14.0	17.0	21.0	10.2	55.00	SR 16-236 P	T-15/5
HGAER/L 17-3T8	8.00	3.00	17.0	21.0	21.0	10.2	55.00	SR 16-236 P	T-15/5
HGAER/L 21-3T9	9.00	3.00	21.0	25.0	21.0	10.2	55.00	SR 16-236 P	T-15/3

• GRIP 3... inserts can be used with right-hand adapters only, HGPL 3 with left-hand adapters • For user guide, see pages 572-584

- ⁽¹⁾ Minimum penetration diameter
- ⁽²⁾ Maximum penetration diameter
- ⁽³⁾ Maximum overhang

HELIFACE

HFAER/L-4

Adapters for External Facing Along Shafts

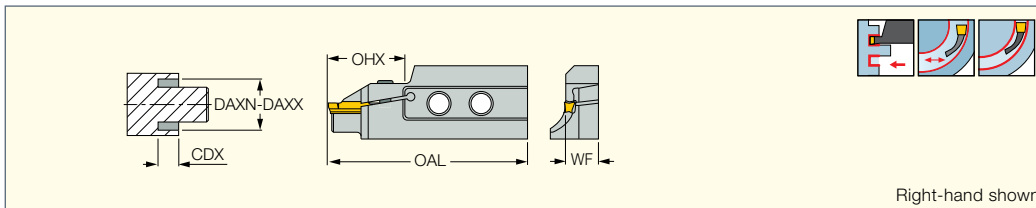

Designation	CDX	CW	DAXN ⁽¹⁾	DAXX ⁽²⁾	OAL	OHX ⁽³⁾	WF		
HFAER/L 40-4T20	20.00	4.00	40.0	48.0	68.50	21.0	11.6	SR M5X16 DIN912	HW 4.0
HFAER/L 48-4T20	20.00	4.00	48.0	60.0	68.50	21.0	11.6	SR M5X16 DIN912	HW 4.0
HFAER/L 60-4T25	25.00	4.00	60.0	75.0	68.50	26.0	11.6	SR M5X16 DIN912	HW 4.0
HFAER/L 75-4T25	25.00	4.00	75.0	100.0	68.50	26.0	11.6	SR M5X16 DIN912	HW 4.0

• DGN & GRIP inserts can be used only with right-hand adapters, HGPL inserts with left-hand blades • For user guide, see pages 572-584

- ⁽¹⁾ Minimum penetration diameter
- ⁽²⁾ Maximum penetration diameter
- ⁽³⁾ Maximum overhang

For inserts, see pages: DGN-MF (442) • HFPR/L (558) • HFPR/L (full radius) (558) • GRIP (254) • GRIP (full radius) (255) • DGN/DGNC/DGNM-C (438) • DGN/DGNM-J/JT/JT (440) • HGPL (560)

For holders, see pages: C#-HAD (595) • C#-HAPR/L (595) • HAPR/L (551) • HAR/L (551) • IM-HAD (600) • IM-HAPR/L (600)

HELIFACE

HFAER/L-5T, 6T

Adapters for External Facing Along Shafts

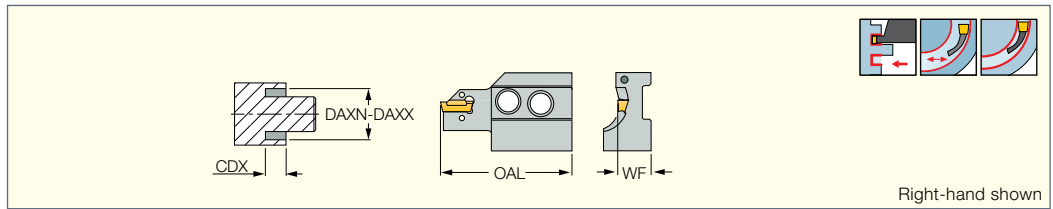

Designation	CW	CDX	DAXN ⁽¹⁾	DAXX ⁽²⁾	OAL	WF	
HFAER/L 70C-5T25	5.00	25.00	70.0	95.0	66.00	12.2	EDG 33B*
HFAER/L 95C-5T25	5.00	25.00	95.0	130.0	66.00	12.2	EDG 33B*
HFAER/L 70C-6T28	6.00	28.00	70.0	100.0	69.00	12.3	EDG 33B*
HFAER/L 100C-6T32	6.00	32.00	100.0	180.0	73.00	12.3	EDG 33B*
HFAER/L 180C-6T32	6.00	32.00	180.0	400.0	73.00	12.3	EDG 33B*

- After initial groove, no limitation to widening groove outward from or toward center
- Adapters can be mounted on standard HAR/L, HAPR/L, HAI holders for external machining
- DGN & GRIP inserts can be used only with right-hand adapters, HGPL inserts with left-hand blades
- For user guide, see pages 572-584

⁽¹⁾ Minimum penetration diameter
⁽²⁾ Maximum penetration diameter

* Optional, should be ordered separately

For inserts, see pages: HFPR/L (558) • HFPR/L (full radius) (558) • GRIP (254) • GRIP (full radius) (255) • DGN/DGNC/DGNM-C (438) • DGN/DGNM-J/JS/JT (440) • DGN-W (439) • HGPL (560)

For holders, see pages: C#-HAD (595) • C#-HAPR/L (595) • HAPR/L (551) • HAR/L (551) • IM-HAD (600) • IM-HAPR/L (600)

HELIFACE

HFHR/L-M

Toolholders for Shallow Face Grooving

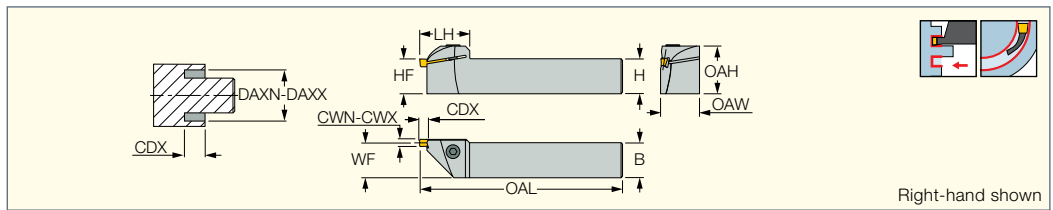

Designation	CWN ⁽¹⁾	CWX ⁽²⁾	CDX	WF	H	HF	B	OAL	DAXN ⁽³⁾	DAXX ⁽⁴⁾	OAH	OAW		
HFHR/L 20M	3.00	6.00	5.30	20.00	20.0	20.0	20.0	130.00	20.0	2000.0	29.0	22.50	SR M6X16 DIN912	HW 5.0
HFHR/L 25M	3.00	6.00	5.30	25.00	25.0	25.0	25.0	150.00	20.0	2000.0	34.0	27.50	SR M6X16 DIN912	HW 5.0

- DGN & GRIP 4.. - 6.. inserts can be used only with right-hand tools, HGPL 4.. - 6.. inserts with left-hand tools
- After initial groove, no limitation to widening groove outward or toward center
- For user guide, see pages 572-584

⁽¹⁾ Minimum cutting width
⁽²⁾ Maximum cutting width
⁽³⁾ Minimum penetration diameter
⁽⁴⁾ Maximum penetration diameter

HFHR/L-□M & HFHPR/L-□M

Integral Toolholders

For shallow machining up to max. 5 mm depth of groove. One toolholder can be mounted with inserts in 3-6 mm widths.

The initial major diameter groove is limited by the insert geometry in each size.

After initial groove, face recessing outward or toward center is not limited by insert geometry.

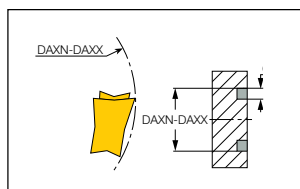
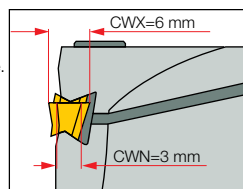

Insert initial face grooving range

DAXN-DAXX		
CW	DAXN	DAXX
3	25.6	51.5
4	24.1	73.7
5	22.1	170
6	20.8	∞

HELIFACE

HFHPR/L-M

Perpendicular Toolholders for Shallow Face Grooving

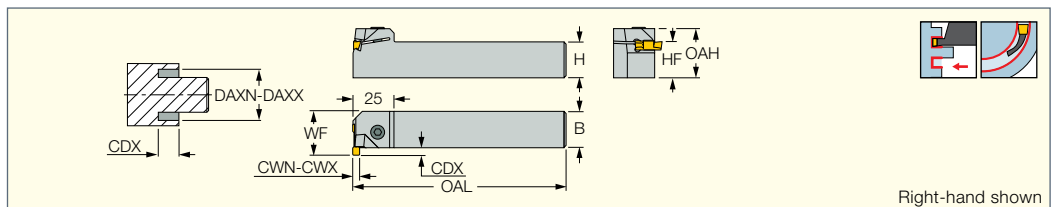

Designation	CWN ⁽¹⁾	CWX ⁽²⁾	CDX	WF	H	B	OAL	DAXN ⁽³⁾	DAXX ⁽⁴⁾	OAH	HF		
HFHPR/L 20M	3.00	6.00	5.00	25.30	20.0	20.0	130.00	20.0	2000.0	29.0	20.0	SR M6X16 DIN912	HW 5.0
HFHPR/L 25M	3.00	6.00	5.00	30.30	25.0	25.0	150.00	20.0	2000.0	34.0	25.0	SR M6X16 DIN912	HW 5.0

- DGN & GRIP 4.. - 6.. inserts can be used only with right-hand tools, HGPL 4.. - 6.. inserts with left-hand tools
- After initial groove, no limitation to widening groove outward or toward center
- For user guide, see pages 572-584

⁽¹⁾ Minimum cutting width
⁽²⁾ Maximum cutting width
⁽³⁾ Minimum penetration diameter
⁽⁴⁾ Maximum penetration diameter

Boring Bars for Adapters

HGAIR/L & HFAIR/L Adapters and HAI Holders

Adapter clamped on **HAI** round shank holders can machine deep internal boring and grooving applications. The tool can bore down to the bottom, and is supplied with internal coolant for better performance.



HFAIR/L & HGAIR/L

Exchangeable adapters, see pages 554-555

HAI Holders

for adapters, see page 554

HFAIR/L HGAIR/L	- □	C	- □	T - □
HELIFACE Internal adapters right or left	Min. initial groove diameter	Internal coolant	Insert width	Max. depth of groove



HAI Holder System Assembly

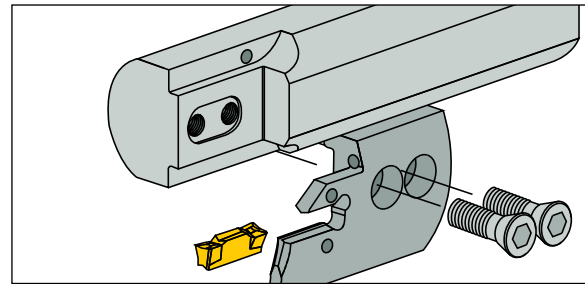
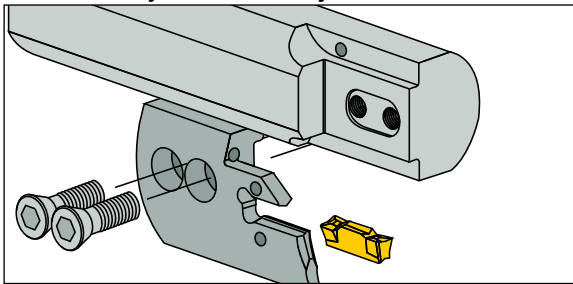

HFAIR & HGAIR
Left-hand Adapters

The same **HAI** boring bar can be used with right- and left-hand adapters in a wide range of face machining applications. The two screws and the central guiding

HFAIR & HGAIR
Right-hand Adapters

slot on the adapter correspond to the key and holes on the holder ensuring strong, safe, and accurate clamping.

Coolant System

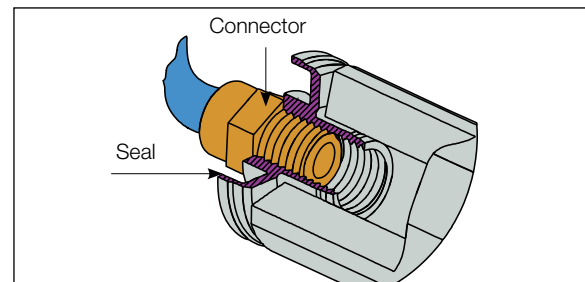
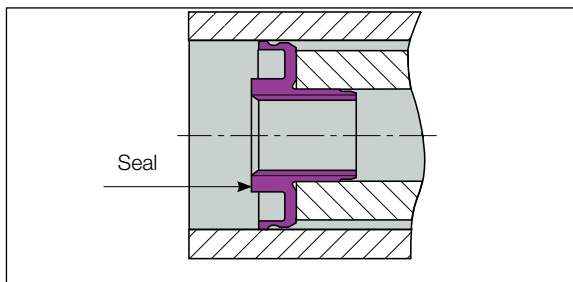
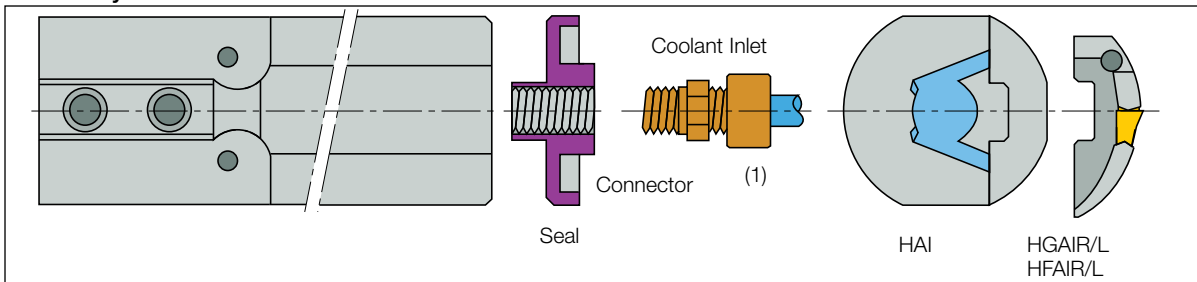

(1) Connector for coolant inlet BSP 1/8 thread. For PL-20, use M6 thread. Connector not supplied with tools.

HELIFACE

HGAIR/L-3

Adapters for Internal Face Grooving and Turning

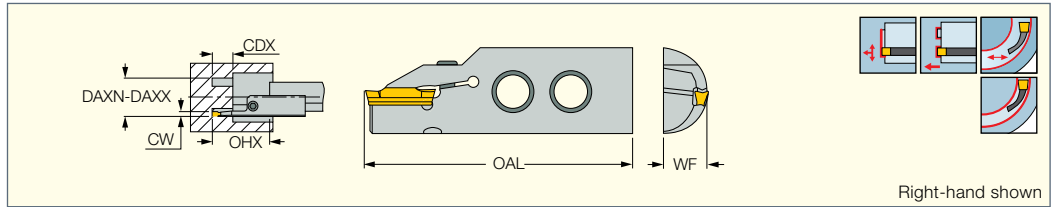

Right-hand shown

Designation	CDX	DAXN ⁽¹⁾	DAXX ⁽²⁾	CW	OAL	WF	OHX ⁽³⁾		
HGAIR/L 12-3M	2.00	12.0	500.0	3.00	55.00	10.2	21.0	SR 16-236 P	T-15/3
HGAIR/L 12-3T6	6.00	12.0	15.0	3.00	55.00	10.2	21.0	SR 16-236 P	T-15/3
HGAIR/L 14-3T7	7.00	14.0	17.0	3.00	55.00	10.2	21.0	SR 16-236 P	T-15/3
HGAIR/L 17-3T8	8.00	17.0	21.0	3.00	55.00	10.2	21.0	SR 16-236 P	T-15/3
HGAIR/L 21-3T9	9.00	21.0	25.0	3.00	55.00	10.2	21.0	SR 16-236 P	T-15/3
HGAIR/L 25-3T9	9.00	25.0	34.0	3.00	55.00	10.2	21.0	SR 16-236 P	T-15/3
HGAIR/L 35-3T10	10.00	35.0	45.0	3.00	56.00	10.3	22.0	SR 16-236 P	T-15/3
HGAIR/L 45-3T10	10.00	45.0	65.0	3.00	56.00	10.3	22.0	SR 16-236 P	T-15/3
HGAIR/L 115-3T18	18.00	115.0	400.0	3.00	64.00	11.3	30.0	SR 16-236 P	T-15/3
HGAIR/L 65-3T18	18.00	65.0	115.0	3.00	64.00	11.3	30.0	SR 16-236 P	T-15/3

• HGN & GRIP 3.. inserts can be used only with right-hand adapters, HGPL 3.. inserts with left-hand adapters • For user guide, see pages 572-584

⁽¹⁾ Minimum penetration diameter

⁽²⁾ Maximum penetration diameter

⁽³⁾ Maximum overhang

For inserts, see pages: GRIP (254) • GRIP (full radius) (255) • HGN-C (445) • HGN-J (446) • HGN-UT (446) • HGPL (560)

For holders, see pages: C#-HAD (595) • C#-HAPR/L (595) • HAI-C (554) • HAPR/L (551) • HAR/L (551) • IM-HAD (600) • IM-HAPR/L (600)

HELIFACE

HFAIR/L-4

Adapters for Internal Face Grooving and Turning

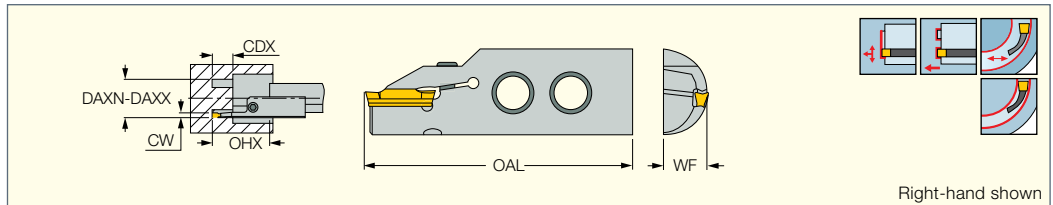

Right-hand shown

Designation	CDX	CW	DAXN ⁽¹⁾	DAXX ⁽²⁾	OAL	WF	OHX ⁽³⁾		
HFAIR/L 34-4T18	18.00	4.00	34.0	40.0	67.00	15.3	33.0	SR M5X16 DIN912	HW 4.0
HFAIR/L 40-4T20	20.00	4.00	40.0	48.0	67.00	15.3	33.0	SR M5X16 DIN912	HW 4.0
HFAIR/L 48-4T20	20.00	4.00	48.0	60.0	67.00	15.3	33.0	SR M5X16 DIN912	HW 4.0
HFAIR/L 60-4T25	25.00	4.00	60.0	75.0	67.00	15.3	33.0	SR M5X16 DIN912	HW 4.0

• DGN & GRIP inserts can be used only with right-hand adapters, HGPL inserts with left-hand blades • For user guide, see pages 572-584

⁽¹⁾ Minimum penetration diameter

⁽²⁾ Maximum penetration diameter

⁽³⁾ Maximum overhang

For inserts, see pages: DGN-MF (442) • HFPR/L (558) • HFPR/L (full radius) (558) • GRIP (254) • GRIP (full radius) (255) • DGN/DGNC/DGNM-C (438) • DGN/DGNM-J/JS/JT (440) • HGPL (560)

For holders, see pages: C#-HAD (595) • C#-HAPR/L (595) • HAI-C (554) • HAPR/L (551) • HAR/L (551) • IM-HAD (600) • IM-HAPR/L (600)

HELIFACE

HAI-C

Boring Bars with Coolant Holes for Internal Grooving and Turning Adapters

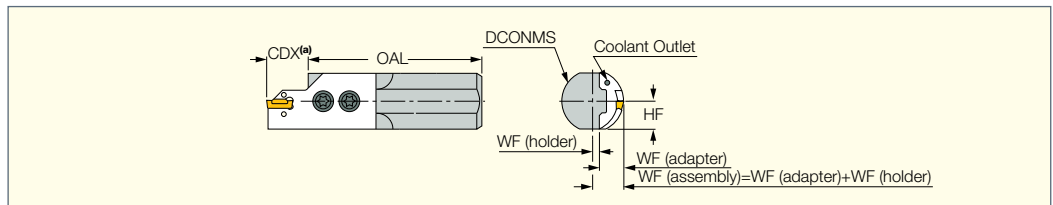

Designation	DCONMS	OAL	HF	WF ⁽¹⁾	CSP ⁽²⁾			
HAI 20	20.00	130.00	9.0	0.50	0	SR 14-519	T-20/3	
HAI 25C	25.00	150.00	11.5	3.00	1	SR 14-519	T-20/3	PL 25
HAI 32C	32.00	200.00	14.5	6.50	1	SR 14-519	T-20/3	PL 32
HAI 40C	40.00	250.00	18.0	10.50	1	SR 14-519	T-20/3	PL 40

• The HAI boring bars can be used with right and left-hand adapters • (a) CDX - see corresponding adapters

⁽¹⁾ Holder

⁽²⁾ 0 - Without coolant supply, 1 - With coolant supply

For tools, see pages: HFAIR/L-4 (554) • HFAIR/L-DG (555) • HGAIR/L-3 (554)

HFAIR/L-DG
Adapters for Internal Face Grooving and Turning

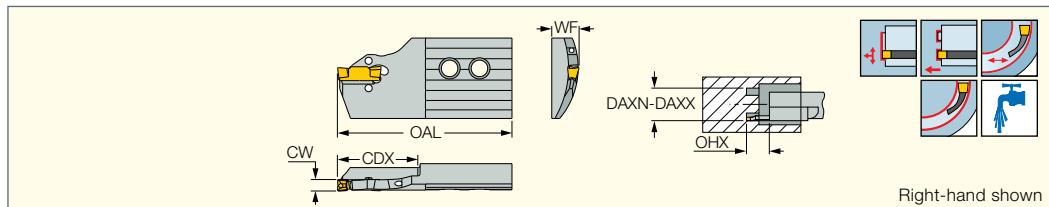

Designation	CW	DAXN ⁽¹⁾	DAXX ⁽²⁾	CDX	WF	OHX ⁽³⁾	OAL	
HFAIR/L 140C-4T30DG	4.00	140.0	-	30.00	10.9	34.5	68.50	EDG 33B*
HFAIR/L 75C-4T30DG	4.00	75.0	140.0	30.00	10.9	34.5	68.50	EDG 33B*
HFAIR/L 130C-5T38DG	5.00	130.0	180.0	38.00	11.9	42.5	76.50	EDG 33B*
HFAIR/L 180C-5T38DG	5.00	180.0	-	38.00	11.9	42.5	76.50	EDG 33B*
HFAIR/L 55C-5T25DG	5.00	55.0	70.0	25.00	11.9	32.0	66.00	EDG 33B*
HFAIR/L 70C-5T25DG	5.00	70.0	95.0	25.00	11.9	32.0	66.00	EDG 33B*
HFAIR/L 95C-5T35DG	5.00	95.0	130.0	35.00	11.9	39.5	73.50	EDG 33B*
HFAIR/L 100C-6T32DG	6.00	100.0	180.0	32.00	12.0	39.0	73.00	EDG 33B*
HFAIR/L 180C-6T38DG	6.00	180.0	-	38.00	12.4	42.5	76.50	EDG 33B*
HFAIR/L 70C-6T28DG	6.00	70.0	100.0	28.00	12.0	35.0	69.00	EDG 33B*

• After initial groove, no limitation to widening groove outward or toward center • DGN inserts can be used on right- and left-hand tools, GRIP inserts only on right-hand tools, HFPR/L right-hand inserts on right-hand tools (same for left-hand), and HGPL inserts only on left-hand tools.

- ⁽¹⁾ Minimum penetration diameter
- ⁽²⁾ Maximum penetration diameter
- ⁽³⁾ Maximum overhang

* Optional, should be ordered separately

For inserts, see pages: DGN-MF (442) • HFPR/L (558) • HFPR/L (full radius) (558) • GRIP (254) • GRIP (full radius) (255) • DGN/DGNC/DGNM-C (438) • DGN/DGNM-J/JS/JT (440) • DGN-W (439) • HGPL (560)

For holders, see pages: C#-HAD (595) • C#-HAPR/L (595) • HAI-C (554) • HAPR/L (551) • HAR/L (551) • IM-HAD (600) • IM-HAPR/L (600)

Adapters can be used for internal machining along bore. Adapters can be mounted on standard HAI boring bars for internal machining and on HAR/L, HAPR/L holders for external machining

Boring, Face Grooving & Face Recessing Capacity

Boring

B Min. =WF (assembly)+G+DCONMS/2

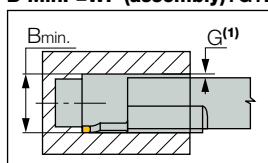

⁽¹⁾ The minimum recommended value for clearance (G) is 0.5 mm

* WF (assembly)=WF(adapter)+WF(holder)

Face Grooving

D Min. =2WF (assembly)-B+2G+DCONMS

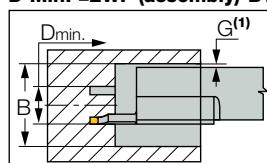

Face Recessing

P Min. =2WF (assembly)-B-2CW+2G+DCONMS

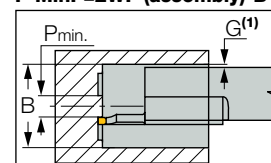

C#-HFIR/L-MC
Boring Bars for Internal Grooving and Turning with CAMFIX Exchangeable Shanks

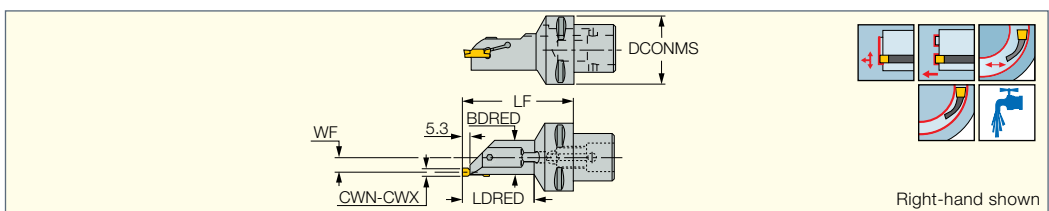

Designation	CWN ⁽¹⁾	CWX ⁽²⁾	DCONMS	WF	LDRED	LF	BDRED			
C4 HFIR/L-MC	3.00	6.00	40	11.30	52.0	80.0	25.00	SR M5X16 DIN912	HW 4.0	EZ 83
C5 HFIR/L-MC	3.00	6.00	50	11.30	52.0	80.0	25.00	SR M5X16 DIN912	HW 4.0	EZ 83

• DGN & GRIP 4.. - 6.. inserts can be used only with right-hand tools, HGPL 4.. - 6.. inserts with left-hand tools • After initial groove, no limitation to widening groove outward or toward center • For user guide, see pages 572-584

- ⁽¹⁾ Minimum cutting width
- ⁽²⁾ Maximum cutting width

For inserts, see pages: DGN-MF (442) • HFPR/L (558) • HFPR/L (full radius) (558) • GRIP (254) • GRIP (full radius) (255) • DGN/DGNC/DGNM-C (438) • DGN/DGNM-J/JS/JT (440) • DGN-W (439) • HGPL (560)

For holders, see pages: HSK-C# (676)

ISO 26622-1 XMZ

HELIFACE

IM-HFIR-MC

Tools for Internal Grooving and Turning with ISO 26622-1(*) Tapered Shank

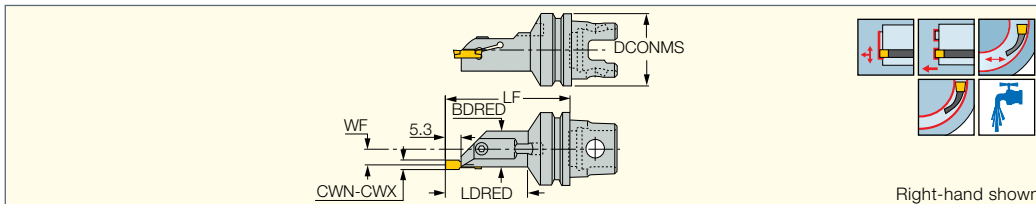

Designation	DCONMS	LF	BDRED	WF	LDRED	CWN ⁽¹⁾	CWX ⁽²⁾			
IM40 HFIR-MC	40	80.0	25.00	11.30	52.0	3.00	6.00	SR M5X16 DIN912	HW 4.0	EZ 83
IM50 HFIR-MC	50	80.0	25.00	11.30	52.0	3.00	6.00	SR M5X16 DIN912	HW 4.0	EZ 83

• (*) Tools with orientation holes in the flange groove can be supplied on request • DGN & GRIP 4.. - 6.. inserts can be used only with right-hand tools, HGPL 4.. - 6.. inserts with left-hand tools • After initial groove, no limitation to widening groove outward or toward center • For user guide, see pages 572-584

⁽¹⁾ Minimum cutting width

⁽²⁾ Maximum cutting width

For inserts, see pages: DGN-MF (442) • HFPR/L (558) • HFPR/L (full radius) (558) • GRIP (254) • GRIP (full radius) (255) • DGN/DGNC/DGNM-C (438) • DGN/DGNM-J/JS/JT (440) • DGN-W (439)

HELIFACE

HFIR/L-MC

Boring Bars for Internal Grooving and Turning

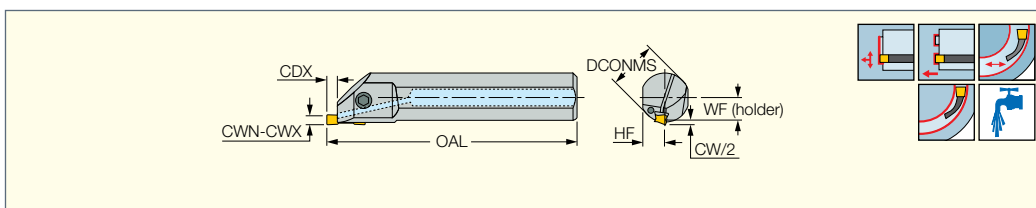

Designation	DCONMS	CWN ⁽¹⁾	CWX ⁽²⁾	CDX	OAL	WF	HF			
HFIR/L 16MC	16.00	3.00	6.00	5.00	150.00	11.14	7.5	SR M5X16 DIN912	HW 4.0	PL 16
HFIR/L 20MC	20.00	3.00	6.00	5.00	170.00	11.14	9.0	SR M5X16 DIN912	HW 4.0	PL 20
HFIR/L 25MC	25.00	3.00	6.00	5.00	200.00	11.14	11.5	SR M5X16 DIN912	HW 4.0	PL 25
HFIR/L 32MC	32.00	3.00	6.00	5.00	250.00	14.68	14.5	SR M6X20 DIN912	HW 5.0	PL 32
HFIR/L 40MC	40.00	3.00	6.00	5.00	300.00	18.70	18.0	SR M6X20 DIN912	HW 5.0	PL 40

• DGN & GRIP 4.. - 6.. inserts can be used only with right-hand tools, HGPL 4.. - 6.. inserts with left-hand tools • After initial groove, no limitation to widening groove outward or toward center • For user guide, see pages 572-584

⁽¹⁾ Minimum cutting width

⁽²⁾ Maximum cutting width

For inserts, see pages: DGN-MF (442) • HFPR/L (558) • HFPR/L (full radius) (558) • GRIP (254) • GRIP (full radius) (255) • DGN/DGNC/DGNM-C (438) • DGN/DGNM-J/JS/JT (440) • DGN-W (439) • HGPL (560)

Boring

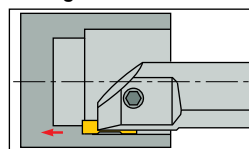

Internal Face Grooving

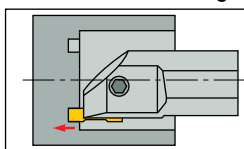

Internal Face Recessing

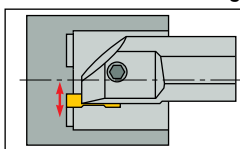

HFIR/L-: MC Integral Boring bars

For shallow, internal face machining to max. 5 mm depth of groove. One boring bar can be mounted with inserts in 4-6 mm widths.

The initial major diameter groove is limited by the insert's geometry in each size. After the initial groove, face recessing outward or toward center is not limited by the insert's geometry.

Boring, Face Grooving & Face Recessing Capacity

Boring

D Min. =WF(holder)+ DCONMS/2+CW/2+2G

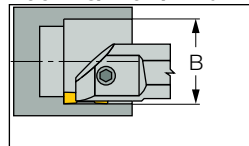

Face Grooving

D Min. =2WF (holder)+ DCONMS+CW-B+2G

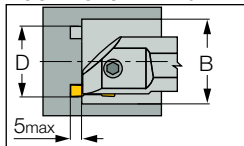

Face Recessing

P Min. =2WF (holder)+ DCONMS-W-B+2G

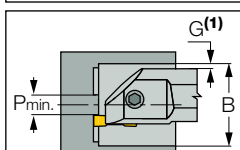
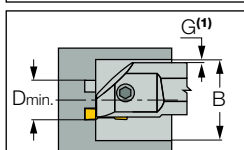
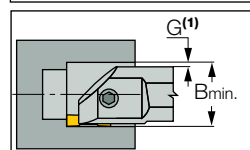
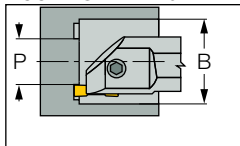

⁽¹⁾ The minimum recommended value for clearance (G) is 0.5 mm

Insert Initial Face Grooving Range

CW	D	
	Min.	Max.
4	23	90
5	21	300
6	20	∞

CR HFIR-M

Cartridges for Face Grooving and Turning

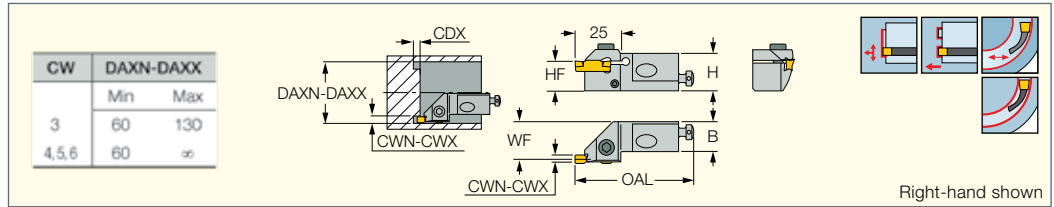

Designation	CWN ⁽¹⁾	CWX ⁽²⁾	HF	B	H	OAL	WF	CDX
CR HFIR-16M	3.00	6.00	16.0	16.0	20.0	67.00	20.00	5.00
CR HFIR-20M	3.00	6.00	20.0	20.0	24.0	72.00	24.00	5.00

• Used for shallow internal face machining to max. 5 mm depth of groove • Inserts in 3-6 mm widths can be mounted on the cartridges • Only DGN & GRIP 4.. - 6.. inserts can be used with the right-hand tools

⁽¹⁾ Minimum cutting width

⁽²⁾ Maximum cutting width

For inserts, see pages: DGN-MF (442) • HFPR/L (558) • HFPR/L (full radius) (558) • GRIP (254) • GRIP (full radius) (255) • DGN/DGNC/DGNM-C (438) • DGN/DGNM-J/JS/JT (440) • DGN-W (439)

CR-HFIR/L-M

Assembly Dimensions



Designation	E	L ₁ ⁽¹⁾	F ⁽²⁾	R _{max.}	Assembly Screw ⁽³⁾
CR HFIR/L-16M	25	8	20	6	M8X30
CR HFIR/L-20M	30	10	24	6	M8X30

⁽¹⁾ L adjustment ± 1

⁽²⁾ F adjustment +0.3

- 0

⁽³⁾ Assembly screws ISO 7380 are recommended

Spare Parts

Designation					
CR HFIR-16M	SR M5X20DIN912	HW 4.0	SR 76-1401	SR M4X10 DIN916	HW 2.0
CR HFIR-20M	SR M5X20DIN912	HW 4.0	SR 76-1401	SR M4X10 DIN913	HW 2.0

HFPN

Utility Double-Ended Face Machining Inserts

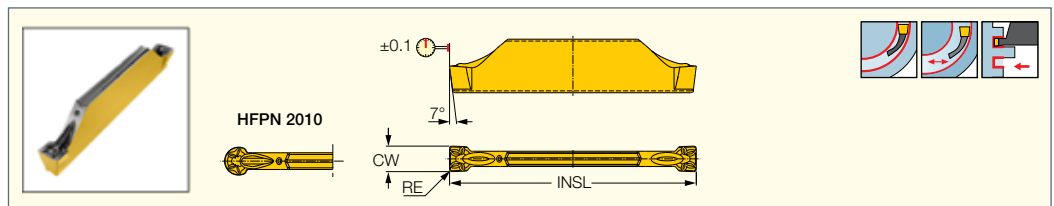

Designation	Dimensions					IC808	Recommended Machining Data
	CW	RE	CWTOL ⁽¹⁾	RETOL ⁽²⁾	INSL		f groove (mm/rev)
HFPN 2002	2.00	0.20	0.04	0.030	19.40	•	0.03-0.10
HFPN 2010	2.00	1.00	0.04	0.030	19.40	•	0.03-0.10

• For cutting speed recommendations and user guide, see pages 572-584

⁽¹⁾ Cutting width tolerance (+/-)

⁽²⁾ Corner radius tolerance (+/-)

For tools, see pages: HFFA (546) • HFFH (546)

HELIFACE

HFPR/L
Utility Double-Ended Face
Machining Inserts

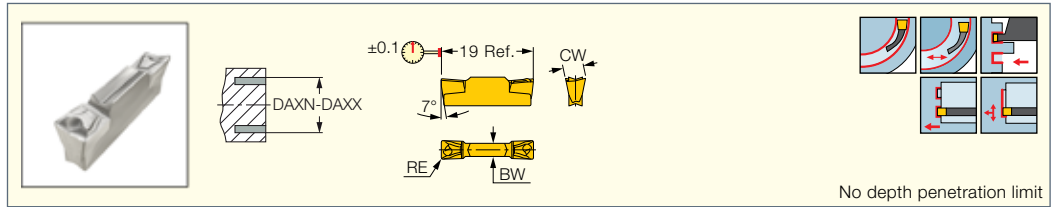

Designation	Dimensions							Tough ↔ Hard						Recommended Machining Data				
	CW	RE	CWTOL ⁽¹⁾	RETOL ⁽²⁾	BW	DAXN ⁽³⁾	DAXX ⁽⁴⁾	IC830	IC354	IC8250	IC808	IC9015	IC20	IC5010	IC806	a _p (mm)	f face-groove (mm/rev)	f face-turn (mm/rev)
								●	●	●	●	●	●	●	●			
HFPR/L 3003	3.00	0.30	0.05	0.050	2.10	25.6	51.5	●	●	●	●	●	●	●	●	0.30-1.50	0.08-0.20	0.10-0.20
HFPR/L 4004	4.00	0.40	0.05	0.050	2.80	24.1	73.7	●	●	●	●	●	●	●	●	0.40-2.00	0.10-0.24	0.15-0.25
HFPR/L 5004	5.00	0.40	0.05	0.050	3.40	22.1	170.0	●	●	●	●	●	●	●	●	0.50-2.50	0.12-0.24	0.15-0.35
HFPR/L 6004	6.00	0.40	0.05	0.050	4.00	20.8	-	●	●	●	●	●	●	●	●	0.40-3.00	0.12-0.28	0.15-0.40

• For cutting speed recommendations and user guide, see pages 572-584

⁽¹⁾ Cutting width tolerance (+/-)

⁽²⁾ Corner radius tolerance (+/-)

⁽³⁾ Minimum axial grooving diameter-applies to type M tools only. For other tools, apply the diameter limitations that are recorded on each tool.

⁽⁴⁾ Maximum axial grooving diameter-applies to type M tools only. For other tools, apply the diameter limitations that are recorded on each tool.

For tools, see pages: C#-HFIR/L-MC (555) • CR HFIR-M (557) • HFAER/L-4 (551) • HFAER/L-5T, 6T (552) • HFAIR/L-4 (554) • HFAIR/L-DG (555) • HFFR/L-T (550) • HFHPR/L-M (552) • HFHR/L-3T (547) • HFHR/L-4T (548) • HFHR/L-5T (548) • HFHR/L-6T (549) • HFHR/L-M (552) • HFIR/L-MC (556) • HFPAD-4 (549) • HFPAD-5 (550) • HFPAD-6 (550) • IM-HFIR-MC (556)

HELIFACE

HFPR/L (full radius)
Utility Double-Ended Full Radius
Face Machining Inserts

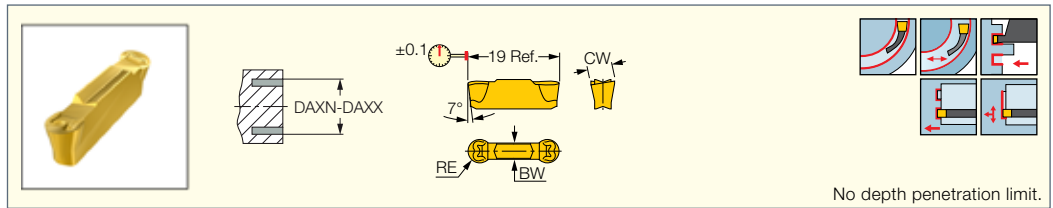

Designation	Dimensions							Tough ↔ Hard						Recommended Machining Data				
	CW	RE	CWTOL ⁽¹⁾	RETOL ⁽²⁾	BW	DAXN ⁽³⁾	DAXX ⁽⁴⁾	IC830	IC354	IC8250	IC808	IC9015	IC20	IC5010	IC806	a _p (mm)	f face-groove (mm/rev)	f face-turn (mm/rev)
								●	●	●	●	●	●	●	●			
HFPR/L 3015	3.00	1.50	0.05	0.050	2.10	25.6	51.5	●	●	●	●	●	●	●	●	0.00-1.50	0.08-0.20	0.12-0.20
HFPR/L 4020	4.00	2.00	0.05	0.050	2.80	24.1	73.7	●	●	●	●	●	●	●	●	0.00-2.00	0.10-0.24	0.15-0.25
HFPR/L 5025	5.00	2.50	0.05	0.050	3.40	22.1	170.0	●	●	●	●	●	●	●	●	0.00-2.50	0.12-0.24	0.15-0.35
HFPR/L 6030	6.00	3.00	0.05	0.050	4.00	20.8	-	●	●	●	●	●	●	●	●	0.00-3.00	0.12-0.28	0.20-0.40

• For cutting speed recommendations and user guide, see pages 572-584

⁽¹⁾ Cutting width tolerance (+/-)

⁽²⁾ Corner radius tolerance (+/-)

⁽³⁾ Minimum axial grooving diameter-applies to type M tools only. For other tools, apply the diameter limitations that are recorded on each tool.

⁽⁴⁾ Maximum axial grooving diameter-applies to type M tools only. For other tools, apply the diameter limitations that are recorded on each tool.

For tools, see pages: C#-HFIR/L-MC (555) • CR HFIR-M (557) • HFAER/L-4 (551) • HFAER/L-5T, 6T (552) • HFAIR/L-4 (554) • HFAIR/L-DG (555) • HFFR/L-T (550) • HFHPR/L-M (552) • HFHR/L-3T (547) • HFHR/L-4T (548) • HFHR/L-5T (548) • HFHR/L-6T (549) • HFHR/L-M (552) • HFIR/L-MC (556) • HFPAD-4 (549) • HFPAD-5 (550) • HFPAD-6 (550) • IM-HFIR-MC (556)

GRIP

Utility Double-Ended Inserts for External, Internal and Face Machining

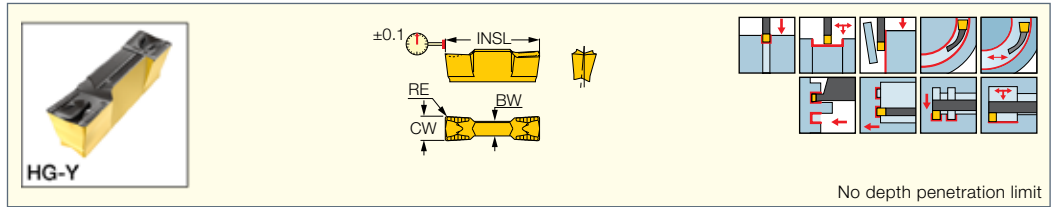

Designation	Dimensions						Tough ↔ Hard								Recommended Machining Data						
	CW	RE	CWTOL ⁽¹⁾	RETOL ⁽²⁾	INSL	BW	IC830	IC8250	IC08	IC808	IC908	IC418	IC5010	IC806	IC807	IC804	a _p (mm)	f turn (mm/rev)	f groove (mm/rev)	f face-groove (mm/rev)	f face-turn (mm/rev)
GRIP 3002Y	3.00	0.20	0.05	0.050	16.00	2.30	●	●	●	●	●	●	●	●	●	●	0.25-1.80	0.14-0.18	0.07-0.11	0.08-0.20	0.10-0.20
GRIP 3003Y	3.00	0.30	0.05	0.050	16.00	2.30	●	●	●	●	●	●	●	●	●	●	0.40-1.80	0.15-0.19	0.07-0.11	0.08-0.20	0.10-0.20
GRIP 318-040Y	3.18	0.40	0.05	0.050	16.00	2.30	●	●	●	●	●	●	●	●	●	●	0.50-1.90	0.17-0.22	0.07-0.12	0.08-0.20	0.10-0.20
GRIP 4002Y	4.00	0.20	0.05	0.050	19.00	2.80	●	●	●	●	●	●	●	●	●	●	0.25-2.40	0.16-0.21	0.09-0.14	0.10-0.24	0.15-0.30
GRIP 4004Y	4.00	0.40	0.05	0.050	19.00	2.80	●	●	●	●	●	●	●	●	●	●	0.50-2.40	0.18-0.24	0.09-0.15	0.10-0.24	0.15-0.30
GRIP 476-080Y	4.76	0.80	0.05	0.050	19.00	3.10	●	●	●	●	●	●	●	●	●	●	1.00-2.80	0.21-0.33	0.10-0.20	0.10-0.24	0.15-0.30
GRIP 5005Y	5.00	0.50	0.05	0.050	19.00	3.30	●	●	●	●	●	●	●	●	●	●	0.60-3.00	0.20-0.30	0.11-0.20	0.12-0.24	0.15-0.35
GRIP 5008Y	5.00	0.80	0.05	0.050	19.00	3.40	●	●	●	●	●	●	●	●	●	●	1.00-3.00	0.23-0.35	0.11-0.21	0.12-0.24	0.15-0.35
GRIP 6005Y	6.00	0.50	0.05	0.050	19.00	4.20	●	●	●	●	●	●	●	●	●	●	0.60-3.60	0.22-0.36	0.13-0.23	0.12-0.28	0.15-0.40
GRIP 6008Y	6.00	0.80	0.05	0.050	19.00	4.20	●	●	●	●	●	●	●	●	●	●	1.00-3.60	0.24-0.42	0.13-0.25	0.12-0.28	0.15-0.40
GRIP 635-080Y	6.35	0.80	0.05	0.050	19.00	4.20	●	●	●	●	●	●	●	●	●	●	1.00-3.80	0.25-0.44	0.14-0.27	0.12-0.28	0.15-0.40

• For cutting speed recommendations and user guide, see pages 572-584

⁽¹⁾ Cutting width tolerance (+/-)

⁽²⁾ Corner radius tolerance (+/-)

For tools, see pages: C#-HELIR/L (249) • C#-HFIR/L-MC (555) • CR HFIR-M (557) • D/HGAD RE/LE-JHP (437) • DGAD/HGAD (436) • DGFH (252) • DGFH-JHP (253) • DGFS (427) • DGTR/L (433) • HELIIR/L (339) • HELIR/L (250) • HFAER/L-4 (551) • HFAER/L-5T, 6T (552) • HFAIR/L-4 (554) • HFAIR/L-DG (555) • HFFR/L-T (550) • HFHR/L-4T (548) • HFHR/L-5T (548) • HFIR/L-MC (556) • HFPAD-3 (549) • HFPAD-4 (549) • HFPAD-5 (550) • HFPAD-6 (550) • HGAER/L-3 (551) • HGAIIR/L-3 (554) • HGHR/L-3 (547) • HGPAD (251) • HGPAD-JHP (251) • IM-HFIR-MC (556)

The Twisted Insert
for Face Machining

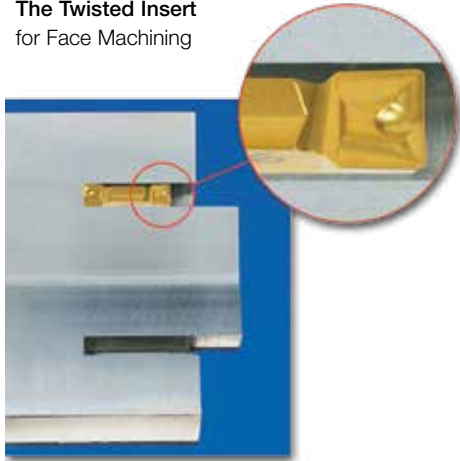

The double-ended, twisted insert body makes it possible to machine deeper than the inserts' length. A unique chipformer for controlled chip flow in axial and radial directions. The rear angle is slanted in relation to the frontal edge so it does not come into contact with the machined groove surface as the tool penetrates deeply into the workpiece.



HELIGRIP

GRIP (full radius)
Utility Double-Ended Full Radius Inserts for External, Internal and Face Machining

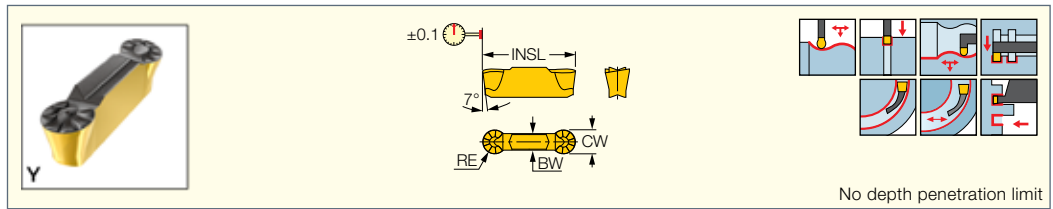

Designation	Dimensions						Tough ↔ Hard								Recommended Machining Data						
	CW	RE	CWTOL ⁽¹⁾	RETOL ⁽²⁾	INSL	BW	IC830	IC8250	IC08	IC808	IC908	IC418	IC5010	IC806	IC807	IC804	a _p (mm)	f turn (mm/rev)	f groove (mm/rev)	f face-groove (mm/rev)	f face-turn (mm/rev)
GRIP 3015Y	3.00	1.50	0.05	0.050	15.80	2.10	●	●	●	●	●	●	●	●	●	●	0.00-1.50	0.18-0.26	0.07-0.13	0.08-0.20	0.10-0.20
GRIP 318-159Y	3.18	1.59	0.05	0.050	16.00	2.30				●	●						0.00-1.50	0.19-0.28	0.07-0.13	0.08-0.20	0.10-0.20
GRIP 4020Y	4.00	2.00	0.05	0.050	19.00	2.80	●	●	●	●	●	●	●	●	●	●	0.00-2.00	0.20-0.34	0.09-0.17	0.10-0.24	0.15-0.30
GRIP 476-238Y	4.76	2.38	0.05	0.050	19.00	3.20				●	●						0.00-2.30	0.21-0.40	0.10-0.20	0.10-0.24	0.15-0.30
GRIP 5025Y	5.00	2.50	0.05	0.050	19.00	3.40	●	●	●	●	●	●	●	●	●	●	0.00-2.50	0.23-0.42	0.11-0.21	0.12-0.24	0.15-0.35
GRIP 6030Y	6.00	3.00	0.05	0.050	19.00	4.20	●	●	●	●	●	●	●	●	●	●	0.00-3.00	0.24-0.50	0.13-0.25	0.12-0.28	0.15-0.40
GRIP 635-318Y	6.35	3.18	0.05	0.050	19.00	4.00				●	●						0.00-3.10	0.25-0.53	0.14-0.27	0.12-0.28	0.15-0.40

• For cutting speed recommendations and user guide, see pages 572-584

⁽¹⁾ Cutting width tolerance (+/-)

⁽²⁾ Corner radius tolerance (+/-)

For tools, see pages: C#-HELIR/L (249) • C#-HFIR/L-MC (555) • CR HFIR-M (557) • D/HGAD RE/LE-JHP (437) • DGAD/HGAD (436) • DGFH (252) • DGFH-JHP (253) • DGFS (427) • DGTR/L (433) • HELIIR/L (339) • HELIR/L (250) • HFAER/L-4 (551) • HFAER/L-5T, 6T (552) • HFAIR/L-4 (554) • HFAIR/L-DG (555) • HFFR/L-T (550) • HFHR/L-4T (548) • HFHR/L-5T (548) • HFHR/L-6T (549) • HFIR/L-MC (556) • HFPAD-3 (549) • HFPAD-4 (549) • HFPAD-5 (550) • HFPAD-6 (550) • HGAER/L-3 (551) • HGAIIR/L-3 (554) • HGFH (251) • HGHR/L-3 (547) • HGPAD (251) • HGPAD-JHP (251) • IM-HFIR-MC (556)

HELIFACE

HGPL
Utility Double-Ended Inserts for Face Machining

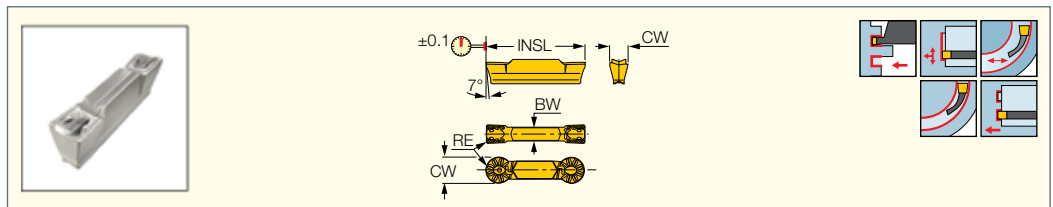

Designation	Dimensions						Tough ↔ Hard						Recommended Machining Data		
	CW	BW	RE	CWTOL ⁽¹⁾	RETOL ⁽²⁾	INSL	IC328	IC354	IC08	IC808	IC908	IC806	a _p (mm)	f face-groove (mm/rev)	f face-turn (mm/rev)
HGPL 3002Y	3.00	2.30	0.20	0.03	0.050	16.00		●	●	●	●		0.24-1.80	0.08-0.20	0.12-0.23
HGPL 3003Y	3.00	2.30	0.30	0.03	0.050	16.00	●	●	●	●			0.36-1.80	0.08-0.20	0.12-0.23
HGPL 3015Y	3.00	2.10	1.50	0.03	0.050	16.00				●	●		0.00-1.50	0.08-0.20	0.12-0.23
HGPL 4002Y	4.00	2.80	0.20	0.03	0.050	19.00		●	●	●	●		0.24-2.40	0.10-0.24	0.16-0.30
HGPL 4004Y	4.00	2.80	0.40	0.03	0.050	19.00		●	●	●	●		0.48-2.40	0.10-0.24	0.16-0.30
HGPL 4020Y	4.00	2.80	2.00	0.03	0.050	19.00			●	●	●		0.00-2.00	0.10-0.24	0.16-0.30
HGPL 5005Y	5.00	3.30	0.50	0.03	0.050	19.00		●	●	●	●		0.60-3.00	0.12-0.24	0.20-0.38
HGPL 5025Y	5.00	3.30	2.50	0.03	0.050	19.00			●	●	●		0.00-2.50	0.12-0.24	0.20-0.38
HGPL 6005Y	6.00	4.20	0.50	0.03	0.050	19.00		●	●	●	●		0.60-3.60	0.12-0.28	0.24-0.45
HGPL 6030Y	6.00	4.20	3.00	0.03	0.050	19.00			●	●	●	●	0.00-3.00	0.12-0.28	0.24-0.45

• No depth penetration limit • For cutting speed recommendations and user guide, see pages 572-584

⁽¹⁾ Cutting width tolerance (+/-)

⁽²⁾ Corner radius tolerance (+/-)

For tools, see pages: C#-HFIR/L-MC (555) • HFAER/L-4 (551) • HFAER/L-5T, 6T (552) • HFAIR/L-4 (554) • HFAIR/L-DG (555) • HFFR/L-T (550) • HFHR/L-4T (548) • HFHR/L-5T (548) • HFHR/L-6T (549) • HFIR/L-MC (556) • HFPAD-3 (549) • HFPAD-4 (549) • HFPAD-5 (550) • HFPAD-6 (550) • HGAER/L-3 (551) • HGAIIR/L-3 (554) • HGHR/L-3 (547)

CUTGRIP

GHFG-R/L-8

Holders for Face Grooving and Turning Along Shafts

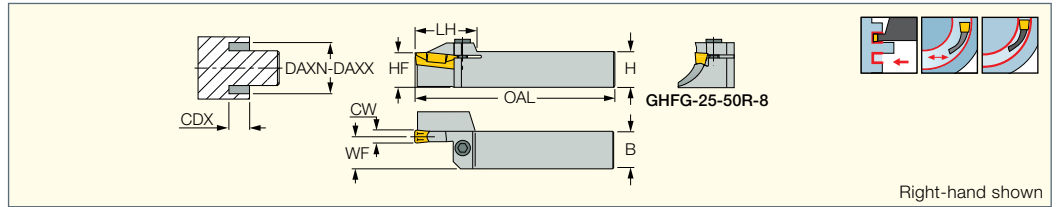

Right-hand shown

Designation	CDX	DAXN ⁽¹⁾	DAXX ⁽²⁾	H	HF	B	OAL	LH	WF		
GHFG 25-50R/L-8	25.00	50.0	64.0	25.0	25.0	25.0	150.00	41.0	22.00	SR M6X20 DIN912	HW 5.0
GHFG 25-63R/L-8	25.00	63.0	82.0	25.0	25.0	25.0	150.00	41.0	22.00	SR M6X20 DIN912	HW 5.0
GHFG 32-63R-8	25.00	63.0	82.0	32.0	32.0	32.0	170.00	41.0	30.00	SR M6X20 DIN912	HW 5.0

• For user guide, see pages 572-584

⁽¹⁾ Minimum penetration diameter

⁽²⁾ Maximum penetration diameter

CUTGRIP

GHFGR/L-8

Holders for Face Grooving and Turning

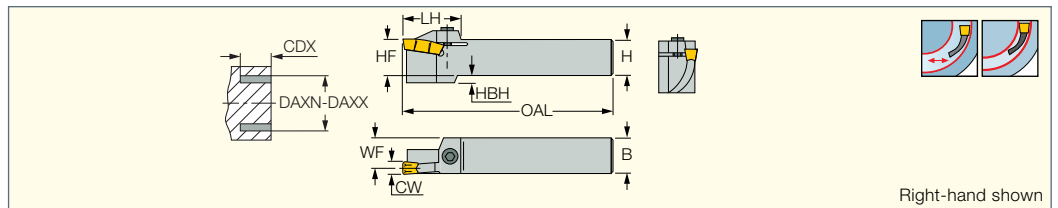

Right-hand shown

Designation	DAXN ⁽¹⁾	DAXX ⁽²⁾	H	HF	B	OAL	LH	WF	HBH		
GHFGR/L 25-80-8	80.0	115.0	25.0	25.0	25.0	150.00	43.5	21.30	6.0	SR M6X20 DIN912	HW 5.0
GHFGR/L 32-80-8	80.0	115.0	32.0	32.0	32.0	170.00	43.5	28.30	-	SR M6X20 DIN912	HW 5.0
GHFGR/L 25-105-8	105.0	160.0	25.0	25.0	25.0	150.00	43.5	21.30	6.0	SR M6X20 DIN912	HW 5.0
GHFGR/L 25-155-8	155.0	510.0	25.0	25.0	25.0	150.00	43.5	21.30	6.0	SR M6X20 DIN912	HW 5.0
GHFGR/L 32-105-8	105.0	160.0	32.0	32.0	32.0	170.00	43.5	28.30	-	SR M6X20 DIN912	HW 5.0
GHFGR/L 32-155-8	155.0	510.0	32.0	32.0	32.0	170.00	43.5	28.30	-	SR M6X20 DIN912	HW 5.0

• No limitation to widening the groove either way after initial grooving • Tmax depends on the penetration diameter and the insert • For user guide, see pages 572-584

⁽¹⁾ Minimum penetration diameter

⁽²⁾ Maximum penetration diameter

CDX for GHFGR/L (25/32)-80-8							
D	GIF 8...	GIFG 8...	GDMY 8...	GIPA 8...	GIDA 8...	GIA 8...	GDMM 8CC...
80	16	23	23	20	24	16	24
82	17	23	23	20	24	17	24
84	18	23	23	21	24	18	24
86	19	23	23	21	24	19	24
88	20	23	23	22	24	20	24
90	20	23	23	22	24	20	24
96	20	23	23	22	24	20	24
104	20	23	23	22	24	20	24
115	22	23	23	22	24	22	24

CDX for GHFGR/L (25/32)-105-8							
D	GIF 8...	GIFG 8...	GDMY 8...	GIPA 8...	GIDA 8...	GIA 8...	GDMM 8CC...
105	21	23	23	23	24	21	24
114	22	23	23	23	24	22	24
126	23	23	24	23	24	23	24
140-160	24	24	24	23	24	24	24

CDX for GHFGR/L (25/32)-155-8							
D	GIF 8...	GIFG 8...	GDMY 8...	GIPA 8...	GIDA 8...	GIA 8...	GDMM 8CC...
155	24	24	24	23	24	24	24
180	24	24	24	23	24	24	24
210-510	24	24	24	23	24	24	24

CUTGRIP

GHAR/L-8

External Holders for Grooving and Turning Adapters

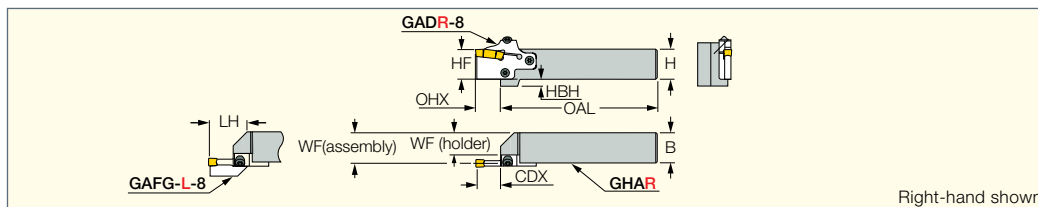

Designation	H	HF	B	WF ⁽¹⁾	OAL	LH	OHX ⁽²⁾	HBH	TGA ⁽³⁾	CDX ⁽⁴⁾	FG ⁽⁵⁾				
GHAR/L 25-8	25.0	25.0	25.0	16.0	124.50	45.0	25.50	14.0	GADR/L 8	25.50	GAFG...R/L-8	SR 14-519	T-20/5	SR M6X25 DIN912	HW 5.0
GHAR/L 32-8	32.0	32.0	32.0	23.0	144.50	45.0	25.50	7.0	GADR/L 8	25.50	GAFG...R/L-8	SR 14-519	T-20/5	SR M6X25 DIN912	HW 5.0

• Adapters GADR/L-8 for turning and grooving, GAFG-R/L-8 for face-grooving (to be ordered separately)

⁽¹⁾ WF(holder)

⁽²⁾ Maximum overhang

⁽³⁾ Adapter for Turning & Grooving

⁽⁴⁾ See specific adapter dimensions

⁽⁵⁾ Adapter for Face Grooving

For tools, see pages: GADR/L-8 (269) • GAFG-R/L-8 (562) • PCADR/L 34N-RE (301)

CUTGRIP

GHAPR/L-8

External Holders for Grooving and Turning Perpendicularly Oriented Adapters

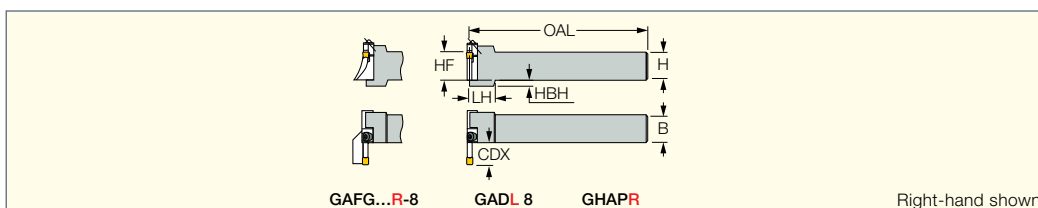

Designation	H	HF	B	OAL	LH	HBH	TGA ⁽¹⁾	CDX ⁽²⁾	FG ⁽³⁾				
GHAPR/L 32-8	32.0	32.0	32.0	155.00	30.0	7.0	GADR/L 8	25.50	GAFG...R/L-8	SR 14-519	T-20/5	SR M6X25 DIN912	HW 5.0

• Adapters GADR/L-8 for turning and grooving, GAFG-R/L-8 for face-grooving (to be ordered separately)

⁽¹⁾ Adapter for Turning & Grooving

⁽²⁾ See specific adapter dimensions

⁽³⁾ Adapter for Face Grooving

CUTGRIP

GAFG-R/L-8

Adapters for Face Machining

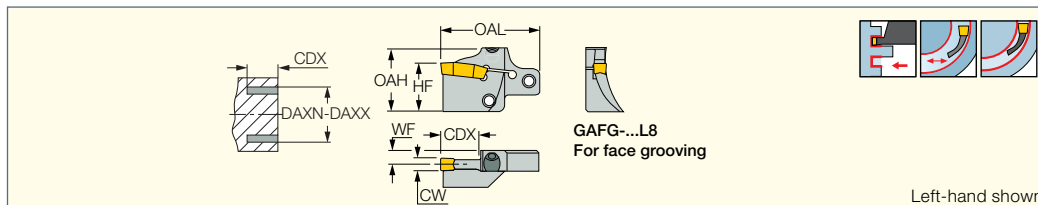

Designation	CW	DAXN ⁽¹⁾	DAXX ⁽²⁾	CDX ⁽³⁾	WF	HF	OAH	OAL
GAFG 105R/L-8	8.00	105.0	160.0	25.00	9.00	32.0	42.0	63.50
GAFG 155R/L-8	8.00	155.0	510.0	25.00	9.00	32.0	42.0	63.50
GAFG 80R/L-8	8.00	80.0	115.0	23.00	9.00	32.0	42.0	63.50

• No limitation for widening the groove either way after initial grooving • For user guide, see pages 572-584

⁽¹⁾ Minimum penetration diameter

⁽²⁾ Maximum penetration diameter

⁽³⁾ For GIFG-8 & GDMY-8 CDX=25 mm for DAX range

For inserts, see pages: GDMA (284) • GDMF (271) • GDMM-CC (565) • GDMN (273) • GDMU (273) • GDMY (272) • GDMY (full radius) (274) • GDMY-F (275) • GIA-K (long pocket) (282) • GIF (long pocket) (281) • GIF-E (W=8,10 full radius) (277) • GIF-E (W=8,10) (276) • GIFG-E (W=8) (563) • GIPA/GIDA 8 (full radius) (286)

For holders, see pages: C#-GHAD-8 (594) • C#-GHAPR/L-8 (594) • GHAPR/L-8 (269) • GHAR/L-8 (269) • IM-GHAD-8 (599) • IM-GHAPR/L-8 (600)

CUTGRIP

CGFG 51-P8

Blades for Face Machining
Carrying 8 mm Inserts

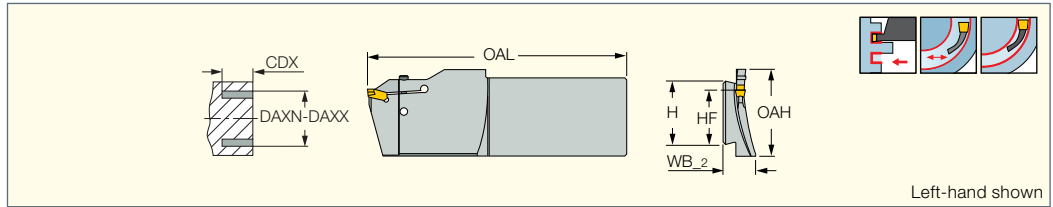

Designation	CW	DAXN ⁽¹⁾	DAXX ⁽²⁾	CDX	H	HF	OAL	OAH	WB_2		
CGFG 51-180R/L-P8	8.00	180.0	240.0	70.00	52.6	45.0	200.00	60.0	27.5	SR M4-2052	HW 3.0
CGFG 51-240R/L-P8	8.00	240.0	320.0	80.00	52.6	45.0	210.00	70.0	26.0	SR M4-2052	HW 3.0
CGFG 51-320R/L-P8	8.00	320.0	440.0	90.00	52.6	45.0	220.00	80.0	24.5	SR M4-2052	HW 3.0
CGFG 51-440R/L-P8	8.00	440.0	700.0	100.00	52.6	45.0	230.00	90.0	22.5	SR M4-2052	HW 3.0
CGFG 51-700R/L-P8	8.00	700.0	1500.0	120.00	52.6	45.0	250.00	100.0	20.0	SR M4-2052	HW 3.0

• For user guide, see pages 572-584

⁽¹⁾ Minimum penetration diameter

⁽²⁾ Maximum penetration diameter

For inserts, see pages: GIMF (271) • GIMM 8CC (565) • GIMY (272) • GIMY (full radius) (273) • GIMY-F (274) • GIPY (284)

For holders, see pages: SGTBK (587) • SGTBU/SGTBN (586)

CUTGRIP

GIFG-E (W=8)

Inserts for Deep Face
Grooving and Turning

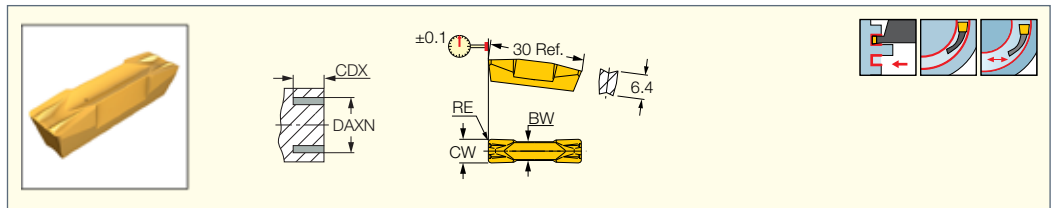

Designation	Dimensions						Tough ↔ Hard		Recommended Machining Data	
	CW	RE	CWTOL ⁽¹⁾	RETOL ⁽²⁾	DAXN ⁽³⁾	CDX	IC835	IC20		
GIFG 8.00E-0.80	8.00	0.80	0.02	0.050	50.0	25.00	6.00	•	•	f face-groove (mm/rev) 0.15-0.25
GIFG 8.00E-1.20	8.00	1.20	0.02	0.050	50.0	25.00	6.00	•	•	0.15-0.25

• For cutting speed recommendations, see pages 572-573

⁽¹⁾ Cutting width tolerance (+/-)

⁽²⁾ Corner radius tolerance (+/-)

⁽³⁾ Minimum axial grooving diameter

For tools, see pages: GAFG-R/L-8 (562) • GHFG-R/L-8 (561) • GHFGR/L-8 (561)

CUTGRIP

GIF-E (W=8,10)

Precision Double-Ended Inserts
for Grooving and Turning

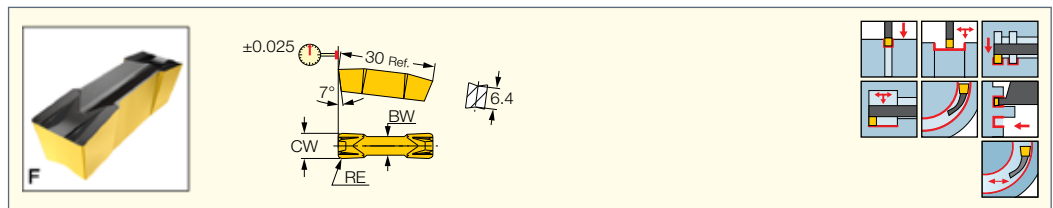

Designation	Dimensions						Tough ↔ Hard							Recommended Machining Data			
	CW	RE	CWTOL ⁽¹⁾	RETOL ⁽²⁾	BW	CDX	IC830	IC8250	IC808	IC20	IC5010	IC428	IC806	IC807	a _p (mm)	f turn (mm/rev)	f groove (mm/rev)
GIF 8.00E-0.40	8.00	0.40	0.02	0.030	6.00	27.00	•	•	•	•	•	•	•	•	0.50-4.80	0.29-0.48	0.18-0.31
GIF 8.00E-0.80	8.00	0.80	0.02	0.050	6.00	27.00	•	•	•	•	•	•	•	•	1.00-4.80	0.32-0.56	0.18-0.34
GIF 8.00E-1.20	8.00	1.20	0.02	0.050	6.00	27.00	•	•	•	•	•	•	•	•	1.45-4.80	0.32-0.62	0.18-0.34
GIF 10.00E-0.80	10.00	0.80	0.02	0.050	8.00	27.00	•	•	•	•	•	•	•	•	1.00-6.00	0.35-0.65	0.22-0.40
GIF 10.00E-1.20	10.00	1.20	0.02	0.050	8.00	27.00	•	•	•	•	•	•	•	•	1.45-6.00	0.35-0.72	0.22-0.40

• DMIN for internal machining = 65 mm • For cutting speed recommendations and user guide, see pages 572-584

⁽¹⁾ Cutting width tolerance (+/-)

⁽²⁾ Corner radius tolerance (+/-)

For tools, see pages: C#-GHDR/L (259) • CGHN-8-10D (270) • GADR/L-8 (269) • GADR/L-JHP (270) • GAFG-R/L-8 (562) • GHDR/L (long pocket) (268) • GHDR/L-JHP (long pocket) (268) • GHFG-R/L-8 (561) • GHFGR/L-8 (561) • GHIR/L (W=7.0-8.3) (339)

CUTGRIP

GIA-K (long pocket)

Flat Top Precision Double-Ended Inserts with T-Land for Machining Cast Iron

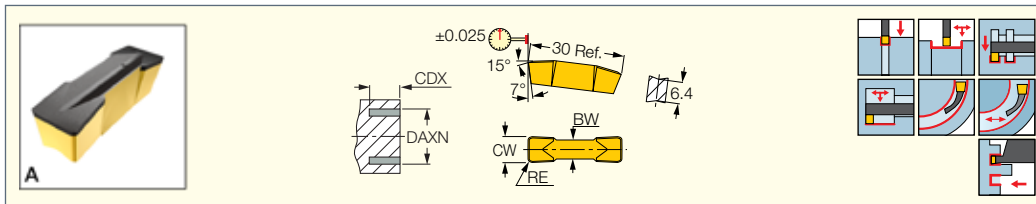

Designation	Dimensions							Tough ↔ Hard		Recommended Machining Data		
	CW	RE	CWTOL ⁽¹⁾	RETOL ⁽²⁾	BW	CDX ⁽³⁾	DAXN ⁽⁴⁾	IC5010	IC428	a _p (mm)	f turn (mm/rev)	f groove (mm/rev)
GIA 8.00K-0.80	8.00	0.80	0.02	0.050	6.00	25.00	160.0	●	●	1.00-4.80	0.36-0.64	0.18-0.38
GIA 8.00K-1.20	8.00	1.20	0.02	0.050	6.00	25.00	160.0	●	●	1.45-4.80	0.36-0.70	0.18-0.38

• DMIN for internal machining = 65 mm • For cutting speed recommendations and user guide, see pages 572-584

⁽¹⁾ Cutting width tolerance (+/-)

⁽²⁾ Corner radius tolerance (+/-)

⁽³⁾ Cutting depth maximum

⁽⁴⁾ Minimum axial grooving diameter

For tools, see pages: C#-GHDR/L (259) • CGHN-8-10D (270) • GADR/L-8 (269) • GADR/L-JHP (270) • GAFG-R/L-8 (562) • GHDR/L (long pocket) (268) • GHDR/L-JHP (long pocket) (268) • GHFG-R/L-8 (561) • GHFGR/L-8 (561) • GHIR/L (W=7.0-8.3) (339)

CUTGRIP

GDMY

Utility Double-Ended Inserts for Grooving and Turning

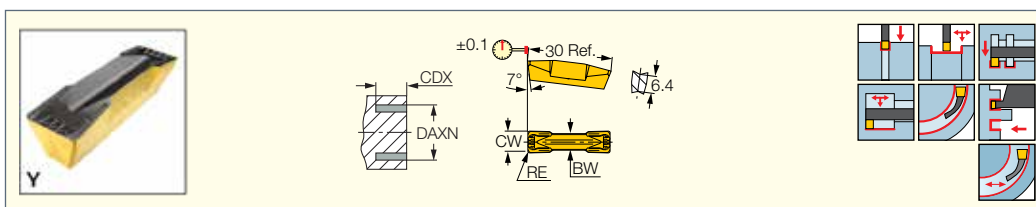

Designation	Dimensions							Tough ↔ Hard						Recommended Machining Data		
	CW	RE	CWTOL ⁽¹⁾	RETOL ⁽²⁾	BW	DAXN ⁽³⁾	CDX	IC830	IC8250	IC808	IC20	IC5010	IC428	a _p (mm)	f turn (mm/rev)	f groove (mm/rev)
GDMY 808	8.00	0.80	0.05	0.050	6.00	50.0	27.00	●	●	●	●	●	●	1.00-4.80	0.32-0.56	0.18-0.34

• DMIN for internal machining = 65 mm • For cutting speed recommendations and user guide, see pages 572-584

⁽¹⁾ Cutting width tolerance (+/-)

⁽²⁾ Corner radius tolerance (+/-)

⁽³⁾ Minimum axial grooving diameter

For tools, see pages: C#-GHDR/L (259) • CGHN-8-10D (270) • GADR/L-8 (269) • GADR/L-JHP (270) • GAFG-R/L-8 (562) • GHDR/L (long pocket) (268) • GHDR/L-JHP (long pocket) (268) • GHFG-R/L-8 (561) • GHFGR/L-8 (561) • GHIR/L (W=7.0-8.3) (339)

CUTGRIP

GDMY (full radius)

Utility Double-Ended Full Radius Inserts for Grooving and Profiling

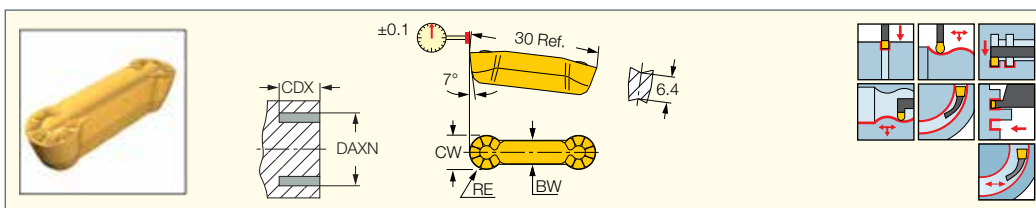

Designation	Dimensions							Tough ↔ Hard						Recommended Machining Data			
	CW	RE	CWTOL ⁽¹⁾	RETOL ⁽²⁾	BW	DAXN ⁽³⁾	CDX	IC830	IC8250	IC808	IC20	IC5010	IC428	IC806	a _p (mm)	f turn (mm/rev)	f groove (mm/rev)
GDMY 840	8.00	4.00	0.05	0.050	5.60	50.0	25.00	●	●	●	●	●	●	●	0.00-4.00	0.32-0.67	0.18-0.34

• Can cut arcs to 250° • DMIN for internal machining = 65 mm • For cutting speed recommendations and user guide, see pages 572-584

⁽¹⁾ Cutting width tolerance (+/-)

⁽²⁾ Corner radius tolerance (+/-)

⁽³⁾ Minimum axial grooving diameter

For tools, see pages: C#-GHDR/L (259) • CGHN-8-10D (270) • GADR/L-8 (269) • GADR/L-JHP (270) • GAFG-R/L-8 (562) • GHDKR/L (407) • GHDR/L (long pocket) (268) • GHDR/L-JHP (long pocket) (268) • GHFG-R/L-8 (561) • GHFGR/L-8 (561) • GHIR/L (W=7.0-8.3) (339)

CUTGRIP

GDMY-F

Utility Double-Ended Inserts for Grooving and Profiling Ductile Materials

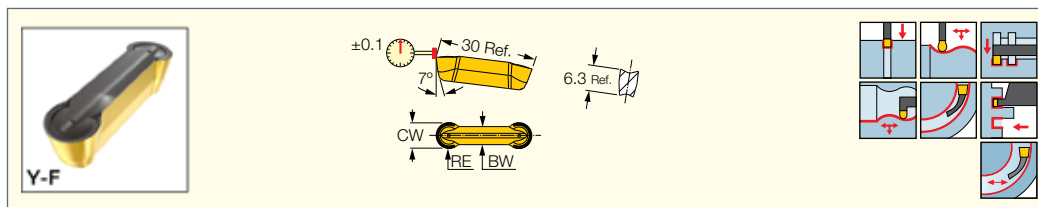

Designation	Dimensions						Tough ↔ Hard		Recommended Machining Data		
	CW	RE	CWTOL ⁽¹⁾	RETOL ⁽²⁾	BW	CDX	IC808	IC908	a _p (mm)	f turn (mm/rev)	f groove (mm/rev)
GDMY 840F	8.00	4.00	0.05	0.050	5.60	25.00	●	●	0.00-4.00	0.32-0.67	0.18-0.34

• DMIN for internal applications = 65 mm • For cutting speed recommendations and user guide, see pages 572-584

⁽¹⁾ Cutting width tolerance (+/-)

⁽²⁾ Corner radius tolerance (+/-)

For tools, see pages: C#-GHDR/L (259) • CGHN-8-10D (270) • GADR/L-8 (269) • GADR/L-JHP (270) • GAFG-R/L-8 (562) • GHDR/L (long pocket) (268) • GHDR/L-JHP (long pocket) (268) • GHFG-R/L-8 (561) • GHFGR/L-8 (561) • GHIR/L (W=7.0-8.3) (339)

CUTGRIP

GIMM 8CC

Single-Ended Utility Insert with a Frontal Chip Splitter for External Rough Grooving and Side Turning

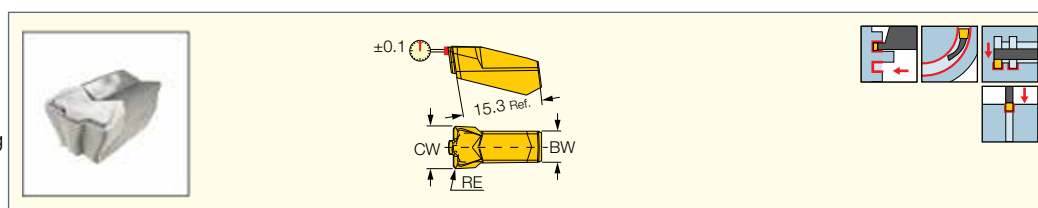

Designation	Dimensions					Tough ↔ Hard		Recommended Machining Data
	CW	RE	CWTOL ⁽¹⁾	RETOL ⁽²⁾	BW	IC808	IC908	f face-groove (mm/rev)
GIMM 8CC	8.00	0.80	0.05	0.050	5.80	●	●	0.30-0.45

• For cutting speed recommendations, see pages 572-573

⁽¹⁾ Cutting width tolerance (+/-)

⁽²⁾ Corner radius tolerance (+/-)

For tools, see pages: Anti-Vibration Blades (268) • CGFG 51-P8 (563) • CGHN-P8 (267) • CGHR/L-P8DG (267) • CGPAD (265) • GHDR/L (short pocket) (259) • GHDR/L-JHP (short pocket) (260) • GHDR/L-JHP-MC (short pocket) (261) • GHGR/L (262)

CUTGRIP

GDMM-CC

Single-Ended Utility Insert for External Rough Grooving and Side Turning with a Frontal Chip Splitter

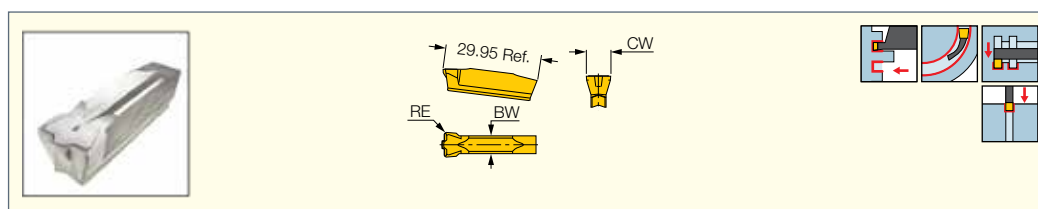

Designation	Dimensions					Tough ↔ Hard				Recommended Machining Data
	CW	RE	CWTOL ⁽¹⁾	RETOL ⁽²⁾	BW	IC830	IC354	IC808	IC907	f face-groove (mm/rev)
GDMM 7CC	7.00	0.80	0.05	0.050	6.00	●	●	●	●	0.30-0.45
GDMM 8CC	8.00	0.80	0.05	0.050	5.60	●	●	●	●	0.30-0.45

• For cutting speed recommendations, see pages 572-573

⁽¹⁾ Cutting width tolerance (+/-)

⁽²⁾ Corner radius tolerance (+/-)

For tools, see pages: C#-GHDR/L (259) • GADR/L-8 (269) • GADR/L-JHP (270) • GAFG-R/L-8 (562) • GHDR/L (long pocket) (268) • GHDR/L-JHP (long pocket) (268) • GHFG-R/L-8 (561) • GHFGR/L-8 (561) • GHIR/L (W=7.0-8.3) (339)



TNFFH-IQ
Face Grooving Blades

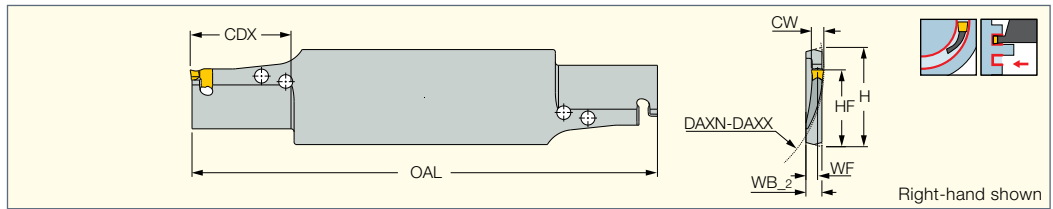

Designation	CW	DAXN ⁽¹⁾	DAXX ⁽²⁾	CDX	HF	H	WF	WB_2	OAL	Insert	
TNFFH 120R/L-3IQ	3.00	120.0	160.0	24.00	24.8	32.0	4.10	5.2	150.00	TNF 3...	ETF 3-6*
TNFFH 65R/L-3IQ	3.00	65.0	90.0	18.00	24.8	32.0	4.10	5.2	150.00	TNF 3...	ETF 3-6*
TNFFH 90R/L-3IQ	3.00	90.0	120.0	18.00	24.8	32.0	4.10	5.2	150.00	TNF 3...	ETF 3-6*
TNFFH 150R/L-4IQ	4.00	150.0	500.0	32.00	24.8	32.0	3.80	5.2	150.00	TNF 4...	ETF 3-6*
TNFFH 80R/L-4IQ	4.00	80.0	150.0	32.00	24.8	32.0	3.80	5.2	150.00	TNF 4...	ETF 3-6*
TNFFH 150R/L-5IQ	5.00	150.0	500.0	35.00	24.8	32.0	3.50	5.2	150.00	TNF 5...	ETF 3-6*
TNFFH 80R/L-5IQ	5.00	80.0	150.0	30.00	24.8	32.0	3.50	5.2	150.00	TNF 5...	ETF 3-6*
TNFFH 150R/L-6IQ	6.00	150.0	700.0	35.00	24.8	32.0	3.30	5.2	150.00	TNF 6...	ETF 3-6*
TNFFH 80R/L-6IQ	6.00	80.0	150.0	30.00	24.8	32.0	3.30	5.2	150.00	TNF 6...	ETF 3-6*

* H dimension links blades and blocks

⁽¹⁾ Minimum penetration diameter

⁽²⁾ Maximum penetration diameter

* Optional, should be ordered separately

For inserts, see pages: TNF-M-IQ (567) • TNF-P-IQ (567)



ETF 3-6 extractor (to be ordered separately).



TNFFA-IQ
Reinforced Face Grooving Blades

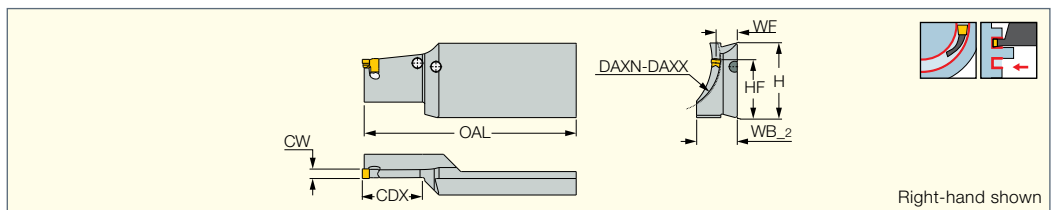

Designation	CW	DAXN ⁽¹⁾	DAXX ⁽²⁾	CDX	H	WF	HF	OAL	WB_2	Insert	
TNFFA 30R/L-3IQ	3.00	30.0	35.0	19.00	32.0	9.50	24.8	90.00	18.5	TNF 3...	ETF 3-6*
TNFFA 35L-3IQ	3.00	35.0	40.0	19.00	32.0	9.50	24.8	90.00	18.5	TNF 3...	ETF 3-6*
TNFFA 40R/L-3IQ	3.00	40.0	46.0	23.00	32.0	9.50	24.8	90.00	18.5	TNF 3...	ETF 3-6*
TNFFA 46L-3IQ	3.00	46.0	54.0	25.00	32.0	9.50	24.8	90.00	18.5	TNF 3...	ETF 3-6*
TNFFA 54R/L-3IQ	3.00	54.0	65.0	26.00	32.0	9.50	24.8	90.00	18.5	TNF 3...	ETF 3-6*
TNFFA 65R/L-3IQ	3.00	65.0	80.0	27.00	32.0	9.50	24.8	90.00	18.5	TNF 3...	ETF 3-6*
TNFFA 80R/L-3IQ	3.00	80.0	100.0	27.00	32.0	9.50	24.8	90.00	16.7	TNF 3...	ETF 3-6*
TNFFA 35R/L-4IQ	4.00	35.0	45.0	25.00	32.0	9.00	24.8	90.00	18.1	TNF 4...	ETF 3-6*
TNFFA 45R/L-4IQ	4.00	45.0	60.0	25.00	32.0	9.00	24.8	90.00	17.3	TNF 4...	ETF 3-6*
TNFFA 60R/L-4IQ	4.00	60.0	80.0	27.00	32.0	9.00	24.8	90.00	18.0	TNF 4...	ETF 3-6*
TNFFA 80R/L-4IQ	4.00	80.0	130.0	27.00	32.0	9.00	24.8	90.00	14.8	TNF 4...	ETF 3-6*
TNFFA 100R/L-5IQ	5.00	100.0	180.0	35.00	32.0	9.70	24.8	90.00	18.0	TNF 5...	ETF 3-6*
TNFFA 40R/L-5IQ	5.00	40.0	50.0	25.00	32.0	9.70	24.8	90.00	18.0	TNF 5...	ETF 3-6*
TNFFA 50R/L-5IQ	5.00	50.0	70.0	28.00	32.0	9.70	24.8	90.00	18.0	TNF 5...	ETF 3-6*
TNFFA 70R/L-5IQ	5.00	70.0	100.0	30.00	32.0	9.70	24.8	90.00	18.0	TNF 5...	ETF 3-6*
TNFFA 110R/L-6IQ	6.00	110.0	300.0	35.00	32.0	10.20	24.8	90.00	14.8	TNF 6...	ETF 3-6*
TNFFA 45R/L-6IQ	6.00	45.0	60.0	25.00	32.0	10.20	24.8	90.00	18.0	TNF 6...	ETF 3-6*
TNFFA 60R/L-6IQ	6.00	60.0	80.0	28.00	32.0	10.20	24.8	90.00	18.0	TNF 6...	ETF 3-6*
TNFFA 80R/L-6IQ	6.00	80.0	110.0	30.00	32.0	10.20	24.8	90.00	18.0	TNF 6...	ETF 3-6*

* For user guide, see pages 572-584

⁽¹⁾ Minimum penetration diameter

⁽²⁾ Maximum penetration diameter

* Optional, should be ordered separately

For inserts, see pages: TNF-M-IQ (567) • TNF-P-IQ (567)

TNF-P-IQ

Face Grooving Single-Ended Inserts for Machining Steel

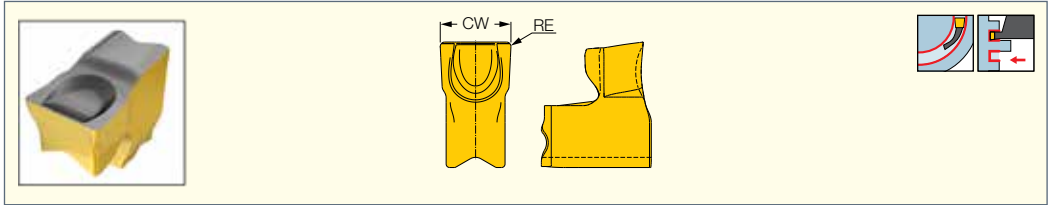

Designation	Dimensions			IC808	Recommended Machining Data
	CW	RE	CWTOL ⁽¹⁾		f face-groove (mm/rev)
TNF 3P-IQ	3.00	0.30	0.05	●	0.10-0.15
TNF 4P-IQ	4.00	0.25	0.05	●	0.10-0.15
TNF 5P-IQ	5.00	0.35	0.05	●	0.12-0.20
TNF 6P-IQ	6.00	0.35	0.05	●	0.12-0.20

• For user guide, see pages 572-584

⁽¹⁾ Cutting width tolerance (+/-)

For tools, see pages: TNFFA-IQ (566) • TNFFH-IQ (566)

TNF-M-IQ

Face Grooving Single-Ended Inserts for Machining Stainless Steel and High Temperature Alloys

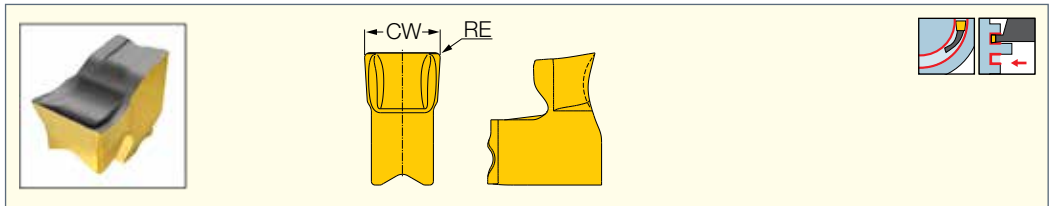

Designation	Dimensions			IC808	Recommended Machining Data
	CW	RE	CWTOL ⁽¹⁾		f face-groove (mm/rev)
TNF 3M-IQ	3.00	0.30	0.05	●	0.08-0.10
TNF 4M-IQ	4.00	0.25	0.05	●	0.08-0.12
TNF 5M-IQ	5.00	0.35	0.05	●	0.12-0.20
TNF 6M-IQ	6.00	0.35	0.05	●	0.12-0.20

• For user guide, see pages 572-584

⁽¹⁾ Cutting width tolerance (+/-)

For tools, see pages: TNFFA-IQ (566) • TNFFH-IQ (566)

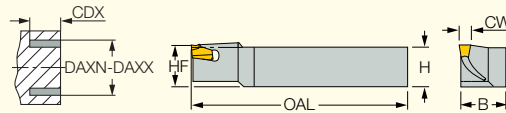
SGFFR/LFace Grooving Integral
Shank Tools

Left-hand shown

Designation	CW	H	B	CDX	DAXN ⁽¹⁾	DAXX ⁽²⁾	HF	OAL	Insert	
SGFFR/L 20-25-2	2.10	20.0	20.0	13.00	25.0	30.0	20.0	120.00	GFF 2R/L	ESG 0.5
SGFFR/L 20-30-2	2.10	20.0	20.0	14.00	29.0	36.0	20.0	120.00	GFF 2R/L	ESG 0.5
SGFFR/L 20-35-2	2.10	20.0	20.0	16.00	35.0	46.0	20.8	120.00	GFF 2N	ESG 0.5
SGFFR/L 20-45-2	2.10	20.0	20.0	20.00	45.0	61.0	20.8	120.00	GFF 2N	ESG 0.5
SGFFR/L 20-60-2	2.10	20.0	20.0	20.00	60.0	80.0	20.8	120.00	GFF 2N	ESG 0.5
SGFFR/L 25-35-2	2.10	25.0	25.0	16.00	35.0	46.0	25.8	130.00	GFF 2N	ESG 0.5
SGFFR/L 25-45-2	2.10	25.0	25.0	20.00	45.0	61.0	25.8	130.00	GFF 2N	ESG 0.5
SGFFR/L 25-60-2	2.10	25.0	25.0	20.00	60.0	80.0	25.8	130.00	GFF 2N	ESG 0.5
SGFFR 25-25-2	2.10	25.0	25.0	13.00	25.0	30.0	25.0	130.00	GFF 2N	ESG 0.5
SGFFR 25-30-2	2.10	25.0	25.0	14.00	29.0	36.0	25.0	130.00	GFF 2N	ESG 0.5
SGFFR/L 20-30-3	3.00	20.0	20.0	16.00	30.0	35.0	20.0	120.00	GFF 3R/L	ESG 0.5
SGFFR/L 20-35-3	3.00	20.0	20.0	18.00	34.4	40.6	20.0	120.00	GFF 3R/L	ESG 0.5
SGFFR/L 20-46-3	3.00	20.0	20.0	22.00	46.0	55.0	20.0	120.00	GFF 3R/L	ESG 0.5
SGFFR/L 25-35-3	3.00	25.0	25.0	18.00	34.4	40.6	25.0	130.00	GFF 3R/L	ESG 0.5
SGFFR/L 25-40-3	3.00	25.0	25.0	20.00	40.0	47.0	25.0	130.00	GFF 3R/L	ESG 0.5
SGFFR/L 25-55-3	3.00	25.0	25.0	24.00	54.0	65.0	26.2	130.00	GFF 3N	ESG 0.5
SGFFR 20-40-3	3.00	20.0	20.0	20.00	40.0	47.0	20.0	120.00	GFF 3R/L	ESG 0.5
SGFFR 20-55-3	3.00	20.0	20.0	22.00	54.0	65.0	21.2	120.00	GFF 3N	ESG 0.5
SGFFR 20-65-3	3.00	20.0	20.0	23.00	64.0	80.0	21.0	120.00	GFF 3N	ESG 0.5
SGFFR 20-80-3	3.00	20.0	20.0	24.00	79.0	100.0	20.7	120.00	GFF 3N	ESG 0.5
SGFFR 25-30-3	3.00	25.0	25.0	16.00	30.0	35.0	25.0	130.00	GFF 3R/L	ESG 0.5
SGFFR 25-46-3	3.00	25.0	25.0	22.00	46.0	55.0	25.0	130.00	GFF 3R/L	ESG 0.5
SGFFR 25-65-3	3.00	25.0	25.0	25.00	64.0	80.0	26.0	130.00	GFF 3N	ESG 0.5
SGFFR 25-80-3	3.00	25.0	25.0	26.00	79.0	100.0	25.7	130.00	GFF 3N	ESG 0.5
SGFFR/L 20-35-4	4.00	20.0	20.0	20.00	35.0	45.0	20.0	120.00	GFF 4N	ESG 0.5
SGFFR/L 20-45-4	4.00	20.0	20.0	25.00	44.0	58.0	20.0	120.00	GFF 4N	ESG 0.5
SGFFR/L 25-45-4	4.00	25.0	25.0	25.00	44.0	58.0	25.0	150.00	GFF 4N	ESG 0.5
SGFFR/L 25-60-4	4.00	25.0	25.0	26.00	57.0	80.0	25.0	150.00	GFF 4N	ESG 0.5
SGFFR/L 25-80-4	4.00	25.0	25.0	26.00	79.0	130.0	25.0	150.00	GFF 4N	ESG 0.5
SGFFR 20-60-4	4.00	20.0	20.0	25.00	57.0	80.0	20.0	120.00	GFF 4N	ESG 0.5
SGFFR 20-80-4	4.00	20.0	20.0	25.00	79.0	130.0	20.0	120.00	GFF 4N	ESG 0.5
SGFFR 25-35-4	4.00	25.0	25.0	20.00	35.0	45.0	25.0	150.00	GFF 4N	ESG 0.5
SGFFR/L 20-50-5	5.00	20.0	20.0	25.00	50.0	75.0	20.0	120.00	GFF 5N	ESG 0.5
SGFFR/L 25-100-5	5.00	25.0	25.0	30.00	100.0	180.0	25.0	150.00	GFF 5N	ESG 0.5
SGFFR/L 25-50-5	5.00	25.0	25.0	26.00	50.0	71.0	25.0	150.00	GFF 5N	ESG 0.5
SGFFR 20-75-5	5.00	20.0	20.0	26.00	74.0	130.0	20.0	120.00	GFF 5N	ESG 0.5
SGFFR 25-40-5	5.00	25.0	25.0	22.00	40.0	52.0	25.0	150.00	GFF 5N	ESG 0.5
SGFFR 25-70-5	5.00	25.0	25.0	28.00	69.0	102.0	25.0	150.00	GFF 5N	ESG 0.5
SGFFR/L 25-100-6	6.00	25.0	25.0	30.00	100.0	180.0	25.0	150.00	GFF 6N	ESG 0.5
SGFFR/L 25-60-6	6.00	25.0	25.0	30.00	57.0	77.0	25.0	150.00	GFF 6N	ESG 0.5
SGFFR/L 25-75-6	6.00	25.0	25.0	30.00	75.0	102.0	25.0	150.00	GFF 6N	ESG 0.5
SGFFR 20-60-6	6.00	20.0	20.0	25.00	57.0	60.0	20.0	120.00	GFF 6N	ESG 0.5

• Important: Apply R.H. insert on R.H. tool and L.H. insert on L.H. tool. Neutral insert only as indicated

⁽¹⁾ Minimum penetration diameter

⁽²⁾ Maximum penetration diameter

SGFFA

Reinforced Face Grooving Blades for Standard Tool Blocks

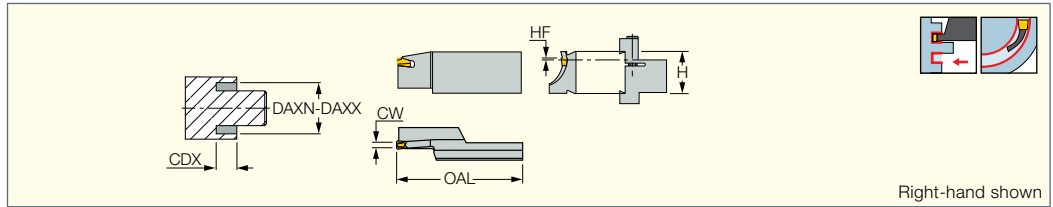

Designation	CW	CDX	DAXN ⁽¹⁾	DAXX ⁽²⁾	H	HF	OAL	
SGFFA 25-R/L-2	2.10	13.00	25.0	30.0	32.0	0.0	80.00	ESG 0.5
SGFFA 30-R/L-2	2.10	14.00	29.0	36.0	32.0	0.0	80.00	ESG 0.5
SGFFA 35-R/L-2	2.10	16.00	35.0	46.0	32.0	0.8	80.00	ESG 0.5
SGFFA 45-R/L-2	2.10	20.00	45.0	61.0	32.0	0.8	80.00	ESG 0.5
SGFFA 60-R/L-2	2.10	20.00	60.0	80.0	32.0	0.8	80.00	ESG 0.5
SGFFA 80-R/L-2	2.10	20.00	79.0	102.0	32.0	0.8	80.00	ESG 0.5
SGFFA 30-R/L-3	3.00	19.00	30.0	35.0	32.0	0.0	90.00	ESG 0.5
SGFFA 35-R/L-3	3.00	20.00	34.4	40.6	32.0	0.0	90.00	ESG 0.5
SGFFA 40-R/L-3	3.00	22.00	40.0	47.0	32.0	0.0	90.00	ESG 0.5
SGFFA 46-R/L-3	3.00	24.00	46.0	55.0	32.0	0.0	90.00	ESG 0.5
SGFFA 55-R/L-3	3.00	25.00	54.0	65.0	32.0	1.2	90.00	ESG 0.5
SGFFA 65-R/L-3	3.00	26.00	64.0	80.0	32.0	1.0	90.00	ESG 0.5
SGFFA 80-R/L-3	3.00	28.00	79.0	100.0	32.0	0.7	95.00	ESG 0.5
SGFFA 35-R/L-4	4.00	25.00	35.0	45.0	32.0	0.0	90.00	ESG 0.5
SGFFA 45-R/L-4	4.00	25.00	44.0	58.0	32.0	0.0	90.00	ESG 0.5
SGFFA 60-R/L-4	4.00	28.00	57.0	80.0	32.0	0.0	95.00	ESG 0.5
SGFFA 80-R/L-4	4.00	30.00	79.0	130.0	32.0	0.0	95.00	ESG 0.5
SGFFA 40-R/L-5	5.00	25.00	40.0	52.0	32.0	0.0	90.00	ESG 0.5
SGFFA 50-R/L-5	5.00	28.00	50.0	71.0	32.0	0.0	95.00	ESG 0.5
SGFFA 70-R/L-5	5.00	30.00	69.0	102.0	32.0	0.0	95.00	ESG 0.5
SGFFA 100-R/L-5	5.00	35.00	100.0	180.0	32.0	0.0	100.00	ESG 0.5
SGFFA 45-R/L-6	6.00	25.00	44.0	58.0	32.0	0.0	90.00	ESG 0.5
SGFFA 60-R/L-6	6.00	30.00	57.0	77.0	32.0	0.0	95.00	ESG 0.5
SGFFA 75-R/L-6	6.00	35.00	75.0	102.0	32.0	0.0	100.00	ESG 0.5
SGFFA 100-R/L-6	6.00	40.00	100.0	150.0	32.0	0.0	105.00	ESG 0.5
SGFFA 150-R/L-6	6.00	40.00	149.0	250.0	32.0	0.0	105.00	ESG 0.5

• Important: Apply R.H. insert on R.H. tool and L.H. insert on L.H. tool. Neutral insert only as indicated • B1 dimension links blades and blocks

⁽¹⁾ Minimum penetration diameter

⁽²⁾ Maximum penetration diameter

For inserts, see pages: GFF-N (570) • GFF-R/L (570)

SGFFH

Face Grooving Blades

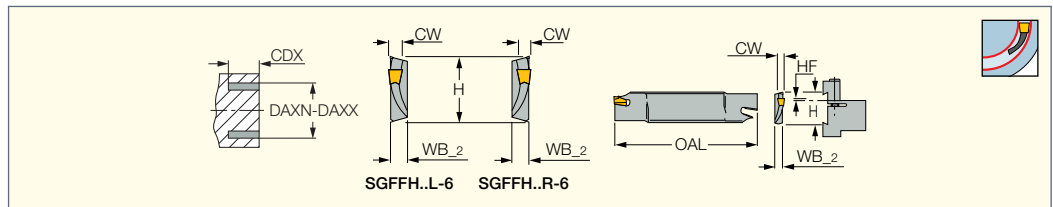

Designation	CW	CDX	DAXN ⁽¹⁾	DAXX ⁽²⁾	HF	H	WB_2	OAL	
SGFFH 35-R/L-2	2.10	20.00	35.0	46.0	0.8	32.0	5.2	150.00	ESG 0.5
SGFFH 45-R/L-2	2.10	20.00	45.0	61.0	0.8	32.0	5.2	150.00	ESG 0.5
SGFFH 60-R/L-2	2.10	20.00	60.0	80.0	0.8	32.0	5.2	150.00	ESG 0.5
SGFFH 80-R/L-2	2.10	20.00	79.0	102.0	0.8	32.0	4.0	150.00	ESG 0.5
SGFFH 100-R/L-2	2.10	20.00	101.0	132.0	0.0	32.0	4.0	150.00	ESG 0.5
SGFFH 75-R/L-3	3.00	20.00	65.0	92.0	1.0	32.0	5.2	150.00	ESG 0.5
SGFFH 90-R/L-3	3.00	20.00	90.0	122.0	0.2	32.0	5.2	150.00	ESG 0.5
SGFFH 120-R/L-3	3.00	25.00	120.0	160.0	0.0	32.0	5.2	150.00	ESG 0.5
SGFFH 80-R/L-4	4.00	30.00	80.0	155.0	2.5	32.0	5.2	150.00	ESG 0.5
SGFFH 150-R/L-4	4.00	30.00	150.0	500.0	2.5	32.0	5.2	150.00	ESG 0.5
SGFFH 80-R/L-5	5.00	32.00	80.0	162.0	0.0	32.0	5.2	150.00	ESG 0.5
SGFFH 150-R/L-5	5.00	35.00	150.0	600.0	0.0	32.0	5.2	150.00	ESG 0.5
SGFFH 90-R/L-6	6.00	32.00	90.0	150.0	0.0	32.0	8.0	150.00	ESG 0.5
SGFFH 150-R/L-6	6.00	35.00	148.0	700.0	0.0	32.0	5.2	150.00	ESG 0.5

• Important: Apply R.H. insert on R.H. tool and L.H. insert on L.H. tool. Neutral insert only as indicated • H dimension links blades and blocks

⁽¹⁾ Minimum penetration diameter

⁽²⁾ Maximum penetration diameter

For inserts, see pages: GFF-N (570)

SELFGRIP

GFF-R/L
Face Grooving Inserts

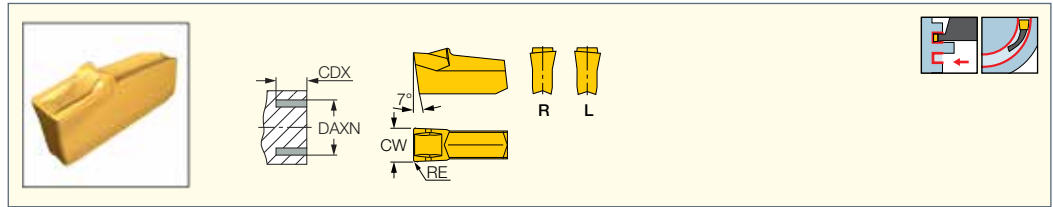

Designation	Dimensions						Tough ↔ Hard		Recommended Machining Data
	CW	RE	CWTOL ⁽¹⁾	RETOL ⁽²⁾	DAXN ⁽³⁾	DAXX ⁽⁴⁾	IC354	IC20	
GFF 2R	2.10	0.20	0.10	0.050	25.0	36.0	●	●	f face-groove (mm/rev)
GFF 3R/L	3.00	0.30	0.10	0.050	30.0	55.0	●	●	0.03-0.13
									0.03-0.15

- (1) Cutting width tolerance (+/-)
 - (2) Corner radius tolerance (+/-)
 - (3) Minimum axial grooving diameter
 - (4) Maximum axial grooving diameter
- For tools, see pages: SGFFA (569) • SGFFR/L (568)

SELFGRIP

GFF-N
Face Grooving Inserts

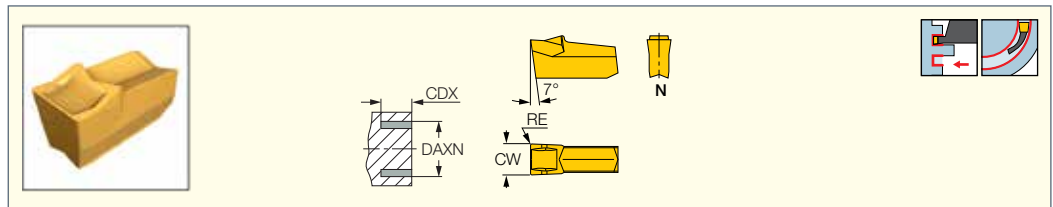

Designation	Dimensions						Tough ↔ Hard		Recommended Machining Data
	CW	RE	CWTOL ⁽¹⁾	RETOL ⁽²⁾	DAXN ⁽³⁾	DAXX ⁽⁴⁾	IC354	IC20	
GFF 2N	2.10	0.20	0.10	0.050	35.0		●	●	f face-groove (mm/rev)
GFF 3N	3.00	0.30	0.10	0.050	54.0		●	●	0.03-0.13
GFF 4N	4.00	0.25	0.10	0.050	35.0		●	●	0.03-0.15
GFF 5N	5.00	0.25	0.10	0.050	40.0		●	●	0.04-0.18
GFF 6N	6.00	0.25	0.10	0.050	44.0		●	●	0.05-0.18
									0.05-0.20

- Grooving depth is limited only by the tool being used
 - (1) Cutting width tolerance (+/-)
 - (2) Corner radius tolerance (+/-)
 - (3) Minimum axial grooving diameter
- For tools, see pages: SGFFA (569) • SGFFH (569) • SGFFR/L (568)

PENTACUT
PARTING & GROOVING LINE

PENTA 34F-R/L
Pentagonal Inserts for Face Grooving and Recessing

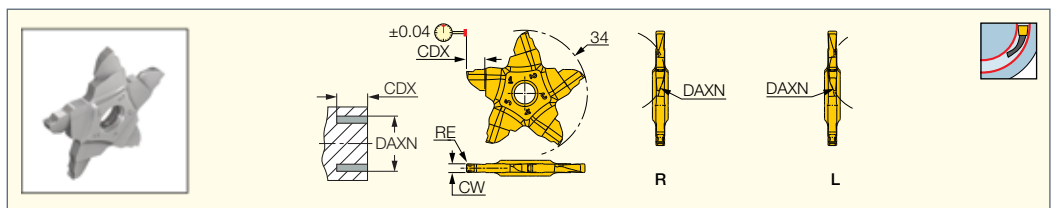

Designation	Dimensions						IC908	Recommended Machining Data
	CW	RE	RETOL ⁽¹⁾	CDX	DAXN ⁽²⁾	DAXX ⁽²⁾		
PENTA 34F239-0.15-22R/L	2.39	0.15	0.020	5.00	22.0		●	f face-groove (mm/rev)
PENTA 34F247-0.20-22R/L	2.47	0.20	0.020	5.00	22.0		●	0.08-0.12
PENTA 34F300-0.40-22R/L	3.00	0.40	0.020	5.00	22.0		●	0.08-0.12
PENTA 34F400-0.40-22R/L	4.00	0.40	0.020	5.00	22.0		●	0.08-0.15
								0.08-0.15

- For cutting speed recommendations, see pages 572-573
 - (1) Corner radius tolerance (+/-)
 - (2) Minimum axial grooving diameter
- For tools, see pages: PCADR/L (300) • PCADR/L 34N-RE (301) • PCHBR/L (302) • PCHPR/L (300) • PCHR/L-34 (299) • PCHR/L-34-JHP (299)

PCHPR/L

Perpendicular Holders
Carrying Inserts with 5 Cutting
Edges for Facing, Grooving,
Parting and Recessing

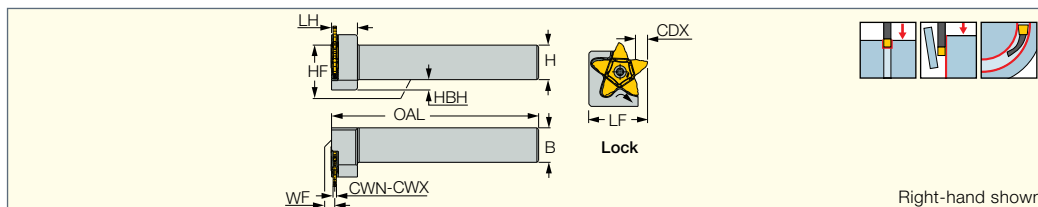

Designation	H	B	CWN ⁽¹⁾	CWX ⁽²⁾	CDX ⁽³⁾	HF	WF	LF	OAL	LH	HBH		
PCHPR/L 16-24	16.0	16.0	0.50	3.20 ⁽⁴⁾	6.50	16.0	1.50 ⁽⁵⁾	23.5	120.00	11.5	-	SR 16-212-01397	T-20/5
PCHPR/L 20-24	20.0	20.0	0.50	3.20 ⁽⁴⁾	6.50	20.0	1.50 ⁽⁵⁾	28.0	120.00	11.5	-	SR 16-212-01397	T-20/5
PCHPR/L 25-24	25.0	25.0	0.50	3.20 ⁽⁴⁾	6.50	25.0	1.50 ⁽⁵⁾	33.0	135.00	11.5	-	SR 16-212-01397	T-20/5
PCHPR/L 20-34	20.0	20.0	1.40	4.00	10.00	20.0	1.90	34.0	120.00	15.0	6.0	SR 16-212-01397	T-20/5
PCHPR/L 25-34	25.0	25.0	1.40	4.00	10.00	25.0	1.90	34.0	135.00	15.0	-	SR 16-212-01397	T-20/5

- (1) Minimum cutting width
- (2) Maximum cutting width
- (3) For specific information, refer to insert data.
- (4) Up to 6.2 mm width may be ordered on request.
- (5) Valid for inserts with CW<3.2 mm

For inserts, see pages: PENTA 24-BSPT (309) • PENTA 24-ISO (308) • PENTA 24-MT (309) • PENTA 24-NPT (630) • PENTA 24-UN (308) • PENTA 24-W (308) • PENTA 24-WT (309) • PENTA 24N-C (304) • PENTA 24N-C (full radius) (305) • PENTA 24N-J (303) • PENTA 24N-J (full radius) (304) • PENTA 24N-PF (full radius) (306) • PENTA 24N-PF/P (305) • PENTA 24N-Z (306) • PENTA 24R-C (480) • PENTA 24R-P (482) • PENTA 24R/L-J (480) • PENTA 24R/L-Z (481) • PENTA 34F-R/L (670) • PENTA 34N-C (310) • PENTA 34N-J (311) • PENTA 34N-PB (310) • PENTA 34R/L-C (482) • PENTA 34R/L-J (483) • PENTA 34R/L-PB (483)

PENTA 34F-RS/LS

Pentagonal Inserts for Face
Grooving and Recessing Along
Shafts up to 5 mm Depth of Cut
at a Minimum of 22 mm Diameter

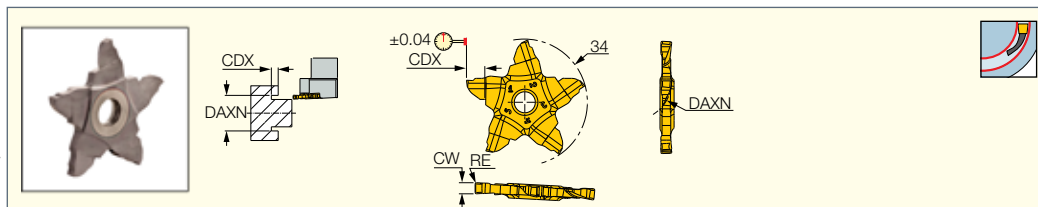

Designation	Dimensions				IC908	Recommended Machining Data
	CW	RE	CDX	DAXN ⁽¹⁾		
PENTA 34F239-0.15-22R/LS	2.39	0.15	5.00	22.0	●	f face-groove (mm/rev) 0.08-0.12
PENTA 34F247-0.20-22R/LS	2.47	0.20	5.00	22.0	●	0.08-0.12
PENTA 34F300-0.40-22R/LS	3.00	0.40	5.00	22.0	●	0.08-0.15
PENTA 34F400-0.40-22R/LS	4.00	0.40	5.00	22.0	●	0.08-0.15

• For cutting speed recommendations, see pages 572-573

- (1) Minimum axial grooving diameter

For tools, see pages: PCHPRS/LS (571)

PCHPRS/LS

Perpendicular Shank
Tools Carrying Pentagonal
Inserts for Machining Next
to Long Central Shafts

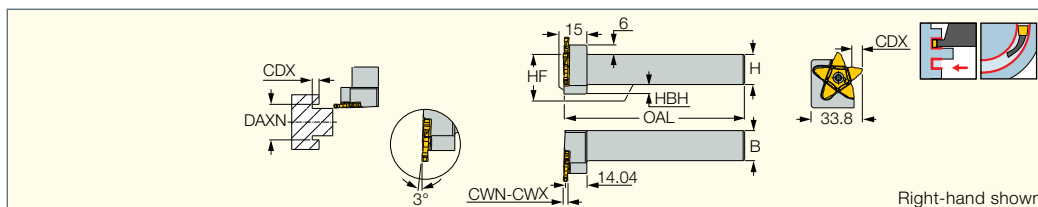

Designation	H	B	CWN ⁽¹⁾	CWX ⁽²⁾	OAL	HBH	CDX ⁽³⁾	HF		
PCHPR/LS 20-34	20.0	20.0	2.39	4.00	120.00	6.0	5.00	20.0	SR 16-212-01397RS	T-20/5
PCHPR/LS 25-34	25.0	25.0	2.39	4.00	135.00	-	5.00	25.0	SR 16-212-01397RS	T-20/5

- (1) Minimum cutting width
- (2) Maximum cutting width
- (3) Insert limit

For inserts, see pages: PENTA 34F-RS/LS (571)

Machining Data for Face Machining

ISO	Material	Condition	Tensile Strength [N/mm ²]	Hardness HB	Material No.	
P	Non-alloy steel and cast steel, free cutting steel	< 0.25 %C	Annealed	420	125	1
		>= 0.25 %C	Annealed	650	190	2
		< 0.55 %C	Quenched and tempered	850	250	3
		>= 0.55 %C	Annealed	750	220	4
	Low alloy steel and cast steel (less than 5% of alloying elements)	Quenched and tempered	1000	300	5	
		Annealed	600	200	6	
		Quenched and tempered	930	275	7	
			1000	300	8	
			1200	350	9	
	High alloyed steel, cast steel, and tool steel	Annealed	680	200	10	
		Quenched and tempered	1100	325	11	
	Stainless steel and cast steel	Ferritic/martensitic	680	200	12	
		Martensitic	820	240	13	
M	Stainless steel	Austenitic	600	180	14	
K	Grey cast iron (GG)	Ferritic/pearlitic		180	15	
		Pearlitic		260	16	
	Cast iron nodular (GGG)	Ferritic		160	17	
		Pearlitic		250	18	
	Malleable cast iron	Ferritic		130	19	
		Pearlitic		230	20	
N	Aluminum-wrought alloy	Not cureable		60	21	
		Cured		100	22	
	Aluminum-cast, alloyed	<=12% Si	Not cureable		75	23
			Cured		90	24
		>12% Si	High temperature		130	25
			>1% Pb	Free cutting		110
	Copper alloys	Brass		90	27	
		Electrolytic copper		100	28	
		Duroplastics, fiber plastics			29	
	Non-metallic	Hard rubber			30	
S	High temp. alloys	Fe based	Annealed	200	31	
			Cured	280	32	
		Ni or Co based	Annealed	250	33	
			Cured	350	34	
			Cast	320	35	
	Titanium Ti alloys		RM 400	36		
		Alpha+beta alloys cured	RM 1050	37		
H	Hardened steel	Hardened		55 HRC	38	
		Hardened		60 HRC	39	
	Chilled cast iron	Cast		400	40	
	Cast iron	Hardened		55 HRC	41	

Material No.	IC228/528	IC830	IC354	IC908	IC808	IC8250
1	85 - 125	90 - 135	95 - 145	120 - 180	125 - 190	180 - 270
2	75 - 110	80 - 115	90 - 125	110 - 155	115 - 165	165 - 230
3	60 - 85	65 - 95	70 - 100	85 - 125	90 - 130	125 - 185
4	65 - 100	70 - 110	75 - 115	95 - 145	100 - 150	140 - 215
5	50 - 85	55 - 90	60 - 95	75 - 120	80 - 125	110 - 180
6	65 - 100	70 - 110	75 - 115	95 - 145	100 - 150	140 - 215
7	50 - 85	55 - 95	60 - 100	75 - 125	80 - 130	110 - 185
8	50 - 85	55 - 90	60 - 95	75 - 120	80 - 125	110 - 180
9	50 - 75	50 - 80	55 - 90	70 - 110	75 - 115	105 - 165
10	75 - 110	80 - 115	90 - 125	110 - 155	115 - 165	165 - 230
11	50 - 75	50 - 80	55 - 90	70 - 110	75 - 115	105 - 165
	IC806	IC808	IC354	IC830	IC20	
12	110 - 200	100 - 180	80 - 145	75 - 135	50 - 90	
13	100 - 185	90 - 170	70 - 135	65 - 125	45 - 85	
	IC806	IC808	IC354	IC830	IC20	
14	90 - 170	80 - 155	65 - 125	60 - 115	40 - 75	
	IC5010	IC428	IC8250	IC808	IC20	
15	135 - 255	125 - 230	110 - 205	85 - 160	60 - 115	
16	120 - 180	110 - 160	100 - 145	75 - 110	55 - 80	
17	130 - 215	120 - 195	110 - 175	85 - 135	60 - 95	
18	105 - 170	95 - 155	85 - 140	65 - 110	45 - 75	
19	160 - 265	145 - 240	130 - 215	100 - 170	70 - 120	
20	130 - 215	120 - 195	110 - 175	85 - 135	60 - 95	
	IC808	IC20				
21	330 - 990	300 - 900				
22	250 - 825	225 - 750				
23	250 - 825	225 - 750				
24	165 - 495	150 - 450				
25	165 - 330	150 - 300				
26	165 - 330	150 - 300				
27	120 - 250	110 - 225				
28	80 - 165	75 - 150				
29	40 - 165	35 - 150				
30						
	IC806	IC908	IC808	IC830	IC20	
31	45 - 70	35 - 55	35 - 60	25 - 40	25 - 40	
32	30 - 50	25 - 40	25 - 40	20 - 30	15 - 30	
33	30 - 50	25 - 40	25 - 40	20 - 30	15 - 30	
34	25 - 45	20 - 35	20 - 35	15 - 25	15 - 25	
35	20 - 30	15 - 25	15 - 25	10 - 20	10 - 15	
36	105 - 180	85 - 145	90 - 150	65 - 110	60 - 100	
37	40 - 50	30 - 40	30 - 40	25 - 35	35 - 45	
	IC808	IC20				
38	25-30	20-30				
39	20-30	15-25				
40	30-45	30-40				
41	25-30	25-30				

Machining Data for Face Machining

ISO	Material	Condition	Tensile Strength [N/mm ²]	Hardness HB	Material No.	
P	Non-alloy steel and cast steel, free cutting steel	< 0.25 %C	Annealed	420	125	1
		>= 0.25 %C	Annealed	650	190	2
		< 0.55 %C	Quenched and tempered	850	250	3
		>= 0.55 %C	Annealed	750	220	4
		Quenched and tempered	1000	300	5	
	Low alloy steel and cast steel (less than 5% of alloying elements)	Annealed	600	200	6	
			930	275	7	
		Quenched and tempered	1000	300	8	
			1200	350	9	
	High alloyed steel, cast steel, and tool steel	Annealed	680	200	10	
		Quenched and tempered	1100	325	11	
	Stainless steel and cast steel	Ferritic/martensitic	680	200	12	
		Martensitic	820	240	13	
M	Stainless steel	Austenitic	600	180	14	
K	Grey cast iron (GG)	Ferritic/pearlitic		180	15	
		Pearlitic		260	16	
	Cast iron nodular (GGG)	Ferritic		160	17	
		Pearlitic		250	18	
	Malleable cast iron	Ferritic		130	19	
		Pearlitic		230	20	
N	Aluminum-wrought alloy	Not cureable		60	21	
		Cured		100	22	
	Aluminum-cast, alloyed	<=12% Si	Not cureable		75	23
		Cured		90	24	
	Copper alloys	>12% Si	High temperature		130	25
		>1% Pb	Free cutting		110	26
			Brass		90	27
			Electrolytic copper		100	28
Non-metallic	Duroplastics, fiber plastics				29	
	Hard rubber				30	
S	High temp. alloys	Fe based	Annealed		200	31
			Cured		280	32
		Ni or Co based	Annealed		250	33
			Cured		350	34
			Cast		320	35
	Titanium Ti alloys		RM 400			36
		Alpha+beta alloys cured	RM 1050			37
H	Hardened steel	Hardened		55 HRC	38	
		Hardened		60 HRC	39	
	Chilled cast iron	Cast		400	40	
	Cast iron	Hardened		55 HRC	41	

Cutting Speed (m/min)	GFQR IC528 Feed (mm/rev)	PICCO IC228 Feed (mm/rev)	MIFR/MEFL 8 IC908 Feed (mm/rev)	MIFR 10 IC908 Feed (mm/rev)	MIFR 15 IC908 Feed (mm/rev)
80-180	0.02-0.08	0.015-0.05	0.015-0.08	0.03-0.10	0.03-0.08
80-130	0.02-0.06	0.015-0.04			
80-120	0.02-0.06	0.015-0.04			
80-140	0.02-0.08	0.015-0.04			
80-140	0.02-0.08	0.015-0.04			
80-120	0.02-0.06	0.015-0.03			
80-120	0.02-0.05	0.015-0.03			
80-140	0.02-0.08	0.015-0.04			
80-120	0.02-0.08	0.015-0.03			
40-120	0.02-0.08	0.015-0.04	0.015-0.07	0.03-0.08	0.02-0.05
40-120	0.02-0.07	0.015-0.04	0.015-0.07	0.03-0.08	0.02-0.05
40-100	0.02-0.06	0.015-0.03	0.015-0.07	0.03-0.08	0.02-0.05
80-140	0.02-0.08	0.015-0.05	0.02-0.10	0.05-0.12	0.04-0.10
80-120	0.02-0.07	0.015-0.04			
80-140	0.02-0.08	0.015-0.04			
80-120	0.02-0.07	0.015-0.04			
80-140	0.02-0.06	0.015-0.04			
80-120	0.02-0.07	0.015-0.04			
150-320	0.02-0.08	0.015-0.05	0.02-0.10	0.05-0.15	0.05-0.12
100-250	0.02-0.08	0.015-0.05			
150-300	0.02-0.08	0.015-0.05			
150-300	0.02-0.08	0.015-0.05			
100-150	0.02-0.08	0.015-0.05			
80-230	0.02-0.08	0.015-0.05			
70-200	0.02-0.08	0.015-0.05			
50-180	0.02-0.08	0.015-0.05			
20-40	0.02-0.06	0.015-0.04	0.015-0.7	0.02-0.08	0.02-0.05
15-30	0.02-0.06	0.015-0.04			
15-20	0.02-0.06	0.015-0.04			
15-20	0.02-0.06	0.015-0.04			
15-20	0.02-0.06	0.015-0.04			
40-120	0.02-0.06	0.015-0.04			
20-50	0.02-0.06	0.015-0.04			

Grades	ISO	Coating Layers
IC354	P20-P40 M20-M30	TiCN
S.T. IC806	S05-S15 M05-M15	TiAlN AlTiN
S.T. IC807	P10-P20 M05-M15 S10-S20 K15-K30 H05-H15	TiN TiAlN
S.T. IC808	P15-P30 M20-M30 S15-S30 K20-K40 H20-H30	TiN TiAlN
S.T. IC830	P30-P45 M25-M45	TiN TiAlN
IC908	P15-P30 M20-M30 S15-S30 K20-K40 H20-H30	TiAlN
S.T. IC5010	K10-K25	TiN Al ₂ O ₃ TiCN
S.T. IC8250	P10-P35 M15-M25	TiN Al ₂ O ₃ TiCN
IC418	K10-K25	Al ₂ O ₃ TiC
IC428	K05-K20	Al ₂ O ₃ TiC
IC9015	P05-P25 K10-K15	Al ₂ O ₃ TiCN

S.T. SUMO TEC ■ PVD COATED ■ CVD COATED

Grades	ISO	Coating Layers
IC08	M10-M30 N10-N25 S15-S30	
IC20	N05-N25 S10-S25 K10-K20 H10-H20	

■ CERMET ■ UNCOATED

Recommended Applications

TiCN PVD coated grade on tough substrate used for general facing applications on wide range of carbon and alloy steels at medium speeds.

A hard submicron substrate with **AlTiN + TiAlN PVD** coating and a special **SUMO TEC** surface treatment. First choice for machining of high temperature alloys. Suitable also for Titanium alloys, at medium to relatively high cutting speeds.

A hard submicron substrate with **TiAlN + TiN PVD** coating and a special **SUMO TEC** surface treatment. Suitable for machining high temperature alloys, austenitic stainless steel and hard steels at medium cutting speeds.

A tough submicron substrate with **TiAlN + TiN PVD** coating and a special **SUMO TEC** surface treatment. Recommended for face machining on large variety of materials as well as high temperature alloys, stainless steel and hard steels at low to medium cutting speeds.

TiAlN + TiN PVD coated grade with a special **SUMO TEC** surface treatment on very tough substrate for machining of steel and stainless steel at low to medium speeds and medium to high feeds. The grade is recommended for interrupted cut and machining at unstable conditions.

A tough submicron substrate with **TiAlN PVD** coating. Recommended for general use in facing operations on large variety of materials as steels, high temperature alloys, stainless steel and hard steels at low to medium cutting speeds.

A **TiCN + Al₂O₃** multilayer, **CVD** coated grade with a special **SUMO TEC** surface treatment. Used for machining grey and nodular cast iron at medium to high cutting speeds. Can be used for interrupted cuts and heavy machining.

A tough substrate with a cobalt enriched layer combined with **MTCVD TiCN** and a thick alpha **Al₂O₃ CVD** coating with a special **SUMO TEC** surface treatment. Recommended for general use machining of steels and martensitic stainless steel in a wide range of conditions, features high toughness and wear resistance.

A **Tic + Al₂O₃** multilayer **CVD** coated grade. Used for machining grey and nodular cast iron at medium to high cutting speeds. Can be used for interrupted cuts and heavy machining.

Tic + Al₂O₃ multilayer **CVD** coated grade. Used for machining grey and nodular cast iron at medium to high cutting speeds.

A hard substrate with a cobalt enriched layer, **MTCVD TiCN** and a thick **Al₂O₃ CVD** coating. Recommended for high speed machining of steels at stable conditions.

Recommended Applications

An uncoated submicron carbide grade, used for steels, stainless steel and high temperature alloys at low cutting speeds.

An uncoated carbide grade. Used for machining of Aluminum and other nonferrous materials at medium to high cutting speeds. Suitable also for high temperature and Titanium alloys machining at low cutting speeds.

Clamping the Insert

Clamping an insert correctly into the holder is necessary for stable machining.

- Be sure that the seat is clean of dirt and swarf.
- At the first stage of clamping, ease the insert gently into place. Make sure that the prismatic surfaces match.

• Screw Clamping Torque

Insert Width	Nxm
3	4-5
4	5-6
5	6-7
6/8	7-9
CGFG 51...	4-6

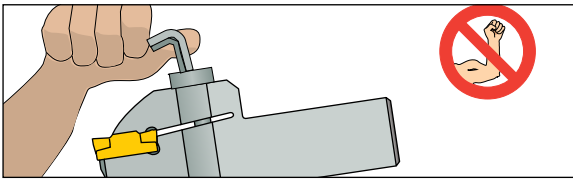
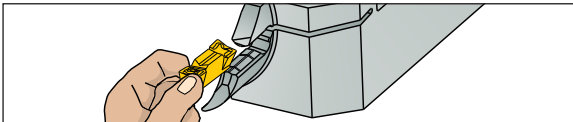
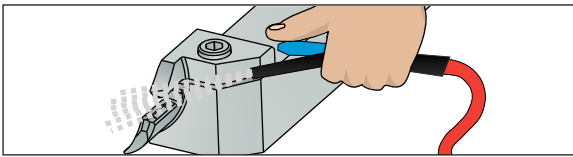

The unique chipformer is designed for deep grooving and face turning both toward and away from center, with excellent chip formation.



HELIFACE HFPR/L & HGPL Type

For general use in turning & grooving on all types of materials. Use for deep grooving in low-to-medium feeds 0.04-0.15 mm/rev. Min grooving dia. 12 mm.



HELI-GRIP GRIP...Y Type

The "all in one" insert for parting, external grooving and turning, internal grooving and turning, face grooving and turning.



DO-GRIP DGN...C Type

For grooving operations only. Strong cutting edge for hard materials and tough applications in feeds 0.1-0.2 mm/rev.



DO-GRIP DGN...J Type

For grooving operations only. Positive rake, for soft materials in low-to-medium feeds 0.05-0.15 mm/rev.

Face Machining Guide

Tool Selection - Follow these recommendations to choose the right tool for high performance

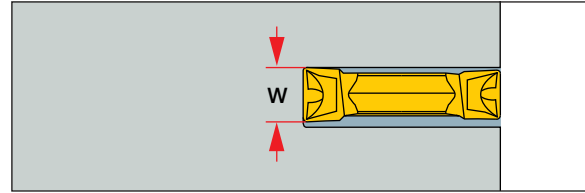

Choose the widest possible insert and tool, according to the cutting width and geometry to be machined.

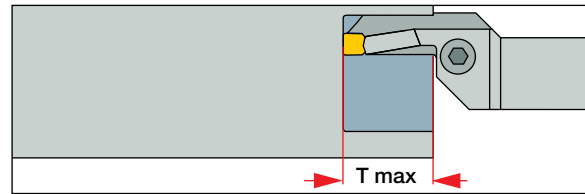

Choose the shortest tool blade overhang, according to the maximum depth required.

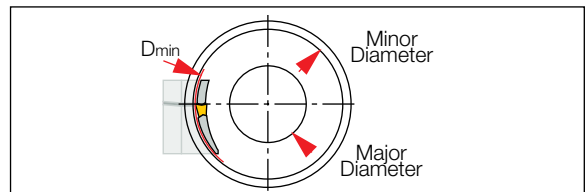

Choose the tool range with the largest diameter, depending on the initial grooving diameter required in the application.

Remark: On integral shank tools the given range refers to the holder capacity.

Tool Adjustment - Prior to machining, check and adjust the following tool positions.

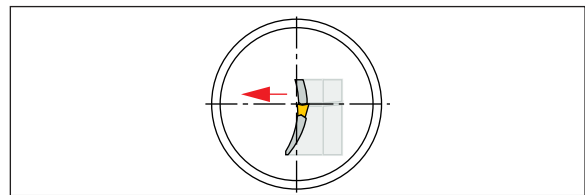

Check the cutting edge height at center line, machine in light turning down to center and check for burr.

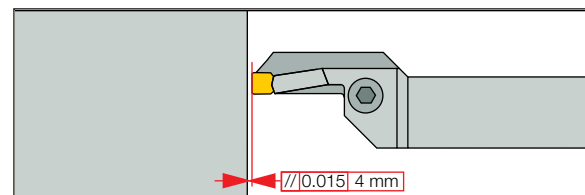

Check parallelism of the cutting edge and machined surface. Correct position can guarantee good surface quality when face turning in both directions.

Face Machining Guide

Recommended machining sequence in roughing operation using multifunction HELIFACE tools

1 Groove at the initial diameter up to the depth of cut selected for next step in face turning.

2 Continue with face turning away from center.

3 After rapid positioning back into initial groove, continue with face turning to center.

Note: When face grooving, reduce the speed by 40% in relation to that used in face turning.

Optimizing the Machining Sequence

Recommended machining sequence using multifunction tools

1 Groove at the initial diameter to the final depth of groove and continue face turning away from center to the tangential point on the radius.

2 Finish major diameter toward the bottom and generate the radius.

3 Position the tool in rapid movement in the initial groove, continue face turning to center, without touching the machined roughing steps on the wall.

4 Finish boring the minor diameter to the bottom, up to final depth.

Note: When face grooving, reduce the speed by 40% in relation to that used in face turning.

The Multifunction Advantage

1

The **HELIFACE** internal boring bar **HFIR/L MC** type with internal coolant can replace the three different **ISO** tools and shorten machining time by 20%.

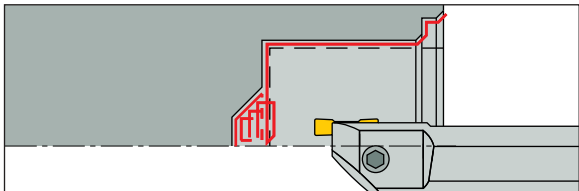

2

A single multifunction tool machines the whole part: grooving, face turning and chamfering, replacing three **ISO** tools and reducing machining time by 40%.

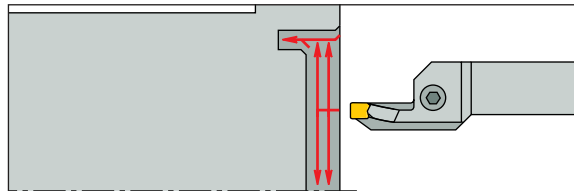

3

A single integral **HELIFACE** tool **HFHPL-M** replaces three **ISO** tools and reduces machining time by 50%.

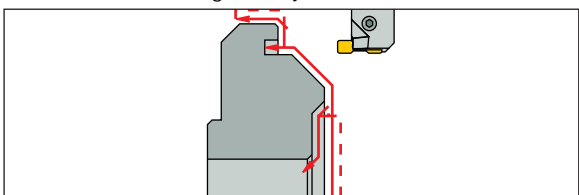

The Multifunction Advantage

This workpiece was machined using three different conventional tools.

1

An indexable drill for bottom drilling.

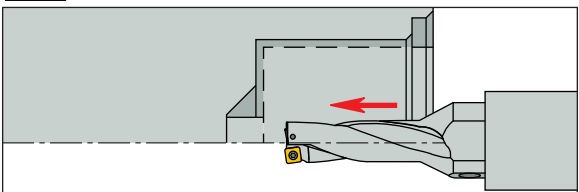

2

A standard internal boring bar with trigon insert for roughing and finishing.

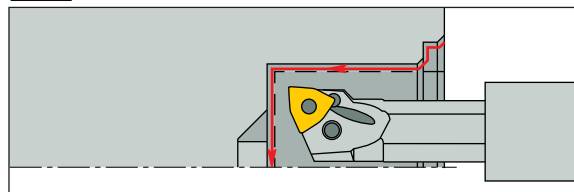

3

A standard internal boring bar with trigon insert for bottom machining. This operation requires a small diameter shank and long overhang.

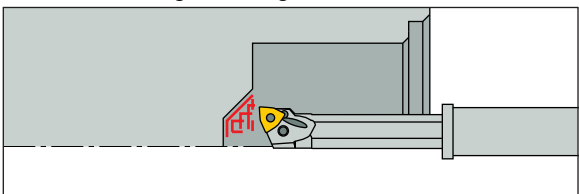

The **HELIFACE** Solution

The **HELIFACE** internal boring bar **HFIR/L MC** type with internal coolant can replace the three different **ISO** tools and shorten machining time by 20%.

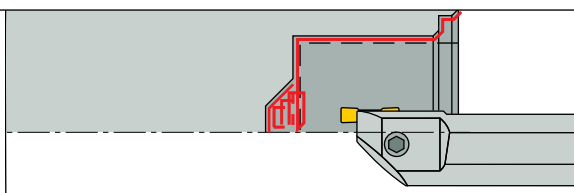

The Multifunction Advantage

This part was machined using three different conventional tools.

1 A standard ISO tool for external turning.

2 A boring bar for face turning and chamfering.

3 A face grooving tool for grooving, recessing and chamfering.

The **HELIFACE** Solution
A single integral **HELIFACE** tool **HFHPL-M** replaces three ISO tools and reduces machining time by 50%.

Insert Replacement

EDG 33B



Eccentric Extractor

Simple to operate; controlled rotation requires low force; guarantees limited upper jaw movement and secures maximum load on blade.
Two extractor pins are placed in the two holes in the holder blades.

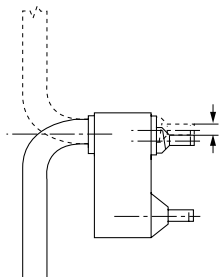

Indexing

- Place the **EDG** extractor in the holes
1. Hold the extractor against the tool.
 2. Rotate the eccentric handle to lift the upper jaw.

1

2

Machining Conditions in Face Grooving

Recommended feed range for grooving with HFPR/L inserts in various widths.

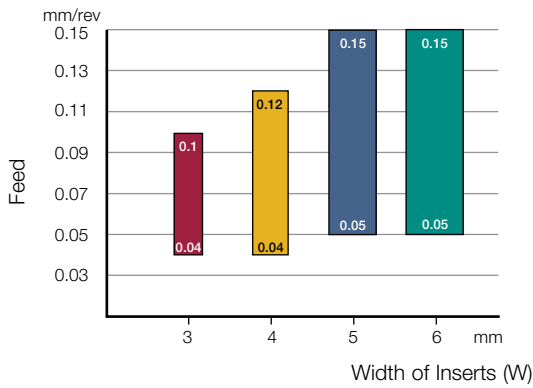

Chip shapes for grooving, according to width of insert and feed, using HFHR/L toolholders.

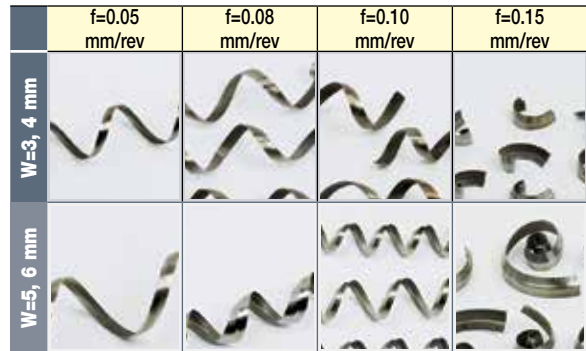

Note: In face grooving, narrowed and deformed chips are preferred. Curled and long chips can flow out more easily from deep grooves.

Recommended depth of cut and feed range for face turning using HFHR/L toolholders carrying HFPR/L inserts in various widths.

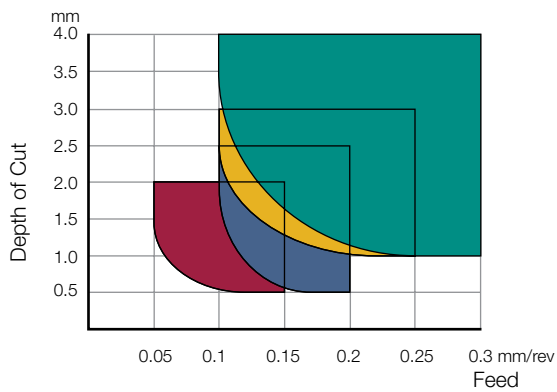

Chip shapes in face turning with inserts HFPR/L-5004 & HFPR/L 6004 and HFHR/L toolholders.

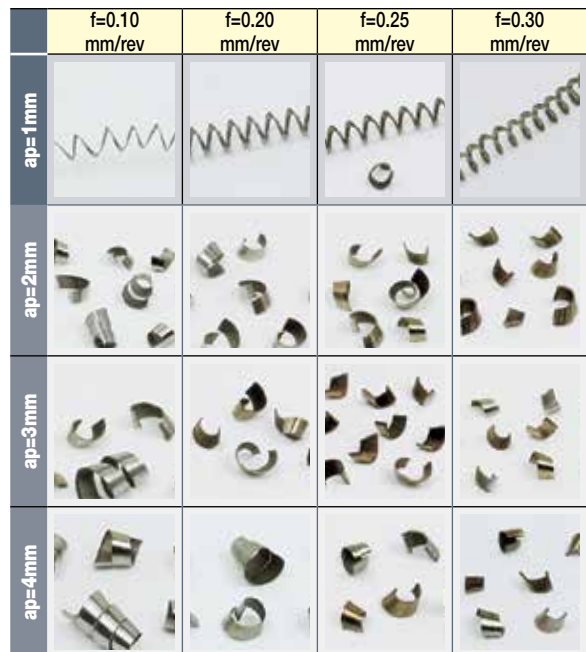

Note: In roughing, increase feed at small depth of cut and reduce feed at large depth of cut.

Face Grooving and Turning Recommendations Using Adapters for 3 mm Inserts

Recommended feed range for grooving with Grip 3... and **HGPL 3...** inserts and **HGAIR/L** and **HGAER/L** adapters. Feed range changes according to adapter type.

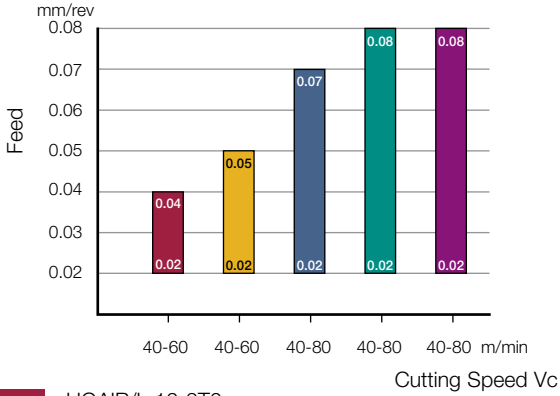

- HGAIR/L 12-3T6
- HGAER/L 12-3T6
- HGAIR/L 14-3T7
- HGAER/L 14-3T7
- HGAIR/L 17-3T8
- HGAER/L 17-3T8
- HGAIR/L 21-3T9
- HGAER/L 21-3T9
- HGAIR/L 25-3T9

Recommended depth of cut and feed range for turning with **HGPL 3...** inserts with **HGAIR/L** and **HGAER/L** adapters. Feed range changes according to adapter type.

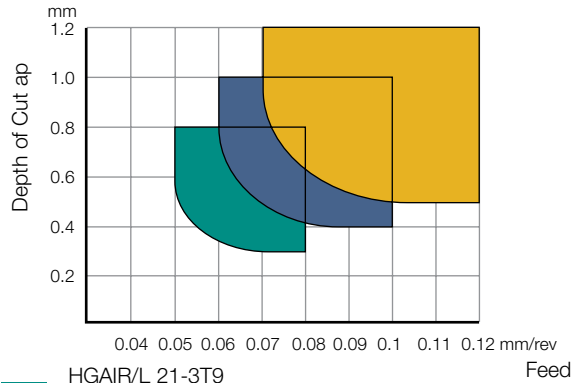

- HGAIR/L 21-3T9
- HGAER/L 21-3T9
- HGAIR/L 25-3T9
- HGAER/L 14-3T7
- HGAER/L 14-3T7
- HGAIR/L 17-3T8
- HGAER/L 17-3T8
- HGAIR/L 12-3T6
- HGAER/L 12-3T6

Note: In roughing, increase feed at small depth of cut, and reduce feed at large depth of cut.

Face Grooving and Turning Recommendations Using Adapters for 4-6 mm Inserts

Recommended feed range in grooving with **HFPR/L** inserts and **HFAIR/L** & **HFAER/L** adapters.

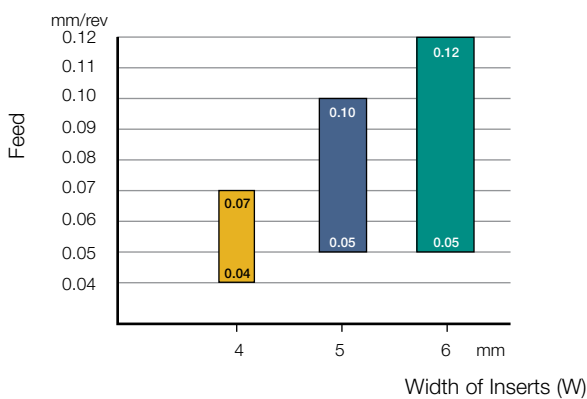

Recommended depth of cut and feed range in turning with **HFPR/L** inserts and **HFAIR/L** & **HFAER/L** adapters. Feed range changes according to adapter type.

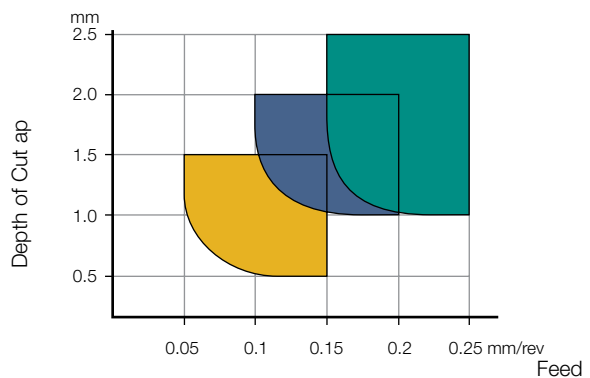

- HFAIR/L- ...4
- HFAER/L- ...4
- HFAIR/L- ...5
- HFAER/L- ...5
- HFAIR/L- ...6
- HFAER/L- ...6

Note: In roughing, reduce feed when depth of cut is increased, and increase feed at small depth of cut.

Specially Tailored

Semi-Standard Face Grooving and Undercutting Tools

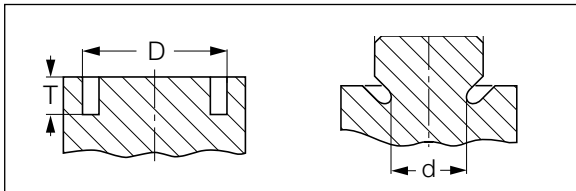

The following drawings show typical semi-standard face grooving tools that can be ordered. Please specify all relevant dimensions and attach workpiece material geometric details.

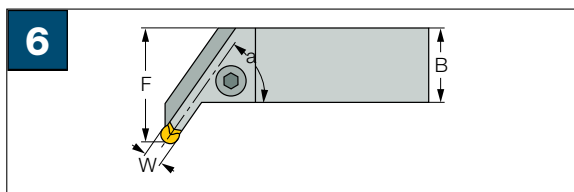
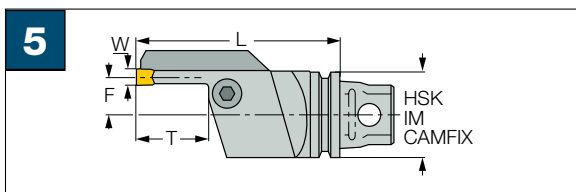
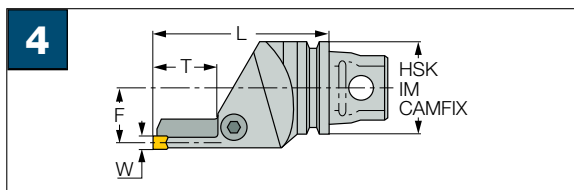
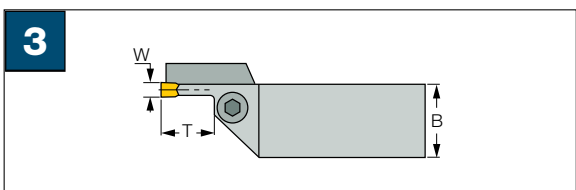
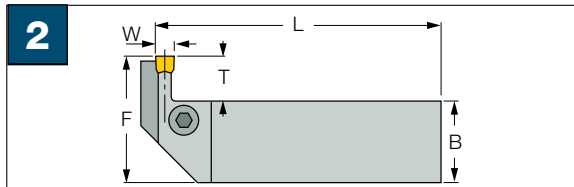
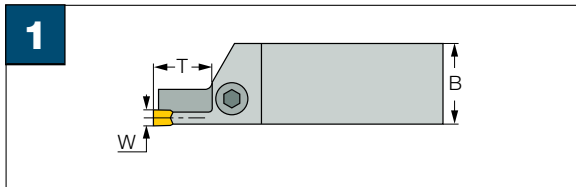

Grade Selection for Facing Applications

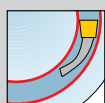
Material groups	ISO P		ISO M	ISO K	ISO N	ISO S	ISO H	
	1-11 Steel	12-13 Stainless Steel Ferritic & Martensitic	14 Stainless Steel Austenitic & Duplex (Ferritic- Austenitic)	15-20 Cast Iron	21-28 Non-ferrous	31-37 High Temperature Alloys	38-41 Hard Steel & Cast Iron	
 <p>FACING</p>	<p>Harder</p> <p>↑</p> <p>↓</p> <p>Tougher</p>	IC808	IC808	IC808	IC5010		IC808	
		IC8250	IC8250	IC8250		IC20	IC20	
		IC830	IC830		IC428	IC08	IC808	IC908

■ First choice

TOOL BLOCKS



TOOL BLOCKS

SGTBU/SGTBN

Blocks for Various Parting and Grooving Blades

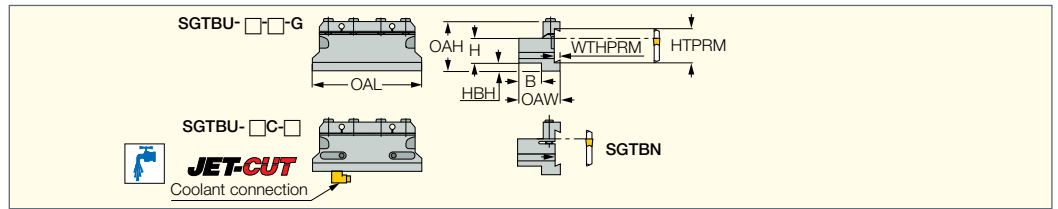

Designation	H	B	HTPRM	OAW	OAH	HBH	WTHPRM	OAL
SGTBN 16-2	16.0	16.0	19.0	26.00	30.0	4.0	2.00	76.00
SGTBU 16-5G	16.0	17.0	26.0	34.00	43.0	13.0	4.00	86.00
SGTBU 20-5G	20.0	21.0	26.0	38.00	43.0	9.0	4.00	86.00
SGTBU 20-6G	20.0	19.0	32.0	38.00	50.0	13.0	5.30	100.00
SGTBU 25-5G	25.0	23.0	26.0	43.00	45.0	5.0	4.00	110.00
SGTBU 25-6G	25.0	23.0	32.0	42.00	50.0	8.0	5.30	110.00
SGTBU 25-8M	25.0	23.0	45.0	42.00	70.0	27.0	5.30	110.00
SGTBU 25C-6 (1)	25.0	23.0	32.0	42.00	50.0	8.0	5.30	110.00
SGTBU 32-25-6G	32.0	25.0	32.0	44.00	54.0	5.0	5.30	110.00
SGTBU 32-6G	32.0	29.0	32.0	48.00	54.0	5.0	5.30	110.00
SGTBU 32-8M	32.0	29.0	45.0	48.00	70.0	20.0	5.30	110.00
SGTBU 32C-14 (1)	32.0	28.0	52.6	62.90	99.8	41.7	12.65	140.00
SGTBU 40-6G	40.0	-	32.0	60.00	57.0	-	5.30	114.00
SGTBU 40-9	40.0	41.0	52.6	66.00	81.0	22.0	8.00	130.00
SGTBU 40C-14 (1)	40.0	28.0	52.6	62.90	99.8	33.8	12.65	140.00
SGTBU 50-9	50.0	41.0	52.6	66.00	83.0	14.0	8.00	135.00
SGTBU 50C-14 (1)	50.0	28.0	52.6	62.90	99.8	23.8	12.65	140.00
SGTBU 100-9-12	50.0	49.0	100.0	108.00	155.0	73.5	15.00	225.00
SGTBU 150-9-12	50.0	49.0	150.0	111.00	209.0	127.5	15.00	306.00

• Choose blade by HTPRM dimension

(1) Elbow-style connector unit supplied with each JET-CUT tool block

For tools, see pages: Anti-Vibration Blades (268) • CGFG 51-P8 (563) • CGHN-8-10D (270) • CGHN-D (266) • CGHN-DG (267) • CGHN-P8 (267) • CGHR/L-12-14D (319) • CGHR/L-P8DG (267) • DGFH (252) • DGFHR/L (426) • DGFHR/L-B-D..(R/L) (428) • HFFA (546) • HFFH (546) • HFFR/L-T (550) • HGFH (251) • PCHBR/L (302) • SGFFA (569) • SGFFH (569) • TGFH/R/L (318) • TGFHL-TR (462) • TGFHR/L (452) • TGHN-D (256) • TNFFA-IQ (566) • TNFFH-IQ (566)

SGTBU 100/150-9-12

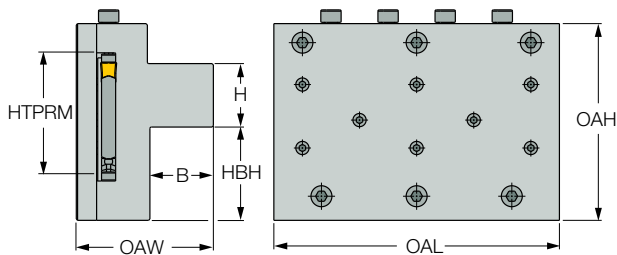

Spare Parts

Designation										
SGTBN 16-2		SR M5X25 DIN912		HW 4.0						
SGTBU 16-5G	BKU 86	SR M6X16 DIN912		HW 5.0						
SGTBU 20-5G	BKU 86	SR M6X16 DIN912		HW 5.0						
SGTBU 20-6G	BKU 100	SR M6X16 DIN912		HW 5.0						
SGTBU 25-5G	BKU 105	SR M6X16 DIN912		HW 5.0						
SGTBU 25-6G	BKU 110	SR M6X16 DIN912		HW 5.0						
SGTBU 25-8M	BKU 110	SR M6X16 DIN912	SR M6X30 DIN912	HW 5.0						
SGTBU 25C-6	BKU 110	SR M6X16 DIN912	SR M6X25 DIN912	HW 5.0			SGCU 344	CF 343*	CGF 343*	CGM 343*
SGTBU 32-25-6G	BKU 110	SR M6X16 DIN912	SR M6X30 DIN912	HW 5.0						
SGTBU 32-6G	BKU 110	SR M6X16 DIN912		HW 5.0						
SGTBU 32-8M	BKU 110	SR M6X16 DIN912		HW 5.0						
SGTBU 32C-14	BKU 32-14	SR M10X30 DIN912		HW 8.0	JHP ELBOW 90-G1/8-7/16UNF	OR 34X2.5N				
SGTBU 40-6G	BKU 110	SR M6X25 DIN912		HW 5.0						
SGTBU 40-9	BK 509	SR M8X25DIN912		HW 6.0						
SGTBU 40C-14	BKU 32-14	SR M10X30 DIN912		HW 8.0	JHP ELBOW 90-G1/8-7/16UNF	OR 34X2.5N				
SGTBU 50-9	BK 509	SR M8X30DIN912		HW 6.0						
SGTBU 50C-14	BKU 32-14	SR M10X30 DIN912		HW 8.0	JHP ELBOW 90-G1/8-7/16UNF	OR 34X2.5N				
SGTBU 100-9-12		SR M10X25 DIN912		HW 8.0						
SGTBU 150-9-12		SR M10X25 DIN912		HW 8.0						

* Optional, should be ordered separately

TOOL BLOCKS

SGTBK

Blocks for Heavy Duty Parting and Grooving Blades

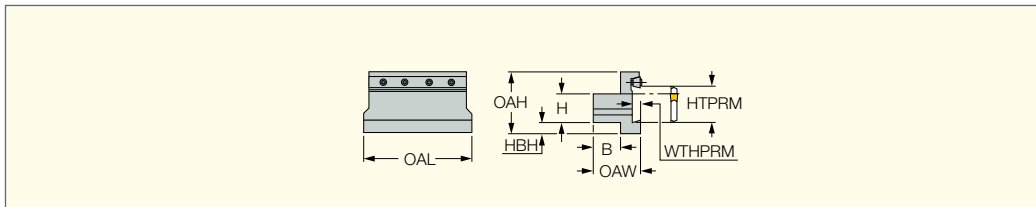

Designation	H	B	WTHPRM	HTPRM	OAW	OAH	HBH	OAL			
SGTBK 32-9	32.0	28.0	8.50	32.0	48.00	62.0	3.0	120.00	BK 32-9 WEDG	SR M6X16 DIN912	HW 5.0
SGTBK 38-9	38.0	35.0	8.50	52.6	60.00	90.0	25.0	135.00	BK 40-9	SR M6X20 DIN912	HW 5.0
SGTBK 40-9	40.0	35.0	8.50	52.6	60.00	90.0	23.0	135.00	BK 40-9	SR M6X20 DIN912	HW 5.0
SGTBK 50-9	50.0	40.0	8.50	52.6	65.00	90.0	15.0	135.00	BK 40-9	SR M6X20 DIN912	HW 5.0

• Choose blade by HTPRM dimension

For tools, see pages: Anti-Vibration Blades (268) • CGFG 51-P8 (563) • CGHN-8-10D (270) • CGHN-P8 (267) • CGHR/L-12-14D (319) • CGHR/L-P8DG (267) • DGFH (252) • HFFH (546) • PCHBR/L (302) • SGFFH (569) • TGFH/R/L (318) • TGFHR/L (452) • TNFFH-IQ (566)

TOOL BLOCKS

SGTBR/L

Blocks for Parting and Grooving Blades for Conventional Lathes

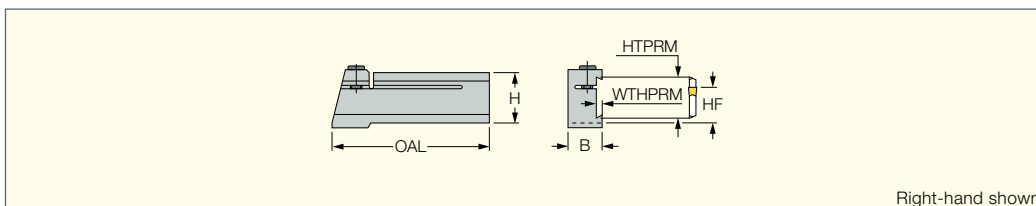

Right-hand shown

Designation	H	HF	HTPRM	B	OAL	WTHPRM		
SGTBR 19-2	25.0	19.0	19.0	19.0	100.00	2.00	SR M6X25 DIN912	HW 5.0
SGTBR/L 25-6	32.0	25.0	26.0	20.0	121.50	5.00	SR M6X25 DIN912	HW 5.0

• Choose blade by HTPRM dimension

For tools, see pages: DGFH (252) • DGFHR/L (426) • DGFHR/L-B-D..(R/L) (428) • HGFH (251) • PCHBR/L (302) • TGFH/R/L (318) • TGFHL-TR (462) • TGFHR/L (452)

TOOL BLOCKS

UBHCR/L

Holders for Grooving, Turning and Parting Blades

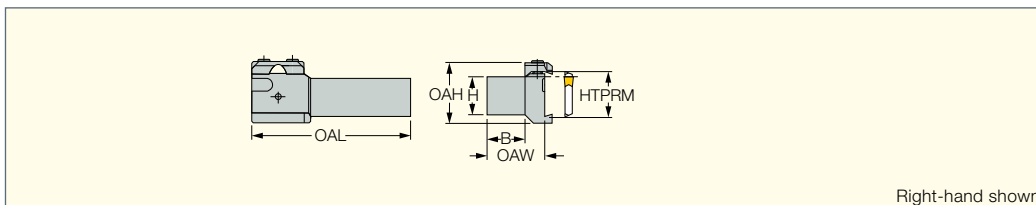

Right-hand shown

Designation	H	HTPRM	B	OAH	OAW	OAL				
UBHCR/L 20-26	20.0	26.0	20.0	42.0	35.60	100.00	BKU 176 307	SR M6X16 DIN912	HW 5.0	SPRING PLUNGER M6X14X3.5
UBHCR/L 25-32	25.0	32.0	25.0	46.0	40.00	130.00	BKU 176 307	SR M6X16 DIN912	HW 5.0	SPRING PLUNGER M6X14X3.5
UBHCR/L 32-32	32.0	32.0	32.0	46.0	47.00	130.00	BKU 176 307	SR M6X16 DIN912	HW 5.0	SPRING PLUNGER M6X14X3.5

• Choose blade by HTPRM dimension

For tools, see pages: CGHN-D (266) • CGHN-DG (267) • CGHN-S (266) • CGHR/L-P8DG (267) • DGFH (252) • DGFHR/L (426) • DGFHR/L-B-D..(R/L) (428) • HFFA (546) • HFFH (546) • HFFR/L-T (550) • HGFH (251) • SGFFA (569) • SGFFH (569) • TGFH/R/L (318) • TGFHL-TR (462) • TGFHR/L (452) • TGHN-D (256) • TGHN-S (257) • TNFFA-IQ (566) • TNFFH-IQ (566)

TOOL BLOCKS

SGTBF

Perpendicular Blocks for Parting and Grooving Blades

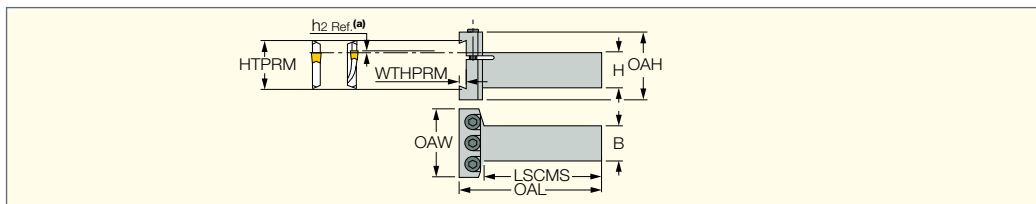

Designation	H	B	HTPRM	OAL	LSCMS	OAW	OAH	WTHPRM		
SGTBF 25-A	25.0	25.0	32.0	102.00	80.00	48.00	48.0	5.50	SR M6X40 DIN912	HW 5.0
SGTBF 32-A	32.0	32.0	32.0	116.00	100.00	48.00	48.0	5.50	SR M6X40 DIN912	HW 5.0

• (a) h2 Ref. as defined for SELF-GRIP face grooving blades • Choose blade by HTPRM dimension • Choose blade by HTPRM dimension

For tools, see pages: DGFH (252) • DGFHR/L (426) • DGFHR/L-B-D..(R/L) (428) • HFFH (546) • HFFR/L-T (550) • HGFH (251) • SGFFA (569) • SGFFH (569) • TGFH/R/L (318) • TGFHR/L (452) • TNFFA-IQ (566) • TNFFH-IQ (566)

JETCUT Assembly

SELF-GRIP

- C** Insert GF□
- D** Blade SGFH□K-□
- E** Cap **SGC 340** supplied with blade; to be used with Option 1 only.
- F** Tool block **SGTBU□C-□**
- G** Elbow-style connector unit supplied with each tool block; **SGCU-344**
- H** 3/16" copper Tube 343 (length 250 mm)
- I** Choice of connector sets:
CGM-343 (G 1/8 external thread)
CGF-343 (G 1/8 internal thread)
CF-343 (NPT 1/8 internal thread)
- J** Standard current tool block **SGTBN, SGTBU, SGTBF**
- K** Coolant connection unit; **SGCU-341**
- M** Integral shank holder **SGTFR/L□K-□**

Option 1:
Coolant supplied through the tool block.

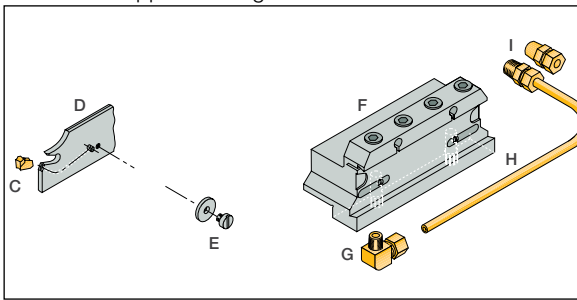

Option 2:
Coolant supplied directly to the blade.

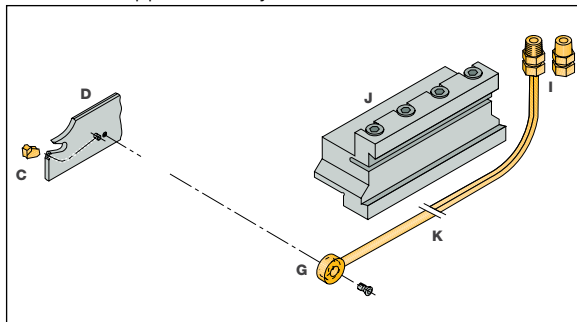

Option 3:
Coolant supplied directly to the integral shank tool.

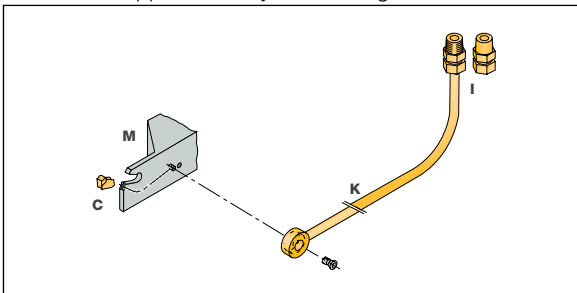

DO-GRIP
500 STRAIGHT LINE

The coolant supply tube can be attached directly to the **DGTR...C** integral tool, **DGFH-C** blades used on the regular blocks or to the **SGTBU-C** blocks which have coolant passages and connecting ports.

The Right Connection for Your Application

Option 1:
Coolant supplied directly to the blade.

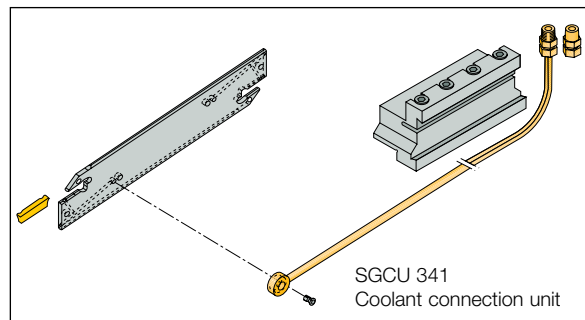

- Connectors:
CGM 343 (G1/8 external thread)
CGF 343 (G1/8 internal thread)
CF 343 (NPT1/8 internal thread)

Option 2:
Coolant supplied through the tool block.

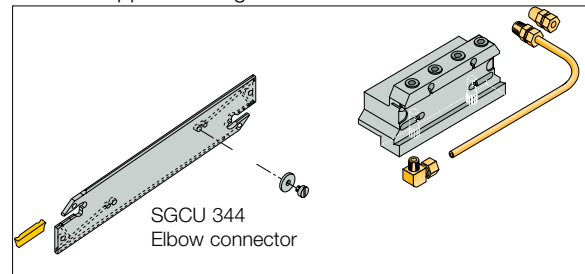

- TUBE 343**
 3/16" copper tube (length 250 mm)
 (G1/8 external thread) (G1/8 internal thread) (NPT1/8 external thread) (NPT1/8 internal thread)

Option 3:
Coolant supplied directly to the tool.

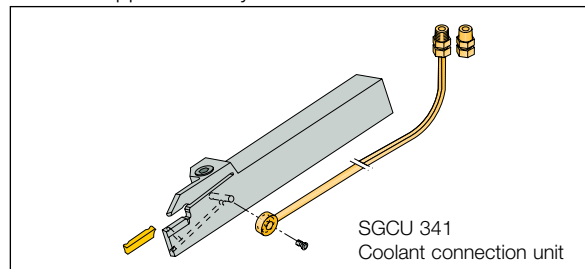

- Connectors:
CGM 343 (G1/8 external thread)
CGF 343 (G1/8 internal thread)
CF 343 (NPT1/8 internal thread)

EXCHANGEABLE HEADS



TABLE OF CONTENTS

CAMFIX (ISO 26623-1)	590
HSK-T (ISO 12164-3 T Type and ICTM Standard)	596
IM (ISO 26622-1 and Mazak XMZ Standard).....	598

ISCAR offers a wide range of tools for three types of Quick-Change systems:

1. **CAMFIX (ISO 26623-1)**
2. **HSK-T (ISO 12164-3 T Type and ICTM Standards)**
3. **IM (ISO 26622-1 and Mazak XMZ Standards)**

CAMFIX (ISO 266231)



Quick Change tools are expensive compared to standard shank tools. ISCAR offers economical solutions by using adapters, blades or regular tools and boring bars on the Quick Change adaptations.

HSK-T (ISO 1264-3 T Type and ICTM Standard)



CAMFIX

CAMFIX ISO 26623-1
Toolholder Standard

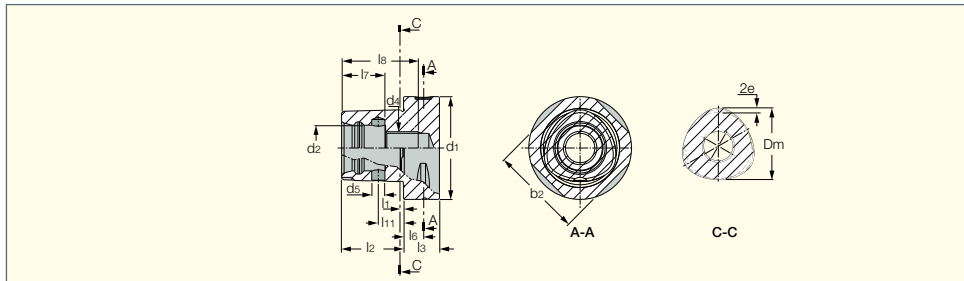

CAMFIX	b ₂	d ₁ ±0.1	d ₂	d ₄	d ₅ ±0.1	D _m	e	l ₁	l ₂ ±0.1	l ₃ min	l ₆ ±0.15	l ₇ ±0.15	l ₈ min	l ₁₁ ±0.1
C3	28,3	32	15	M12x1.5	3,6	22	0,7	2,5	19	15	6	13	25	8
C4	35,3	40	18	M14x1.5	4,6	28	0,9	2,5	24	20	8	15	30	11,5
C5	44,4	50	21	M16x1.5	6,1	35	1,12	3	30	20	10	20	37	14
C6	55,8	63	28	M20x2	8,1	44	1,4	3	38	22	12	27	47	15,5
C8	71,1	80	32	M20x2	9,1	55	2	3	48	30	12	28	48	25
C8X	88,7	100	32	M20x2	9,1	55	2	3	48	32	16	28	48	25
C10	88,3	100	43	M24x2	12	72	2,8	3	60	36	16	40	70	26,5

CAMFIX - ISO 26623-1 Standard Quick Change Shanks

Features

- **Symmetrical design:** Due to the symmetrical design, the torque load is distributed on the polygon, providing a self-centering effect.
- **Rigidity:** The CAMFIX clamping mechanism is extremely rigid against bending forces.
- **Accuracy:** The taper and face contact ensure high repeatability within 2 microns when operated with an automatic tool changer.

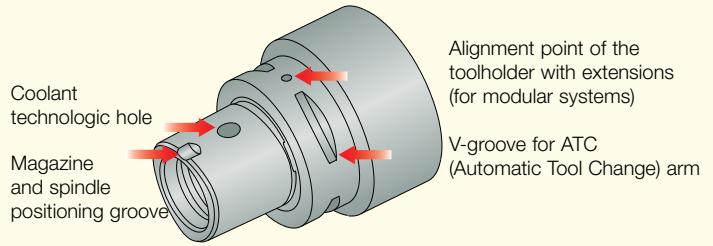

TOOL BLOCKS

CAMFIX

C#-TBK-R/L
Blocks with CAMFIX
Exchangeable Shanks for Parting and Grooving Blades

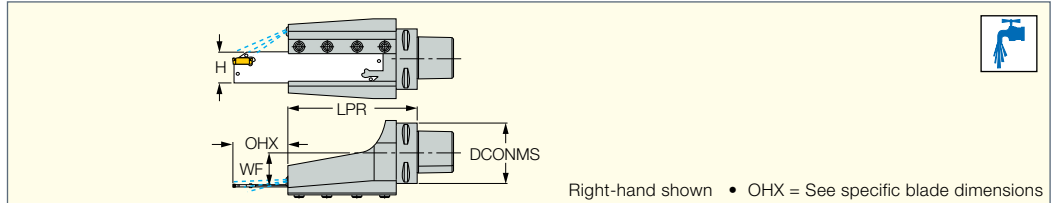

Right-hand shown • OHX = See specific blade dimensions

Designation	DCONMS	WF	LPR	H				
C6 TBK-32R/L	63.00	32.0	138.00	32.0	BK 32-9 WEDG	SR M6X16 DIN912	HW 5.0	EZ 125
C8 TBK-32R	80.00	40.5	147.00	32.0	BK 32-9 WEDG	SR M6X16 DIN912	HW 5.0	EZ 125
C8 TBK-52R	80.00	40.5	161.00	52.0	BK 40-9	SR M6X16 DIN912	HW 5.0	EZ 125

For tools, see pages: CGHN-DG (267) • CGHR/L-P8DG (267) • DGFH (252) • DGFHR/L (426) • DGFHR/L-B-D..(R/L) (428) • HFFH (546) • HGFH (251) • PCHBR/L (302) • TGFH/R/L (318) • TGFHR/L (452) • TNFFH-IQ (566)

TOOL BLOCKS

CAMFIX

C#-TBU
Blocks with CAMFIX
Exchangeable Tapered Shanks for Parting and Grooving Blades

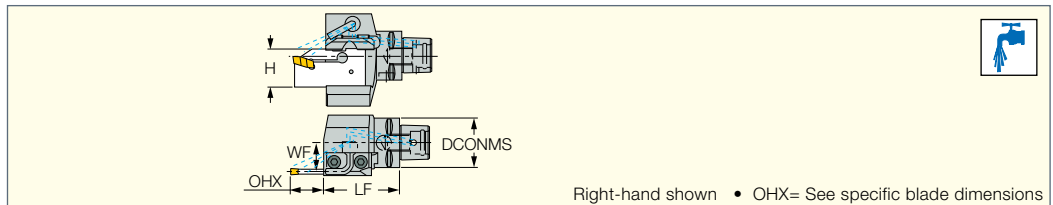

Right-hand shown • OHX= See specific blade dimensions

Designation	DCONMS	WF	LF	H					
C4 TBU-32R/L	40.00	21.0	60.00	32.0	BKU 176 307	SR M6X25 DIN912	HW 5.0	SR M6X8 DIN916	EZP 5
C5 TBU-32R/L	50.00	30.0	64.00	32.0	BKU 176 307	SR M6X25 DIN912	HW 5.0	SR M6X8 DIN916	EZP 5

For tools, see pages: CGHN-S (266) • TGHN-S (257)

MODULARGRIP

CAMFIX

C#-MAHDR-45
Holders with CAMFIX
Exchangeable Shanks for Parting, Grooving, Turning and Facing Adapters

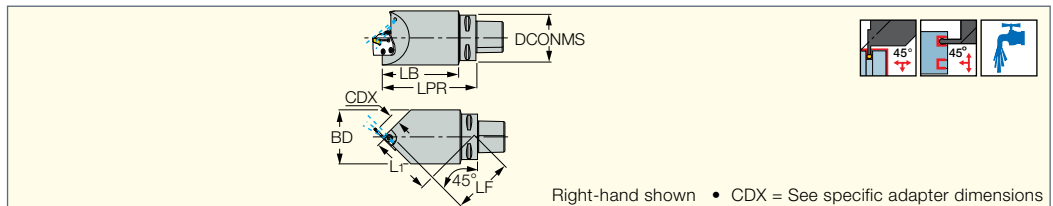

Right-hand shown • CDX = See specific adapter dimensions

Designation	DCONMS	LPR	L ₁	LB	LF	BD
C6 MAHDR-45	63.00	130.00	91.9	105.78	89.0	75.00
C8 MAHDR-45	80.00	130.00	91.9	-	89.0	80.00

• For mill-turn machines

For tools, see pages: CGPAD (265) • DGAD-B-D (436) • DGAD/HGAD (436) • HFPAD-3 (549) • HFPAD-4 (549) • HFPAD-5 (550) • HFPAD-6 (550) • HGPAD (251) • PCADR/L (300) • SCLCR-PAD (50) • SDJCR-PAD (54) • SVJCR-PAD (60) • SWAPR-PAD (66) • TGAD (455) • TGPAD (256) • TTADR/L-JHP (651)



Spare Parts

Designation								
C6 MAHDR-45	SR M5-04451	T-20/5	SR 14-519 ^(a)	SR M6X20DIN7984	HW 4.0	SR M6X6DIN551 14H/22H ^(c)	SR M5X4 DIN913	EZ 83
C8 MAHDR-45	SR M5-04451	T-20/5	SR 14-519 ^(a)	SR M6X20-XT ^(b)	HW 5.0	SR M6X6DIN551 14H/22H ^(c)	SR M5X6 DIN913	EZ 83

^(a) For DGAD, HGAD and PCADR/L adapters; supplied in the attached plastic bag

^(b) For CGPAD, HGPAD, TGPAD and HFPAD adapters; supplied with the tools

^(c) Used to prevent chips from entering the upper locking screw hole

MODULARGRIP

CAMFIX

C#-MAHDOR

Holders with CAMFIX
Exchangeable Shanks for
Parting, Grooving, Turning
and Facing Adapters

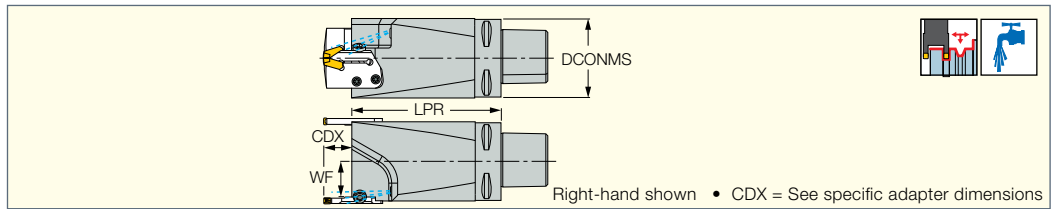

Designation	DCONMS	WF	LPR							
C6 MAHDOR	63.00	29.0	130.00	SR M5-04451	T-20/5	SR 14-519(a)	SR M6X20-XT(b)	HW 5.0	SR M6X6DIN551 14H/22H(c)	EZ 125
C8 MAHDOR	80.00	37.5	130.00	SR M5-04451	T-20/5	SR 14-519(a)	SR M6X20-XT(b)	HW 5.0	SR M6X6DIN551 14H/22H(c)	EZ 125

(a) For DGAD, HGAD and PCADR/L adapters; supplied in the attached plastic bag

(b) For CGPAD, HGPAD, TGPAD and HFPAD adapters; supplied with the tools

(c) Used to prevent chips from entering the upper locking screw hole

For tools, see pages: DGAD-B-D (436) • DGAD/HGAD (436) • HFPAD-3 (549) • HFPAD-4 (549) • HFPAD-5 (550) • HFPAD-6 (550) • HGPAD (251) • SCLCR-PAD (50) • SDJCR-PAD (54) • SVJCR-PAD (60) • SWAPR-PAD (66) • TTADR/L-JHP (651)

MODULARGRIP

CAMFIX

C#-MAHUR/L

Holders with CAMFIX Shanks
for 10° Mounting on Mill-Turn
Machines for Parting, Grooving,
Turning and Facing Adapters

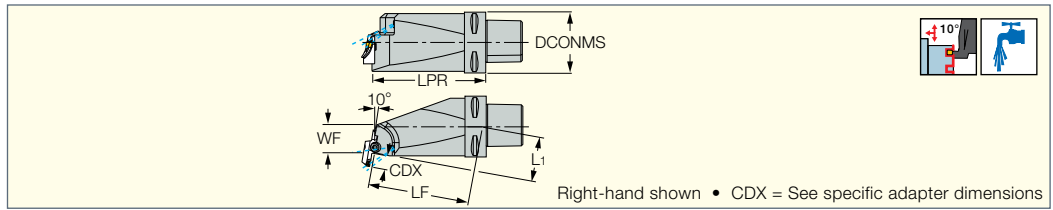

Designation	DCONMS	LF	WF	LPR	L1
C6 MAHUR/L-10	63.00	113.1	29.00	123.00	49.4

For tools, see pages: CGPAD (265) • DGAD-B-D (436) • DGAD/HGAD (436) • HFPAD-3 (549) • HFPAD-4 (549) • HFPAD-5 (550) • HFPAD-6 (550) • HGPAD (251) • PCADR/L (300) • SCLCR-PAD (50) • SDJCR-PAD (54) • SVJCR-PAD (60) • SWAPR-PAD (66) • TGAD (455) • TGPAD (256) • TTADR/L-JHP (651)

Spare Parts

Designation							
C6 MAHUR/L-10	SR M5-04451	T-20/5	SR 14-519(a)	SR M6X20-XT(b)	HW 5.0	SR M6X6DIN551 14H/22H(c)	EZ 125

(a) For DGAD, HGAD and PCADR/L adapters; supplied in the attached plastic bag

(b) For CGPAD, HGPAD, TGPAD and HFPAD adapters; supplied with the tools

(c) Used to prevent chips from entering the upper locking screw hole

MODULARGRIP

CAMFIX

C#-MAHD

Holders with CAMFIX
Exchangeable Shanks for
Parting, Grooving, Turning
and Facing Adapters

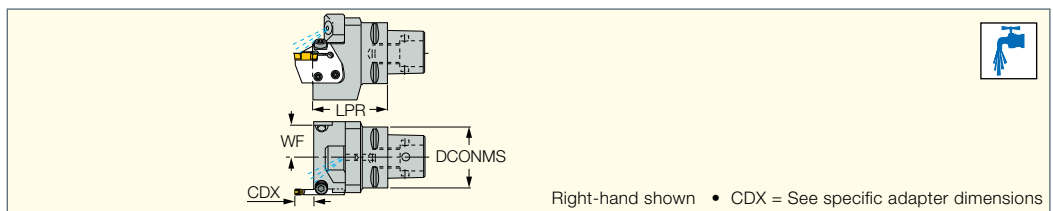

Designation	DCONMS	LPR	WF
C3 MAHD	32.00	50.00	18.5
C4 MAHD	40.00	46.50	22.1
C5 MAHD	50.00	47.00	23.0
C6 MAHD	63.00	50.00	29.0
C8 MAHD	80.00	60.00	37.5

For tools, see pages: CGPAD (265) • DGAD-B-D (436) • DGAD/HGAD (436) • HFPAD-3 (549) • HFPAD-4 (549) • HFPAD-5 (550) • HFPAD-6 (550) • HGPAD (251) • PCADR/L (300) • SCLCR-PAD (50) • SDJCR-PAD (54) • SVJCR-PAD (60) • SWAPR-PAD (66) • TGAD (455) • TGPAD (256) • TTADR/L-JHP (651)

Spare Parts

Designation									
C#-MAHD	SR M5-04451	T-20/5	SR 14-519(a)	SR M6X20-XT(b)	HW 5.0	SR M6X6DIN551 14H/22H(c)	EZ 125	EZA 125	SR 76-1022

(a) For DGAD, HGAD and PCADR/L adapters; supplied in the attached plastic bag

(b) For CGPAD, HGPAD, TGPAD and HFPAD adapters; supplied with the tools

(c) Used to prevent chips from entering the upper locking screw hole

MODULAR-GRIP
JETCUT CAMFIX

C#-MAHD-JHP
Holders with CAMFIX
Exchangeable Shanks and High
Pressure Coolant Channels for
MODULAR-GRIP Adapters

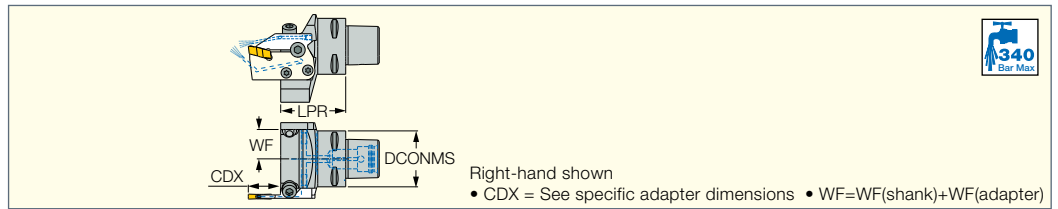

Right-hand shown
• CDX = See specific adapter dimensions • WF=WF(shank)+WF(adapter)

Designation	DCONMS	LPR	WF							
C3 MAHD-JHP	32.00	45.00	18.5	SR M5-04451	T-20/5	SR M6X12DIN6912	SR M6X20-XT	HW 5.0	OR 5X1N	SR M4X8ISO14580 BLACK
C4 MAHD-JHP	40.00	46.50	21.0	SR M5-04451	T-20/5	SR M6X12DIN6912	SR M6X20-XT	HW 5.0	OR 5X1N	SR M4X8ISO14580 BLACK
C5 MAHD-JHP	50.00	47.00	26.0	SR M5-04451	T-20/5	SR M6X12DIN6912	SR M6X20-XT	HW 5.0	OR 5X1N	SR M4X8ISO14580 BLACK
C6 MAHD-JHP	63.00	50.00	32.5	SR M5-04451	T-20/5	SR M6X12DIN6912	SR M6X20-XT	HW 5.0	OR 5X1N	SR M4X8ISO14580 BLACK

For tools, see pages: CGPAD (265) • CGPAD-JHP (265) • DGAD-B-D (436) • DGAD/HGAD (436) • DGPAD-JHP (437) • HFPAD-3 (549) • HFPAD-4 (549) • HFPAD-5 (550) • HFPAD-6 (550) • HGPAD (251) • HGPAD-JHP (251) • PCADR/L (300) • PCADR/L-JHP (301) • SCLCR-PAD (50) • SDJCR-PAD (54) • SVJCR-PAD (60) • SWAPR-PAD (66) • TAGPAD-JHP (456) • TGAD (455) • TGPAD (256) • TGPAD-JHP (256) • TTADR/L-JHP (651)

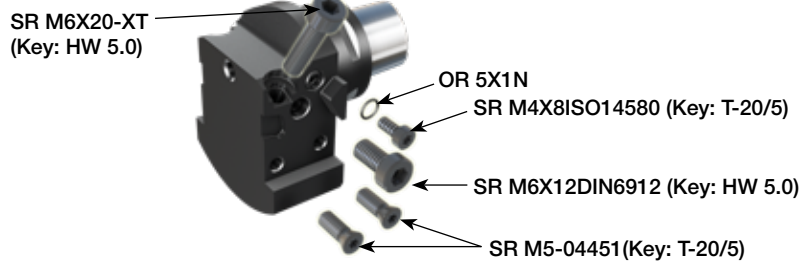

MODULAR-GRIP
CAMFIX

C#-MAHPD
Perpendicular Holders with
CAMFIX Exchangeable Shanks
Carrying Adapters for Parting,
Grooving, Turning and Facing

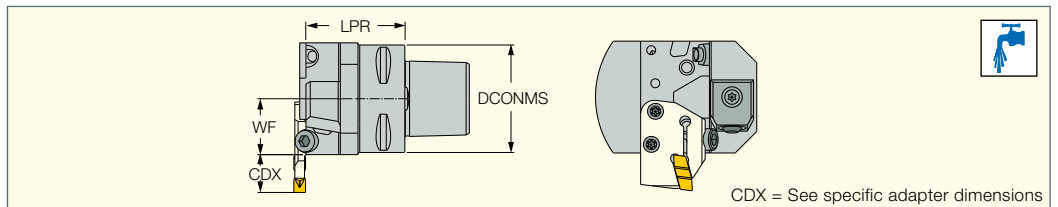

CDX = See specific adapter dimensions

Designation	DCONMS	LPR	WF
C4 MAHPD	40.00	46.00	25.00
C5 MAHPD	50.00	46.00	26.00
C6 MAHPD	63.00	47.00	33.00
C8 MAHPD	80.00	56.00	42.00

For tools, see pages: CGPAD (265) • DGAD-B-D (436) • DGAD/HGAD (436) • HFPAD-3 (549) • HFPAD-4 (549) • HFPAD-5 (550) • HFPAD-6 (550) • HGPAD (251) • PCADR/L (300) • SCLCR-PAD (50) • SDJCR-PAD (54) • SVJCR-PAD (60) • SWAPR-PAD (66) • TGAD (455) • TGPAD (256) • TTADR/L-JHP (651)

Spare Parts

Designation										
C4 MAHPD	SR M5-04451	T-20/5	SR 14-519 ^(a)	SR M6X20-XT ^(b)	HW 5.0	SR M6X6DIN551 14H/22H ^(c)	EZ 125	SR 76-1022	EZA-21414	
C5 MAHPD	SR M5-04451	T-20/5	SR 14-519 ^(a)	SR M6X20-XT ^(b)	HW 5.0	SR M6X6DIN551 14H/22H ^(c)	EZ 125	SR 76-1022	EZA-21414	
C6 MAHPD	SR M5-04451	T-20/5	SR 14-519 ^(a)	SR M6X20-XT ^(b)	HW 5.0	SR M6X6DIN551 14H/22H ^(c)	EZ 125	SR 76-1022	EZA-21414	
C8 MAHPD	SR M5-04451	T-20/5	SR 14-519 ^(a)	SR M6X20-XT ^(b)	HW 5.0	SR M6X6DIN551 14H/22H ^(c)	EZ 125			EZP 5

(a) For DGAD, HGAD and PCADR/L adapters; supplied in the attached plastic bag

(b) For CGPAD, HGPAD, TGPAD and HFPAD adapters; supplied with the tools

(c) Used to prevent chips from entering the upper locking screw hole

MODULAR-GRIP
JETCUT CAMFIX

C#-MAHPD-JHP
Perpendicular Holders with
CAMFIX Exchangeable Shanks
for Parting, Grooving, Turning
and Facing Adapters

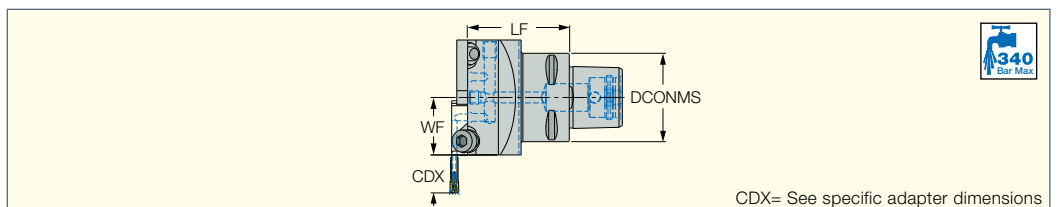

CDX= See specific adapter dimensions

Designation	DCONMS	LF	WF							
C3 MAHPD-JHP	32.00	40.00	26.00	SR M5-04451	T-20/5	SR M6X12DIN6912	SR M6X20-XT	HW 5.0	OR 5X1N	SR M4X8 ISO14580 BLACK
C4 MAHPD-JHP	40.00	46.00	26.00	SR M5-04451	T-20/5	SR M6X12DIN6912	SR M6X20-XT	HW 5.0	OR 5X1N	SR M4X8 ISO14580 BLACK
C5 MAHPD-JHP	50.00	46.00	26.00	SR M5-04451	T-20/5	SR M6X12DIN6912	SR M6X20-XT	HW 5.0	OR 5X1N	SR M4X8 ISO14580 BLACK
C6 MAHPD-JHP	63.00	46.00	33.00	SR M5-04451	T-20/5	SR M6X12DIN6912	SR M6X20-XT	HW 5.0	OR 5X1N	SR M4X8 ISO14580 BLACK

For tools, see pages: CGPAD (265) • CGPAD-JHP (265) • DGAD-B-D (436) • DGAD/HGAD (436) • DGPAD-JHP (437) • HFPAD-3 (549) • HFPAD-4 (549) • HFPAD-5 (550) • HFPAD-6 (550) • HGPAD (251) • HGPAD-JHP (251) • PCADR/L (300) • PCADR/L-JHP (301) • SCLCR-PAD (50) • SDJCR-PAD (54) • SVJCR-PAD (60) • SWAPR-PAD (66) • TAGPAD-JHP (456) • TGAD (455) • TGPAD (256) • TGPAD-JHP (256) • TTADR/L-JHP (651)

CUTGRIP CAMFIX

C#-GHAD-8

Holders for Grooving, Turning and Facing Adapters with CAMFIX Exchangeable Shanks

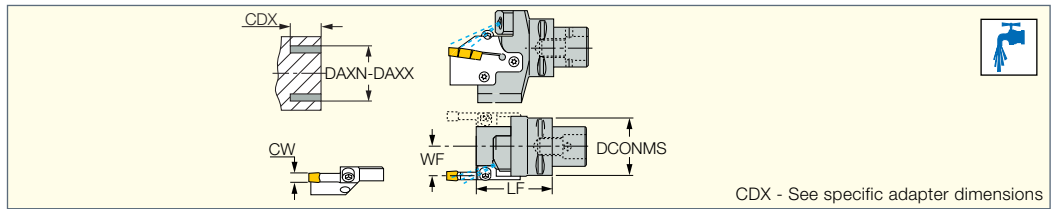

CDX - See specific adapter dimensions

Designation	DCONMS	LF	WF	CW	DAXN ⁽¹⁾	DAXX ⁽²⁾	CDX
C5 GHAD-8	50.00	65.00	26.00	8.00	80.0	510.0	25.00
C6 GHAD-8	63.00	65.00	32.50	8.00	80.0	510.0	25.00

⁽¹⁾ Minimum axial grooving diameter

⁽²⁾ Maximum axial grooving diameter

Spare Parts

Designation							
C#-GHAD-8	SR 14-519	T-20/5	SR M6X25 DIN912	HW 5.0	SR 76-1022	EZA 125	EZ 125

CUTGRIP JET CUT CAMFIX

C#-GHAD-JHP

Holders with High Pressure Coolant Channels and CAMFIX Exchangeable Shanks for Grooving and Turning

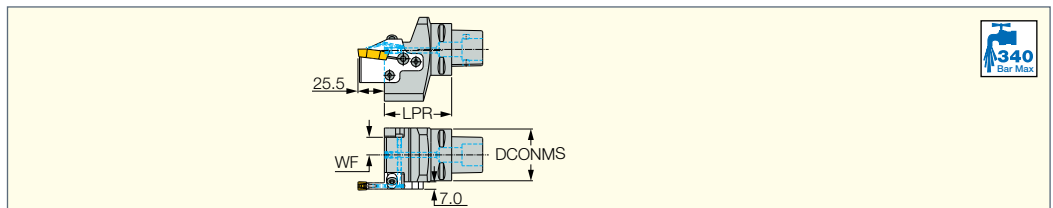

Designation	DCONMS	LPR	WF
C5 GHAD-8-JHP	50.00	65.00	17.00
C6 GHAD-8-JHP	63.00	65.00	23.50
C8 GHAD-8-JHP	80.00	74.00	38.50

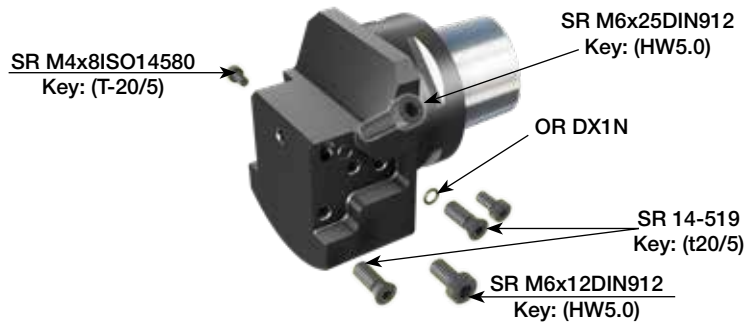

Spare Parts

Designation							
C5 GHAD-8-JHP	SR 14-519	T-20/5	SR M6X25 DIN912	HW 5.0	SR M6X12DIN6912	OR 5X1N	SR M4X8ISO14580 BLACK
C6 GHAD-8-JHP	SR 14-519	T-20/5	SR M6X25 DIN912	HW 5.0X120 MM	SR M6X12DIN6912	OR 5X1N	SR M4X8ISO14580 BLACK
C8 GHAD-8-JHP	SR 14-519	T-20/5	SR M6X25 DIN912	HW 5.0X120 MM	SR M6X12DIN6912	OR 5X1N	SR M4X8ISO14580 BLACK

CAMFIX

C#-GHAPR/L-8

Perpendicular Holders for Grooving, Turning and Facing Adapters with CAMFIX Exchangeable Shanks

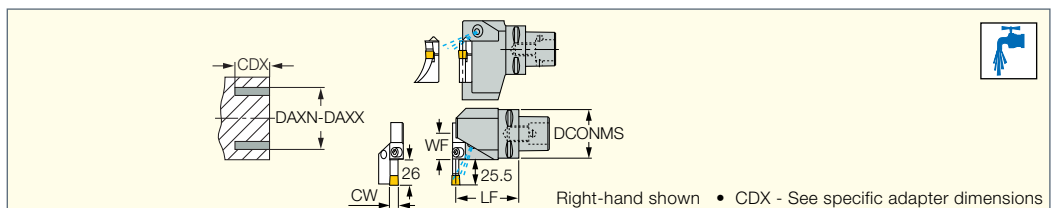

Right-hand shown • CDX - See specific adapter dimensions

Designation	DCONMS	LF	WF	CW	DAXN ⁽¹⁾	DAXX ⁽²⁾	CDX					
C5 GHAPR/L-8	50.00	64.00	26.00	8.00	80.0	510.0	25.00	SR 14-519	T-20/5	SR M6X25 DIN912	HW 5.0	EZ 125
C6 GHAPR/L-8	63.00	75.00	33.00	8.00	80.0	510.0	25.00	SR 14-519	T-20/5	SR M6X25 DIN912	HW 5.0	EZ 125

⁽¹⁾ Minimum axial grooving diameter

⁽²⁾ Maximum axial grooving diameter

CAMFIX

C#-HAD

Holders with CAMFIX Exchangeable Tapered Shanks for Internal Facing Adapters

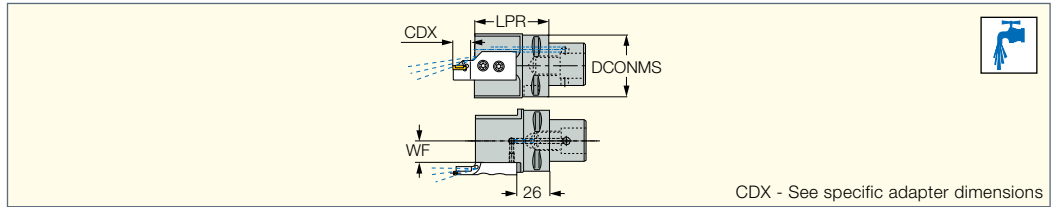

CDX - See specific adapter dimensions

Designation	DCONMS	LPR	WF				
C4 HAD	40.00	60.00	18.0	SR 14-519	T-20/3	SR M4X6DIN912	HW 3.0
C5 HAD	50.00	60.00	18.0	SR 14-519	T-20/3	SR M4X6DIN912	HW 3.0
C6 HAD	63.00	60.00	22.0	SR 14-519	T-20/3	SR M4X6DIN912	HW 3.0

For tools, see pages: HFAER/L-4 (551) • HFAER/L-5T, 6T (552) • HFAIR/L-4 (554) • HFAIR/L-DG (555) • HGAER/L-3 (551) • HGAIR/L-3 (554)

CAMFIX

C#-HAPR/L

Perpendicular Holders with CAMFIX Exchangeable Shanks for Internal Facing Adapters

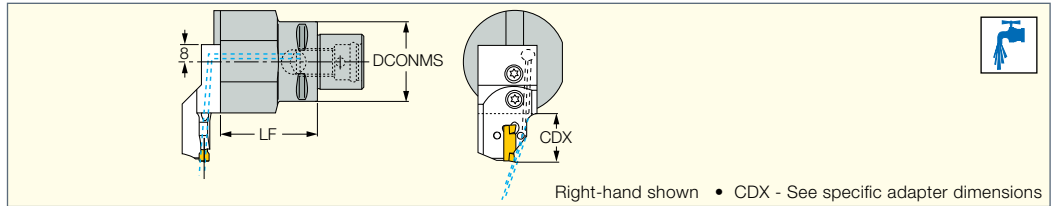

Right-hand shown • CDX - See specific adapter dimensions

Designation	DCONMS	LF		
C4 HAPR/L	40.00	50.00	SR 14-519	T-20/3
C6 HAPR/L	63.00	50.00	SR 14-519	T-20/3

For tools, see pages: HFAER/L-4 (551) • HFAER/L-5T, 6T (552) • HFAIR/L-4 (554) • HFAIR/L-DG (555) • HGAER/L-3 (551) • HGAIR/L-3 (554)

CAMFIX

EX C# (CAMFIX extension)

CAMFIX Extension Adapters

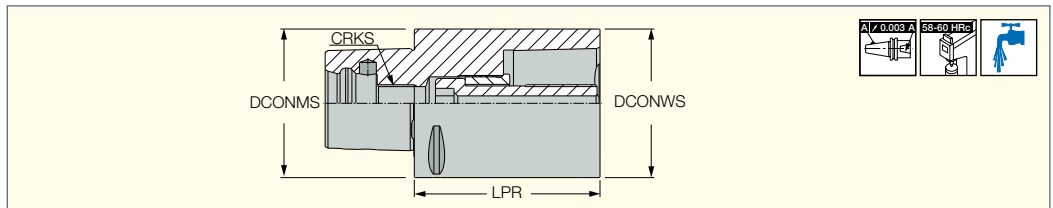

Designation	DCONMS	DCONWS	LPR	CRKS	
C3 EX C3X060	32.00	32.00	60.00	M12	0.40
C3 EX C3X080	32.00	32.00	80.00	M12	0.50
C4 EX C4X060	40.00	40.00	60.00	M14	0.50
C4 EX C4X080	40.00	40.00	80.00	M14	0.70
C5 EX C5X080	50.00	50.00	80.00	M16	1.13
C5 EX C5X100	50.00	50.00	100.00	M16	1.42
C6 EX C6X100	63.00	63.00	100.00	M20	2.23
C6 EX C6X140	63.00	63.00	140.00	M20	3.13
C8 EX C8X100	80.00	80.00	100.00	M20	3.65
C8 EX C8X125	80.00	80.00	125.00	M20	4.60

Spare Parts

Designation						
C3 EX C3X060	SR M12X50 C3	HW 7.0*	MT RING M18X15XC3		WRENCH COOL TUBE C3*	WRENCH C3 DRW NUT*
C3 EX C3X080	SR M12X50 C3	HW 7.0*	MT RING M18X15XC3		WRENCH COOL TUBE C3*	WRENCH C3 DRW NUT*
C4 EX C4X060	SR M14X58 C4	HW 8.0*	MT RING M22X17XC4	COOLING TUBE C4*	WRENCH COOL TUBE C4*	WRENCH C4 DRW NUT*
C4 EX C4X080	SR M14X58 C4	HW 8.0*	MT RING M22X17XC4	COOLING TUBE C4*	WRENCH COOL TUBE C4*	WRENCH C4 DRW NUT*
C5 EX C5X080	SR M16X70 C5	HW 10.0*	MT RING M25X20XC5	COOLING TUBE C5*	WRENCH COOL TUBE C5*	WRENCH C5 DRW NUT*
C5 EX C5X100	SR M16X70 C5	HW 10.0*	MT RING M25X20XC5	COOLING TUBE C5*	WRENCH COOL TUBE C5*	WRENCH C5 DRW NUT*
C6 EX C6X100	SR M20X87 C6/8	HW 14.0*	MT RING M30X24XC6/8	COOLING TUBE C6*	WRENCH COOL TUBE C6*	WRENCH C6-8 DRW NUT*
C6 EX C6X140	SR M20X87 C6/8	HW 14.0*	MT RING M30X24XC6/8	COOLING TUBE C6*	WRENCH COOL TUBE C6*	WRENCH C6-8 DRW NUT*
C8 EX C8X100	SR M20X87 C6/8	HW 14.0*	MT RING M30X24XC6/8	COOLING TUBE C8*	WRENCH COOL TUBE C8*	WRENCH C6-8 DRW NUT*
C8 EX C8X125	SR M20X87 C6/8	HW 14.0*	MT RING M30X24XC6/8	COOLING TUBE C8*	WRENCH COOL TUBE C8*	WRENCH C6-8 DRW NUT*

* Optional, should be ordered separately

CAMFIX

RE-C#

CAMFIX Reduction Adapters

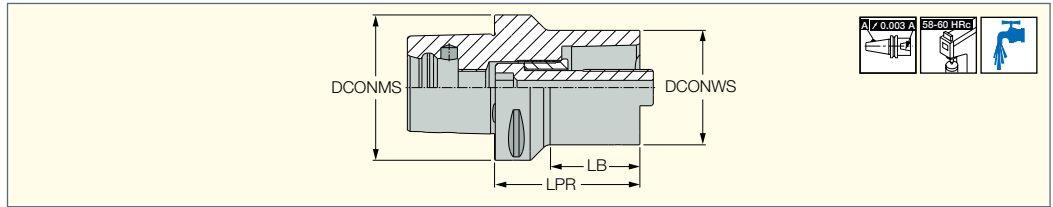

Designation	DCONMS	DCONWS	LPR	LB	kg
C4 RE C3X070	40.00	32.00	70.00	12.00	0.50
C6 RE C3X070	63.00	32.00	70.00	39.00	1.10
C6 RE C4X080	63.00	40.00	80.00	51.40	1.20
C6 RE C5X080	63.00	50.00	80.00	51.50	1.50
C8 RE C3X060	80.00	32.00	60.00	29.30	1.70
C8 RE C4X070	80.00	40.00	70.00	36.50	1.90
C8 RE C5X080	80.00	50.00	80.00	49.30	2.20
C8 RE C6X080	80.00	63.00	80.00	53.10	2.50
C8 RE C6X120	80.00	63.00	120.00	12.00	4.00

Spare Parts

Designation						
C4 RE C3X070	SR M12X50 C3	HW 7.0*	MT RING M18X15XC3	COOLING TUBE C4*	WRENCH COOL TUBE C4*	WRENCH C3 DRW NUT*
C6 RE C3X070	SR M12X50 C3	HW 7.0*	MT RING M18X15XC3	COOLING TUBE C6*	WRENCH COOL TUBE C6*	WRENCH C3 DRW NUT*
C6 RE C4X080	SR M14X58 C4	HW 8.0*	MT RING M22X17XC4	COOLING TUBE C6*	WRENCH COOL TUBE C6*	WRENCH C4 DRW NUT*
C6 RE C5X080	SR M16X70 C5	HW 10.0*	MT RING M25X20XC5	COOLING TUBE C6*	WRENCH COOL TUBE C6*	WRENCH C5 DRW NUT*
C8 RE C3X060	SR M12X50 C3	HW 7.0*	MT RING M18X15XC3	COOLING TUBE C8*	WRENCH COOL TUBE C8*	WRENCH C3 DRW NUT*
C8 RE C4X070	SR M14X58 C4	HW 8.0*	MT RING M22X17XC4	COOLING TUBE C8*	WRENCH COOL TUBE C8*	WRENCH C4 DRW NUT*
C8 RE C5X080	SR M16X70 C5	HW 10.0*	MT RING M25X20XC5	COOLING TUBE C8*	WRENCH COOL TUBE C8*	WRENCH C5 DRW NUT*
C8 RE C6X080	SR M20X87 C6/8	HW 14.0*	MT RING M30X24XC6/8	COOLING TUBE C8*	WRENCH COOL TUBE C8*	WRENCH C6-8 DRW NUT*
C8 RE C6X120	SR M20X87 C6/8	HW 14.0*	MT RING M30X24XC6/8	COOLING TUBE C8*	WRENCH COOL TUBE C8*	WRENCH C6-8 DRW NUT*

* Optional, should be ordered separately

HSK-T (ISO 12164-3 T Type and ICTM Standards)

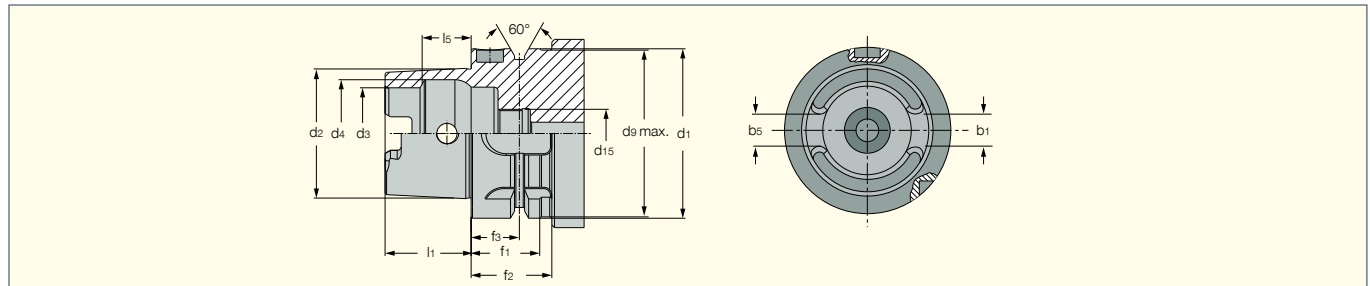

HSK-AWH	d1 h10	d2	d3 H10	d4 H11	d9 max	d15	l1-0.2	l5 Js10	b1 ±0.04	b2 ±0.035	f1 -0.1	f2 min	f3 ±0.1
63	63	48	34	40	62	M18X1	32	18.13	12.54	12.425	26	30	18
100	100	75	53	63	99	M24X1.5	50	28.56	20.02	19.91	29	34	20

HSK A vs HSK A WH Tolerance

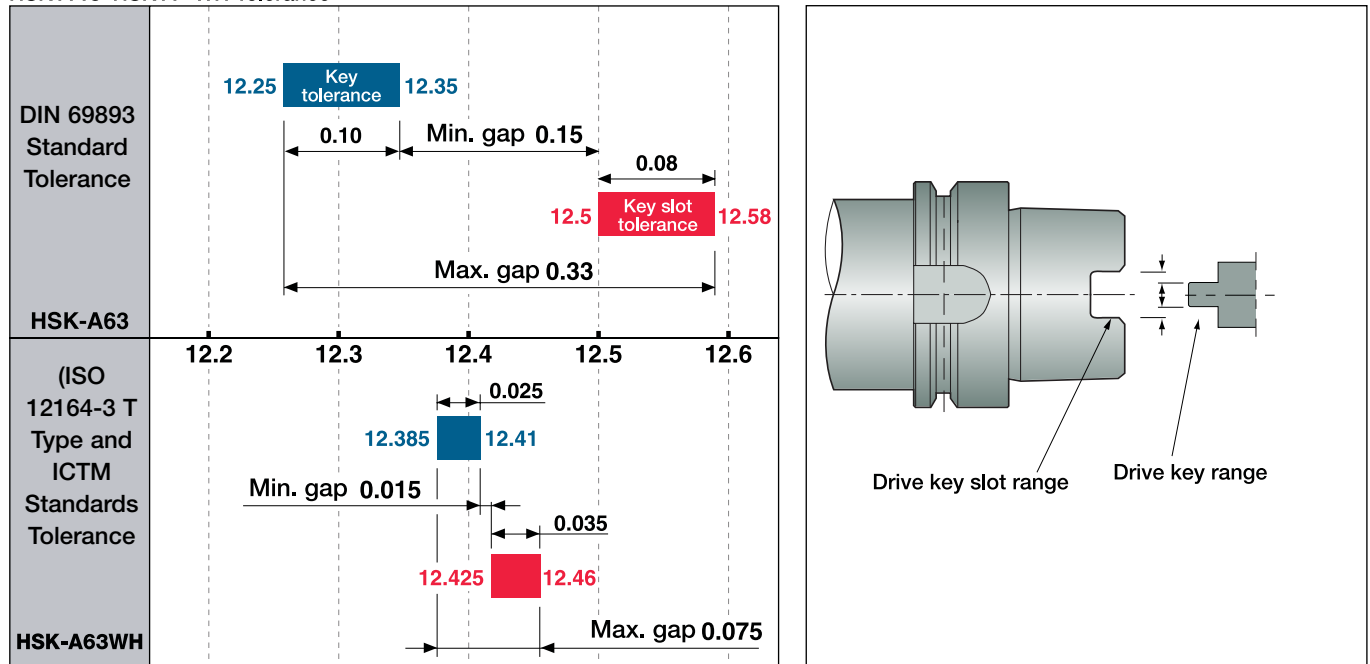

MODULAR-GRIP HSK

HSK A63WH-MAHDR-45

Holders with HSK Tapered Shanks for MODULAR-GRIP, Parting, Grooving and Facing Adapters

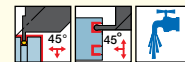
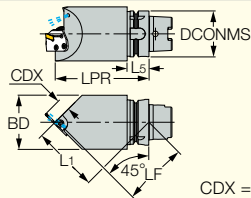

CDX = See specific adapter dimensions • Right-hand shown

Designation	DCONMS	LPR	L ₁	L ₅	LF	BD
HSK A63WH MAHDR 45	63.00	130.00	91.9	30.00	89.0	75.00

- A cooling tube must be used with all coolant through HSK spindles (should be ordered separately)
- Complies with ICTM standard (ISO 12164-3)
- For tools, see pages: CGPAD (265) • DGAD-B-D (436) • DGAD/HGAD (436) • HFPAD-3 (549) • HFPAD-4 (549) • HFPAD-5 (550) • HFPAD-6 (550) • HGPAD (251) • PCADR/L (300) • SCLCR-PAD (50) • SDJCR-PAD (54) • SVJCR-PAD (60) • SWAPR-PAD (66) • TGAD (455) • TGPAD (256) • TTADR/L-JHP (651)



Spare Parts

Designation							
HSK A63WH MAHDR 45	SR M5-04451	T-20/5	SR 14-519 ^(a)	SR M6X20-XT	HW 5.0	SR M6X6DIN551 14H/22H ^(b)	SATZ-M8X1-M3

^(a) For DGAD, HGAD and PCADR/L adapters; supplied in the attached plastic bag

^(b) Used to prevent chips from entering the upper locking screw hole when it is not used for the adaptation; supplied in the attached plastic bag

MODULAR-GRIP HSK

HSK A63WH-MAHDOR

Holders with HSK Exchangeable Shanks for Parting, Grooving, Turning and Facing Adapters

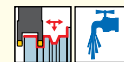
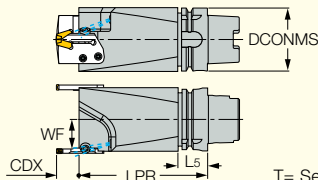

T= See specific adapter dimensions • Right-hand shown

Designation	DCONMS	WF	LPR	L ₅							
HSK A63WH MAHDOR	63.00	29.0	130.00	30.00	SR M5-04451	T-20/5	SR 14-519 ^(a)	SR M6X20-XT ^(b)	HW 5.0	SR M6X6DIN551 14H/22H ^(c)	EZ 125

- A cooling tube must be used with all coolant through HSK spindles (should be ordered separately)
- Complies with ICTM standard (ISO 12164-3)

(a) For DGAD, HGAD and PCADR/L adapters; supplied in the attached plastic bag

(b) For CGPAD, HGPAD, TGPAD and HFPAD adapters; supplied with the tools

(c) Used to prevent chips from entering the upper locking screw hole when it is not used for the adaptation; supplied in the attached plastic bag

- For tools, see pages: CGPAD (265) • DGAD-B-D (436) • DGAD/HGAD (436) • HFPAD-3 (549) • HFPAD-4 (549) • HFPAD-5 (550) • HFPAD-6 (550) • HGPAD (251) • PCADR/L (300) • SCLCR-PAD (50) • SDJCR-PAD (54) • SVJCR-PAD (60) • SWAPR-PAD (66) • TGAD (455) • TGPAD (256) • TTADR/L-JHP (651)

MODULARGRIP HSK

HSK A63WH-MAHUR/L

Holders with HSK-T Shanks for 10° Mounting on Mill-Turn Machines for Parting, Grooving, Turning and Facing Adapters

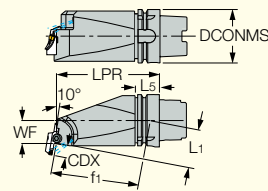

CDX = See specific adapter dimensions • Right-hand shown

Designation	DCONMS	f ₁	WF	LPR	L ₁	L ₅
HSK A63WH MAHUR/L 10	63.00	113.1	29.00	130.00	49.4	30.00

- A cooling tube must be used with all coolant through HSK spindles (should be ordered separately)
- Complies with ICTM standard (ISO 12164-3)
- For tools, see pages: CGPAD (265) • DGAD-B-D (436) • DGAD/HGAD (436) • HFPAD-3 (549) • HFPAD-4 (549) • HFPAD-5 (550) • HFPAD-6 (550) • HGPAD (251) • PCADR/L (300) • SCLCR-PAD (50) • SDJCR-PAD (54) • SVJCR-PAD (60) • SWAPR-PAD (66) • TGAD (455) • TGPAD (256) • TTADR/L-JHP (651)

Spare Parts

Designation							
HSK A63WH MAHUR/L 10	SR M5-04451	T-20/5	SR 14-519(a)	SR M6X20-XT(b)	HW 5.0	SR M6X6DIN551 14H/22H(c)	EZ 125

(a) For DGAD, HGAD and PCADR/L adapters; supplied in the attached plastic bag

(b) For CGPAD, HGPAD, TGPAD and HFPAD adapters; supplied with the tools

(c) Used to prevent chips from entering the upper locking screw hole when it is not used for the adaptation; supplied in the attached plastic bag

TOOL BLOCKS HSK

HSK A-WH-TBK-R/L

Blocks with HSK Exchangeable Tapered Shanks for Parting and Grooving Blades

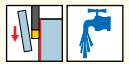
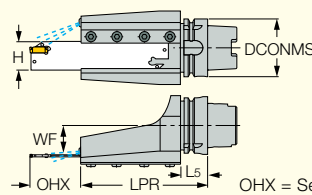

OHX = See specific blade dimensions • Right-hand shown

Designation	DCONMS	LPR	L ₅	WF	H ⁽¹⁾				
HSK A63WH TBK 32R/L	63.00	138.00	30.00	32.0	32.0	BK 32-9 WEDG	SR M6X16 DIN912	HW 5.0	EZ 125
HSK A100WH-TBK-32L	100.00	150.00	34.00	50.0	32.0	BK 32-9 WEDG	SR M6X16 DIN912	HW 5.0	SATZ-M12X1-M6

- Complies with ICTM standard (ISO 12164-3)
- Not suitable for ATC for some Multi-Tasking Machines models, please consult your MTB
- A cooling tube must be used with all coolant through HSK spindles (should be ordered separately)

(1) Blade size H has to fit this dimension

- For tools, see pages: CGHN-DG (267) • CGHR/L-P8DG (267) • DGFH (252) • DGFHR/L (426) • DGFHR/L-B-D..(R/L) (428) • HFFH (546) • HGFB (251) • PCHBR/L (302) • SGFH-N () • TGFH/R/L (318) • TGFHR/L (452) • TNFFH-IQ (566)

EXCHANGEABLEHEADS IM (ISO 26622-1 and Mazak XMZ Standards)

IM ISO 26622-1 Standard

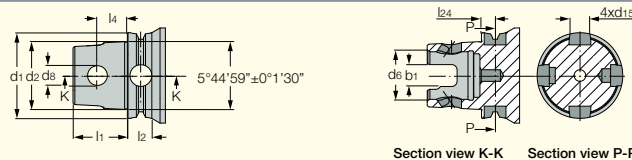

Section view K-K Section view P-P

IM UT	d ₁ -0.1	d ₂ ±0.0075	d ₆	d ₈	d ₁₅ H ₁₁	l ₁ -0.1	l ₂ min	l ₄	l ₂₄	b ₁
32	32	23.9975	17.65 +0.1	7.5	-	20	10	10.8	-	8.9
40	40	29.9975	21 +0.1	9.5	9	25	12	13.6	5.95	10
50	50	39.9975	28.2 +0.15	12.5	12	32	18	17.2	8.95	14
63	63	49.9975	35.2 +0.15	14.5	16	40	20	22.4	9.95	16
80	80	63.9975	48 +0.15	18.5	16	45	22	24.9	10.95	20

ISO 26622-1 XMZ

ISCARGRIP

IM-TBU

Blocks with an ISO 26622-1(*) Tapered Shank for Parting and Grooving Blades

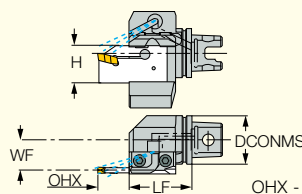

OHX - See specific blade dimensions • Right-hand shown

Designation	DCONMS	H	LF	WF						
IM40 TBU-32R	40.00	32.0	51.00	23.0	BKU 176 307	SR M6X25 DIN912	HW 5.0	SR M6X6 DIN913	EZP 5	EZ 125
IM50 TBU-32R/L	50.00	32.0	61.00	30.0	BKU 176 307	SR M6X25 DIN912	HW 5.0	SR M6X6 DIN913	EZP 5	EZ 125
IM63 TBU-32L	63.00	32.0	63.00	38.0	BKU 176 307	SR M6X25 DIN912	HW 5.0	SR M6X6 DIN913	EZP 5	EZ 125

(*) Tools with orientation holes in the flange groove can be supplied on request

- For tools, see pages: CGHN-S (266) • TGHN-S (257)

MODULARGRIP

ISO 26622-1 XMZ

IM-MAHD

Holders with an ISO 26622-1(*)
Tapered Shank for Parting,
Grooving, Turning and Facing
Adapters

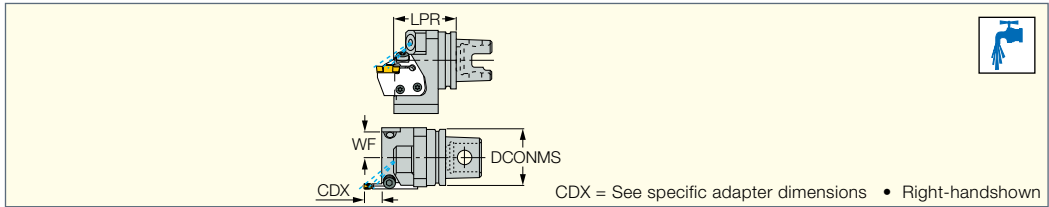

CDX = See specific adapter dimensions • Right-hand shown

Designation	DCONMS	LPR	WF
IM40 MAHD	40.00	43.00	18.0
IM50 MAHD	50.00	47.00	23.0
IM63 MAHD	63.00	52.00	29.0

• (*) Tools with orientation holes in the flange groove can be supplied on request

For tools, see pages: CGPAD (265) • DGAD-B-D (436) • DGAD/HGAD (436) • HFPAD-3 (549) • HFPAD-4 (549) • HFPAD-5 (550) • HFPAD-6 (550) • HGPAD (251) • PCADR/L (300) • SCLCR-PAD (50) • SDJCR-PAD (54) • SVJCR-PAD (60) • SWAPR-PAD (66) • TGAD (455) • TGPAD (256) • TTADR/L-JHP (651)

Spare Parts

Designation									
IM-MAHD	SR M5-04451	T-20/5	SR 14-519 ^(a)	SR M6X20-XT ^(b)	HW 5.0	SR M6X6DIN551 14H/22H ^(c)	SR 76-1022	EZA 125	EZ 125

^(a) For DGAD, HGAD and PCADR/L adapters; supplied in the attached plastic bag

^(b) For CGPAD, HGPAD, TGPAD and HFPAD adapters; supplied with the tools

^(c) Used to prevent chips from entering the upper locking screw hole when it is not used for the adaptation; supplied in the attached plastic bag

MODULARGRIP

ISO 26622-1 XMZ

IM-MAHPD

Perpendicular Holders with
an ISO 26622-1(*) Tapered
Shank for Parting, Grooving,
Turning and Facing Adapters

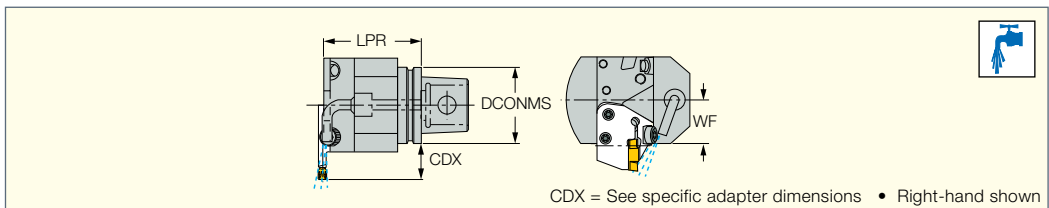

CDX = See specific adapter dimensions • Right-hand shown

Designation	DCONMS	LPR	WF
IM40 MAHPD	40.00	44.00	25.00
IM50 MAHPD	50.00	45.00	26.00
IM63 MAHPD	63.00	45.00	33.00

• (*) Tools with orientation holes in the flange groove can be supplied on request

For tools, see pages: CGPAD (265) • DGAD-B-D (436) • DGAD/HGAD (436) • HFPAD-3 (549) • HFPAD-4 (549) • HFPAD-5 (550) • HFPAD-6 (550) • HGPAD (251) • PCADR/L (300) • SCLCR-PAD (50) • SDJCR-PAD (54) • SVJCR-PAD (60) • SWAPR-PAD (66) • TGAD (455) • TGPAD (256) • TTADR/L-JHP (651)

Spare Parts

Designation								
IM-MAHPD	SR M5-04451	T-20/5	SR 14-519 ^(a)	SR M6X20-XT ^(b)	HW 5.0	SR M6X6DIN551 14H/22H ^(c)	EZP 5	EZ 125

^(a) For DGAD, HGAD and PCADR/L adapters; supplied in the attached plastic bag

^(b) For CGPAD, HGPAD, TGPAD and HFPAD adapters; supplied with the tools

^(c) Used to prevent chips from entering the upper locking screw hole when it is not used for the adaptation; supplied in the attached plastic bag

ISO 26622-1 XMZ

ISCARGRIP

IM-GHAD-8

Holders with an ISO 26622-1(*)
Tapered Shank for Grooving,
Turning and Facing Adapters

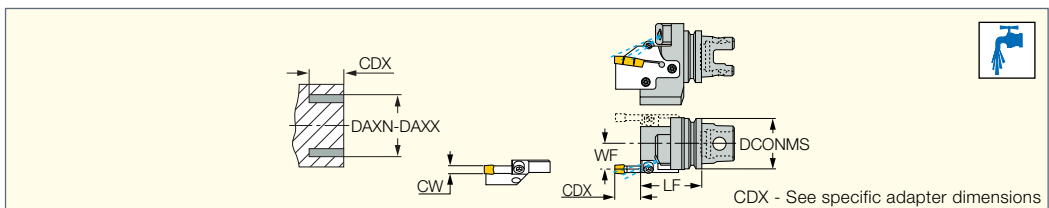

CDX - See specific adapter dimensions

Designation	DCONMS	CW	LF	WF	DAXN ⁽¹⁾	DAXX ⁽²⁾	CDX
IM50 GHAD-8	50.00	8.00	60.00	26.00	80.0	510.0	25.00
IM63 GHAD-8	63.00	8.00	65.00	32.50	80.0	510.0	25.00

• (*) Tools with orientation holes in the flange groove can be supplied on request

⁽¹⁾ Minimum axial grooving diameter

⁽²⁾ Maximum axial grooving diameter

For tools, see pages: GADR/L-8 (269) • GAFG-R/L-8 (562) • PCADR/L 34N-RE (301)

Spare Parts

Designation							
IM-GHAD-8	SR 14-519	T-20/5	SR M6X25 DIN912	HW 5.0	SR 76-1022	EZA 125	EZ 125

ISO 26622-1 XMZ

ISCAR GRIP

IM-GHAPR/L-8

Perpendicular Holders with an ISO 26622-1(*) Tapered Shank for Grooving, Turning and Facing Adapters

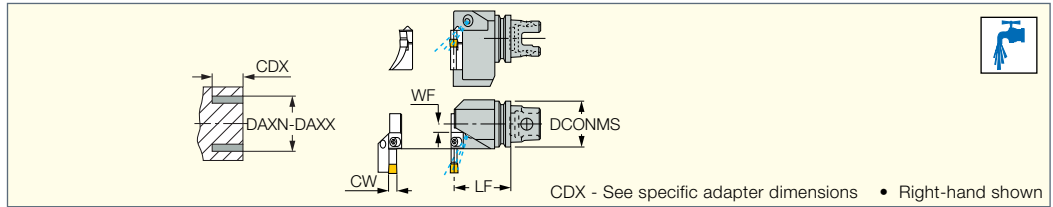

Designation	DCONMS	LF	WF	CW	DAXN ⁽¹⁾	DAXX ⁽²⁾	CDX					
IM50 GHAPR/L-8	50.00	60.00	26.00	8.00	80.0	510.0	25.00	SR 14-519	T-20/5	SR M6X25 DIN912	HW 5.0	EZ 125
IM63 GHAPL-8	63.00	75.00	33.00	8.00	80.0	510.0	25.00	SR 14-519	T-20/5	SR M6X25 DIN912	HW 5.0	EZ 125

• (*) Tools with orientation holes in the flange groove can be supplied on request

⁽¹⁾ Minimum axial grooving diameter

⁽²⁾ Maximum axial grooving diameter

For tools, see pages: GADR/L-8 (269) • GAFG-R/L-8 (562) • PCADR/L 34N-RE (301)

ISO 26622-1 XMZ

ISCAR GRIP

IM-HAD

Holders with an ISO 26622-1(*) Tapered Shank for Internal Facing Adapters

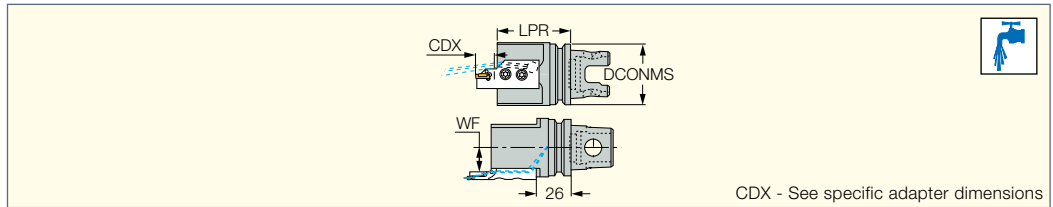

Designation	DCONMS	LPR	WF				
IM40 HAD	40.00	60.00	18.0	SR 14-519	T-20/3	HW 3.0	SR M4X6DIN912
IM50 HAD	50.00	60.00	18.0	SR 14-519	T-20/3	HW 3.0	SR M4X6DIN912

• (*) Tools with orientation holes in the flange groove can be supplied on request

For tools, see pages: HFAER/L-4 (551) • HFAER/L-5T, 6T (552) • HFAIR/L-4 (554) • HFAIR/L-DG (555) • HGAER/L-3 (551) • HGAIR/L-3 (554)

ISO 26622-1 XMZ

ISCAR GRIP

IM-HAPR/L

Perpendicular Holders with an ISO 26622-1(*) Tapered Shank for Internal Facing Adapters

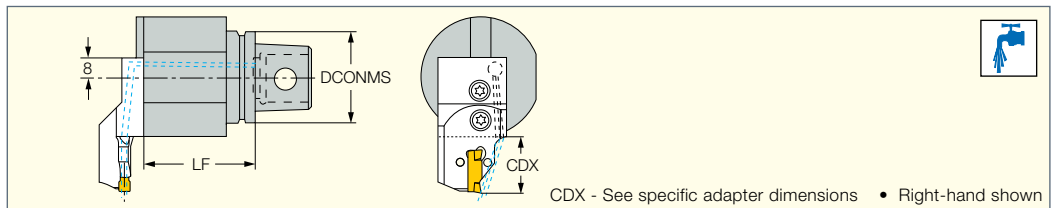

Designation	DCONMS	LF		
IM40 HAPR/L	40.00	50.00	SR 14-519	T-20/3
IM50 HAPR/L	50.00	50.00	SR 14-519	T-20/3

• (*) Tools with orientation holes in the flange groove can be supplied on request

For tools, see pages: HFAER/L-4 (551) • HFAER/L-5T, 6T (552) • HFAIR/L-4 (554) • HFAIR/L-DG (555) • HGAER/L-3 (551) • HGAIR/L-3 (554)